

1 – MATERIAL DE DESENHO E SEU USO

Material de desenho	1 - 1
Lápis	1 - 3
Esquadro	1 - 4
Compasso	1 - 5

2 – DESENHO GEOMÉTRICO

Construções fundamentais	2 - 1
Uso da curva francesa	2 - 6
Cônicas	2 - 7
Hélices	2 - 8
Cíclicas	2 - 9
Concóides ou conchóides	2-10

3 – PROJEÇÕES ORTOGONAIS

Projeção ortogonal (norma européia)	3 - 1
Exemplos	3 - 2
Representação em duas vistas	3 - 4
Representação em três vistas	3 - 5
Vistas necessárias e suficientes	3 - 6
Projeção ortogonal de peças inclinadas	3 - 7
Exemplo	3 - 8
Exemplo	3 - 9
Projeção ortogonal (norma norte-americana)	3-10
Metódos de projeção ortogonal	3-11
Comparação	3-12

índice

CVRD

SUFET

ARQUIVO TÉCNICO

4 — PERSPECTIVA

Perspectiva exata	4 - 1
Perspectivas aproximadas	4 - 2
Perspectiva de circunferências	4 - 3
Perspectiva de peças irregulares	4 - 6
Escolha da perspectiva	4 - 7
Escolha da posição	4 - 8
Seqüência do traçado	4 - 9
Perspectiva cavaleira	4-12
Perspectiva Isométrica	4-13
Perspectiva bimétrica	4-14
Exemplos	4-15
Perspectiva sombreada	4-16
Croquis em perspectiva Isométrica	4-18
Croquis em perspectiva cavaleira	4-19

5 — NORMAS E CONVENÇÕES

Formato de papel	5 - 1
Dobramento da folha	5 - 2
Letras e algarismos	5 - 2
Linhas	5 - 3
Escala	5 - 3
Vistas	5 - 4
Hachuras	5 - 6
Cortes e secções	5 - 7
Rupturas	5-10
Representações simplificadas e convencionais	5-10

Sinais	5-13
Cotas	5-13
Recomendações e conselhos	5-21
Tipos de reforços	5-21
Alfabeto grego	5-27

6 — ELEMENTOS DE MÁQUINAS

Glossário	6 - 1
Classificação dos desenhos técnicos	6 - 2
Seqüência do traçado de concordâncias	6 - 3
Seqüência do traçado de desenho a lápis	6 - 6
Seqüência do traçado de desenho a tinta	6 - 7
Exemplos	6 - 8
Tipos de roscas	6-15
Indicação das roscas	6-16
Traçado de roscas	6-17
Seqüência do traçado de roscas	6-18
Aplicação de roscas	6-19
Porcas e parafusos	6-20
Proporções dos parafusos	6-21
Tipos de porcas	6-22
Arruelas e dispositivos de segurança	6-23
Exemplos de aplicação	6-24
Parafusos e porcas especiais	6-26
Símbolos de parafusos	6-27
Indicação do acabamento e trabalho superficial	6-28
Conicidade e inclinação	6-29
Pinos e contra-pinos	6-31

Chavetas e linguetas	6-33	Juntas e uniões	6-66
Uniões forçadas (efeito de cunha)	6-34	Eixo cardan	6-68
Eixos ranhurados	6-36	Flanges	6-69
Rebitos	6-37	Engraxadeiras e marcadores de óleo	6-70
Aplicação de rebites	6-38	Molas	6-71
Rebites especiais	6-39	Tolerâncias e ajustes	6-72
Rebitagem de caldeiraria	6-40	Tipos de rolamentos	6-74
Estruturas rebitadas	6-41	Fixação e vedação de rolamentos	6-76
Símbolos de rebites	6-42	Aplicação de rolamentos	6-77
Símbolos de soldas (DIN 1911 e 1912)	6-43	Engrenagens cilíndricas de dentes retos	6-78
Solda a arco elétrico ou gás (norma americana)	6-45	Cálculos	6-79
Normas - Especificações dos Cordões de solda	6-46	Engrenagens cilíndricas de dentes retos (Sistema Pitch)	6-80
Exemplo de solda a arco	6-48	Cálculos	6-81
Solda com resistência elétrica (norma americana)	6-49	Engrenagem e cremalheira	6-82
Exemplos de solda com resistência	6-50	Cálculos	6-83
Comparação	6-51	Engrenagens cilíndricas de dentes retos	6-84
Exemplos de aplicação e solução	6-52	Cálculos	6-85
Polias	6-53	Engrenagens cilíndricas de dentes helicoidais	6-86
Esticadores de correia	6-55	Cálculos	6-87
Correntes	6-56	Engrenagens cônicas - seqüência do traçado	6-88
Rodas para corrente	6-57	Engrenagens cônicas a 90°	6-89
Esticadores de corrente	6-58	Cálculos	6-90
Gancho forjado	6-59	Engrenagens cônicas a 90° (Sistemas Pitch)	6-91
Gancho forjado duplo	6-60	Cálculos	6-92
Catracas	6-61	Engrenagens cônicas a 75°	6-93
Cames	6-62	Cálculos	6-94
Alavancas de comando	6-63	Engrenagens cônicas a 120°	6-95
Volantes e manivelas	6-64	Cálculos	6-96
Dispositivos de fixação	6-65	Coroa e rosca sem-fim	6-97

Cálculos	6-98
Engrenagens helicoidais de eixos ortogonais	6-99
Cálculos	6-100
Engrenagens helicoidais de eixos reversos	6-101
Seqüência do traçado	6-102
Cálculos	6-103
Mudança de marcha	6-104
Odontógrafo de GRANT	6-105
Engrenamentos a ciclóides e evolventes	6-106

7 – CONJUNTOS E DETALHES

Dispositivo de furar anéis	7 - 1
Torninho de mecânico	7 - 2
Torninho paralelo	7 - 3
Grampo	7 - 5
Grampo de ação rápida	7 - 6
Extrator	7 - 7
Extrator	7 - 8
Macaco	7 - 9
Alavanca de comando	7-10
Chave de grifo	7-11
Chave roquete	7-13
Morsa de bancada	7-15
Morsa para canos	7-18
Furador	7-22
Tesourão de bancada	7-24
Furadeira manual	7-26
Válvula de segurança	7-29
Bombinha de óleo	7-30
Inflador	7-32
Compressor de palheta	7-33

Moto redutor a ar comprimido	7-35
Macaco hidráulico	7-37
Macaco	7-40
Bomba de água	7-41
Pistão	7-44
Pistão	7-45
Biela	7-46
Biela	7-48
Virabrequim	7-50
Virabrequim	7-51
Tucho para válvula	7-52
Polia variável	7-53
Esticador de correia	7-54
Variador de velocidade	7-55
Variador de velocidade	7-57
Tipos de variadores de velocidade	7-58
Mancal de rolamento	7-59
Rodízio giratório	7-62
Contra-ponta giratória	7-65
Gancho	7-67
Gancho com trava	7-69
Máquina de rebitar	7-70
Estrutura metálica	7-72
Janelas de correr – esquerda de ferro	7-73
Janela de correr – detalhes	7-74
Janela guilhotina	7-76
Janela basculante	7-77
Guindaste giratório de parede	7-78
Sarilho para 250 kg	7-79

Elevador Transportador	7-81
Transportador aéreo	7-86
Trole acionado por corrente	7-88
Trole elétrico	7-92
Ponte rolante acionada por corrente	7-93
Talha manual para 1500 kg	7-98
Transportador de correia	7-101
Transportador de caneca	7-103
Transportador helicoidal	7-107
Redutor do transportador helicoidal (relação 1:1,5)	7-110
Redutor de velocidade (relação 1:3,8)	7-113
Redutor de velocidade (relação 1:35,85)	7-116
Redutor de velocidade (relação 1:4,95)	7-119
Redutor de rosca sem-fim (relação 1:40)	7-122
Caixa de direção	7-125
Balancin	7-127
Prensa excêntrica	7-129
Prensa excêntrica de 20 t	7-130
Furadeira de coluna	7-131
Plana limadora	7-132
Pá de hélice de avião	7-133
Registro de gaveta	7-134
Instalações típicas de ar comprimido	7-136
Instalações de ar comprimido para uso industrial	7-137
Ar condicionado	7-138
Refrigeração	7-139
Instalações para refrigeração de salmoura	7-140
Instalações de água quente	7-141
Armazenagem e vaporização de gás liquefeito de petróleo	7-142

Distribuição de óleo de queima	7-143
Ferramenta de corte	7-144
Ferramenta de dobra	7-146
Ferramenta combinada de corte, furação e repuxo	7-148
Ferramenta combinada de corte, furação e dobra	7-149
Ferramenta progressiva de corte e repuxo	7-150
Ferramenta progressiva de corte e repuxo	7-151
Ferramentas de cunha	7-152
Ferramenta para furação radial	7-153
Ferramenta para furação e dobra lateral	7-153
Ferramentas de dobra com punção oscilante	7-154
Alimentador	7-155
Molde para plástico	7-156

8 — FUNILARIA E CALDEIRARIA

Chapas; Arremates, Emendas, Desenvolvidos	8-0
Prisma reto de secção retangular	8-1
Tronco de prisma reto de secção retangular	8-1
Prisma inclinado de base retangular	8-2
Cilíndro reto e tronco de cilindro reto	8-3
Pirâmide reta de base quadrada	8-4
Tronco de pirâmide reta de base quadrada	8-4
Tronco de pirâmide reta de base hexagonal	8-5
Tronco de pirâmide oblíqua de base retangular	8-6
Cone circular reto	8-7
Tronco de cone circular reto	8-7
Tronco de cone circular reto com base superior oblíqua	8-8
Tronco de cone circular reto com base inferior oblíqua	8-9

Cone circular reto seccionado pelo vértice	8-11	Intersecção ortogonal de dutos redondos	8-34
Tronco de cone circular oblíquo I	8-12	Intersecção oblíqua de dutos redondos com diâmetros diferentes	8-35
Tronco de cone circular oblíquo II	8-13	Intersecção oblíqua de dutos redondos com diâmetros iguais. .	8-36
Redução concêntrica de duto redondo para redondo	8-14	Bifurcação simétrica de dutos redondos	8-37
Redução excêntrica de duto redondo para redondo	8-15	Intersecção de três dutos redondos com diâmetros iguais	8-38
Transição de duto quadrado para redondo	8-16	Redução com bifurcação simétrica de dutos redondos	8-39
Transição com redução concêntrica de duto retangular para redondo	8-17	Intersecção perpendicular de um cone reto com um duto redondo	8-40
Transição com redução de duto redondo para quadrado com desvio paralelo	8-18	Intersecção paralela de um cone reto com um duto redondo ..	8-41
Transição angular, a 90° , de duto redondo para retangular ...	8-19	Intersecção oblíqua de um cone reto com um duto redondo ..	8-42
Transição com redução de duto redondo para redondo com desvio angular	8-20	Intersecção oblíqua de dois cones	8-43
Transição com redução de duto redondo para oval com desvio paralelo	8-21	Bifurcação simétrica com aumento	8-44
Fechamento esférico de duto redondo	8-22	Bifurcação simétrica com redução	8-45
Esfera	8-23	Bifurcação assimétrica com redução	8-46
Coifa	8-24	Curva a 45° de três setores	8-47
Recipiente de base elíptica	8-25	Cotovelo de 5 setores	8-48
Banheira	8-26	Redução cônica em cotovelo (5 partes)	8-49
Calha	8-27		
Desvio paralelo de dutos retangulares	8-28		
Desvio angular	8-29		
Moldura	8-30		
Intersecção perpendicular de dutos quadrados	8-31		
Intersecção perpendicular de dutos redondos com diâmetros iguais	8-32		
Intersecção perpendicular de dutos redondos com diâmetros diferentes	8-33		

desenhista de máquinas

ENGº IND. MEC. FRANCESCO PROVENZA – CREA Nº 11.838/D

Ex-Orientador Técnico dos Cursos Profissionais e do Ginásio Industrial "Pro-Tec", Superintendente de Projetos da General Motors do Brasil, Prof.Ass. da Fac. Eng. Ind. da PUCSP, Prof. Contr. da Univ. Mackenzie e Prof. Regente da Escola de Eng. Mauá.



*Todos os direitos adquiridos e reservados
a propriedade literária desta publicação pela*

Edição 46ª – completamente revisada, corrigida e AMPLIADA.

*Nenhuma parte deste livro poderá ser reproduzida sejam quais
forem os meios empregados (mimeografia, xerox, datilografia, gravação,
reprodução em disco ou em fita), sem a permissão por escrito da Editora.*



EDITORA F. PROVENZA

R. Condessa de S. Joaquim, 256 – CEP 01320 - S. Paulo - Brasil
Fone: 270-0844/270-0083

Impresso na Gráfica Angrese Ltda.

1991

2213

1º PREFÁCIO

PRONTUÁRIO DO PROJETISTA DE MÁQUINAS



● A experiência adquirida no exercício da minha profissão, no campo da Engenharia Industrial e no ensino do Desenho Mecânico e Projetos de Máquinas, aconselhou-me esta publicação que, sem pretensão alguma, quer ser um simples guia para os estudantes, um prontuário para os projetistas de máquinas e um auxílio para os professores, obrigados a gastar muito tempo e trabalho para a execução de desenhos mecânicos e compilação de tabelas. ● As numerosas publicações deste tipo, apesar de possuírem indiscutíveis merecimentos, apresentam frequentemente o inconveniente de serem muito amplas, razão pela qual o estudante acaba não coordenando e utilizando convenientemente tôdas as noções e informações nela contidas. ● Levando em consideração o grau de preparação dos estudantes, muitos dos quais iniciam os Cursos de Desenho de Máquinas sem possuir um mínimo de conhecimento de noções técnicas, achei de bom alvitre organizar êste prontuário de tabelas elementares de cálculo e de desenho. ● A característica básica desta publicação consiste na ilustração e exposição sinótica de normas e convenções para a fácil e imediata execução e interpretação de desenhos de máquinas; no resumo de fórmulas e relações para o cálculo rápido de elementos de máquinas e na colheita de características e dados técnicos de materiais para construções mecânicas em geral, de fácil aquisição no mercado brasileiro. ● Agradeço sinceramente a todos os colaboradores que me auxiliaram a organizar e realizar esta publicação. ● Se êste trabalho fôr aceito como de utilidade, sentir-me-ei imensamente satisfeito e recompensado. ● Francesco Provenza ●

São Paulo, janeiro de 1960.

1ª Edição

A handwritten signature in black ink, which appears to read "Francesco Provenza". The signature is written in a cursive style and is underlined.

A experiência, a pesquisa e a dedicação ao magistério nos conduziram a esta publicação que, inegavelmente representa mais um tributo para o ensino e o progresso industrial do Brasil.

Realizamos uma obra clara e objetiva expondo com figuras tudo o que as simples palavras não teriam ilustrado suficientemente.

Forneceremos ao estudante noções práticas, concisas e completas para uma fácil, rápida e exata leitura, interpretação ou execução do desenho de máquinas.

Propiciamos ao desenhista uma fonte de consultas para dirimir eventuais dúvidas e um compêndio de normas e convenções.

Facilitamos a tarefa dos professores, coletando trabalhos com características didático-profissionais.

Tornamos leve e agradável esta matéria que, como simples representação de elementos de máquinas, é bastante árida.

Agradecemos a todos aqueles que participaram na realização desta publicação, aos que apontarem as eventuais falhas e erros.

São Paulo, outubro de 1972.

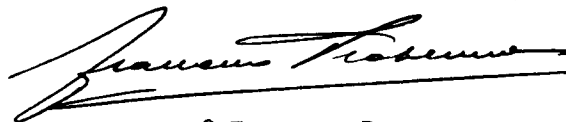

Eng^o Francesco Provenza

2^o prefácio

DESENHISTA

Registrado na Biblioteca Nacional sob o nº 22570

É proibido toda e qualquer reprodução sem a devida autorização da Editora.

A antiga publicação "Prontuário do Projetista de Máquinas" abrangia no seu conteúdo duas áreas: a de desenho mecânico e a de projetos de máquinas.

O progresso industrial e o avanço da tecnologia no Brasil obrigou-nos a rever, ampliar e adaptar às condições atuais a referida obra.

Desse trabalho resultaram dois livros:

"Desenhista de Máquinas", constituído de noções práticas, concisas e completas para uma fácil, rápida e exata leitura, interpretação ou execução do desenho de elementos de máquinas.

"Projetista de Máquinas", da qual o presente prefácio faz parte, constituído de tabelas, normas, fórmulas, relações, dados técnicos e características dos materiais para o cálculo rápido de elementos de máquinas.

Estas publicações visam os mesmos objetivos do antigo prontuário, quais sejam, facilitar a árdua tarefa dos alunos e dos mestres na coleta de informações técnico-didáticas e representar uma fonte de consulta para os profissionais.

Nossa preocupação foi a de apresentar um trabalho elementar de fácil consulta e não uma obra-prima reservada apenas aos entendidos.

Ficaremos satisfeitos se conseguirmos alcançar estes objetivos.

Agradecemos a todos aqueles que participaram da realização dessa publicação, aos que formularem críticas, aos que apontarem as eventuais falhas e erros.

São Paulo, março de 1976.

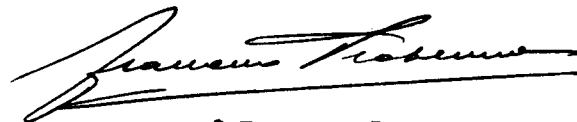

Eng^o Francesco Provenza

2º prefácio

PROJETISTA

Registrado na Biblioteca Nacional sob o nº 22569

É proibida toda e qualquer reprodução sem a devida autorização da Editora.



1 material de desenho e seu uso

material de desenho

lápiz

esquadro

compasso



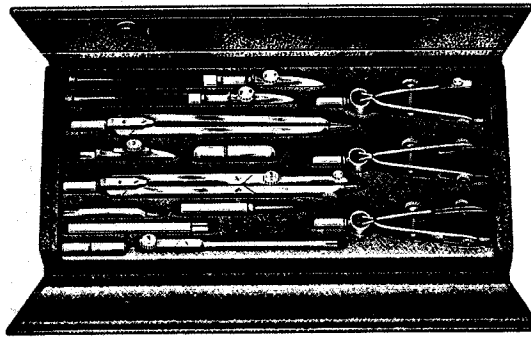

ESTOJO

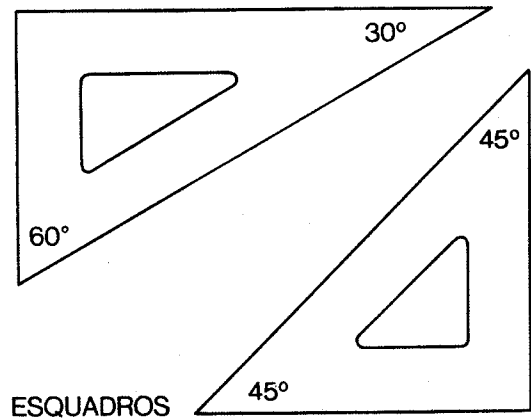

ESQUADROS

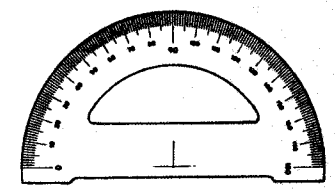

TRANSFERIDOR

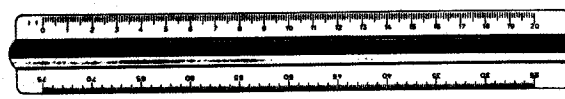

RÉGUA



CURVA FRANCESA

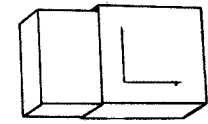

BORRACHA

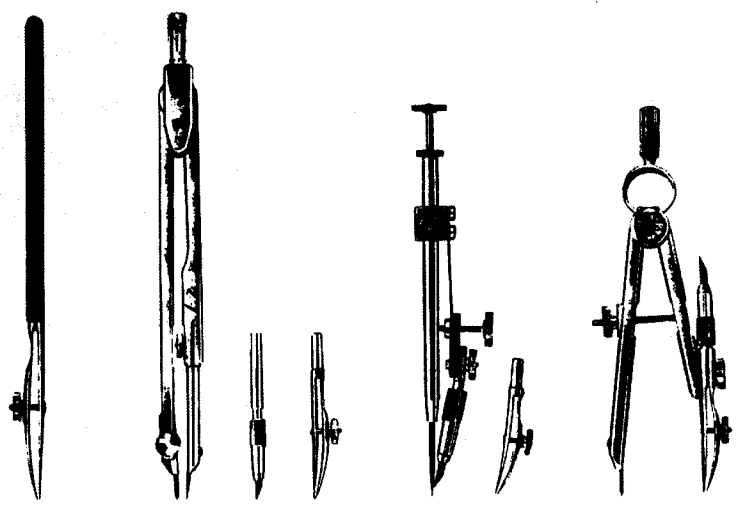

TIRA-LINHA

COMPASSOS

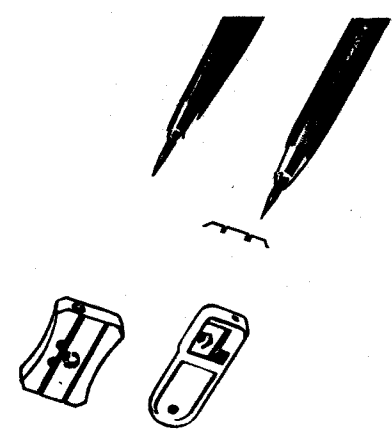

APONTADORES

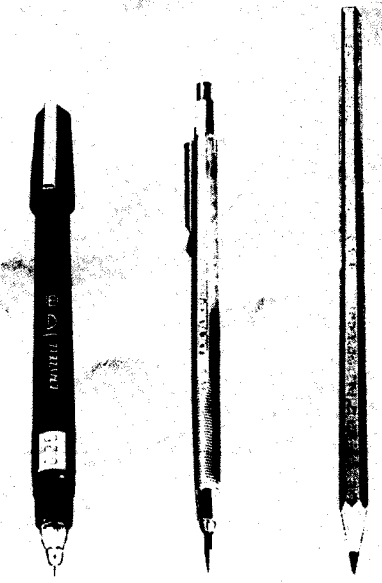

CANETA

LAPISEIRA

LAPIS

DUREZA DOS LÁPIS

GABARITO

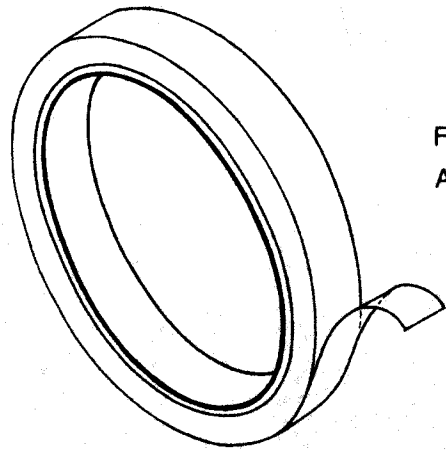
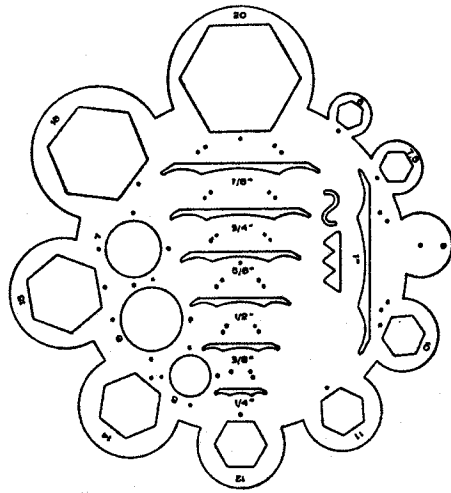

FITA
ADESIVA

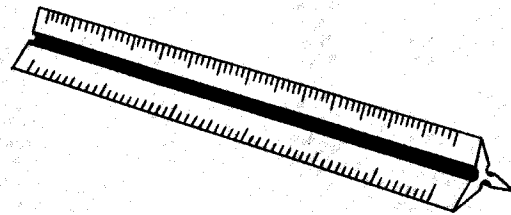

ESCALA



● Para uso preferencial



○ Para uso em segundo plano

● Para uso em terceiro plano



■ Denota a dureza de uso corrente

LÁPIS COMUM	QUALIDADE	OS MELHORES PARA DESENHO	PARA CROQUIS TÉCNICOS	PARA DESENHO DE PLANTAS	PARA TIRAR CÓPIAS À LUZ
	Macio especial, intensamente preto	7B			
	Extraordinariamente macio e preto	6B			
	Notavelmente macio e preto	5B			
	Bem macio e preto	4B			
1	Bem macio e bem preto	3B		●	
	Macio e bem preto	2B	○	○	
2	Macio e preto	B	●	○	●
	Semimacio e preto	HB	●	○	○
3	Semimacio	F	●	●	●
4	Duro	H	●	●	■
	Macio duro	2H	○	●	●
5	Bem duro	3H	○	●	●
	Notavelmente duro	4H		○	○
	Extraordinariamente duro	5H		○	
	Muitíssimo duro	6H		○	
	Dureza de pedra	7H			
	Dureza de aço	8H			
	Dureza de diamante	9H			

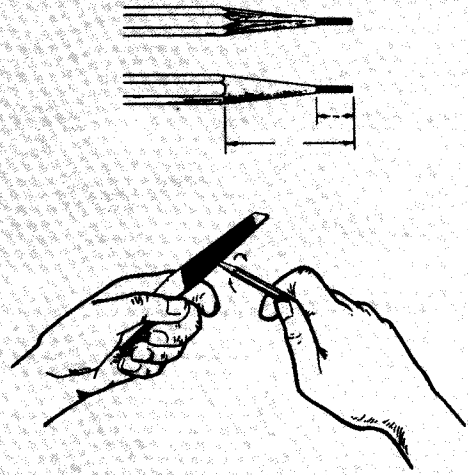

CUIDADOS COM A PONTA DO LAPIS

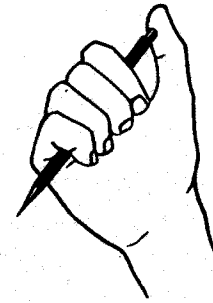
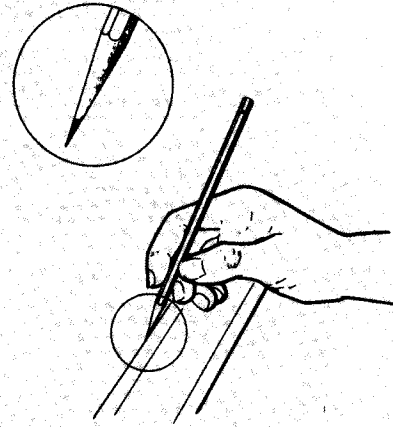

LAPISEIRA

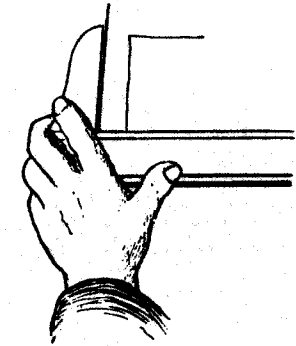

APOIANDO A RÉGUA T



PORTA MINAS

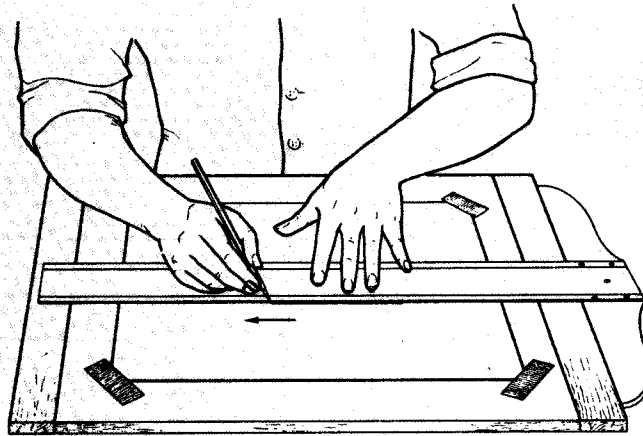

RETA HORIZONTAL

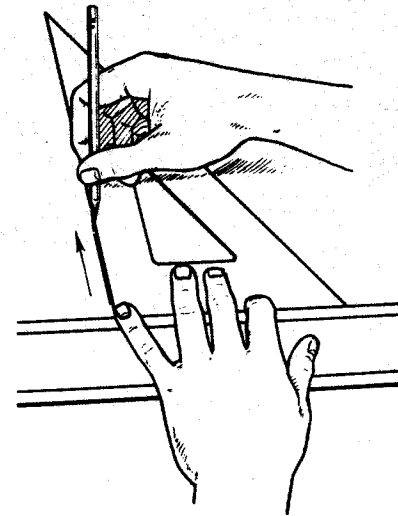

RETA VERTICAL

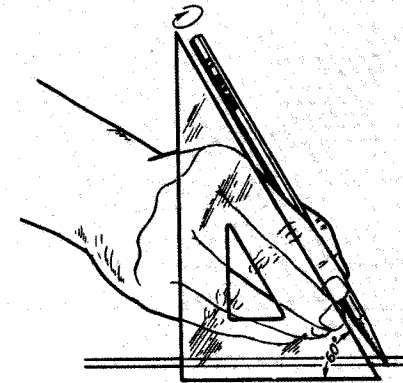

INCLINAÇÃO DO LAPIS

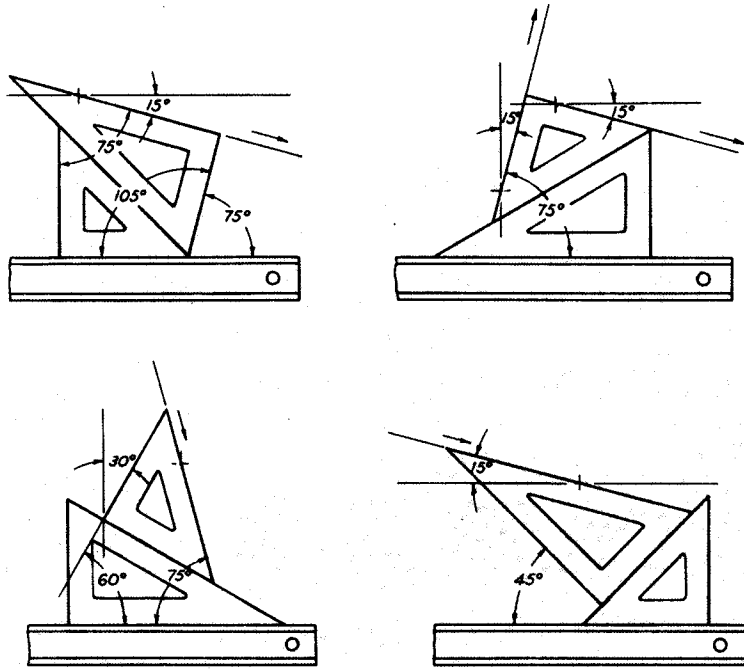

TECNÍGRAFO

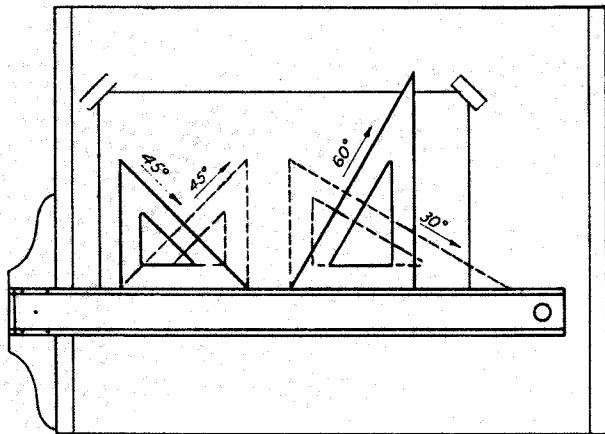
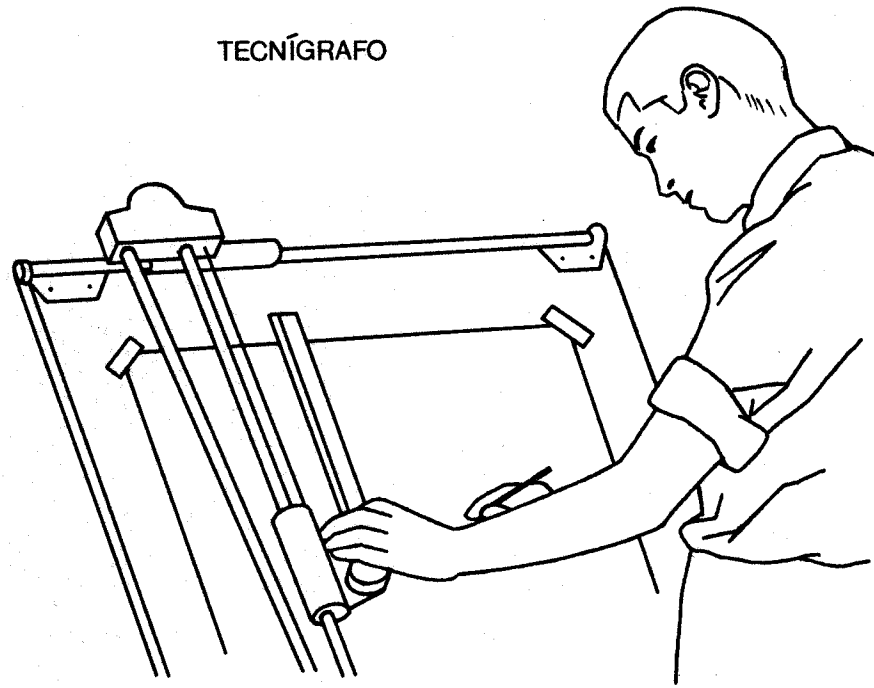

USO DO ESQUADRO

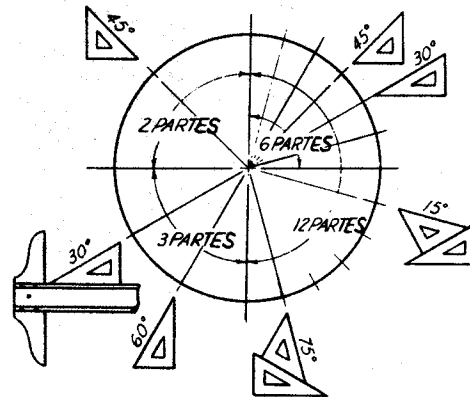

DIVISÃO DA CIRCUNFÊRENCIA

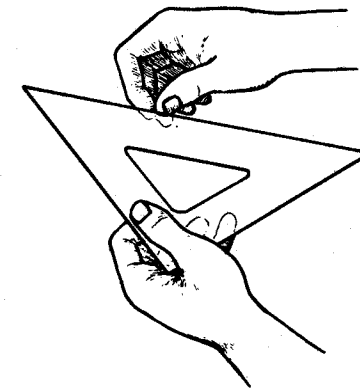

VERIFICAÇÃO DO ESQUADRO

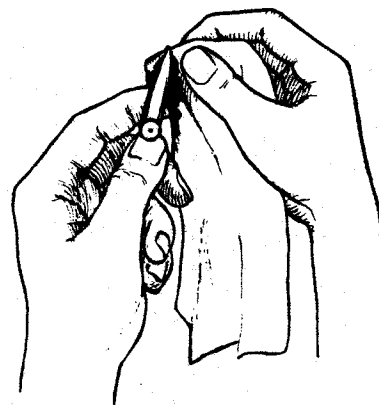
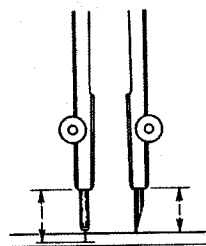
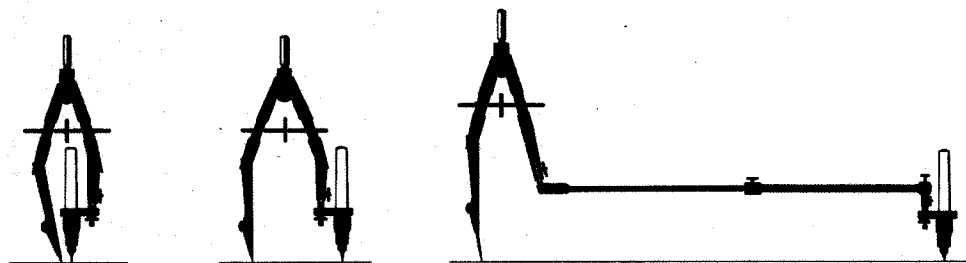

LIMPEZA DO TIRA-LINHA

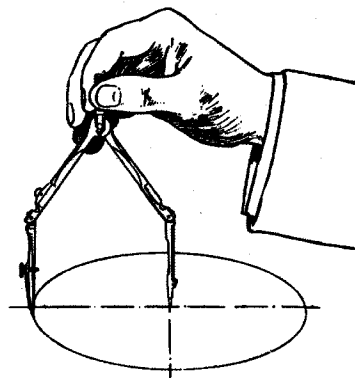

USO DO COMPASSO

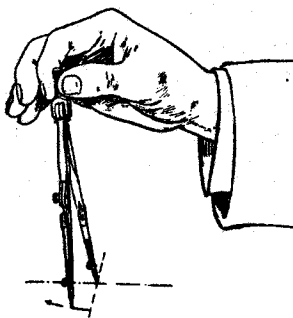

ESTOJO DE PENAS

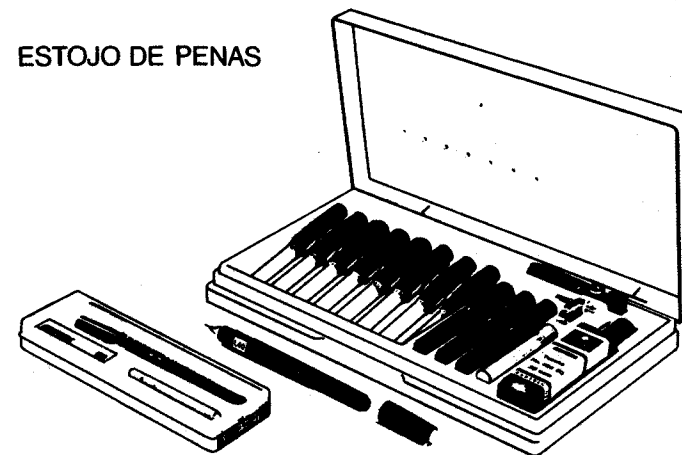

CONSELHOS E RECOMENDAÇÕES

- 1 - Trabalhar com prancheta e material de desenho limpos.
- 2 - Fixar a folha de desenho sobre a mesa com fita adesiva.
- 3 - Verificar os instrumentos antes de iniciar o trabalho.
- 4 - Desenhar sempre com a aresta superior da régua T ou similar.
- 5 - Usar a escala apenas para medir.
- 6 - Apontar o lapis ou lapiseira fora da mesa de desenho.
- 7 - Usar a borracha o mínimo indispensável eliminando as partículas com escova ou flanela.
- 8 - Não apoiar sobre o desenho objetos que possam sujá-lo.
- 9 - Não diluir a tinta nanquim com água.
- 10 - Não cortar o papel com lâmina utilizando a régua de desenho.



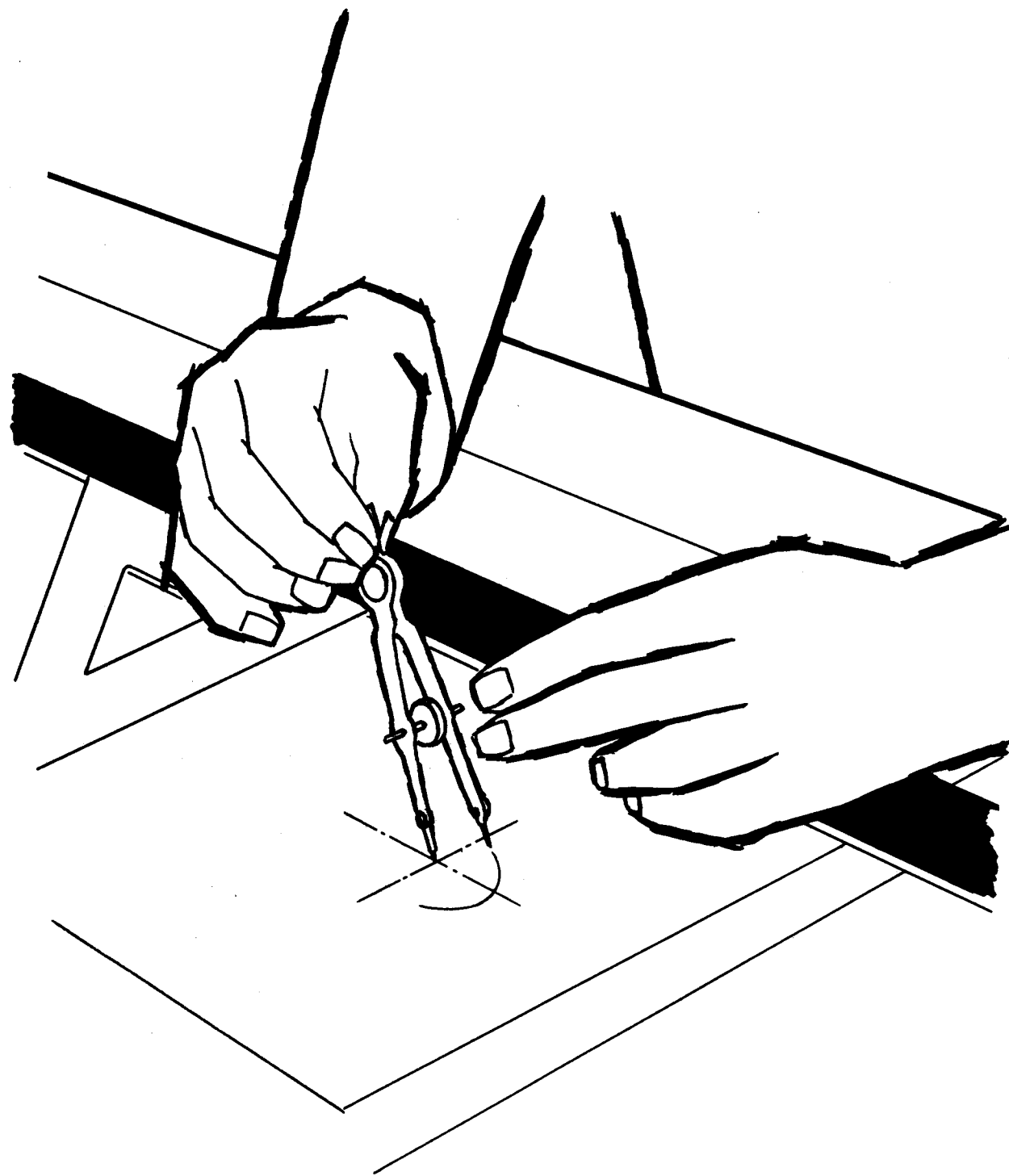

2

desenho geométrico

construções
fundamentais

cônicas

cíclicas

hélices



TRAÇAR O EIXO DO SEGMENTO AB

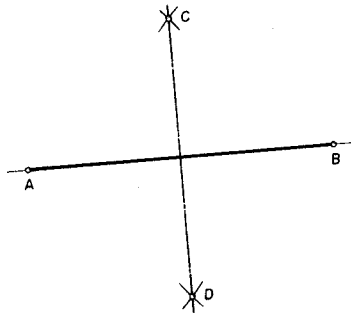

POR UM PONTO A À RETA r TRAÇAR A PERPENDICULAR.

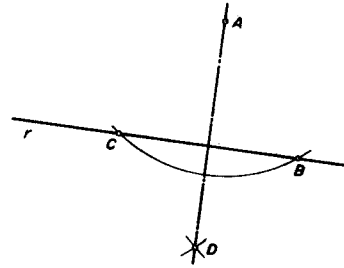

TRAÇAR A PERPENDICULAR À EXTREMIDADE DO SEGMENTO AB.

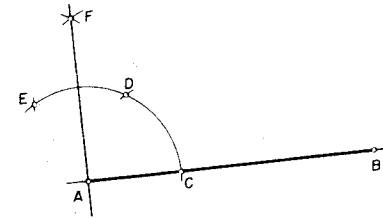

PELO PONTO A, TRAÇAR A PARALELA À RETA r .

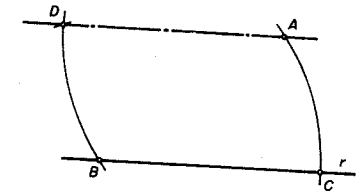

DIVIDIR O SEGMENTO AB EM QUALQUER NÚMERO DE PARTES IGUAIS. EXEMPLO: 6 PARTES.

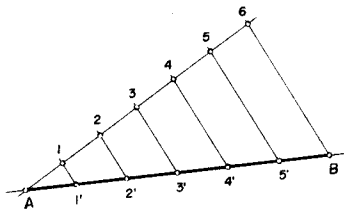

TRAÇAR A BISSETRIZ DO ÂNGULO \widehat{ABC} .

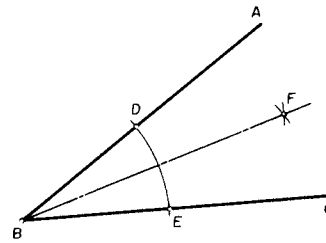

TRAÇAR A BISSETRIZ DE UM ÂNGULO QUALQUER, DESCONHECENDO-SE O VÉRTICE.

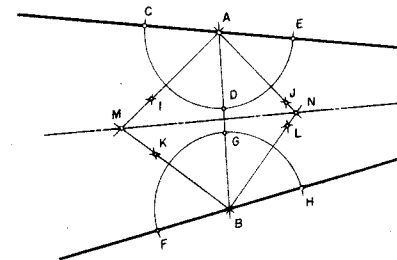

DIVIDIR O ÂNGULO RETO EM 3 PARTES IGUAIS.

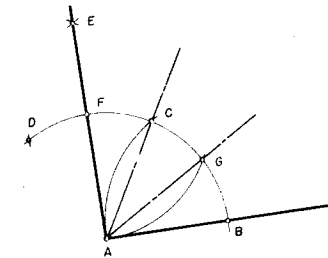

CONCORDAR O SEGMENTO AB COM O ARCO DE CIRCUNFERÊNCIA DE RAIO r .

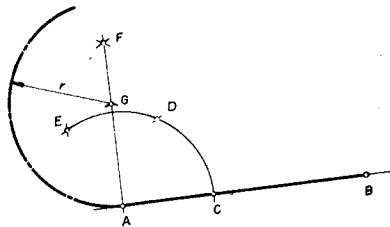

CONCORDAR O ARCO DE CIRCUNFERÊNCIA \widehat{AB} , COM UM OUTRO ARCO DE CIRCUNFERÊNCIA DE RAIO r .

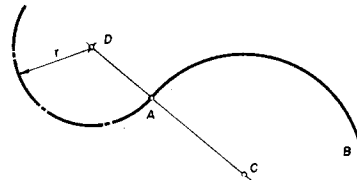

CONCORDAR O SEGMENTO AB, COM O ARCO DE CIRCUNFERÊNCIA QUE PASSA PELO PONTO C.

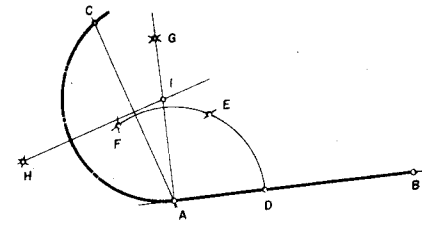

CONCORDAR O ARCO DE CIRCUNFERÊNCIA \widehat{AB} , COM UM OUTRO ARCO DE CIRCUNFERÊNCIA QUE PASSA PELO PONTO C.

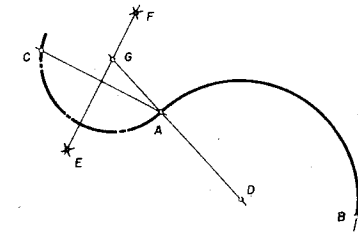

CONCORDAR A RETA r , PARALELA AO SEGMENTO AB, COM UM ARCO DE CIRCUNFERÊNCIA.

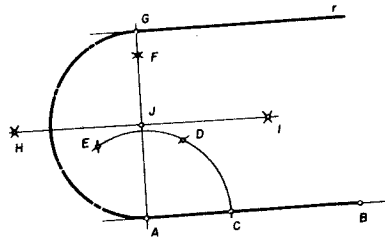

CONCORDAR AS RETAS t e s CONVERGENTES NO PONTO A COM UM ARCO DE CIRCUNFERÊNCIA DE RAIO r .

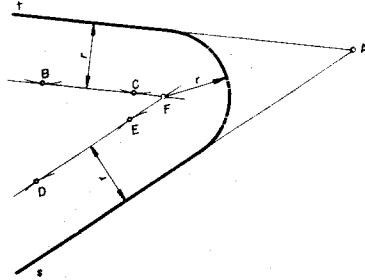

CONCORDAR A RETA t E O ARCO DE CIRCUNFERÊNCIA DE CENTRO O, COM UM OUTRO ARCO DE CIRCUNFERÊNCIA DE RAIO r .

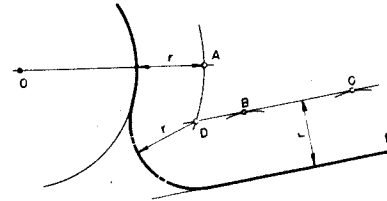

CONCORDAR OS ARCOS DE CIRCUNFERÊNCIA DE CENTROS O e O' COM UM OUTRO ARCO DE CIRCUNFERÊNCIA DE RAIO r .

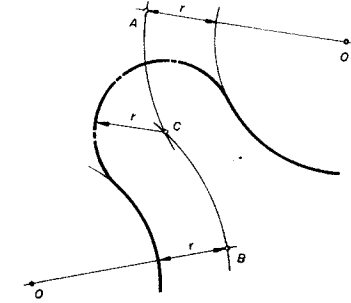

CONSTRUIR O TRIÂNGULO EQUILÁTERO DE LADO AB.

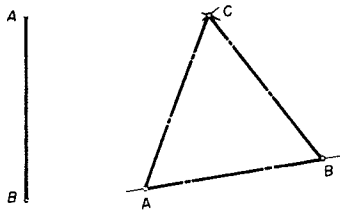

CONSTRUIR O TRIÂNGULO ISÓSCELES DE BASE AB E LADO AC.

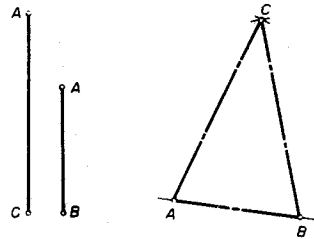

CONSTRUIR O TRIÂNGULO ESCALENO DE LADOS AB, BC e AC.

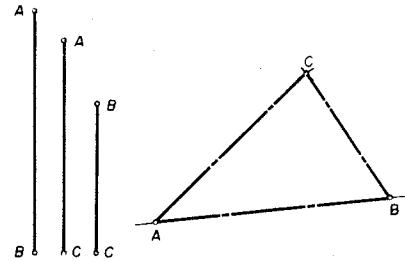

CONSTRUIR O TRIÂNGULO RETÂNGULO DE CATETOS AB e AG.

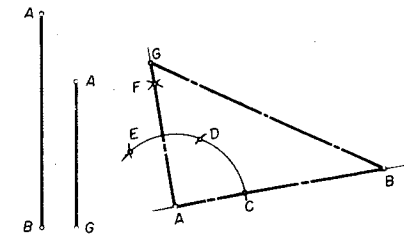

CONSTRUIR O QUADRADO DE LADO AB.

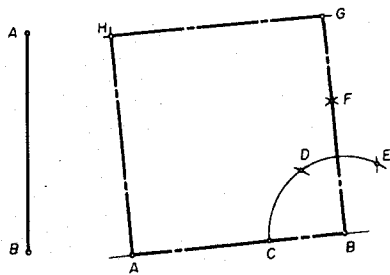

CONSTRUIR O RETÂNGULO DE LADOS AB e AG.

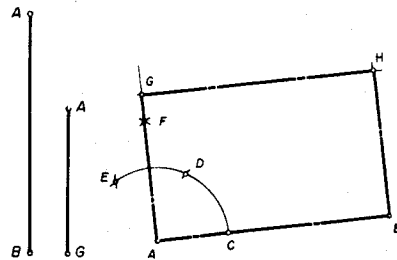

ACHAR O CENTRO H DA CIRCUNFERÊNCIA.

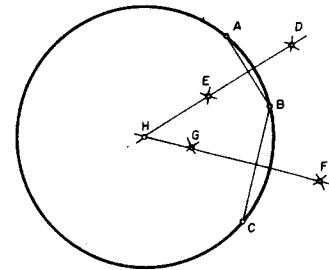

TRAÇAR O ARCO DE CIRCUNFERÊNCIA DE CENTRO O, QUE PASSA PELOS PONTOS ABC.

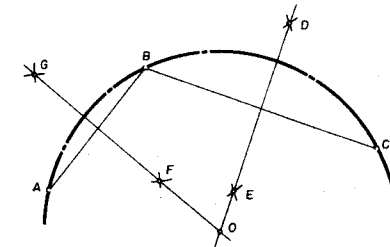

DIVIDIR A CIRCUNFERÊNCIA EM 3 PARTES IGUAIS, E INSCREVER O TRIÂNGULO EQUILÁTERO.

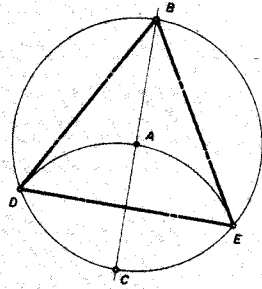

DIVIDIR A CIRCUNFERÊNCIA EM 4 PARTES IGUAIS, E INSCREVER O QUADRADO.

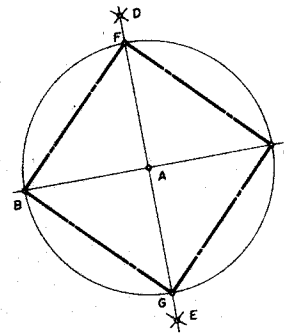

DIVIDIR A CIRCUNFERÊNCIA EM 5 PARTES IGUAIS, E INSCREVER O PENTÁGONO REGULAR.

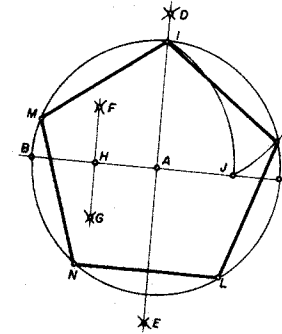

DIVIDIR A CIRCUNFERÊNCIA EM 6 PARTES IGUAIS, E INSCREVER O HEXÁGONO REGULAR.

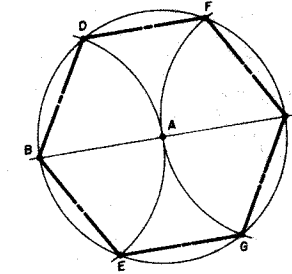

DIVIDIR A CIRCUNFERÊNCIA EM QUALQUER NÚMERO DE PARTES IGUAIS. EXEMPLO: 7 PARTES E INSCREVER O HEPTÁGONO REGULAR.

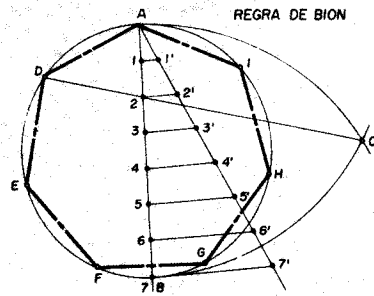

REGRA DE BION

DESENHAR A OVAL DADOS OS EIXOS AB E CD.

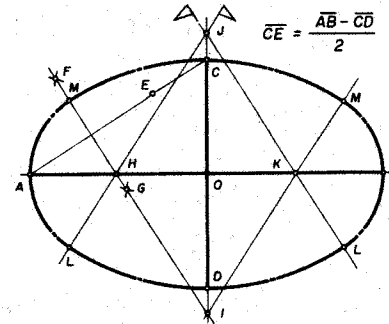

FI = eixo de AE HO = OK

DESENHAR A OVAL DADO O EIXO AB.

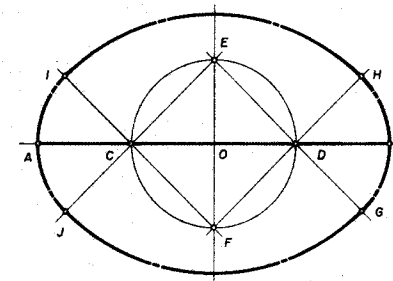

AC = CO = OD = DB = 1/4 AB

DESENHAR O ÓVULO DE 4 CENTROS COM O EIXO MENOR AB.

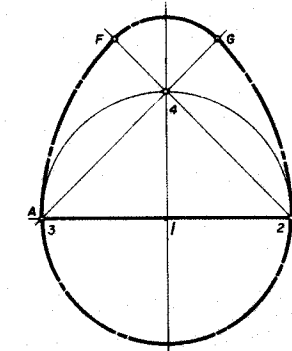

TRAÇAR A ESPIRAL DE DOIS CENTROS. SENTIDO HORÁRIO.

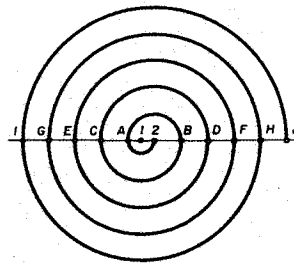

TRAÇAR A ESPIRAL DE TRÊS CENTROS. SENTIDO ANTI-HORÁRIO.

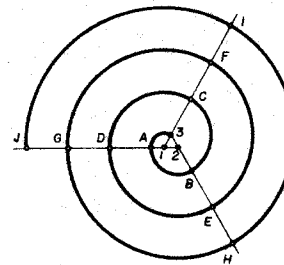

TRAÇAR A ESPIRAL DE QUATRO CENTROS. SENTIDO HORÁRIO.

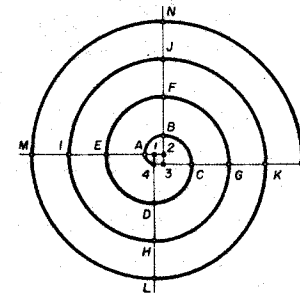

TRAÇAR A ESPIRAL DE ARQUIMEDIS. SENTIDO ANTI-HORÁRIO.

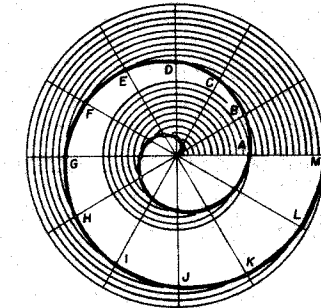

NB: A SEQUÊNCIA DOS TRAÇADOS OBEDECEM A ORDEM NUMÉRICA E ALFABÉTICA.

Retificar o arco OP menor que 90°

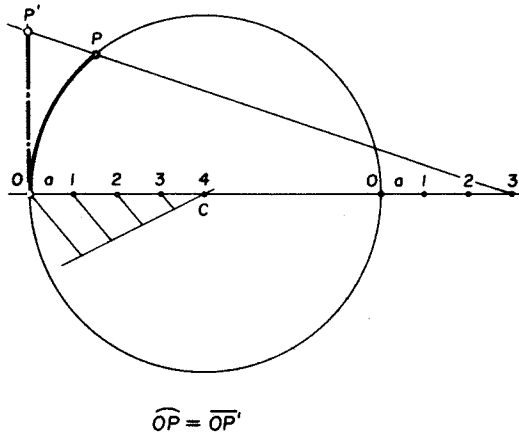

Retificar o arco OP maior que 90°
(processo D'OCAGNE)

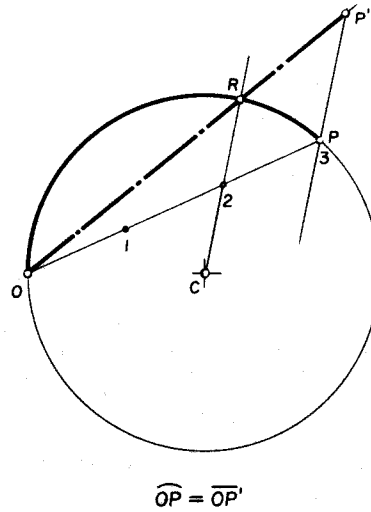

Retificar a semicircunferência OP de centro C e raio R .
(processo Kochansky)

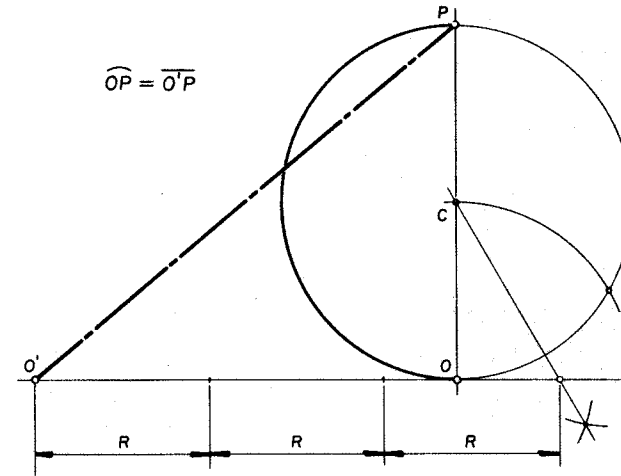

Retificar a circunferência de centro C .
(processo direto, aproximado)

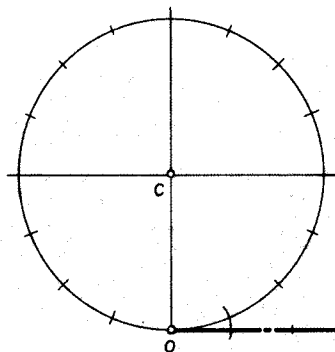

$OP = \text{circunferência retificada}$

Retificar a circunferência de centro C e diâmetro D .
(processo de Arquimedes)

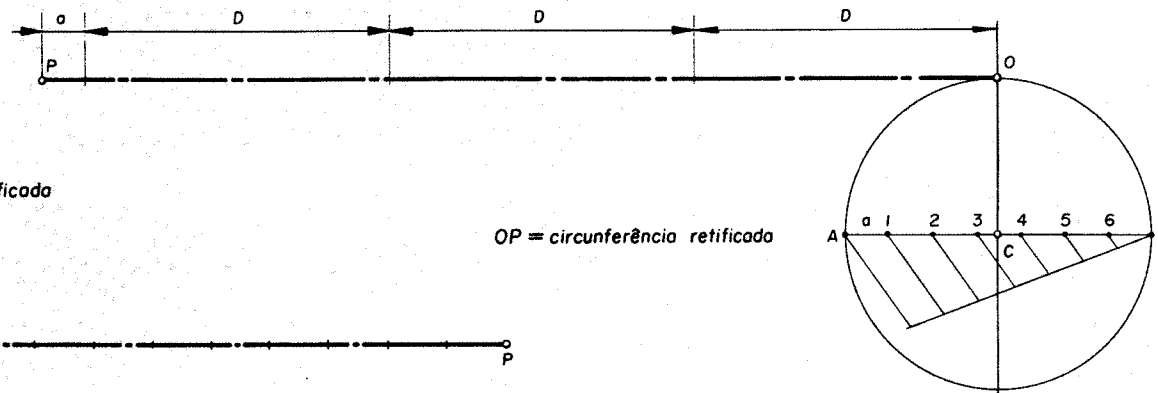

Dividir o segmento AB em partes proporcionais a : a, b, c, d, e, f.

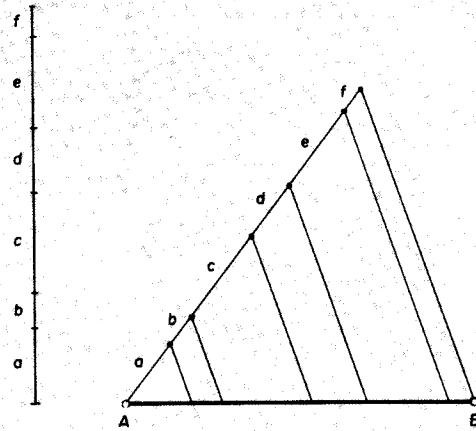

Achar a quarta proporcional dos segmentos AB, AC e AD.

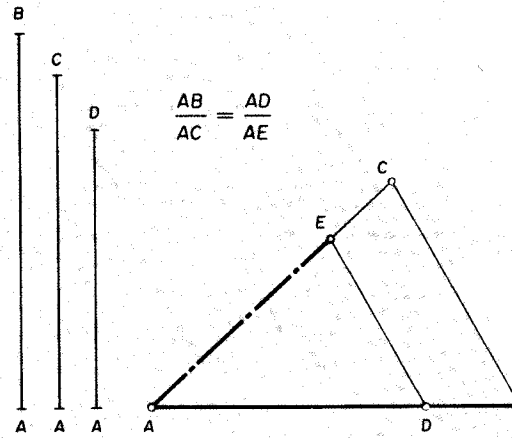

AE = quarta proporcional

Achar a terceira proporcional entre os segmentos AB e AC.

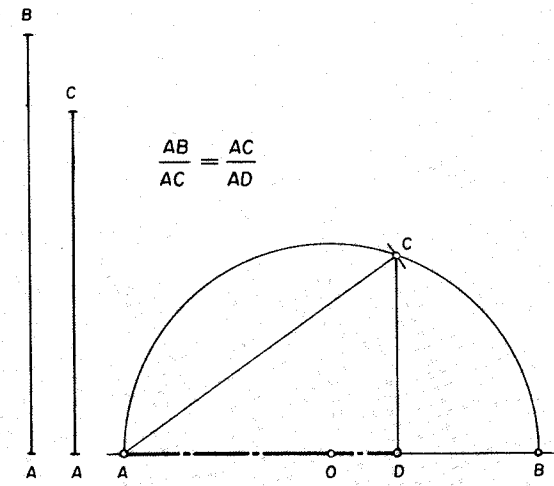

AD = terceira proporcional

Achar a média proporcional dos segmentos AB e BC.

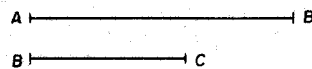
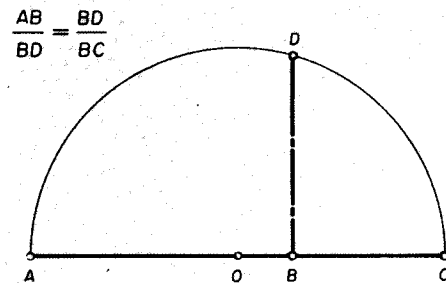

BD = média proporcional

Dividir o segmento AB em média e extrema razão (secção áurea).

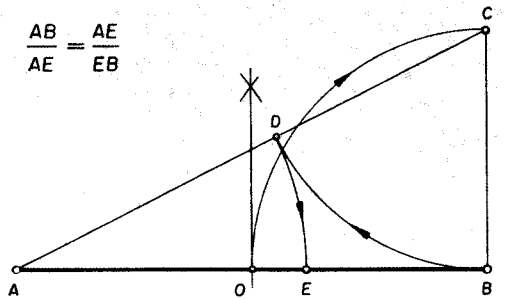

AE = segmento áureo

Teorema de Tales

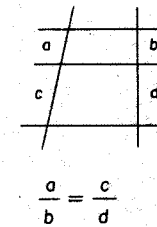

Teorema de Pitágoras

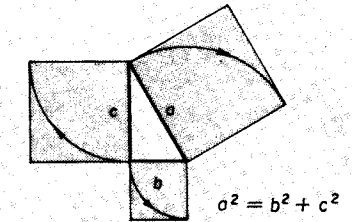

1º Teorema de Euclides

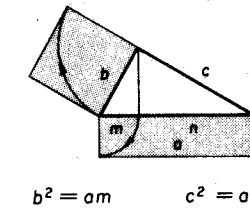

$b^2 = am$

2º Teorema de Euclides

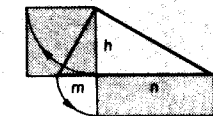

$h^2 = mn$

$c^2 = an$

USO DA CURVA FRANCESA

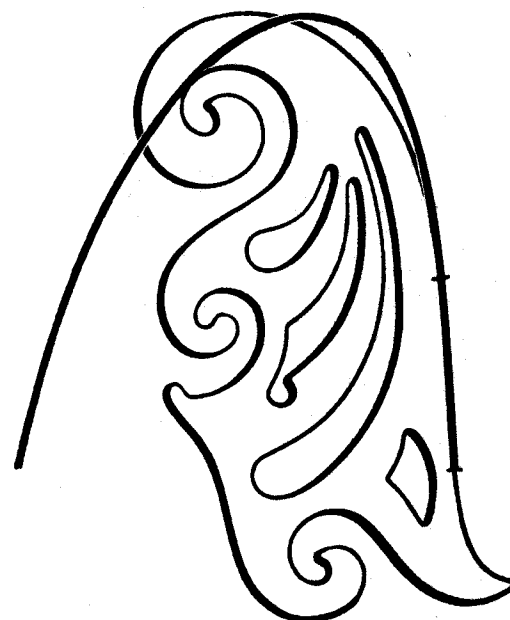
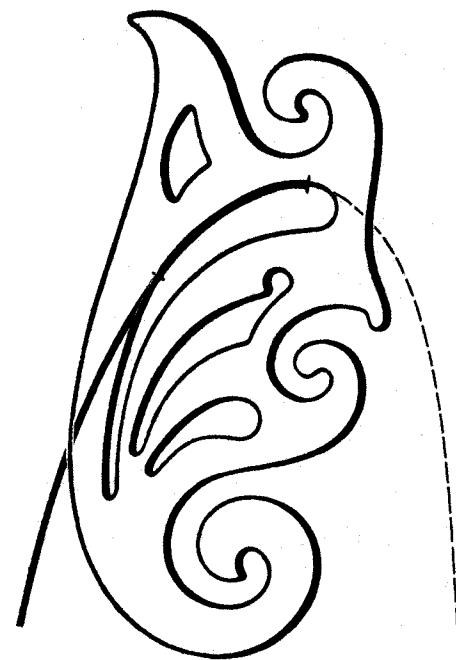
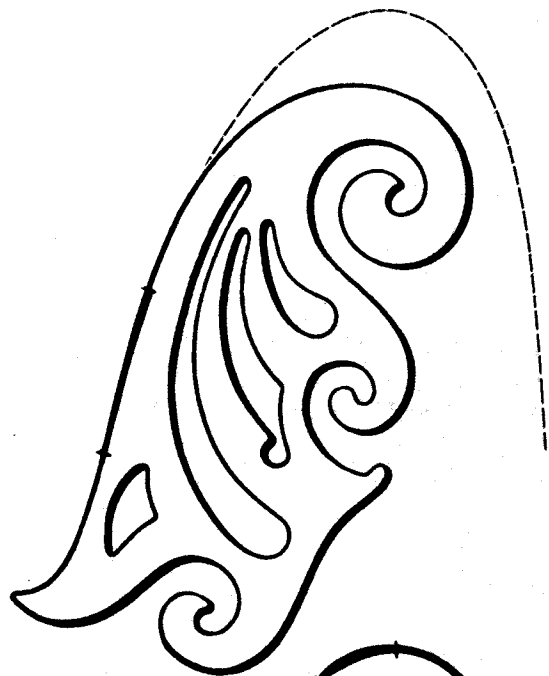

CÔNICAS

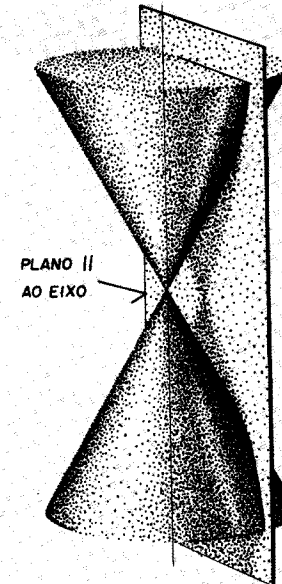
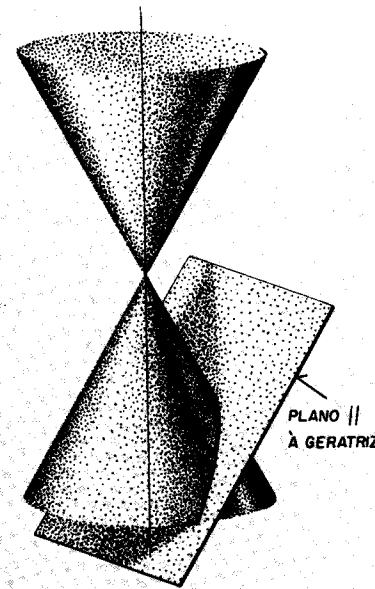
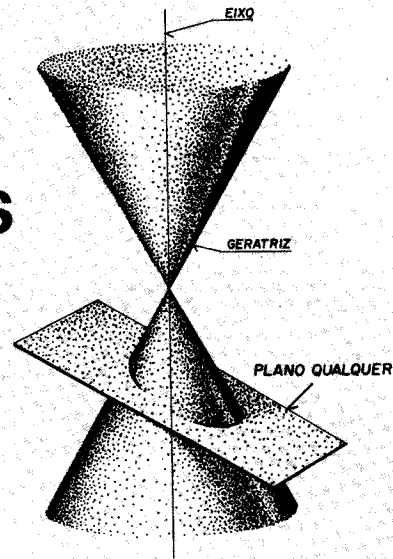

ELIPSE

DEFINIÇÃO: é uma curva plana fechada cuja soma das distâncias de qualquer de seus pontos aos focos F e F_1 é constante e igual ao eixo maior AB .

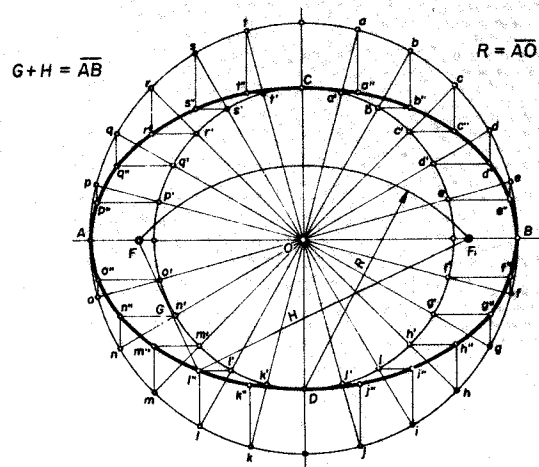

PARÁBOLA

DEFINIÇÃO: é uma curva plana aberta cujos pontos são equidistantes do foco e da diretriz.

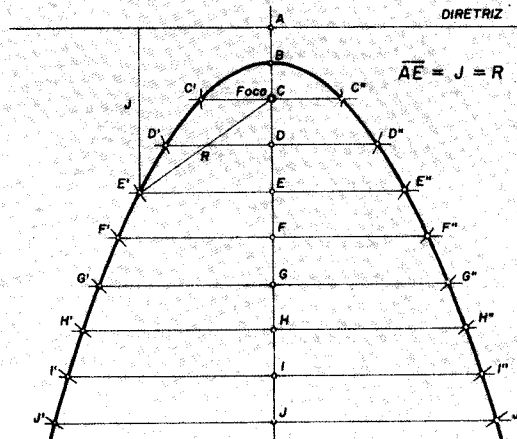

HIPÉRBOLE

DEFINIÇÃO: é uma curva plana constituída de duas partes simétricas cujos pontos têm diferença constante entre as distâncias delas aos focos F e F_1 e igual à distância entre os vértices A e A_1 .

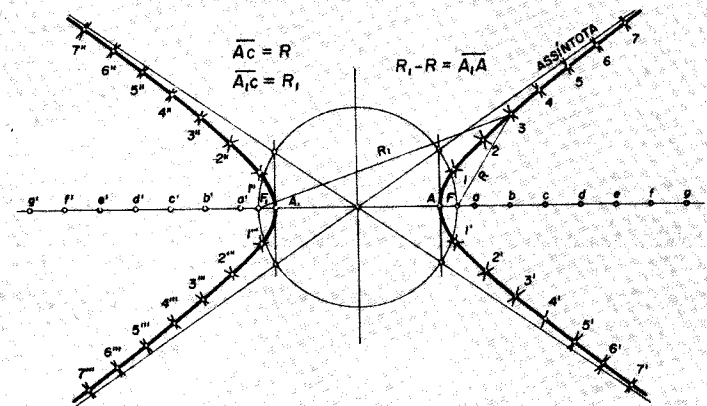

HÉLICES

HÉLICE

CILÍNDRICA

DEFINIÇÃO: é a curva gerada por um ponto em movimento uniforme ao longo da geratriz que está em movimento de rotação uniforme em torno do eixo.

PASSO: é o segmento da geratriz entre duas passagens consecutivas da hélice

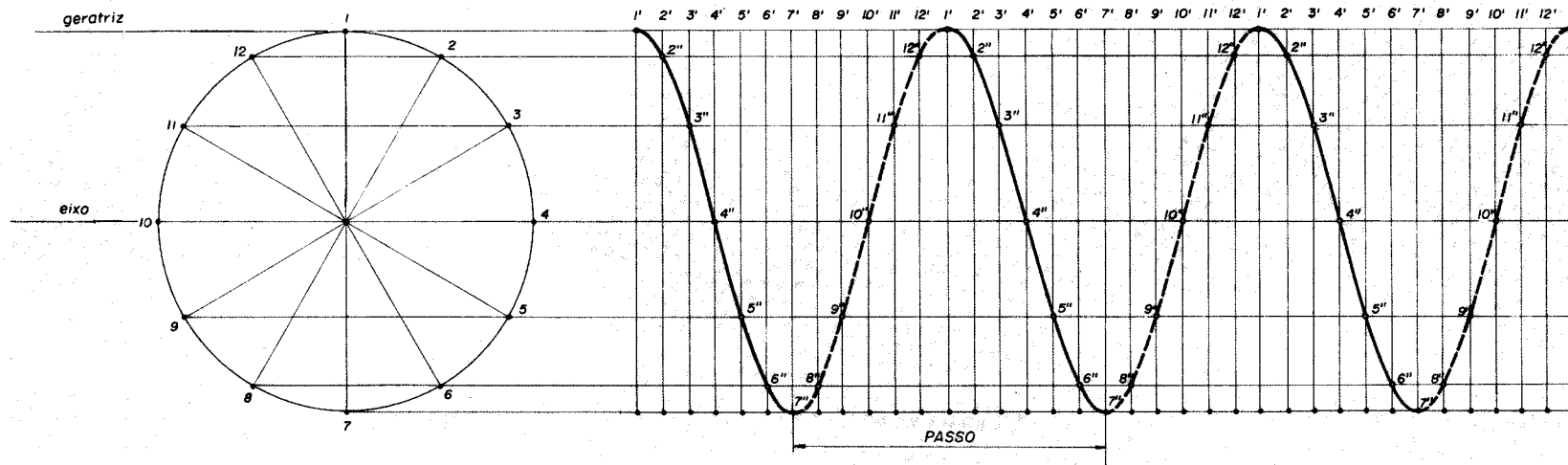

HÉLICE

CÔNICA

DEFINIÇÃO: é a curva gerada por um ponto em movimento uniforme ao longo da geratriz que está em movimento de rotação uniforme em torno do eixo.

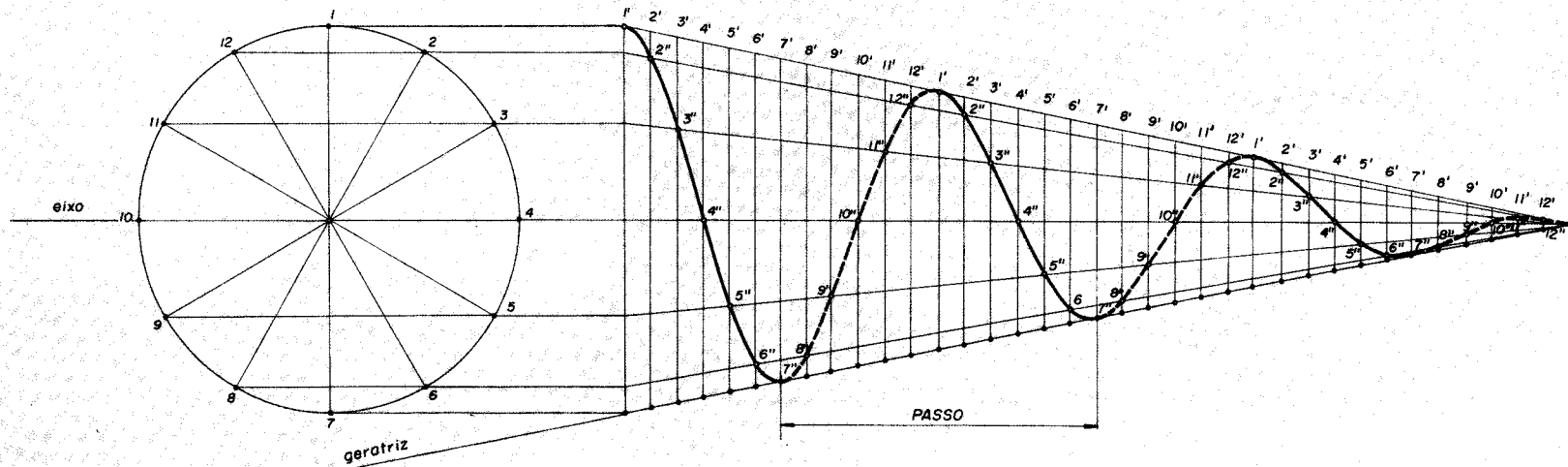

CICLÓIDE

DEFINIÇÃO: é a curva gerada por um ponto de uma circunferência que rola sobre uma reta, sem escorregar.

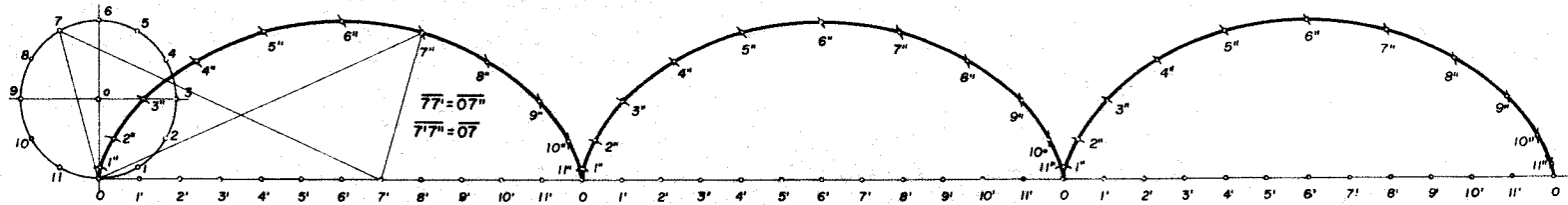

CÍCLICAS

EVOLVENTE

DEFINIÇÃO: é a curva gerada por um ponto de uma reta em rotação sobre uma circunferência.

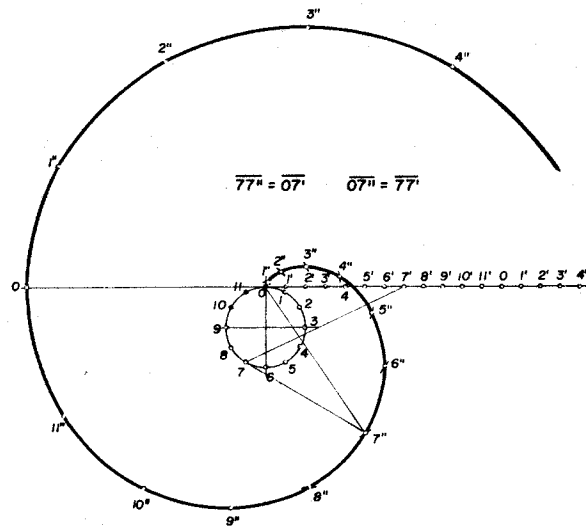

EPICICLÓIDE

DEFINIÇÃO: é a curva gerada por um ponto de uma circunferência que rola exteriormente à outra, sem escorregar.

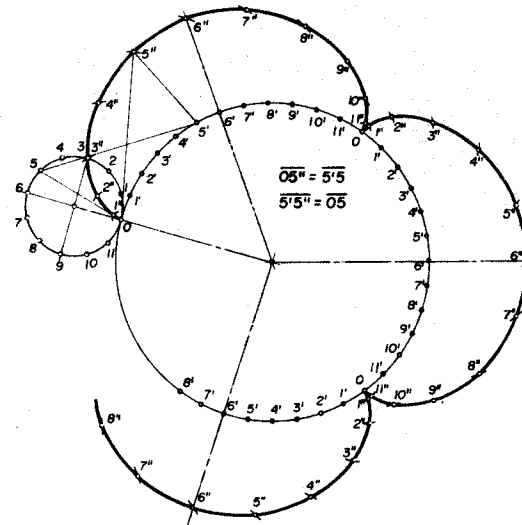

HIPOCICLÓIDE

DEFINIÇÃO: é a curva gerada por um ponto de uma circunferência que rola interiormente à outra, sem escorregar.

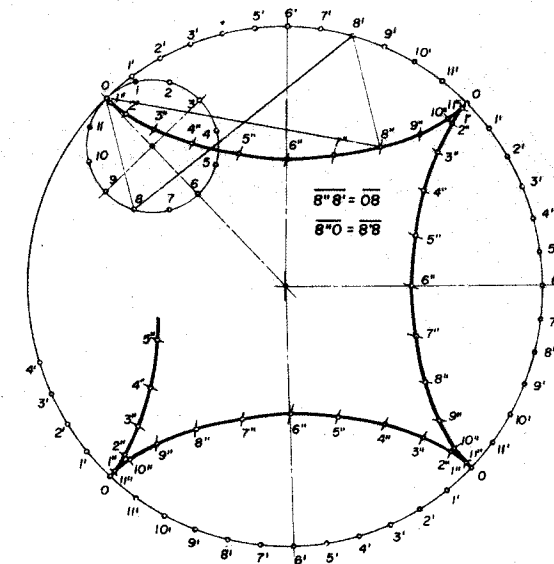

CONCOIDES OU CONCHOIDES

São curvas planas semelhantes às conchas.

1 - CONCOIDES DE UMA RETA

- 1ª Traçar a reta r chamada BASE e o ponto P POLO, distante a da reta r .
- 2ª Estabelecer o valor do INTERVALO k .
- 3ª Marcar k em ambos os lados do ponto de INTERSEÇÃO da reta r e com as retas que passam pelo polo P .

Dependendo do valor de k , teremos:

- para $k > a$ concoide com nó
- $k = a$ " " cúspide
- $k < a$ " " Polo externo

A equação polar da Concoide de NICODEME é:

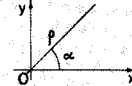
$$\rho = \frac{a}{\cos \alpha} \pm k$$

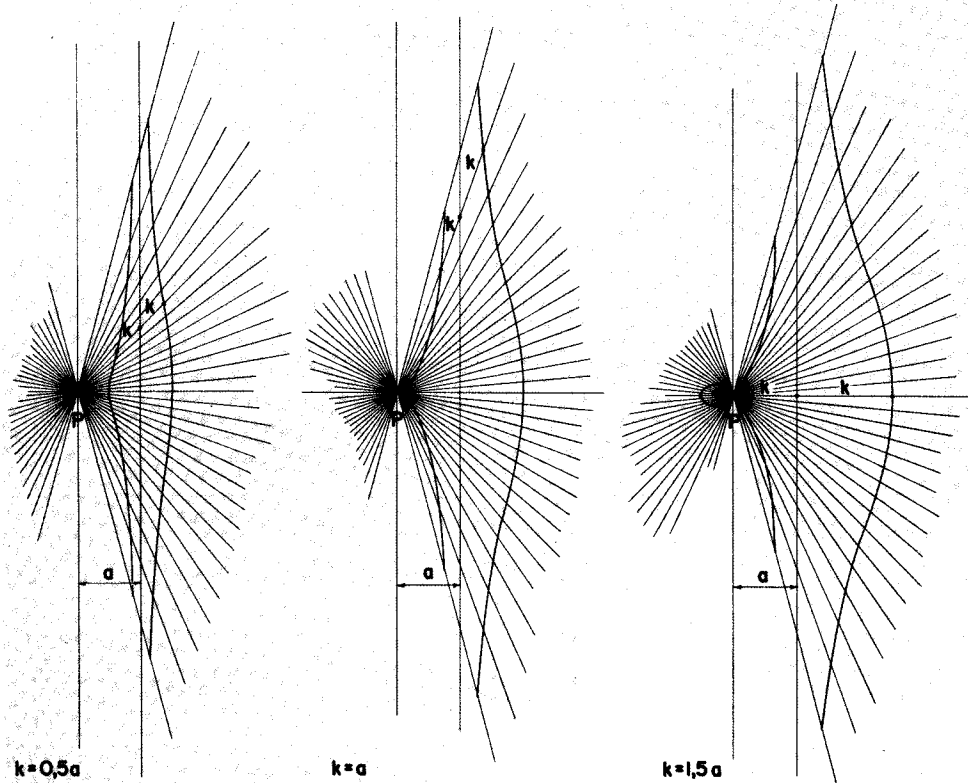

2 - CONCOIDES DE UMA CIRCUNFERENCIA

O TRAÇADO anterior pode ser generalizada, substituindo a reta de Base com uma outra linha curva qualquer.

Adotando como BASE a Circunferencia de diametro a e como Polo P , um ponto da circunferencia BASE e obedecendo a mesma sequencia vista anteriormente, temos as Concoides abaixo:

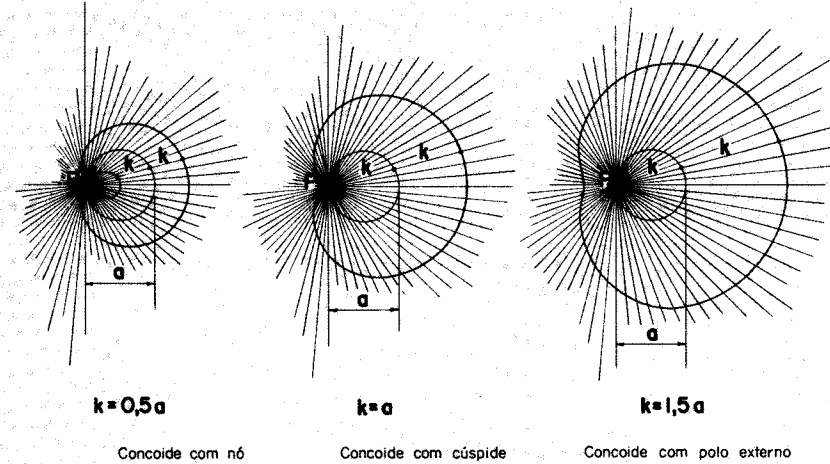

Nota-se que as curvas, dependendo do intervalo k , têm as mesmas características das concoides de reta Base,

Estas curvas são conhecidas como CARAMUJOS DE PASCAL

A EQUAÇÃO POLAR é:

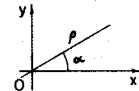
$$\rho = a \cdot \cos \alpha \pm k$$

CARDÍOIDE

É a concoide em que $k = a$, parecida com o coração e corresponde a um Epicicloide.

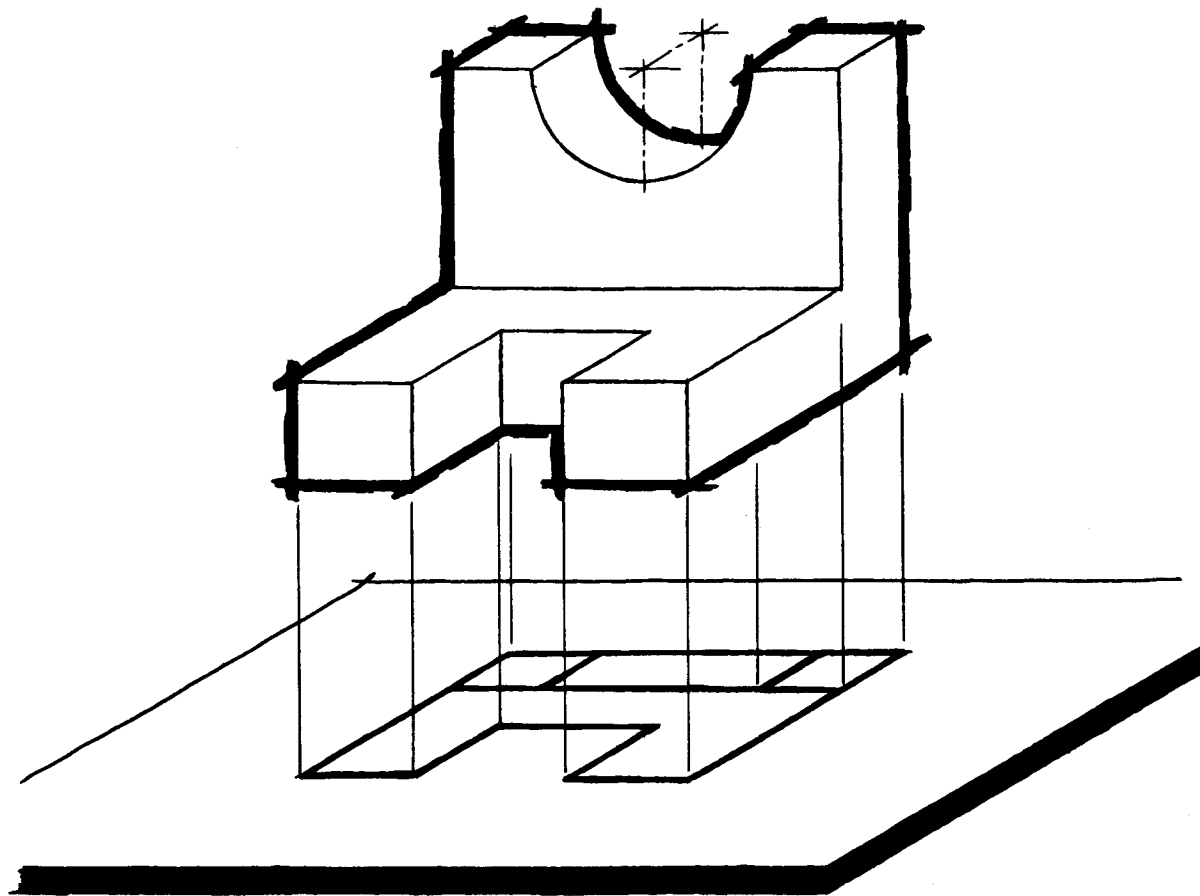

3 projeções ortogonais

norma
americana

norma
européia



PROJEÇÃO ORTOGONAL

NORMA EUROPÉIA adotada pela ABNT
(Associação Brasileira de Normas Técnicas)

De acordo com esta norma, o objeto se localiza na frente do plano do desenho.

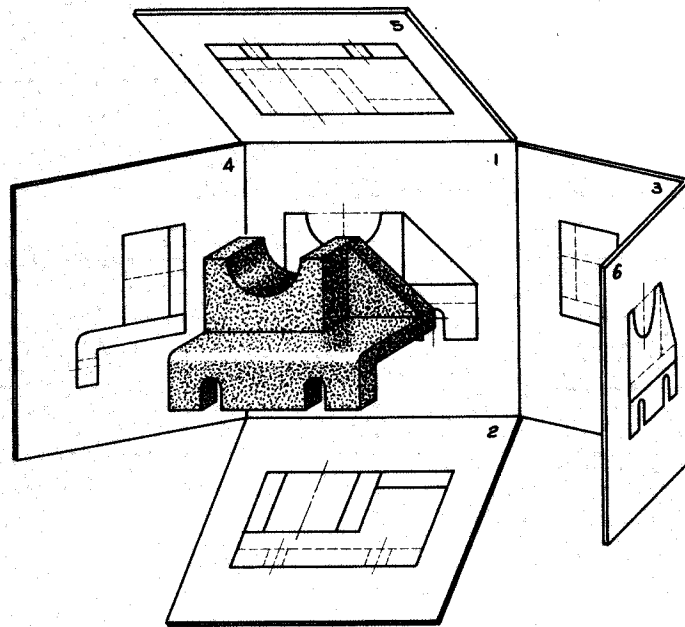

- 1 - PLANO VERTICAL
vista de frente ou elevação
- 2 - PLANO HORIZONTAL
vista de cima ou planta
- 3 - PLANO DE PERFIL
vista do lado esquerdo ou perfil
- 4 - PLANO DE PERFIL
vista do lado direito
- 5 - PLANO HORIZONTAL
vista de baixo
- 6 - PLANO VERTICAL
vista de trás

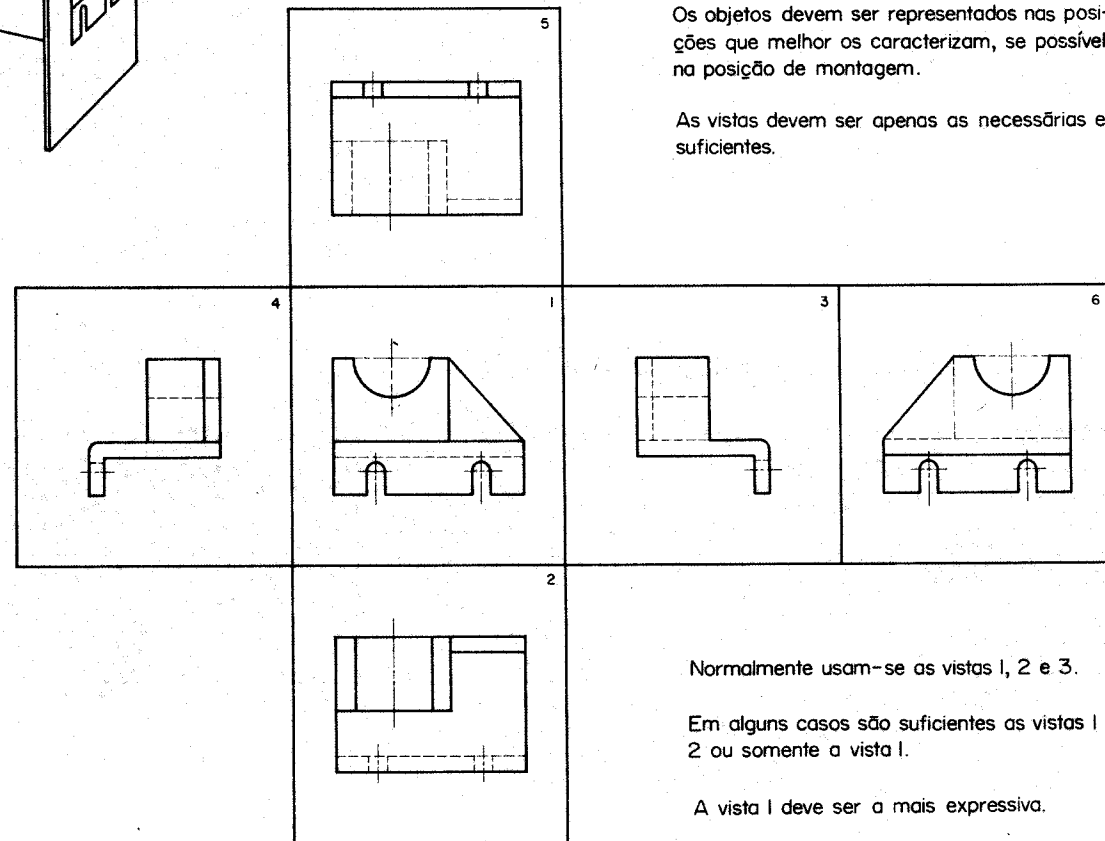

Os objetos devem ser representados nas posições que melhor os caracterizam, se possível, na posição de montagem.

As vistas devem ser apenas as necessárias e suficientes.

Normalmente usam-se as vistas 1, 2 e 3.

Em alguns casos são suficientes as vistas 1 e 2 ou somente a vista 1.

A vista 1 deve ser a mais expressiva.

EXEMPLOS

PROJEÇÃO DO PONTO A

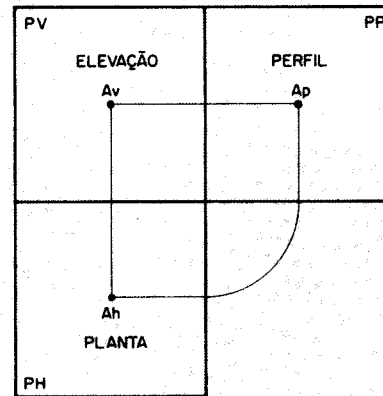
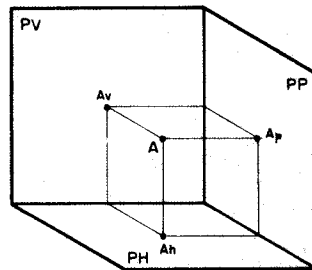

PROJEÇÃO DO SEGMENTO AB

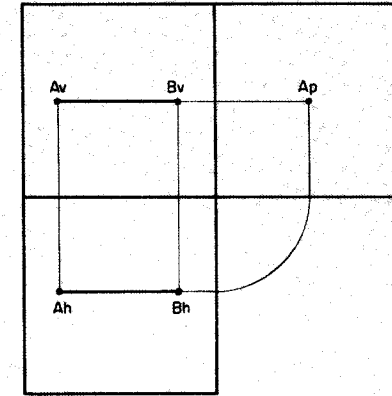
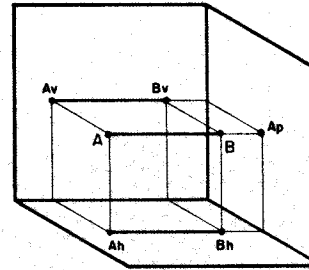

PV = plano vertical
 PP = plano de perfil
 PH = plano horizontal

PROJEÇÃO DO POLÍGONO ABCDEF

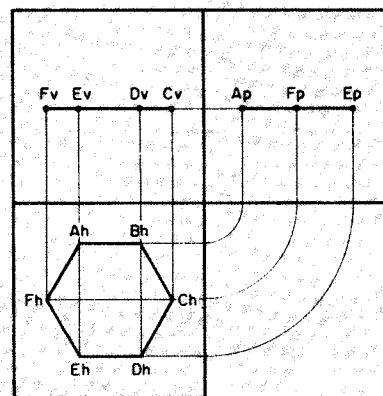
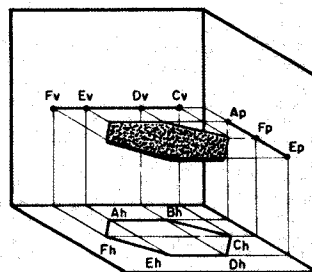

PROJEÇÃO DO PRISMA

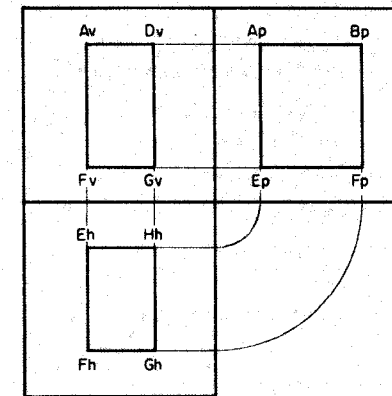
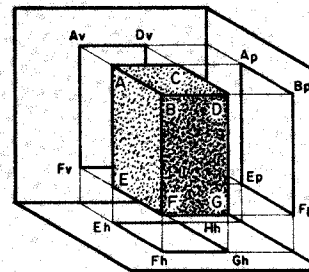

PROJEÇÃO DA PIRÂMIDE

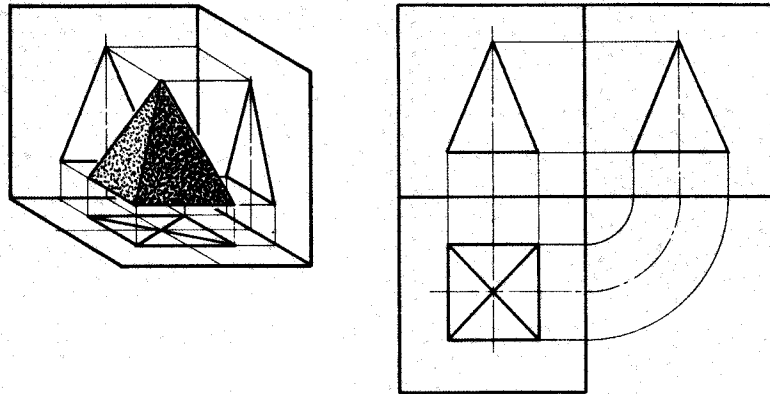

PROJEÇÃO DO CILINDRO

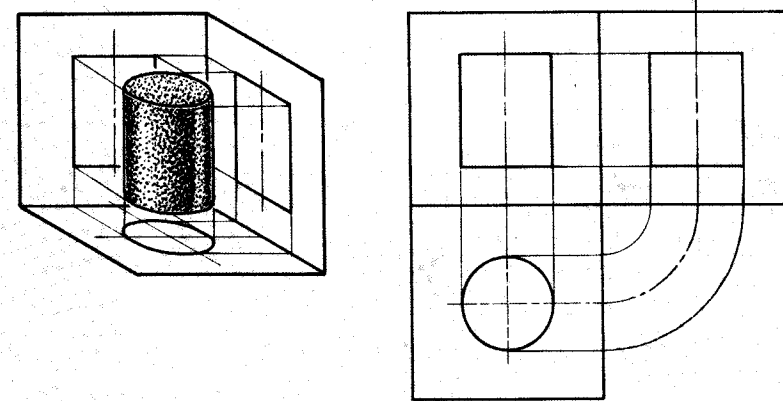

PROJEÇÃO DO CONE

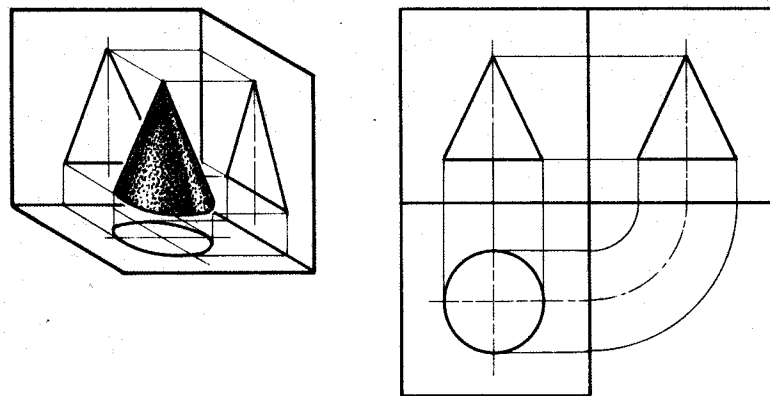

PROJEÇÃO DE UMA PEÇA

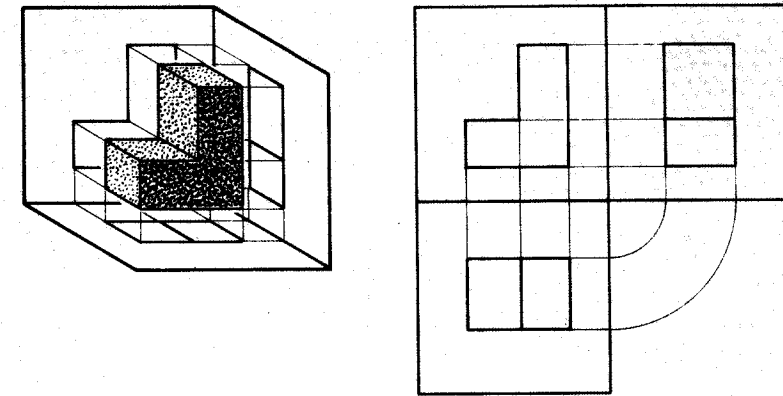

REPRESENTAÇÃO EM DUAS VISTAS

Alguns destes exemplos podem ser representados com uma vista apenas, se forem observados as "Normas e Convenções."

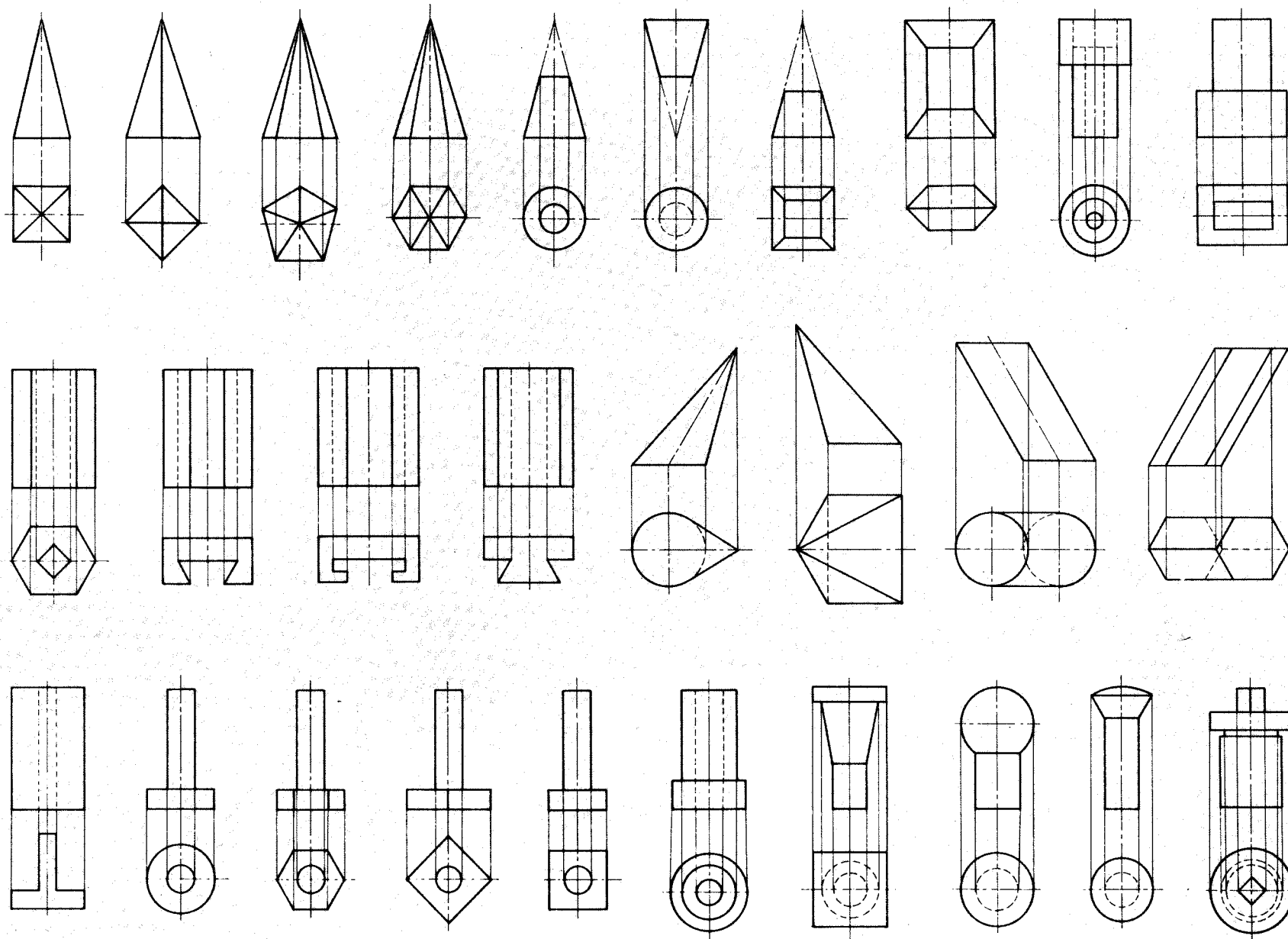

Alguns destes exemplos podem ser representados com duas vistas apenas, se forem observadas as "Normas e Convencões".

REPRESENTAÇÃO EM TRES VISTAS

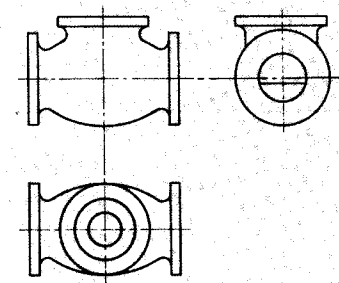
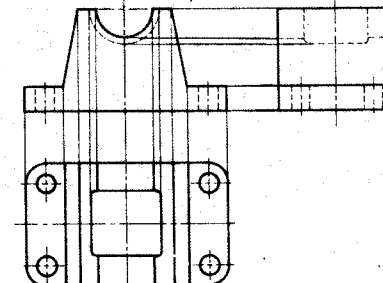
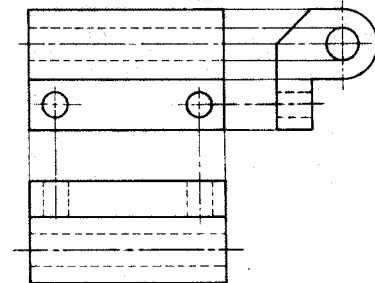
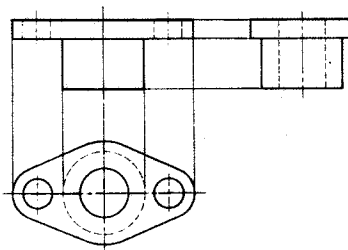
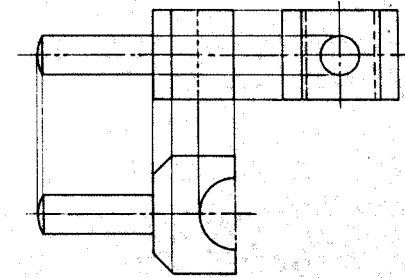
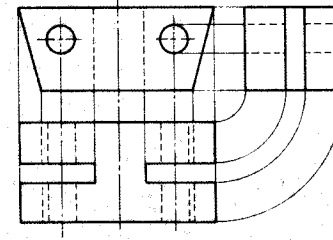
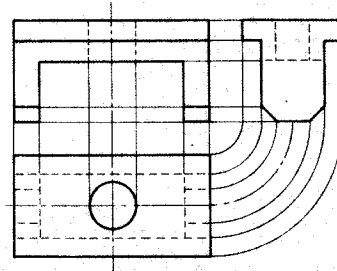
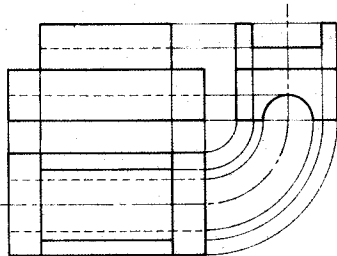
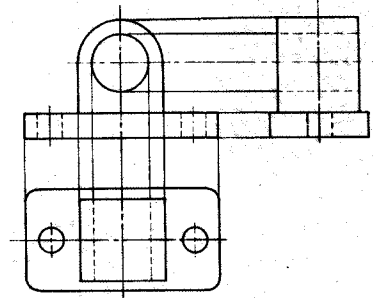
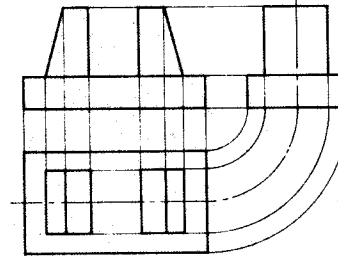
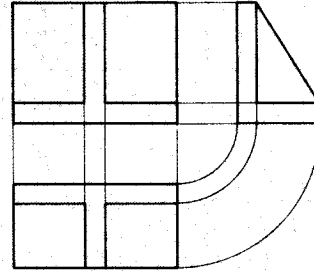
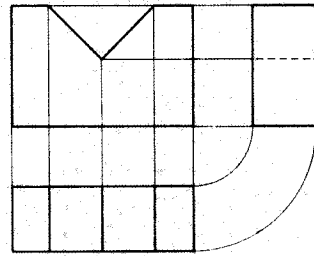

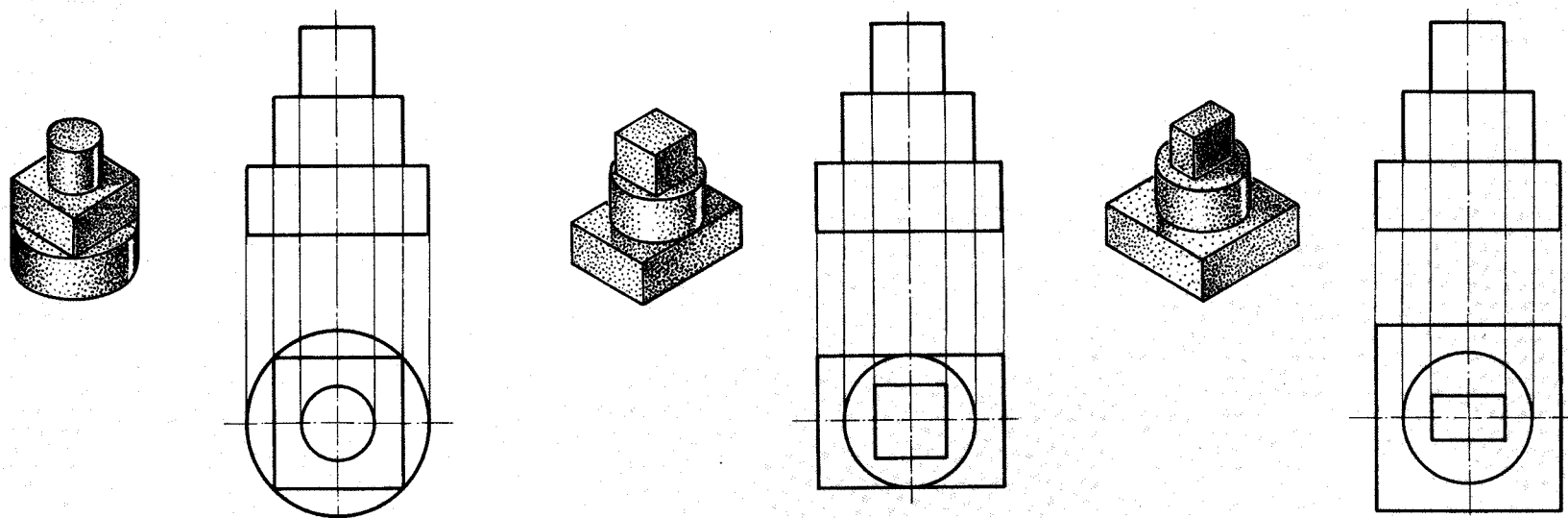

As vistas devem ser apenas as necessárias e suficientes.

Para a representação completa de uma peça, às vezes, há necessidade de pelo menos duas vistas. Nas representações acima, as três peças, apesar de serem diferentes, têm as mesmas elevações.

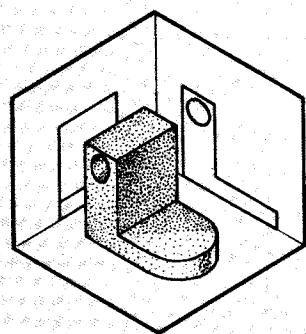

Para representar a peça nesta posição, são necessárias três vistas.

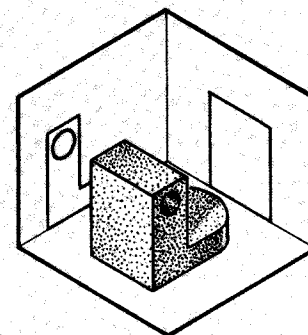
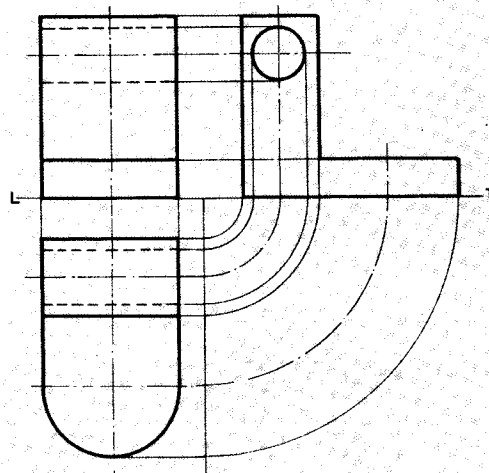

Nesta posição são suficientes apenas duas vistas.

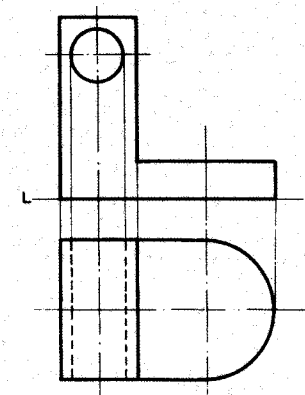

ELEMENTOS INCLINADOS C/ OS PLANOS DE PROJEÇÃO

Peça inclinada em relação ao PH e paralela ao PV.

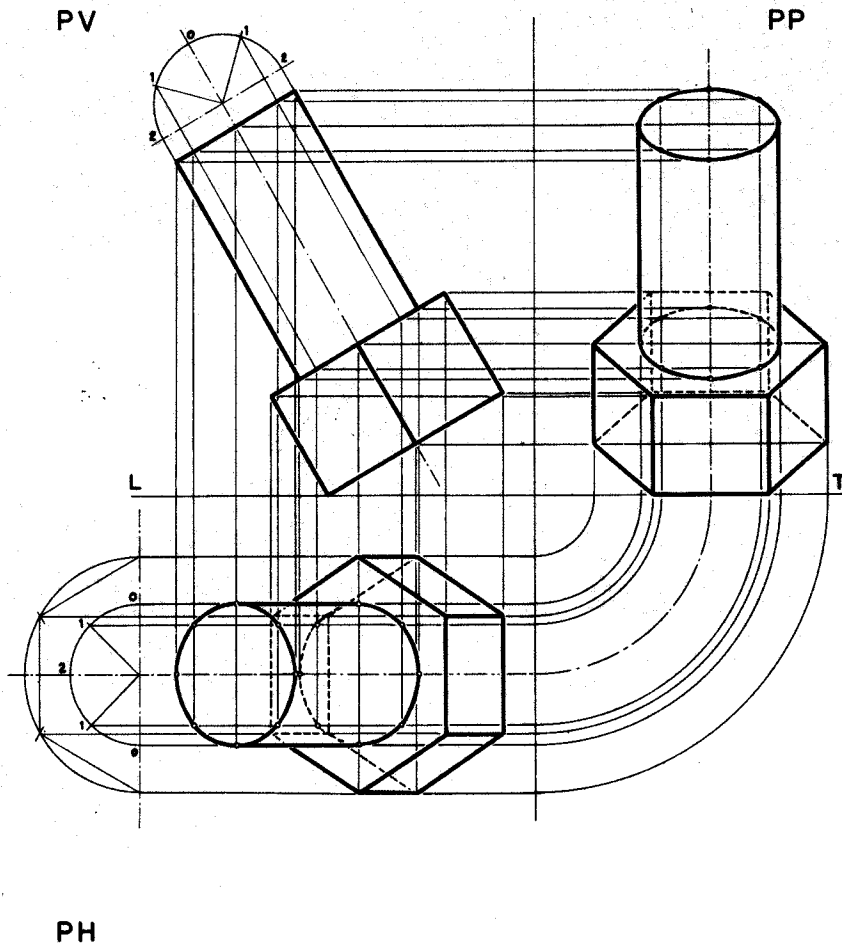

Peça inclinada em relação ao PV e paralela ao PH.

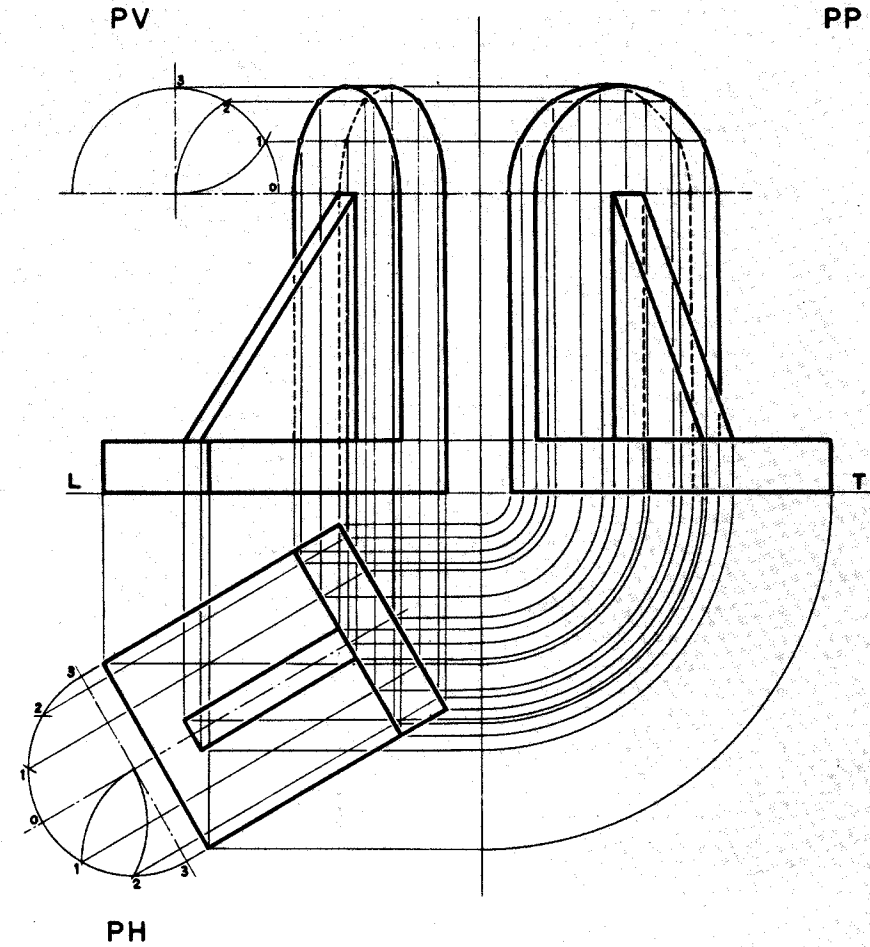

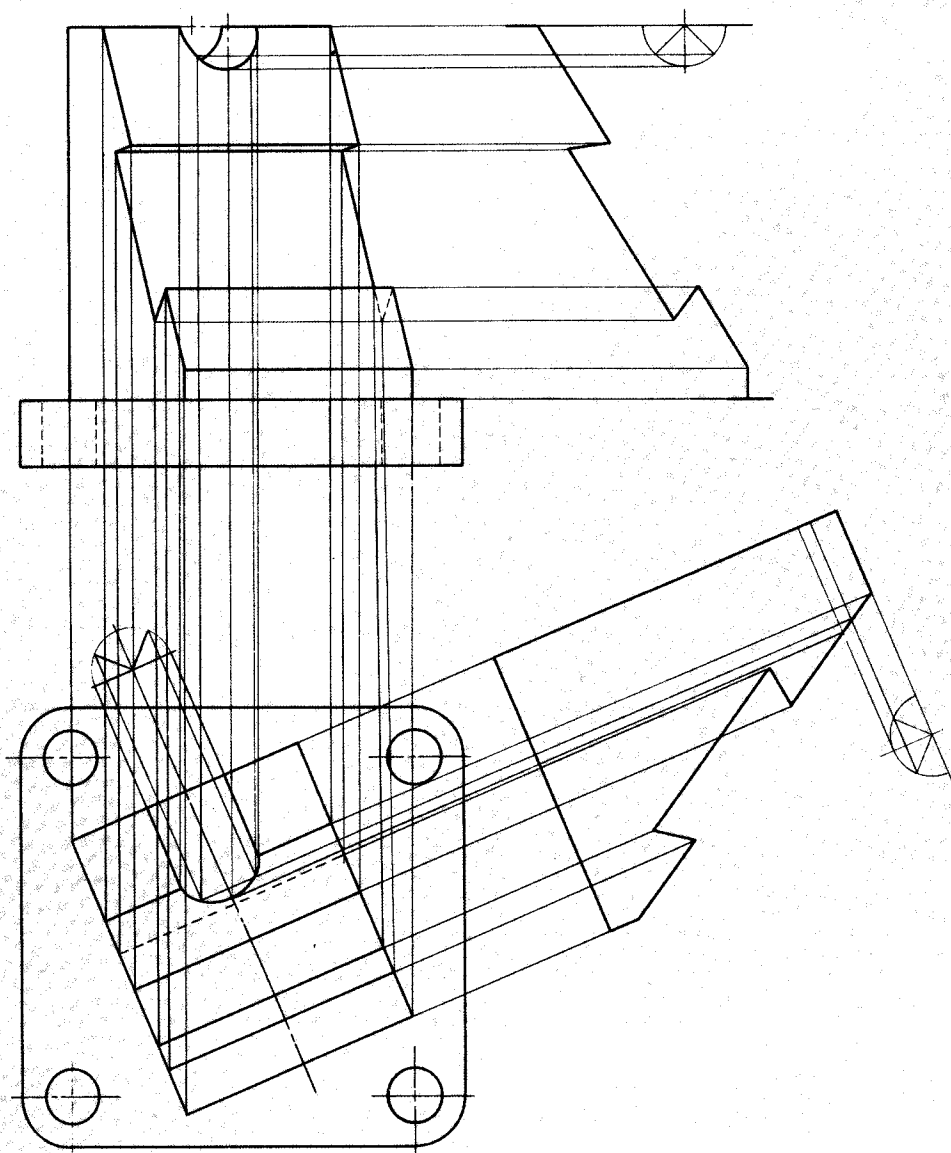

EXEMPLO

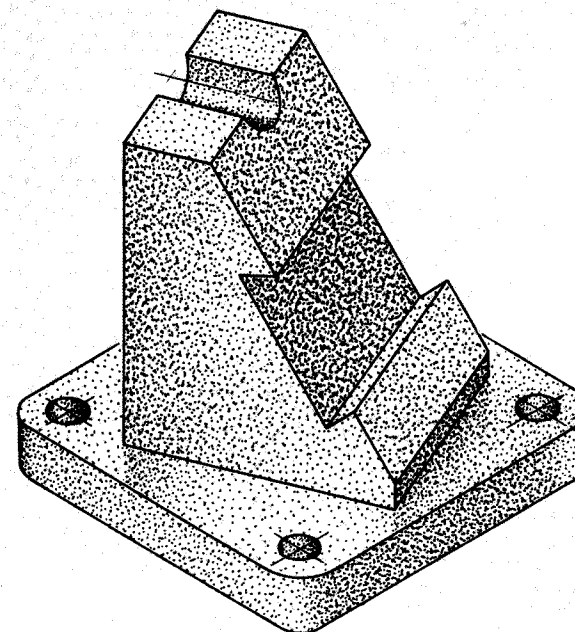

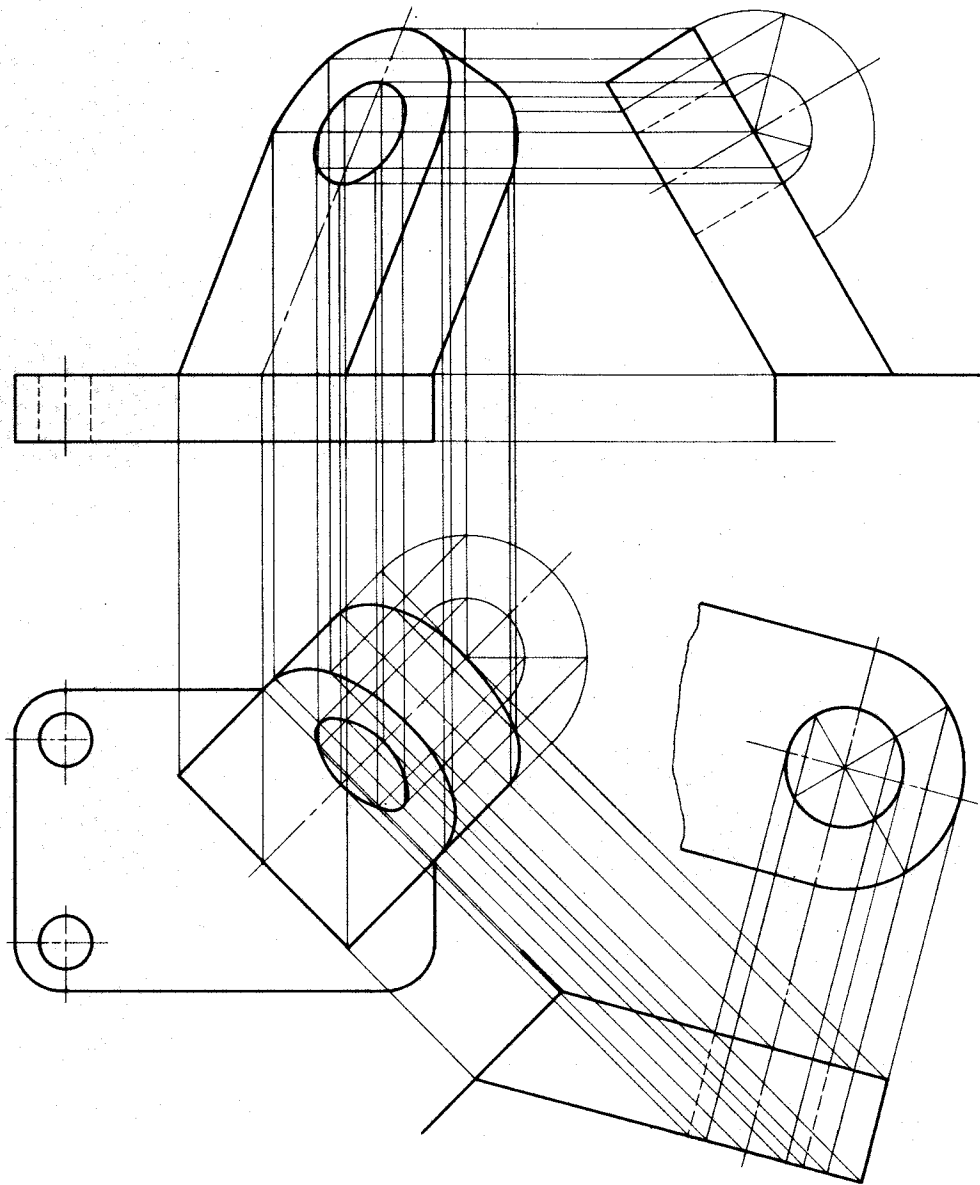

EXEMPLO

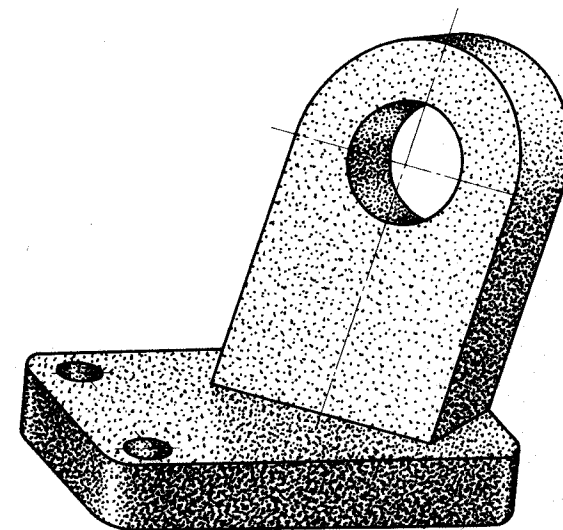

PROJEÇÃO ORTOGONAL

NORMA NORTE - AMERICANA

De acordo com esta norma, o objeto se localiza atrás do plano do desenho.

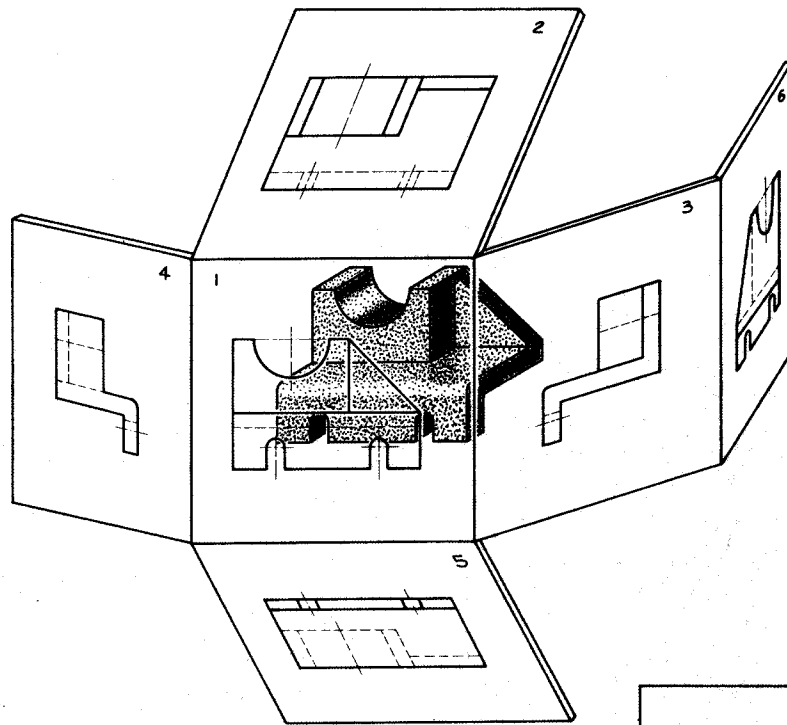

- 1 - PLANO VERTICAL
vista de frente ou elevação
- 2 - PLANO HORIZONTAL
vista de cima ou planta
- 3 - PLANO DE PERFIL
vista do lado direito ou perfil
- 4 - PLANO DE PERFIL
vista do lado esquerdo
- 5 - PLANO HORIZONTAL
vista de baixo
- 6 - PLANO VERTICAL
vista de trás

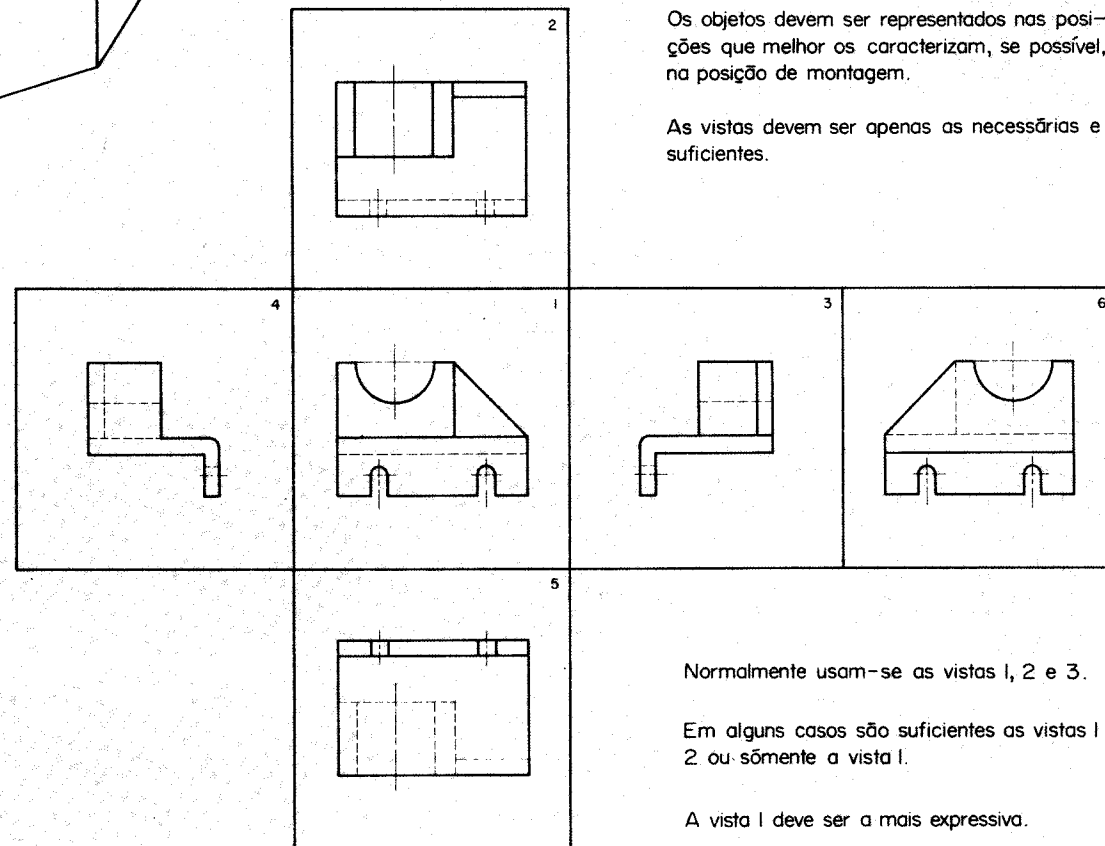

Os objetos devem ser representados nas posições que melhor os caracterizam, se possível, na posição de montagem.

As vistas devem ser apenas as necessárias e suficientes.

Normalmente usam-se as vistas 1, 2 e 3.

Em alguns casos são suficientes as vistas 1 e 2 ou somente a vista 1.

A vista 1 deve ser a mais expressiva.

MÉTODOS DE PROJEÇÃO ORTOGONAL

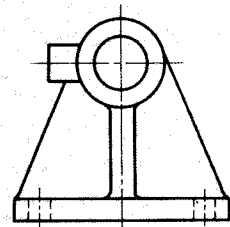

elevação

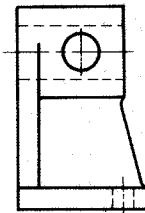

perfil

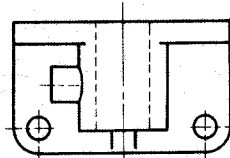

planta

MÉTODO EUROPEU

1º diedro

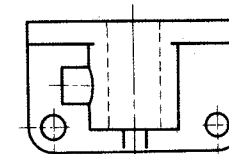
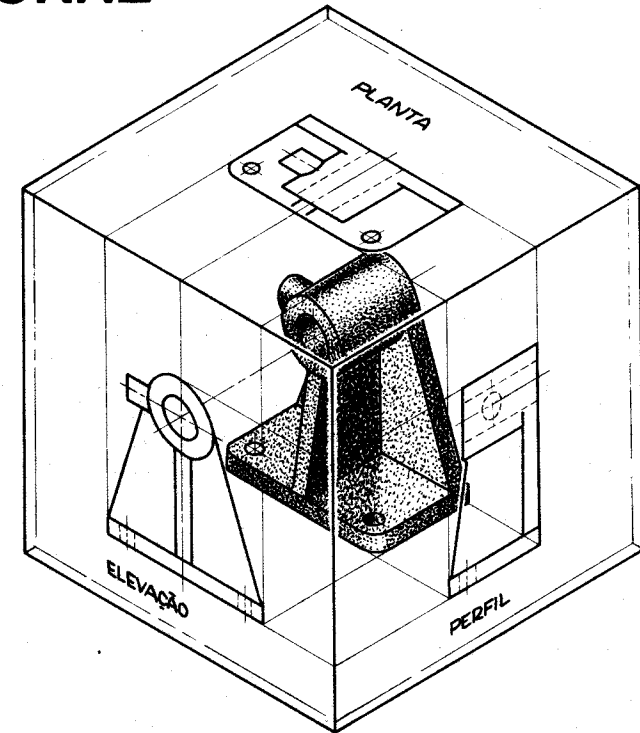
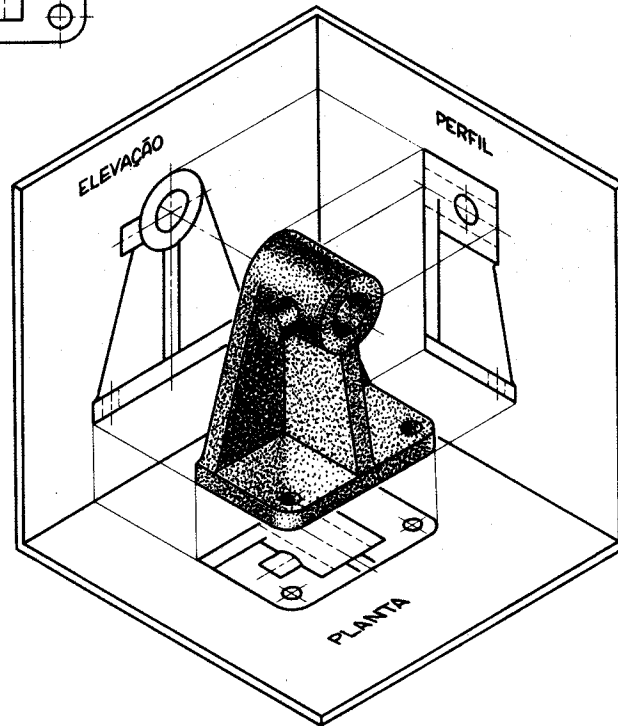

planta

MÉTODO NORTE-AMERICANO

3º diedro

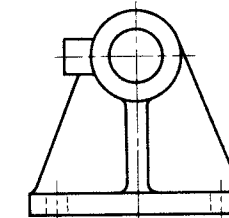

elevação

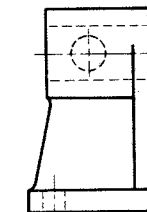

perfil

COMPARAÇÃO

1º diedro

3º diedro

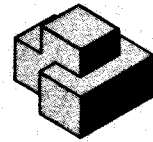
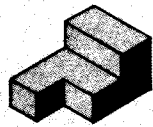
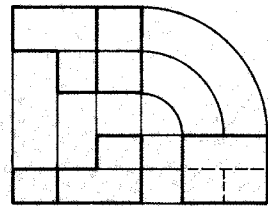
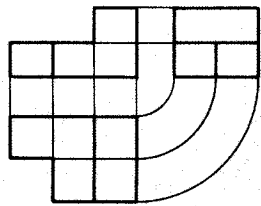

1º diedro

3º diedro

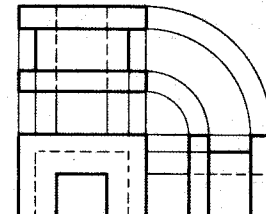
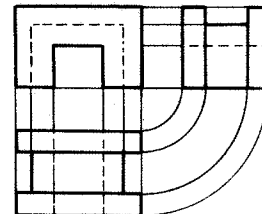
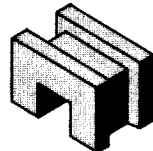
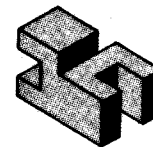
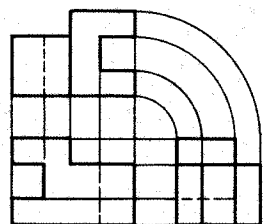
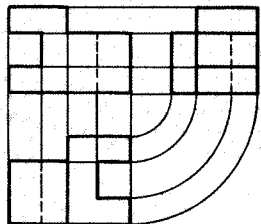
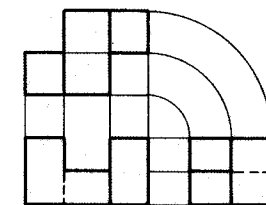
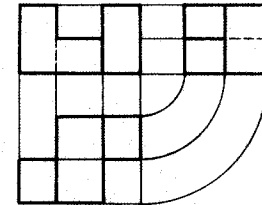
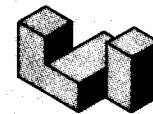
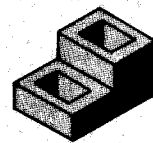
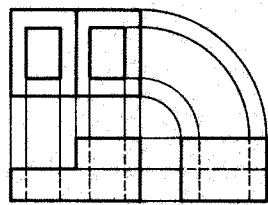
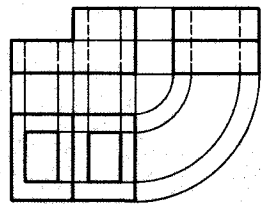
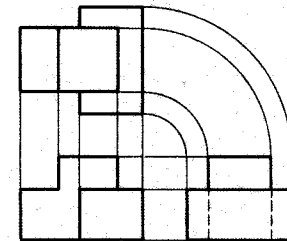
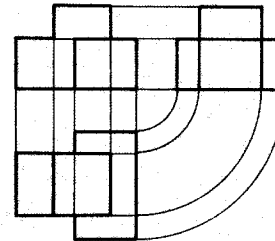

1º diedro

3º diedro

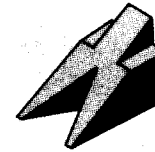
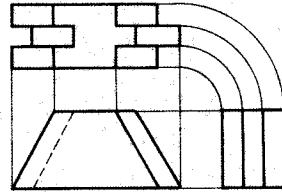
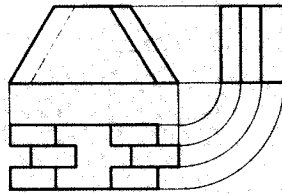

1º diedro

3º diedro

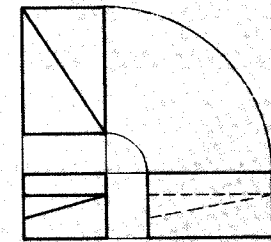
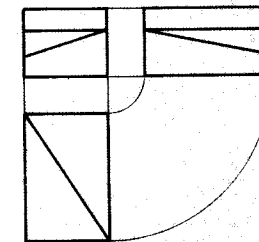
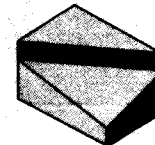
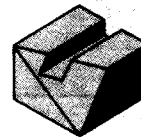
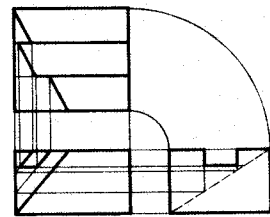
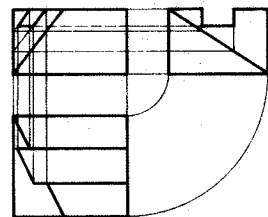
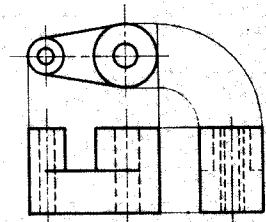
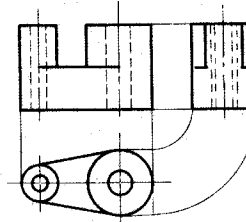
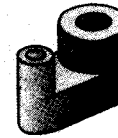
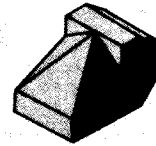
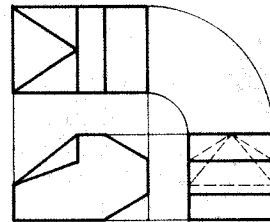
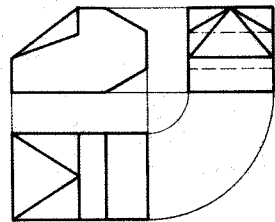
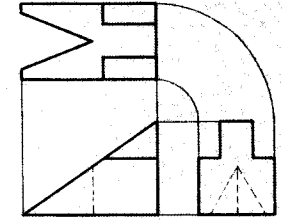
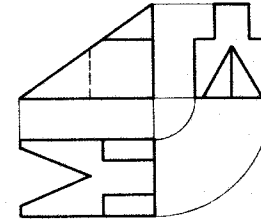

1º diedro

3º diedro

1º diedro

3º diedro

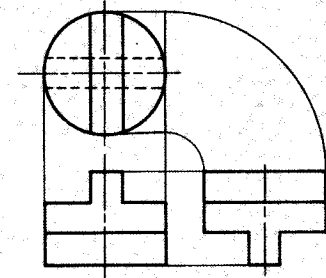
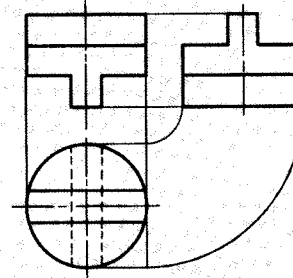
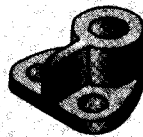
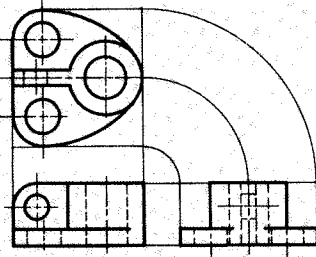
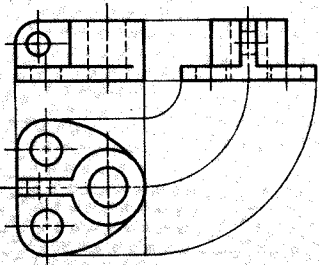
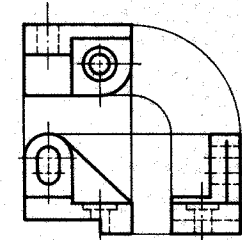
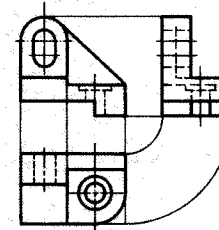
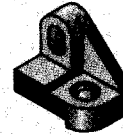
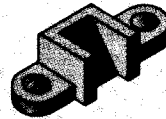
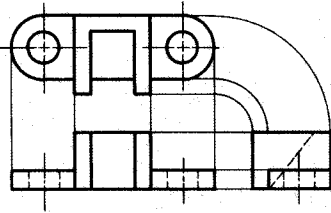
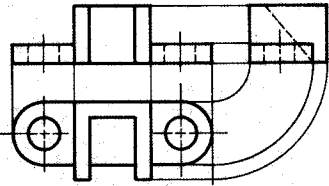
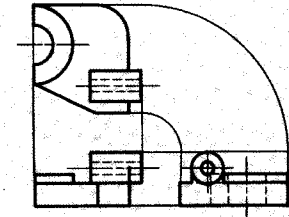
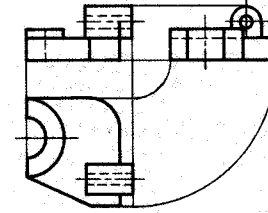
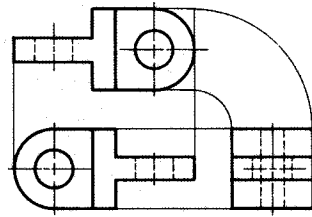
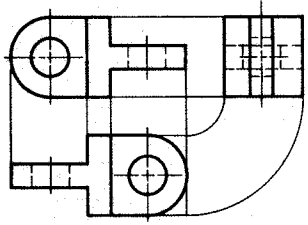

1º diedro

3º diedro

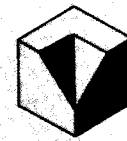
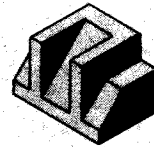
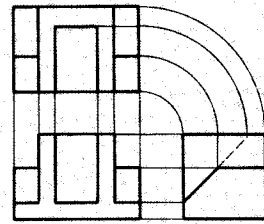
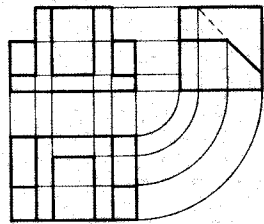

1º diedro

3º diedro

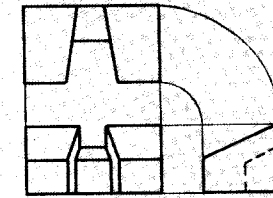
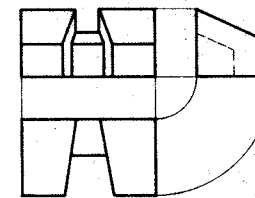
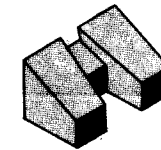
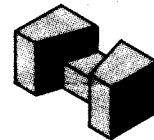
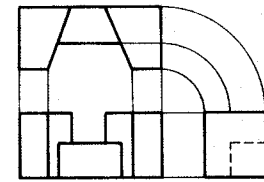
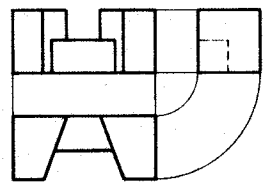
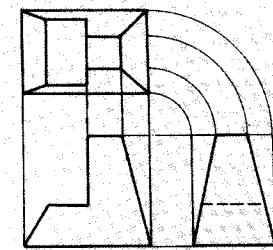
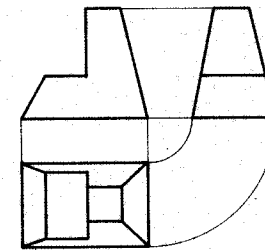
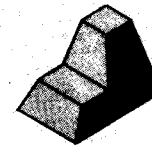
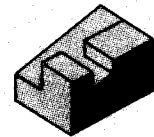
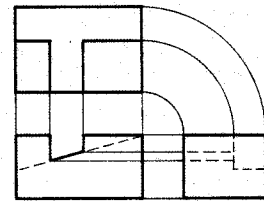
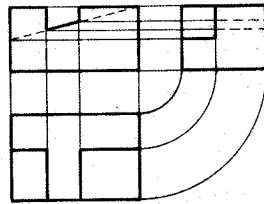
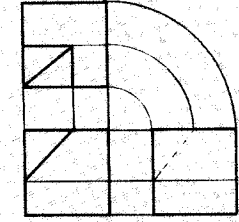
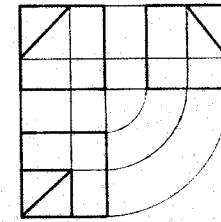

1º diedro

3º diedro

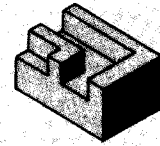
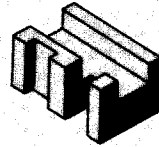
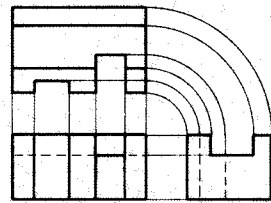
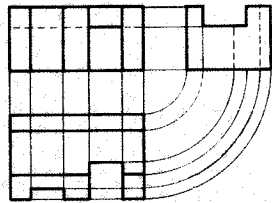

1º diedro

3º diedro

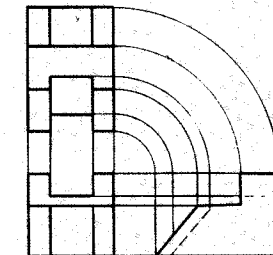
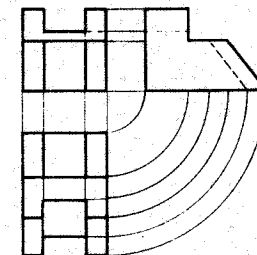
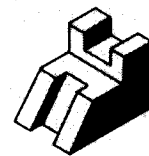
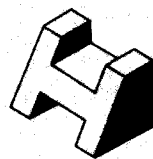
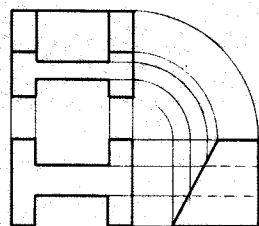
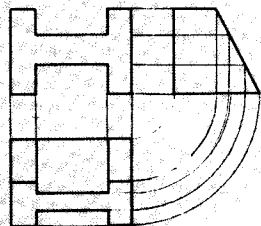
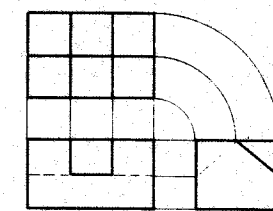
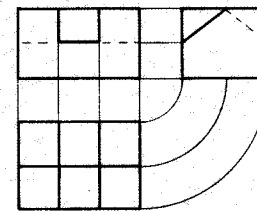
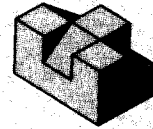
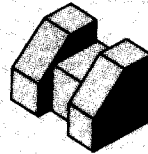
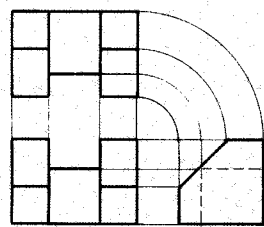
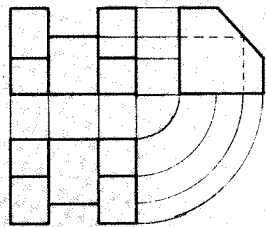
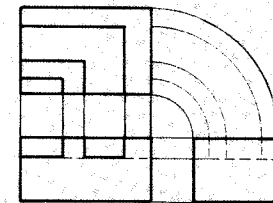
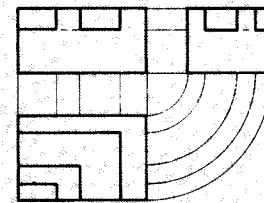

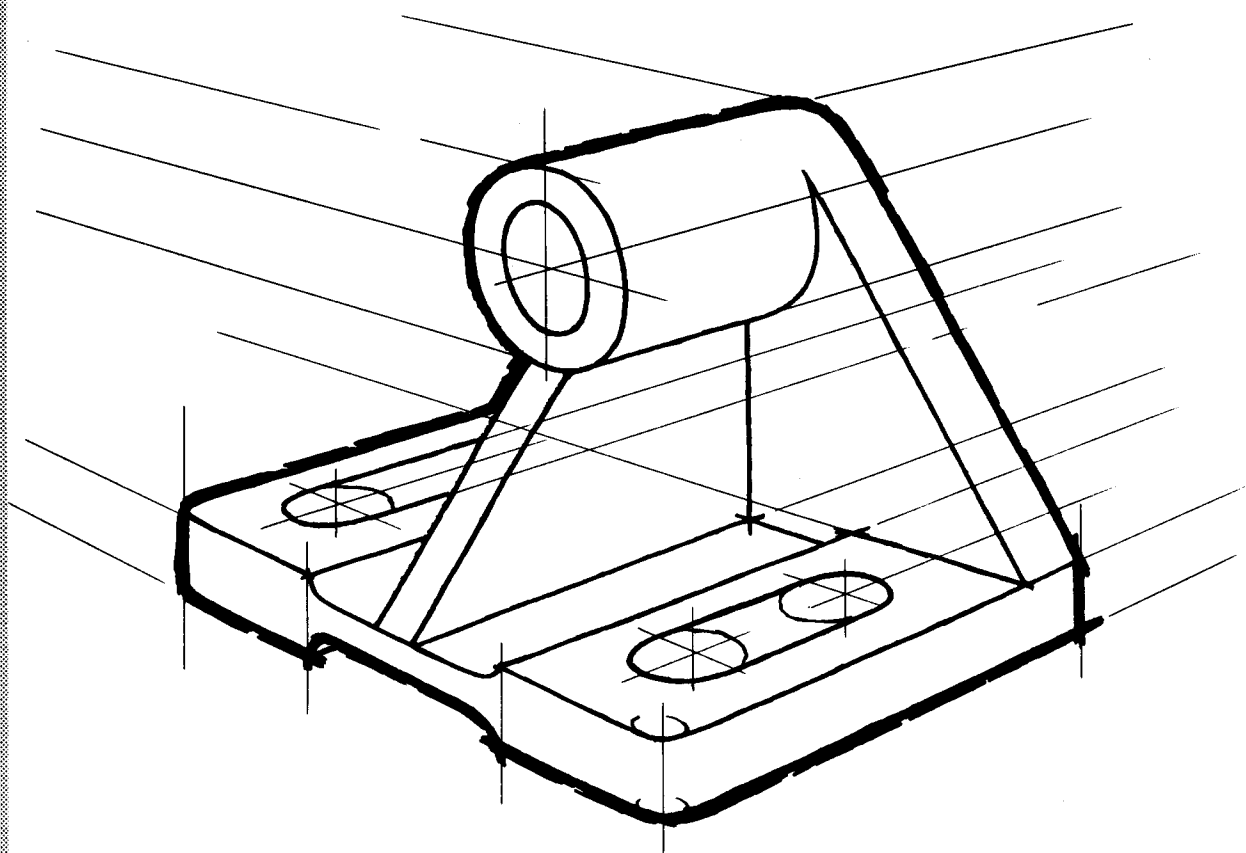

4

perspectiva

exata

cavaleira

bimétrica

isométrica



PERSPECTIVA EXATA

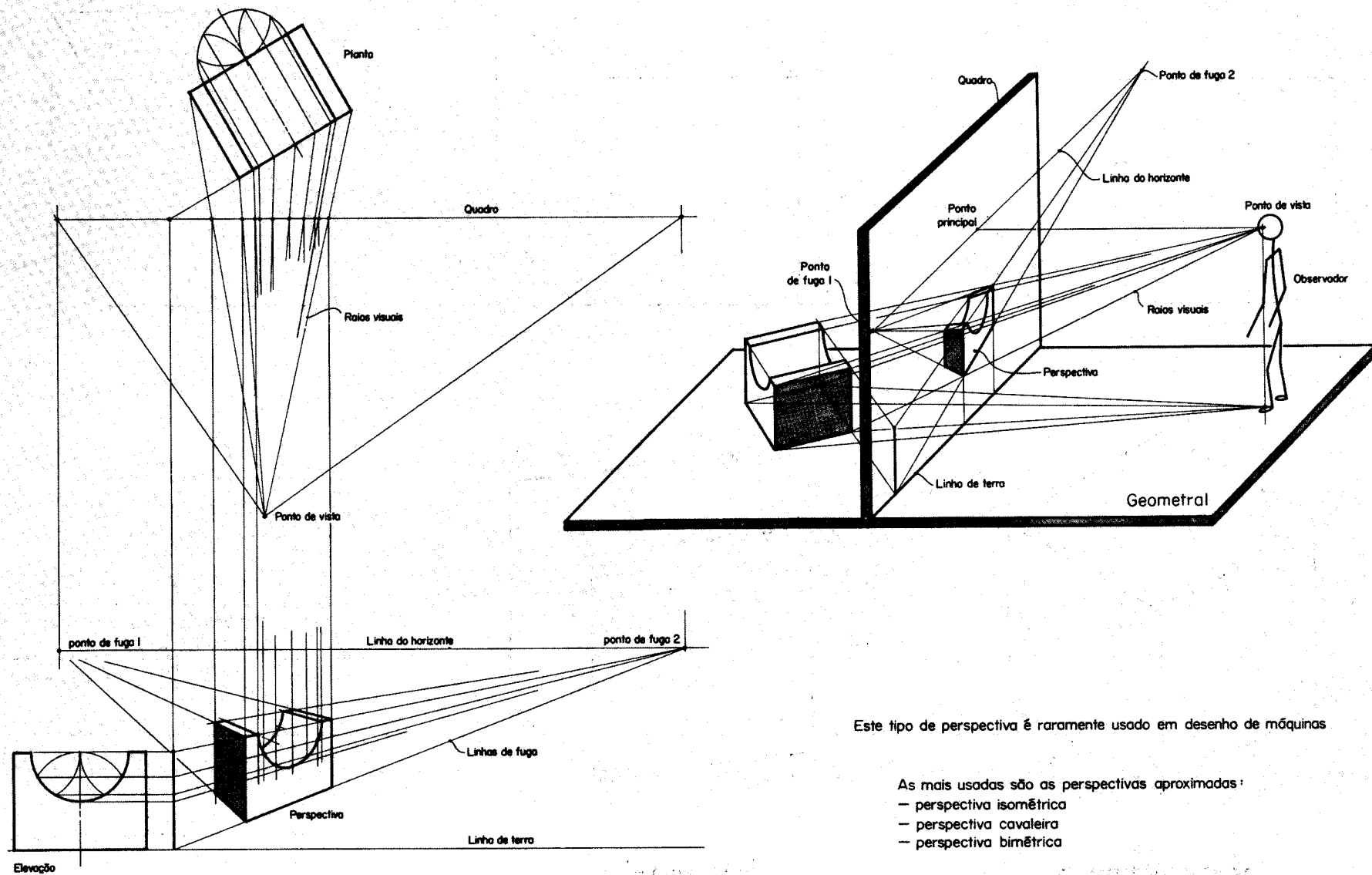

Este tipo de perspectiva é raramente usado em desenho de máquinas

- As mais usadas são as perspectivas aproximadas:
- perspectiva isométrica
 - perspectiva cavaleira
 - perspectiva bimétrica

cavaleira à 30°

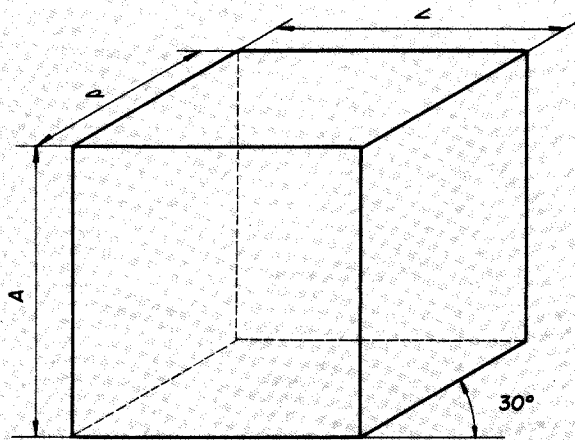

cavaleira à 45°

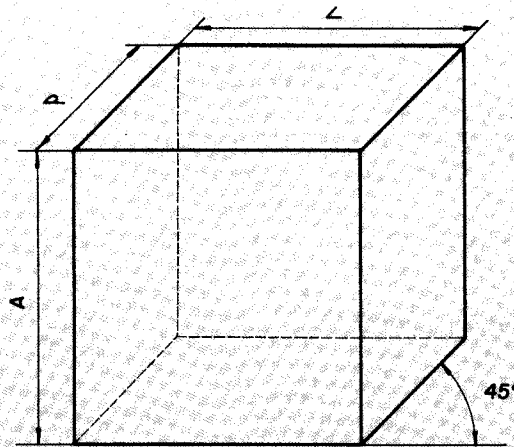

cavaleira à 60°

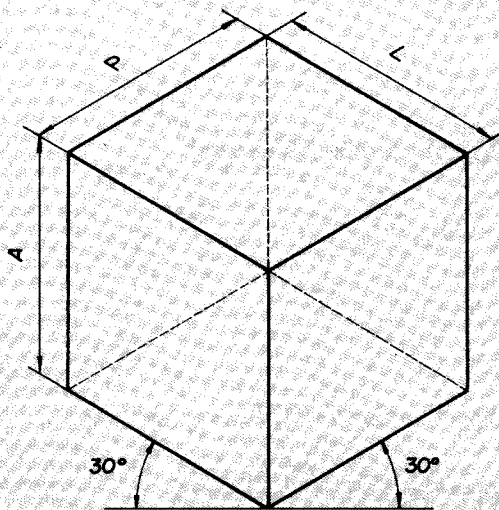
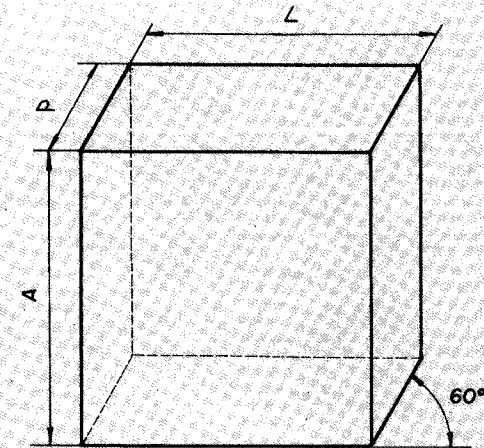

isométrica

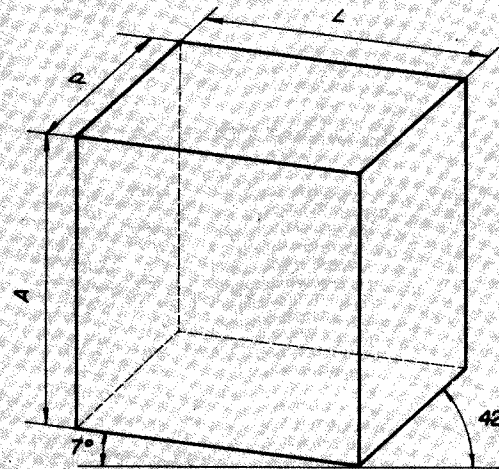

bimétrica

RELAÇÃO DAS MEDIDAS REAIS COM AS DO DESENHO					
PERSPEC.	CAVALEIRA			ISOMÉT.	BIMÉT.
	30°	45°	60°		
LARGURA	1:1	1:1	1:1	1:4/5	1:1
ALTURA	1:1	1:1	1:1	1:4/5	1:1
PROFUND.	1:2/3	1:1/2	1:1/3	1:4/5	1:1/2

As medidas devem ser demarcadas sempre nos planos de referências (horizontais e verticais)

PERSPECTIVA DE CIRCUNFERÊNCIAS

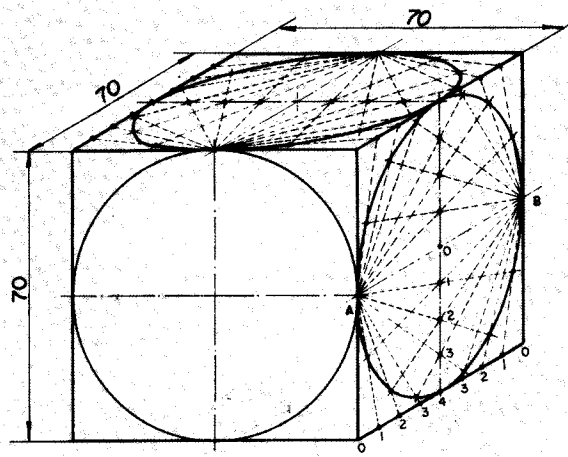

CAVALEIRA A 30°

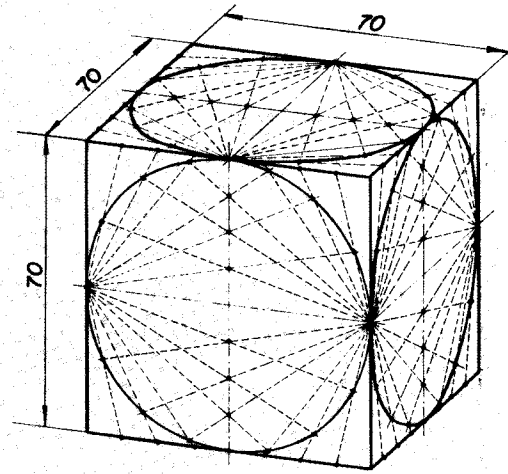

BIMÉTRICA

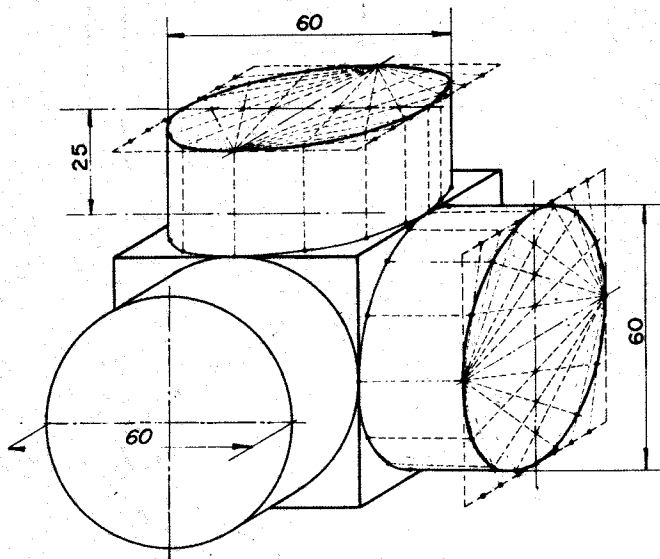

CAVALEIRA A 30°

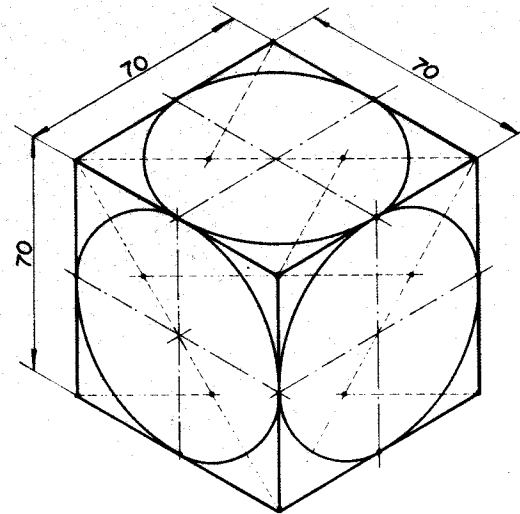

ISOMÉTRICA

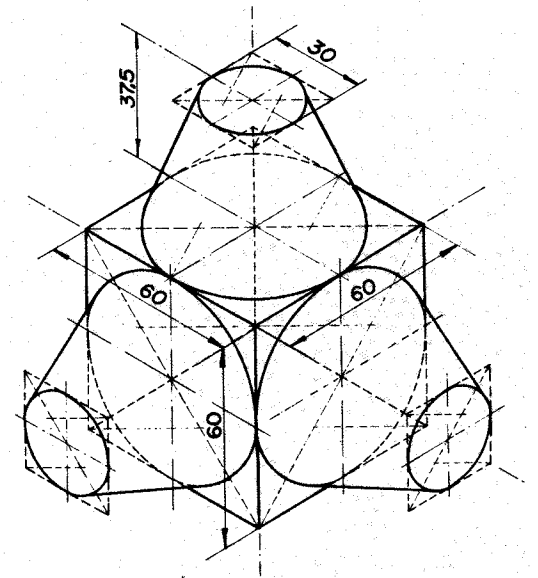

ISOMÉTRICA

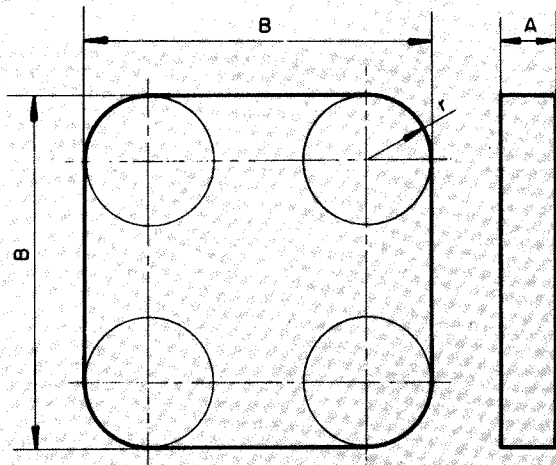

1ª etapa

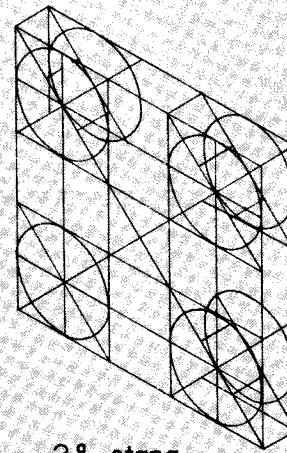
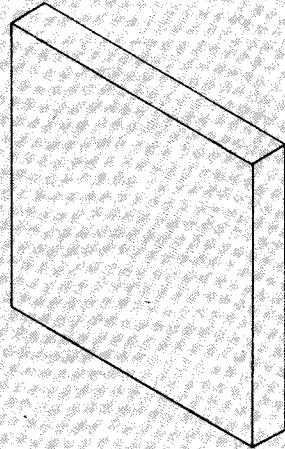

2ª etapa

3ª etapa

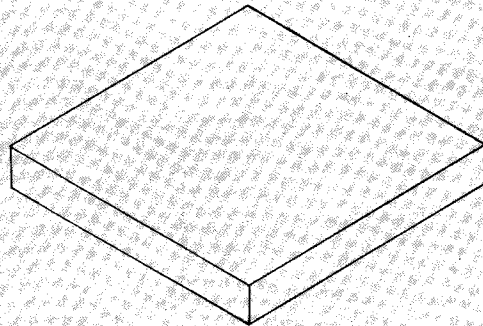
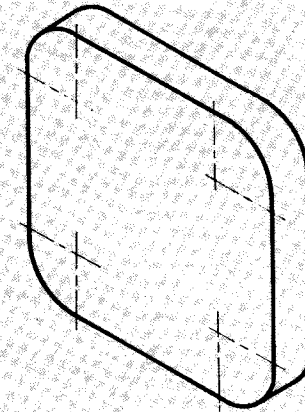

1ª etapa

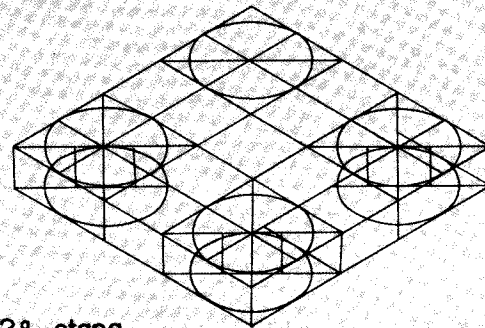

2ª etapa

3ª etapa

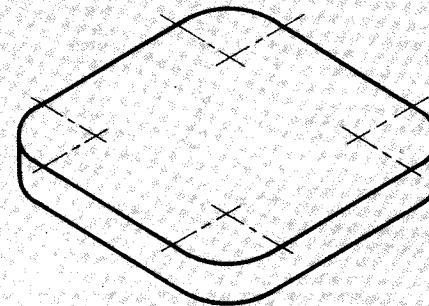

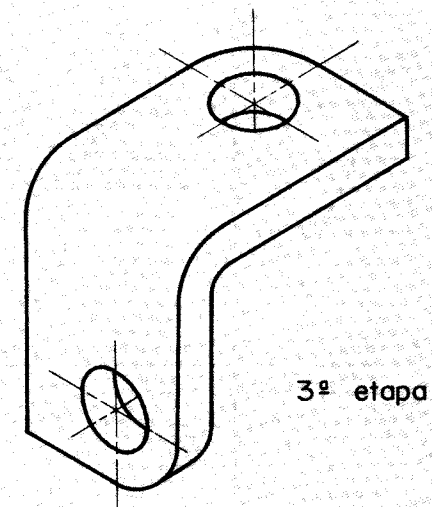
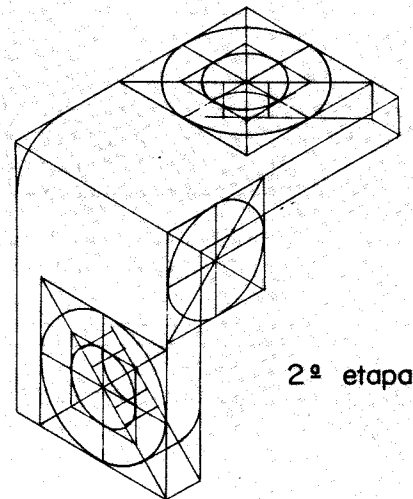
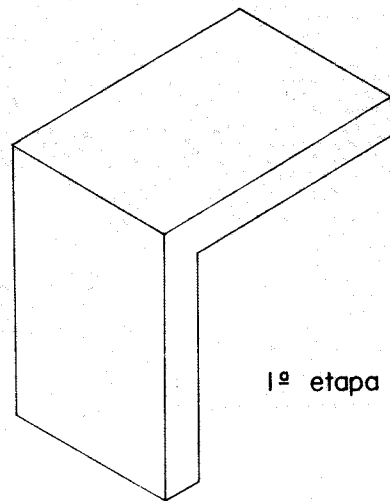
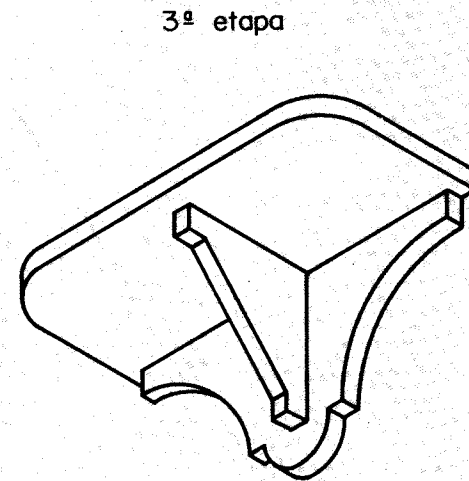
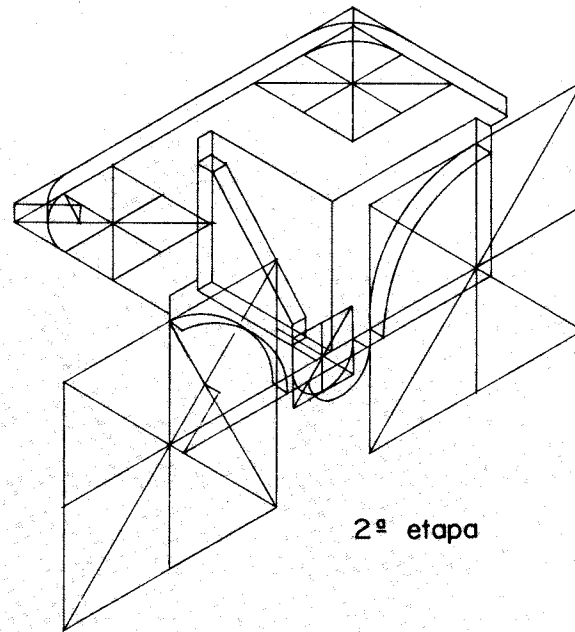
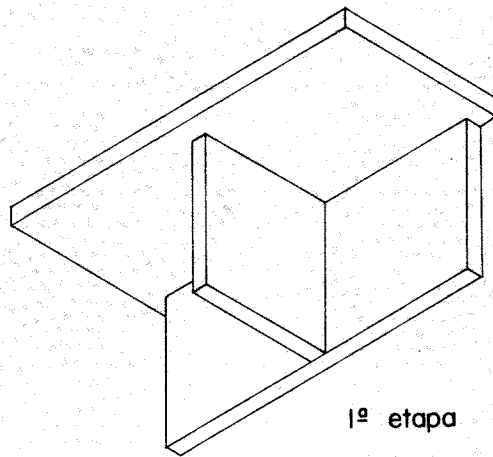

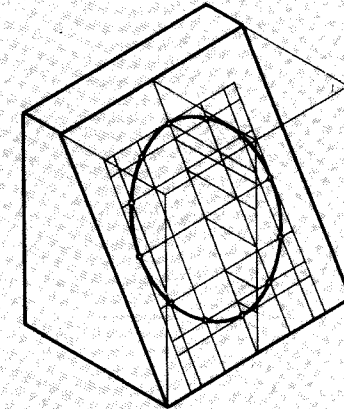
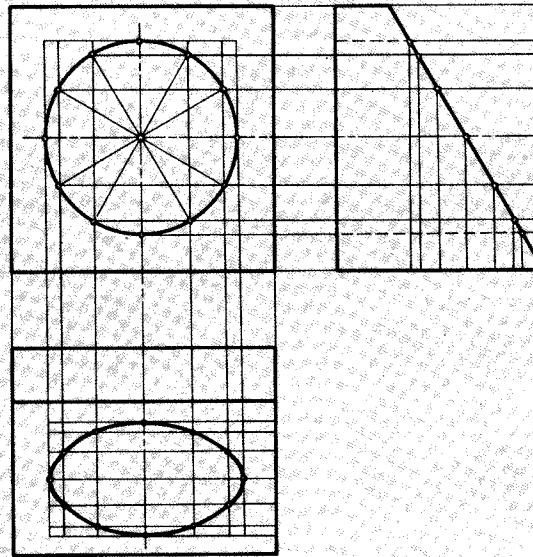
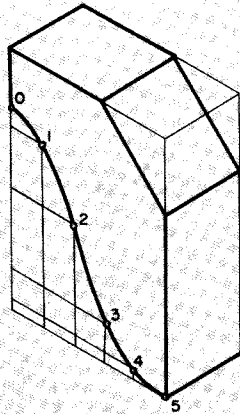
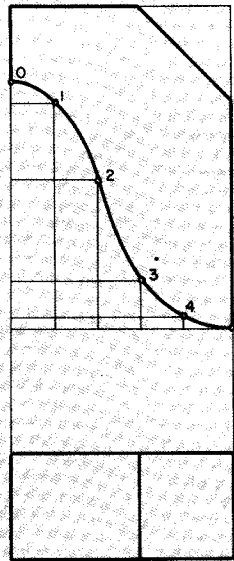
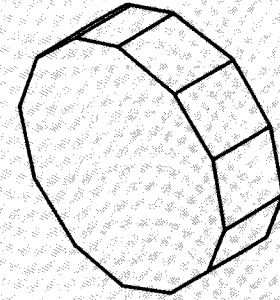
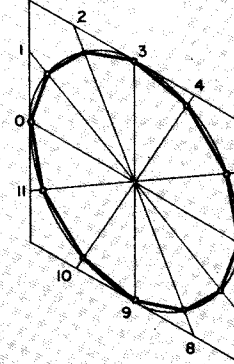
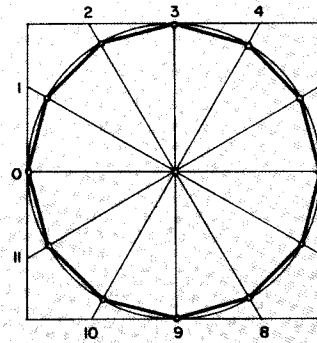
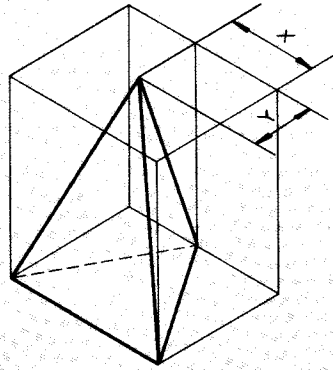
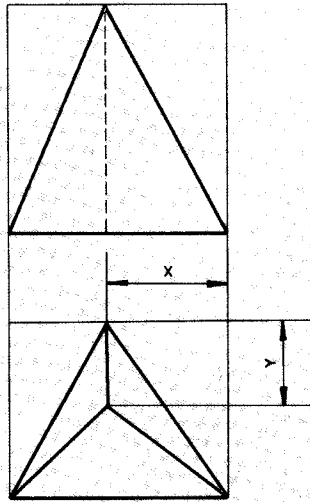

ESCOLHA DA PERSPECTIVA

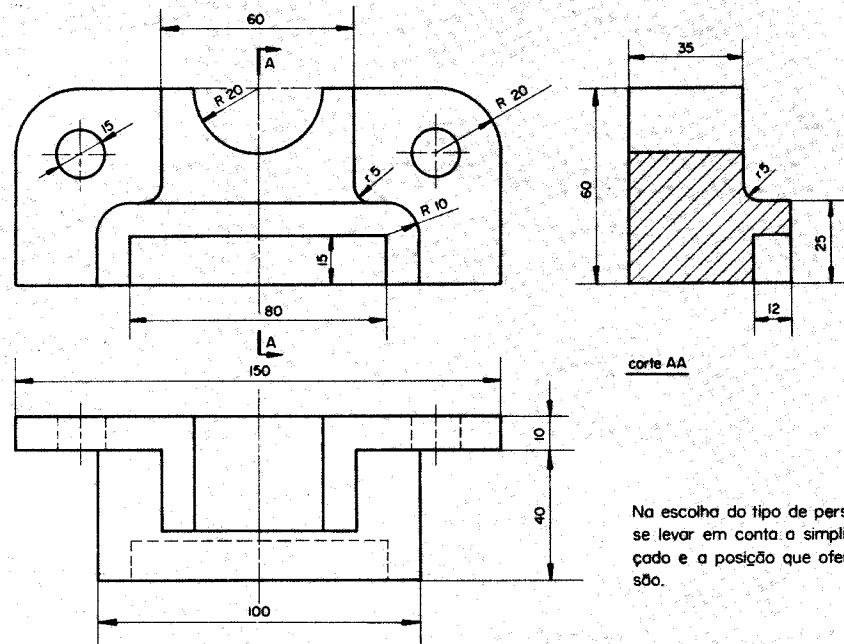

corte AA

Na escolha do tipo de perspectiva deve-se levar em conta a simplicidade no traçado e a posição que oferece melhor visão.

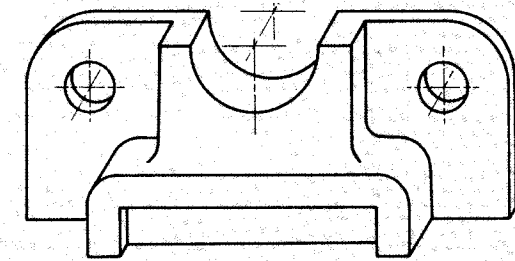

Solução fácil, porém, pouco expressiva.

cavaleira à 60°

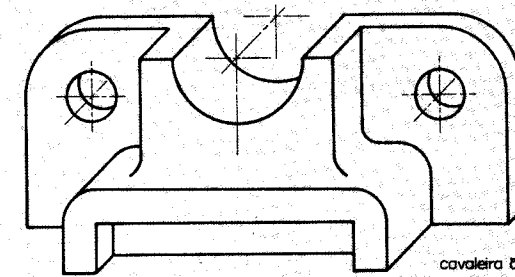

Solução fácil e bastante expressiva.

cavaleira à 45°

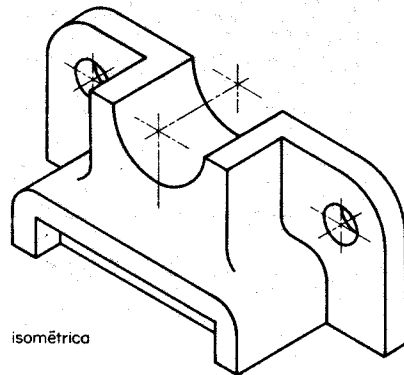

isométrica

Solução mais ou menos trabalhosa, porém, muito expressiva.

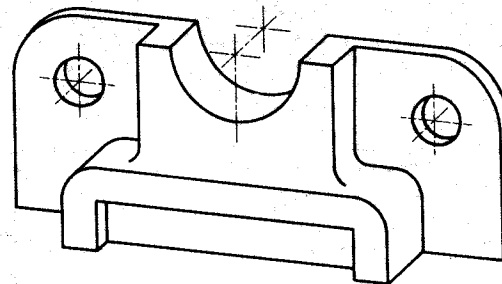

bimétrica

Solução muito trabalhosa e não expressiva.

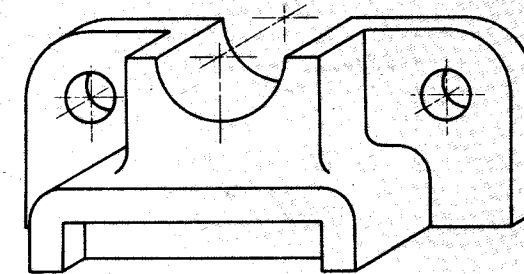

cavaleira à 30°

Solução fácil e mais ou menos expressiva.

ESCOLHA DA POSIÇÃO

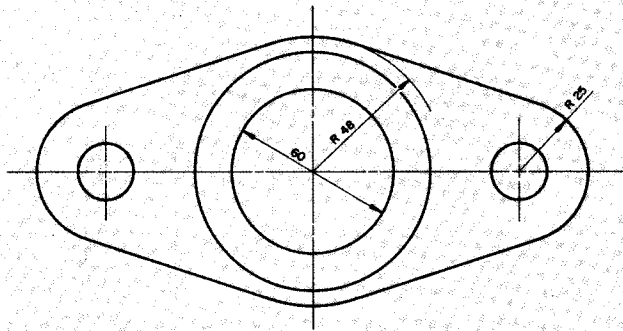
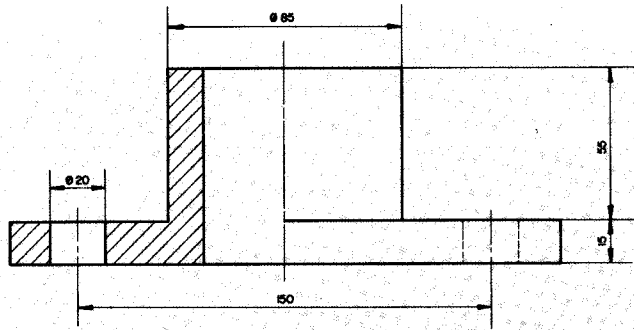

Os objetos devem ser representados nas posições que melhor os caracterizam.

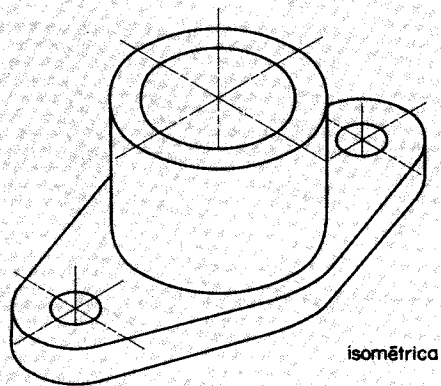

isométrica

MELHOR SOLUÇÃO (simples e expressiva)

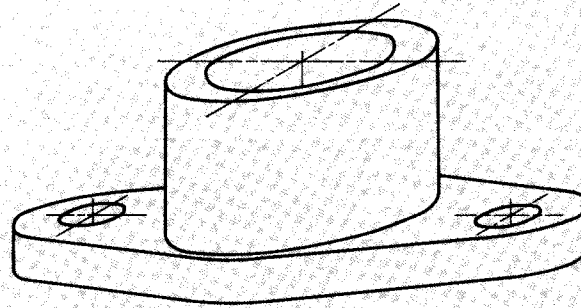

cavaleira à 30°

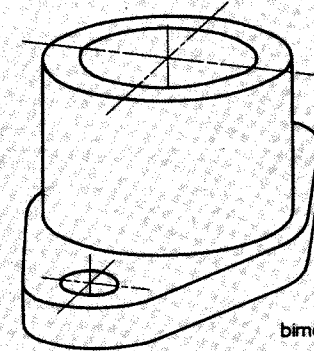

bimétrica

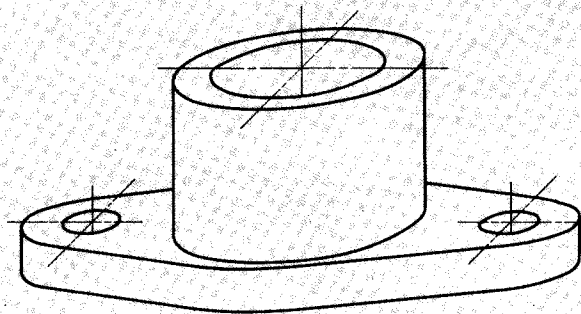

cavaleira à 45°

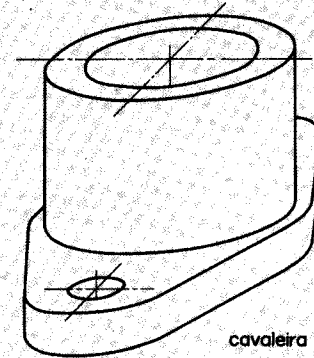

cavaleira à 45°

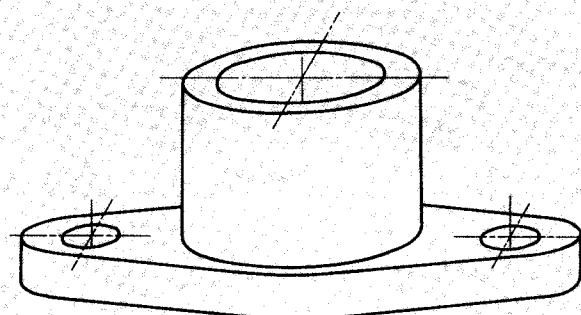

cavaleira à 60°

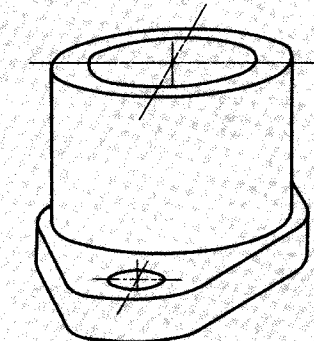

cavaleira à 60°

SOLUÇÕES NÃO RECOMENDÁVEIS (trabalhosas e com efeito de distorção)

SEQUÊNCIA DO TRAÇADO

1º Escolher a perspectiva e a posição.

2º Estabelecer a escala.

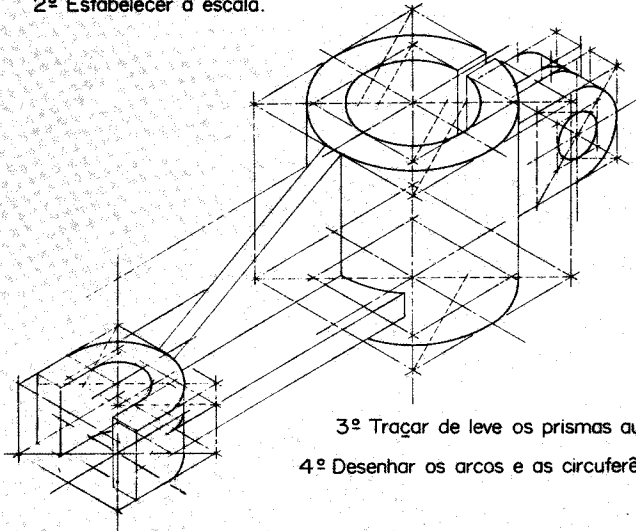

3º Traçar de leve os prismas auxiliares.

4º Desenhar os arcos e as circunferências.

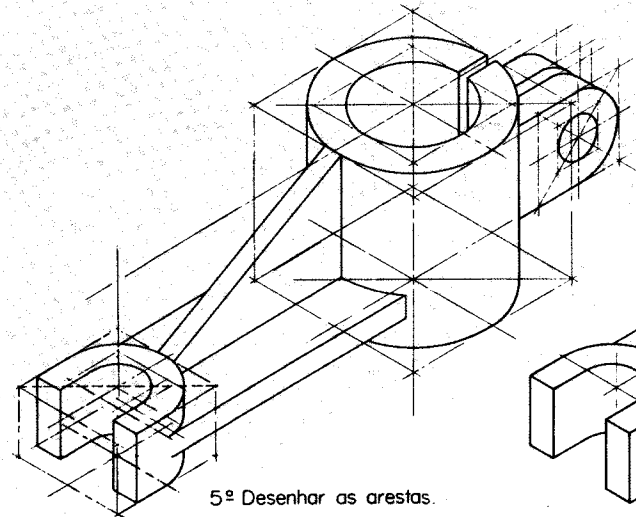

5º Desenhar as arestas.

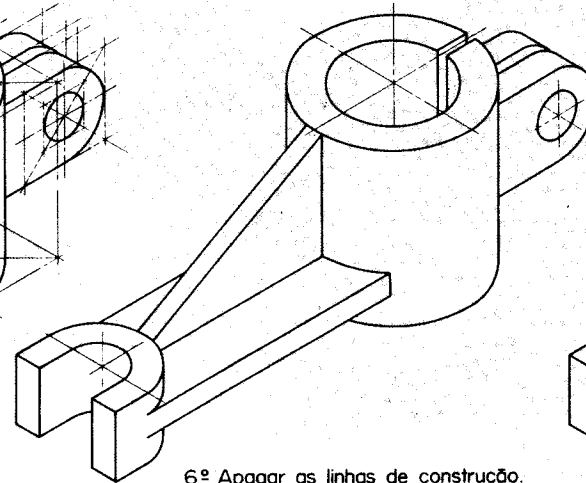

6º Apagar as linhas de construção.

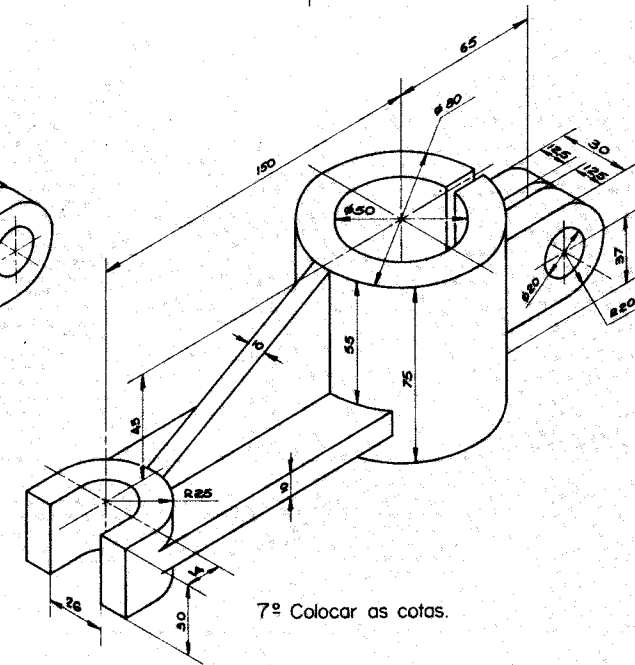

7º Colocar as cotas.

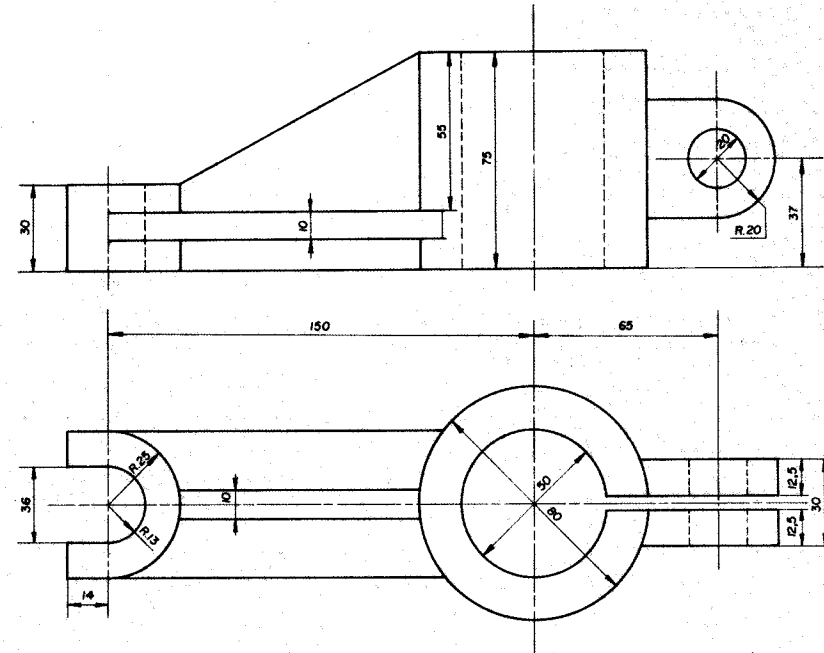

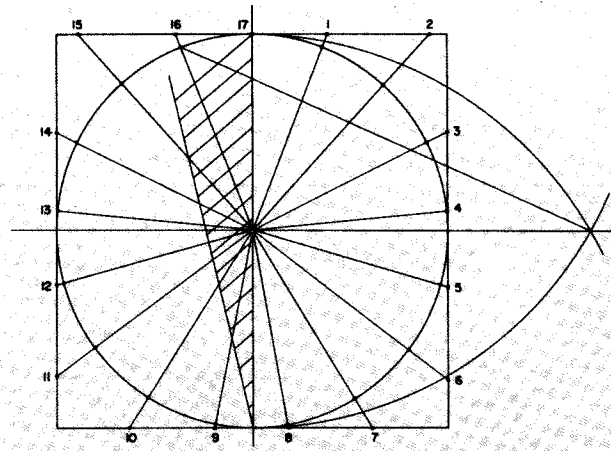
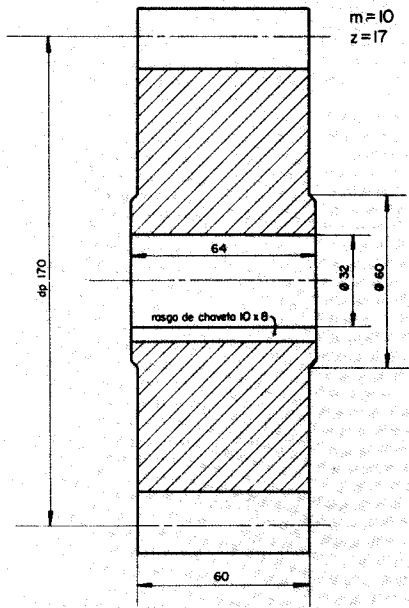

1ª Etapa

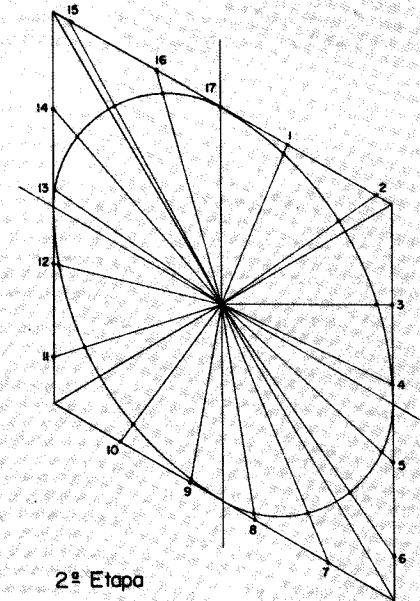

2ª Etapa

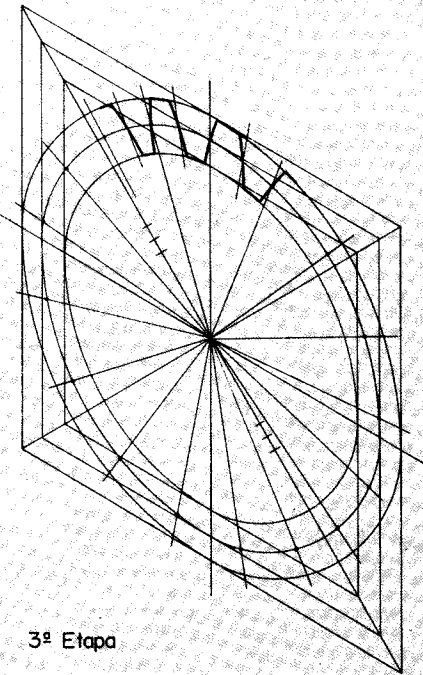

3ª Etapa

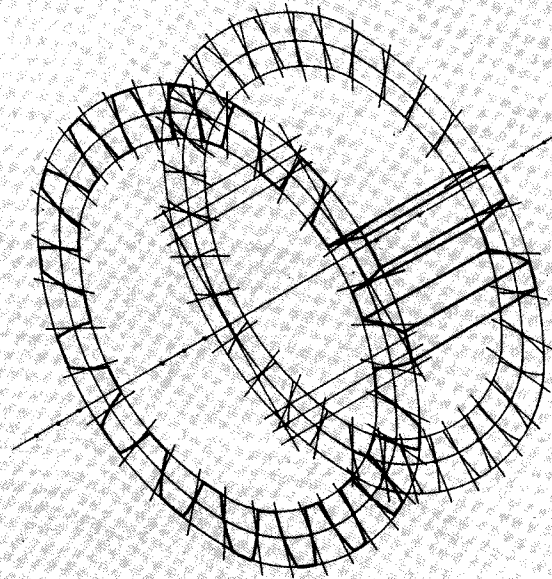

4ª Etapa

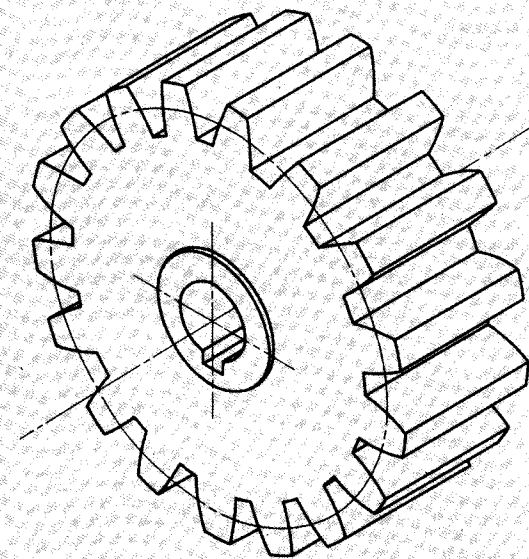

Etapa final

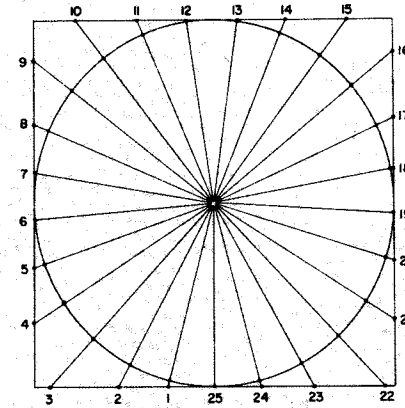
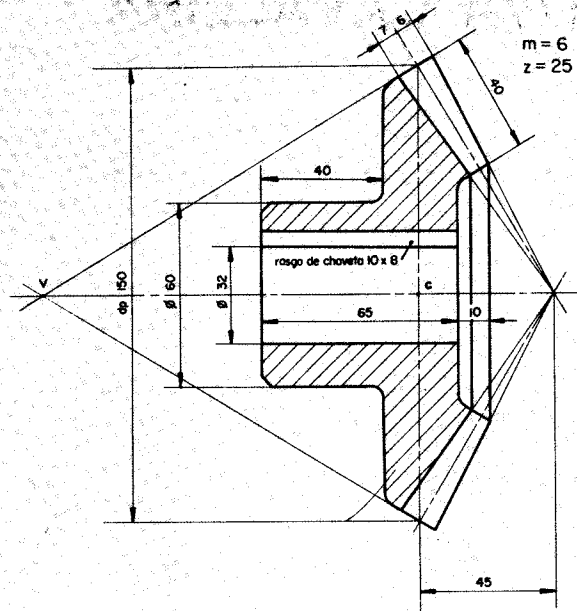

1ª Etapa

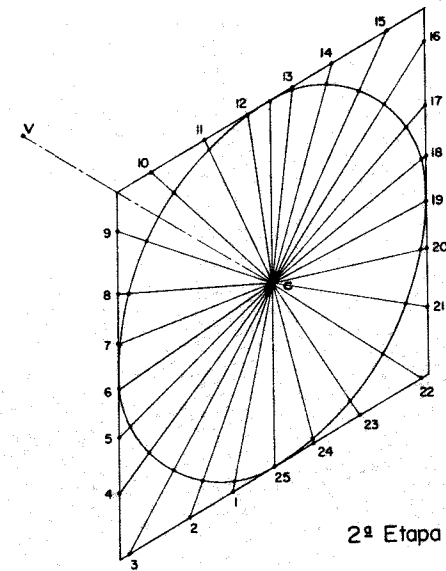

2ª Etapa

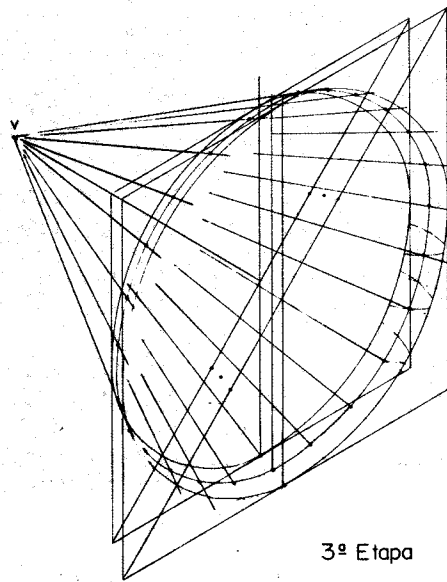

3ª Etapa

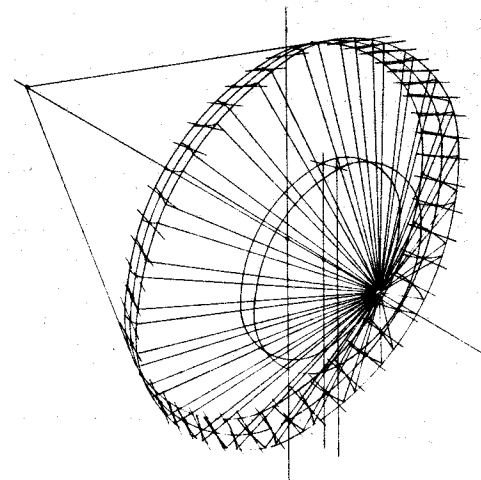

4ª Etapa

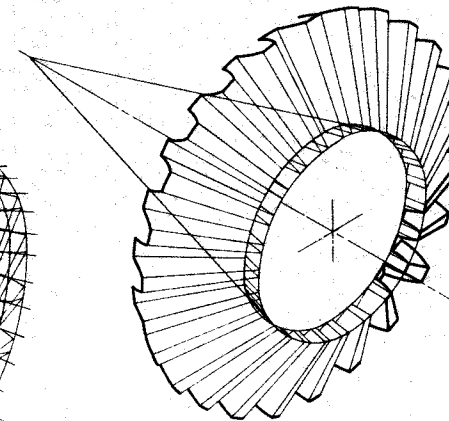

5ª Etapa

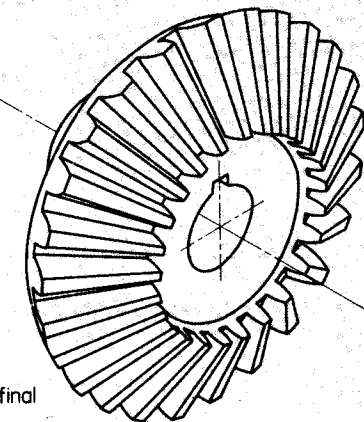

Etapa final

PERSPECTIVA CAVALEIRA

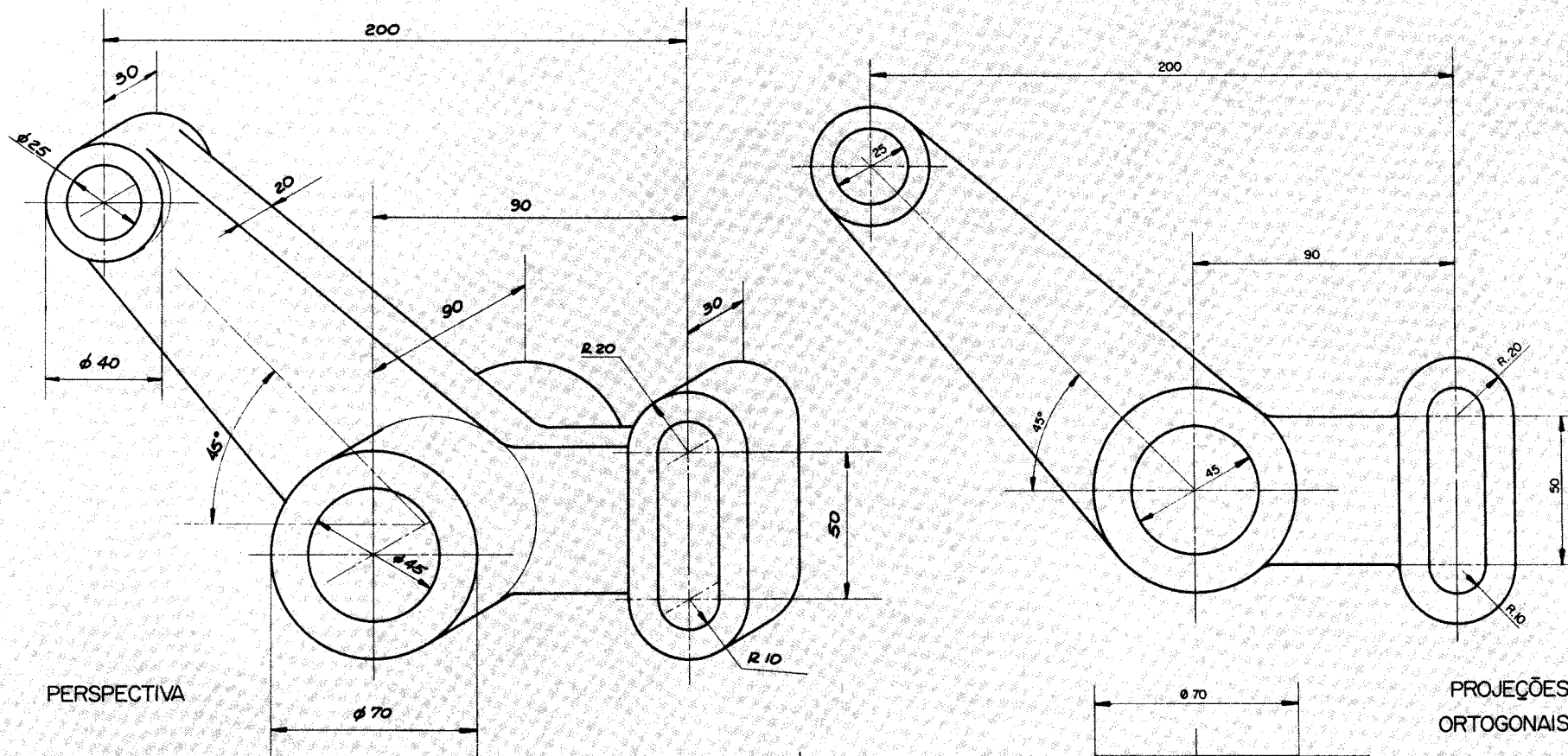

PERSPECTIVA

PROJEÇÕES ORTOGONAIS

Usando-se as escalas indicadas obtêm-se um bom efeito dimensional entre a perspectiva e as projeções ortogonais. Considerando-se estas escalas, pode-se passar reciprocamente de uma representação para outra.

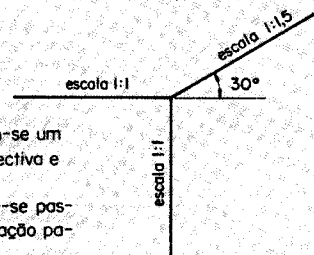

PERSPECTIVA ISOMÉTRICA

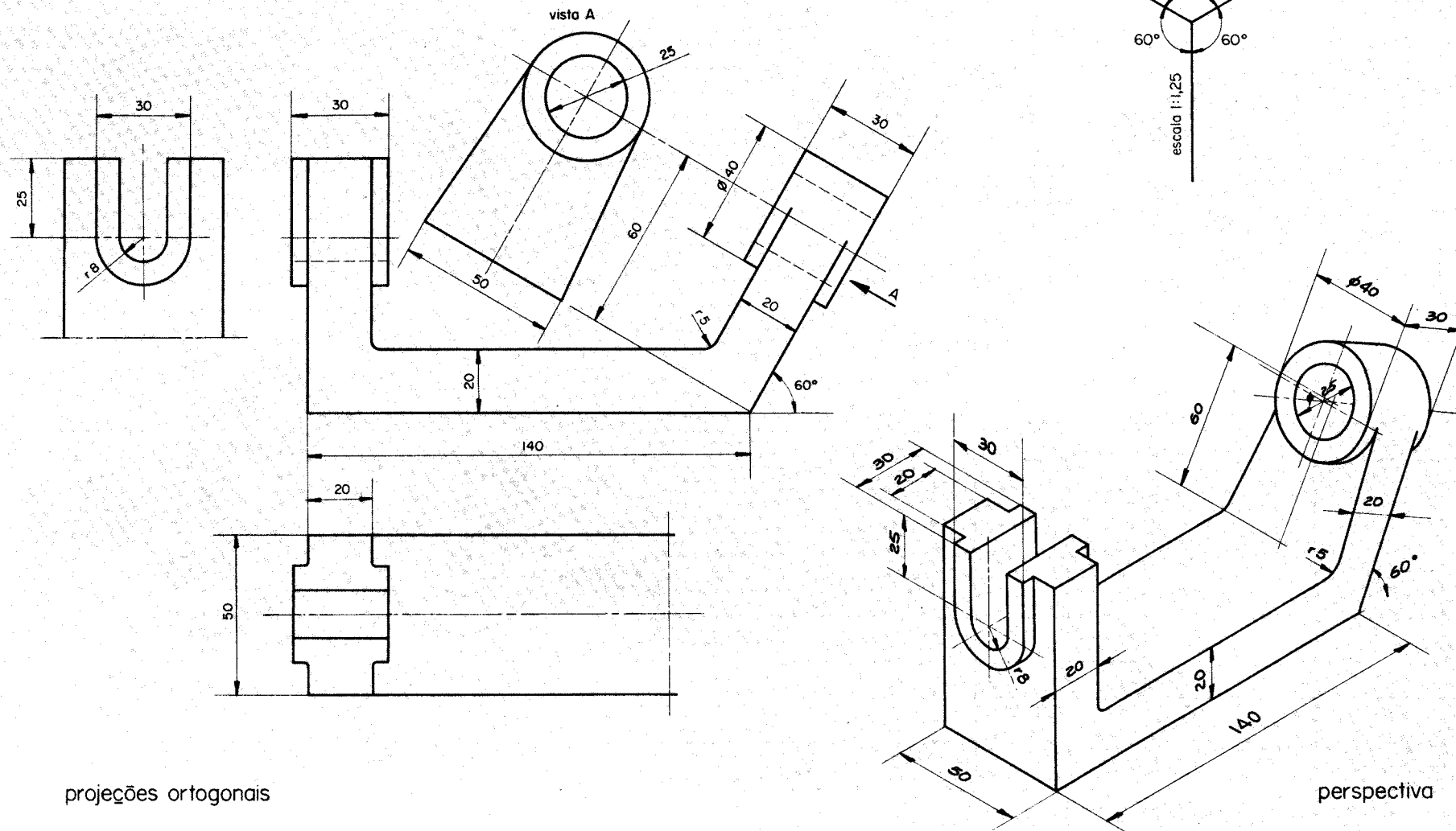

projeções ortogonais

perspectiva

PERSPECTIVA BIMÉTRICA

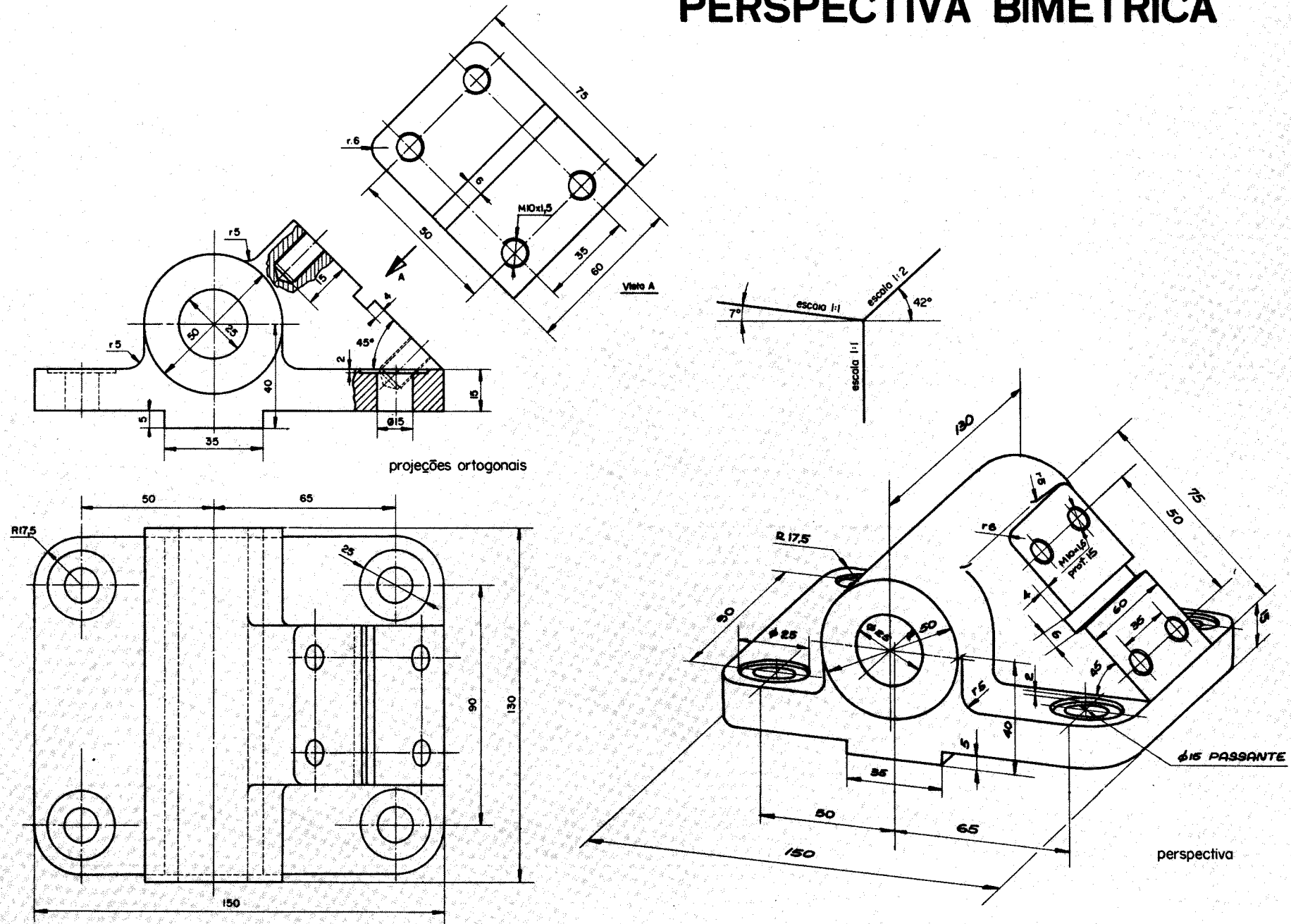

EXEMPLOS

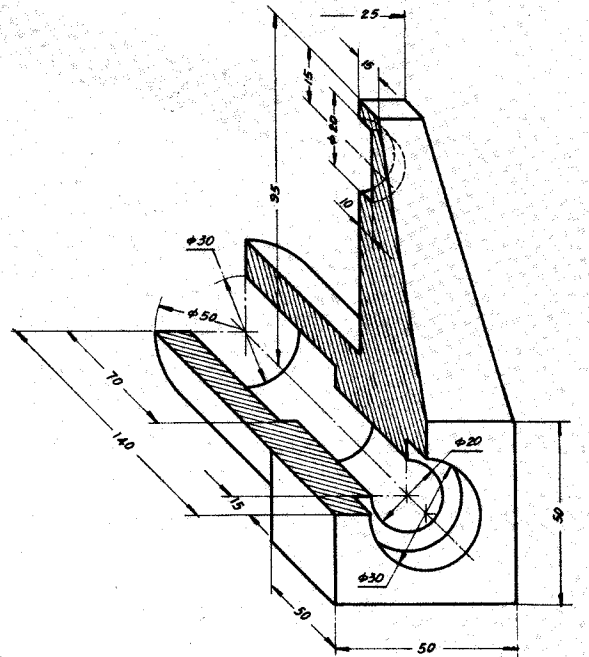
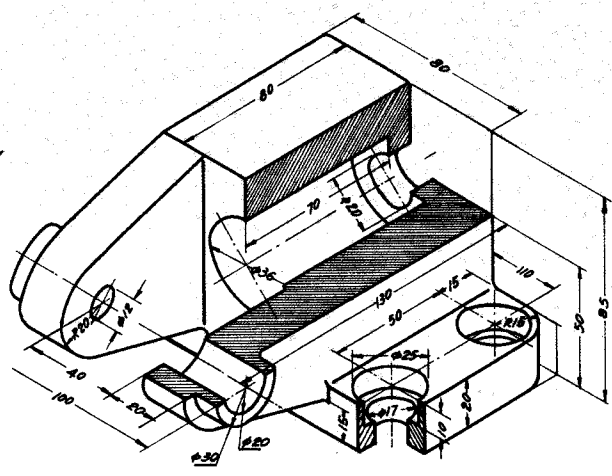
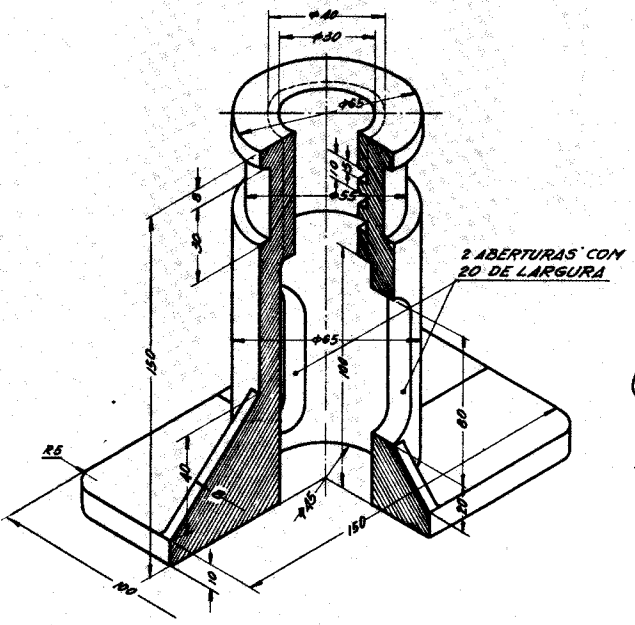
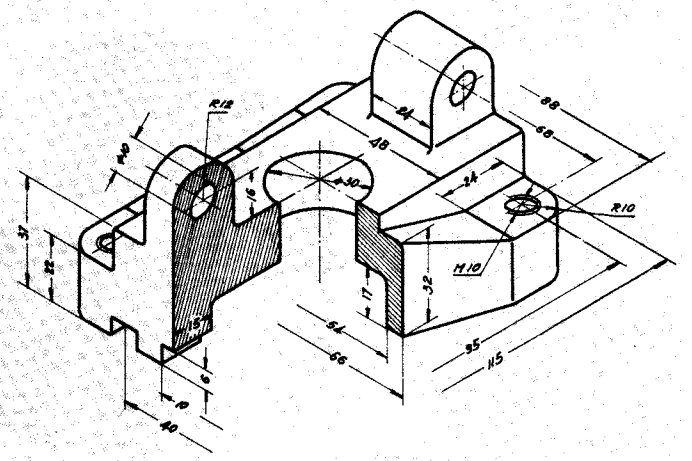
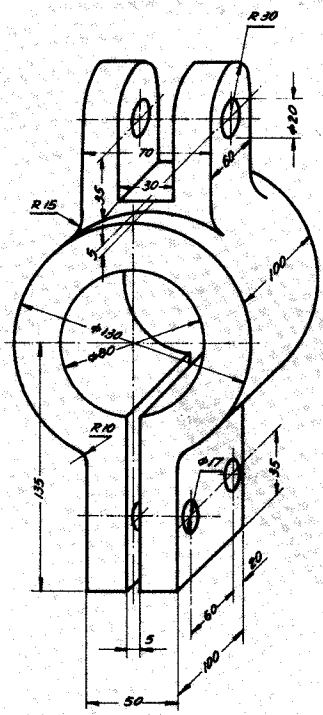
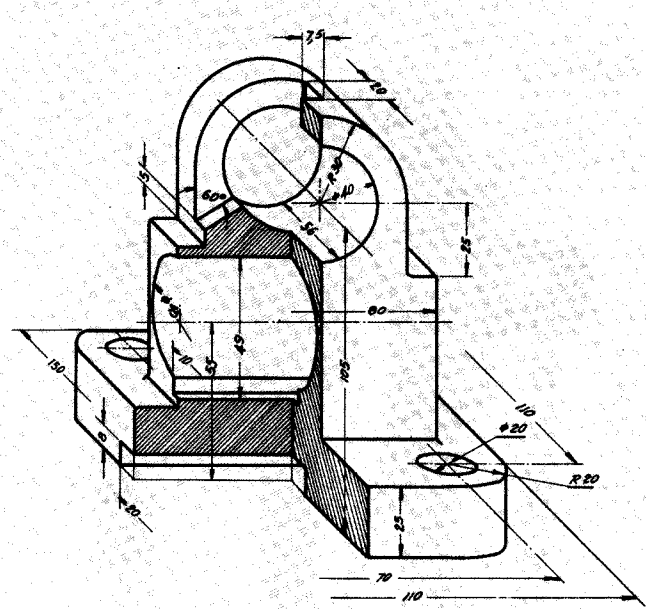

PERSPECTIVA SOMBREADA

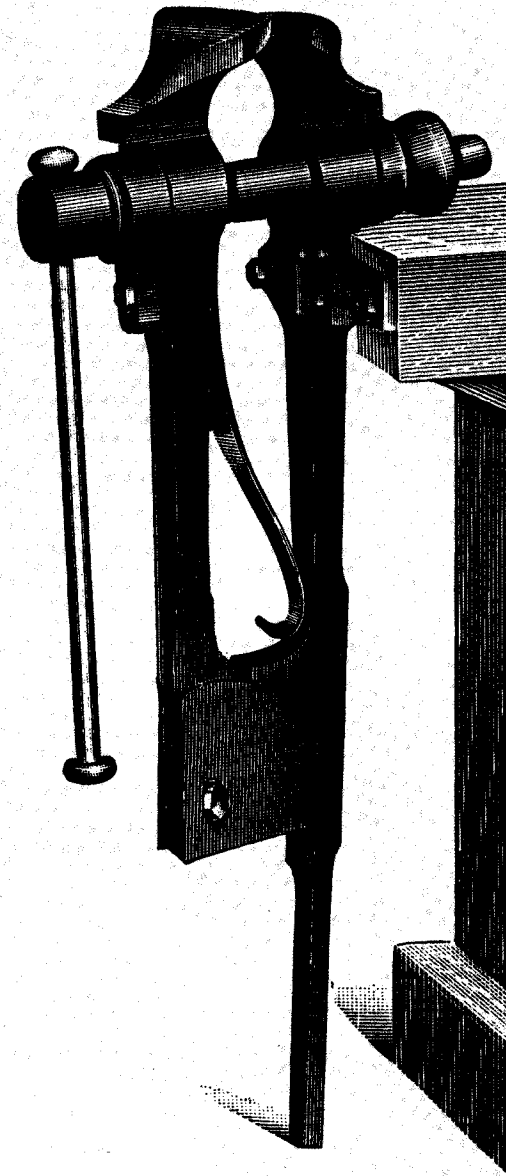
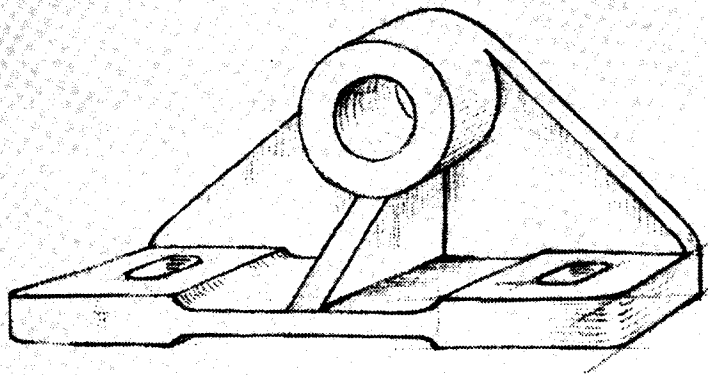
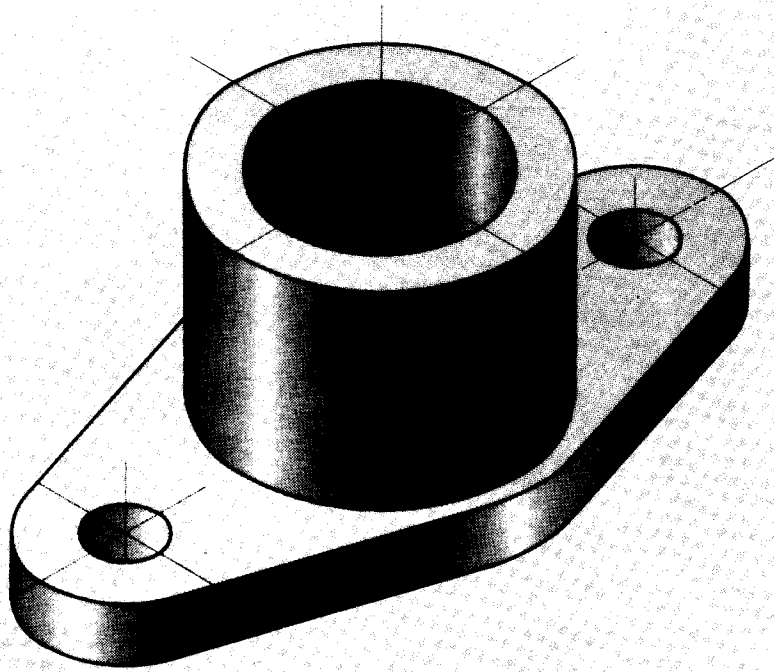

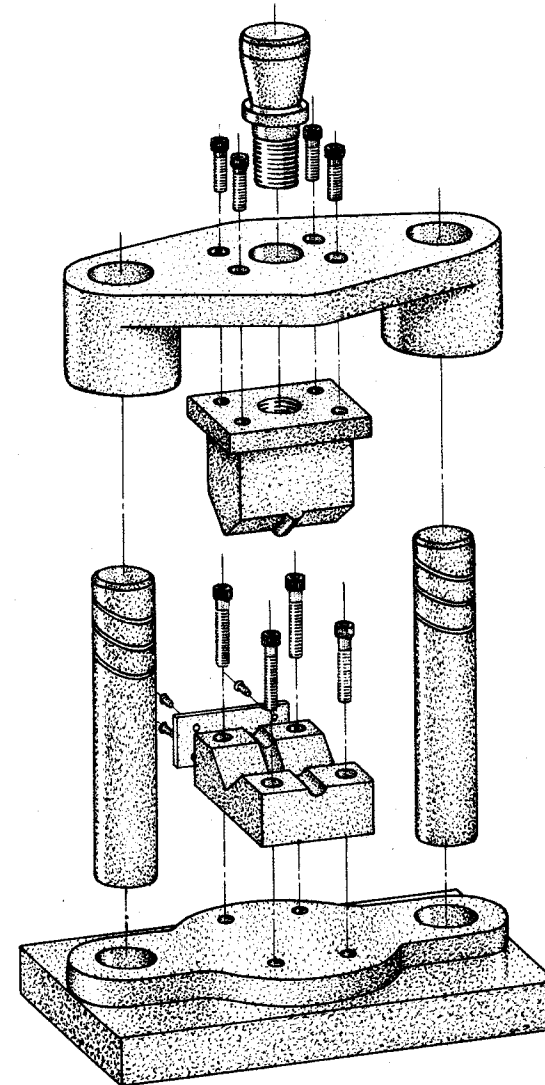
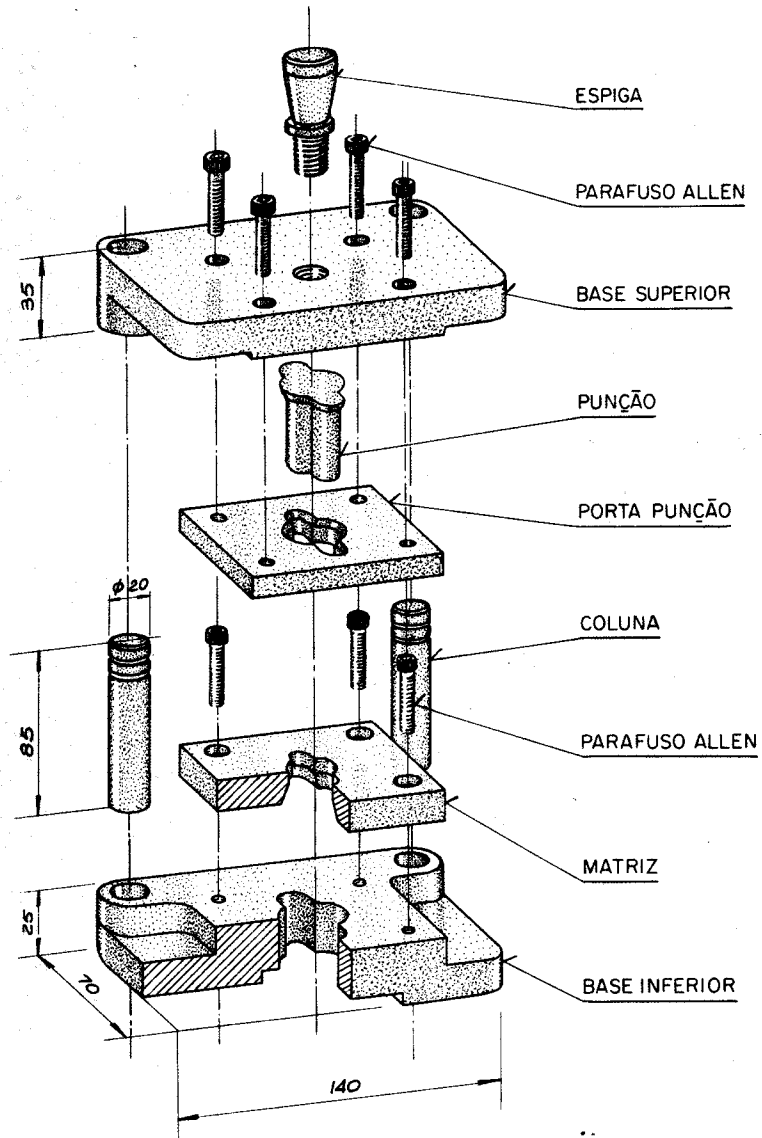

CROQUIS EM PERSPECTIVA ISOMÉTRICA

Papel isométrico

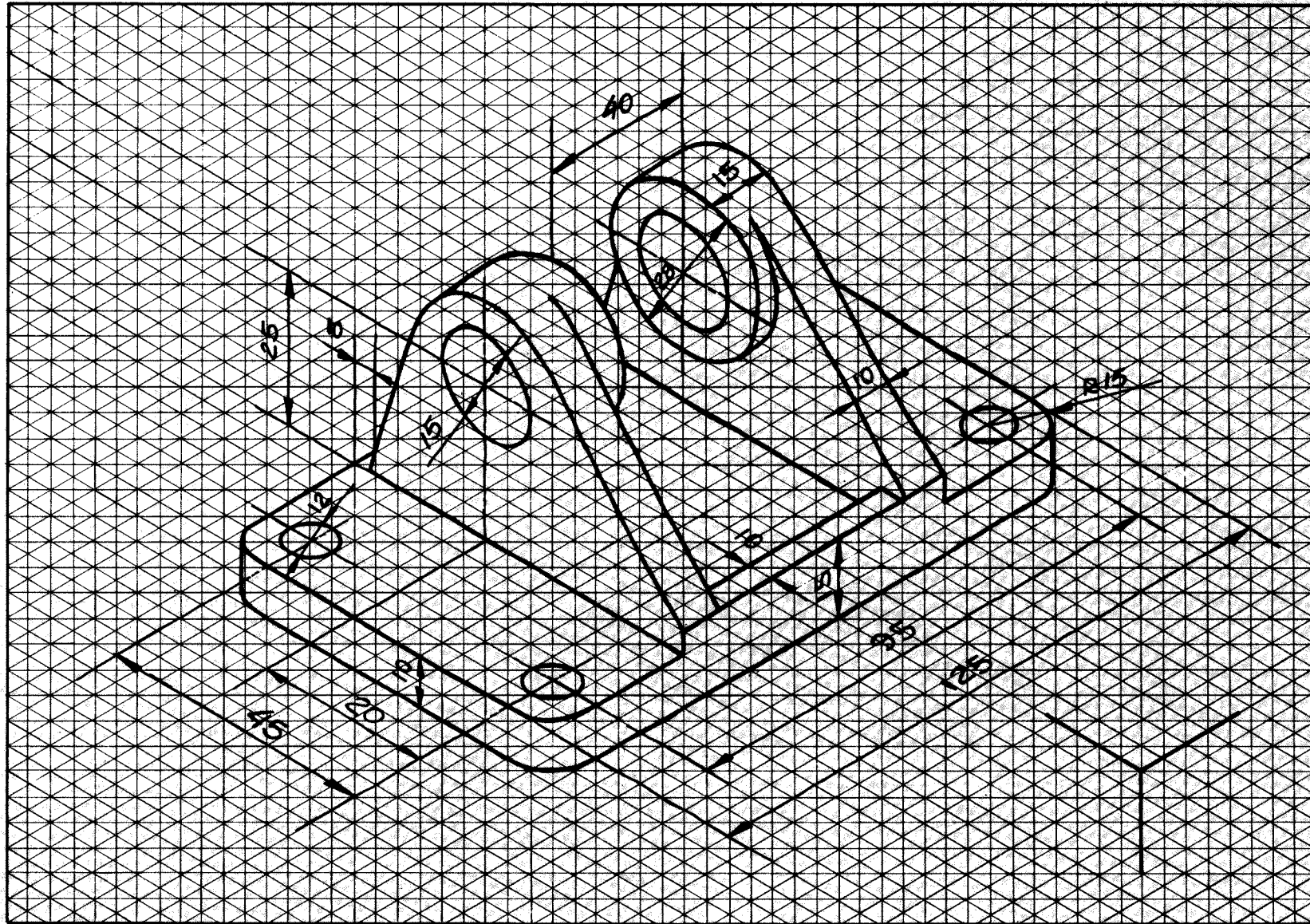

CROQUIS EM PERSPECTIVA CAVALEIRA

Papel isométrico

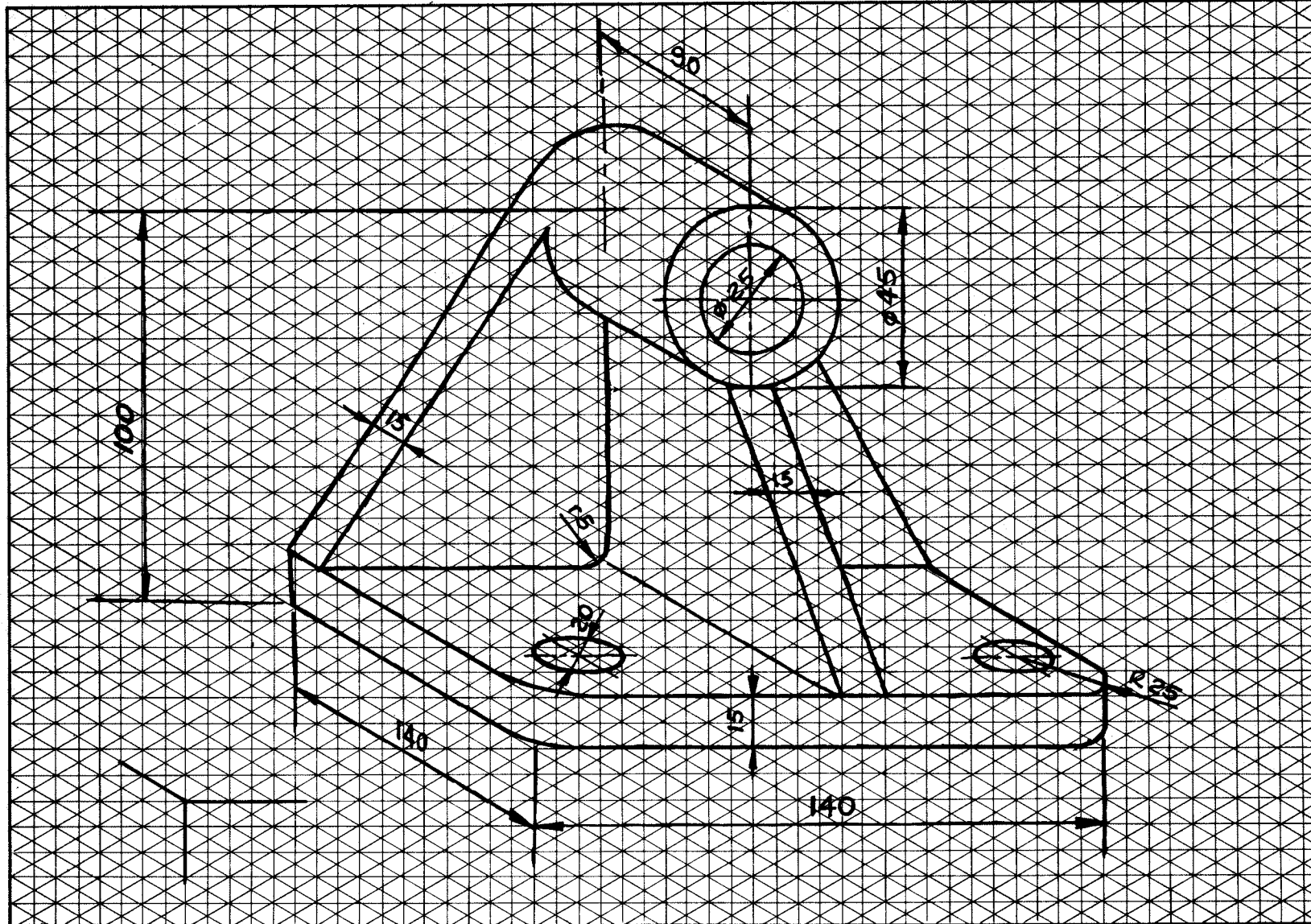



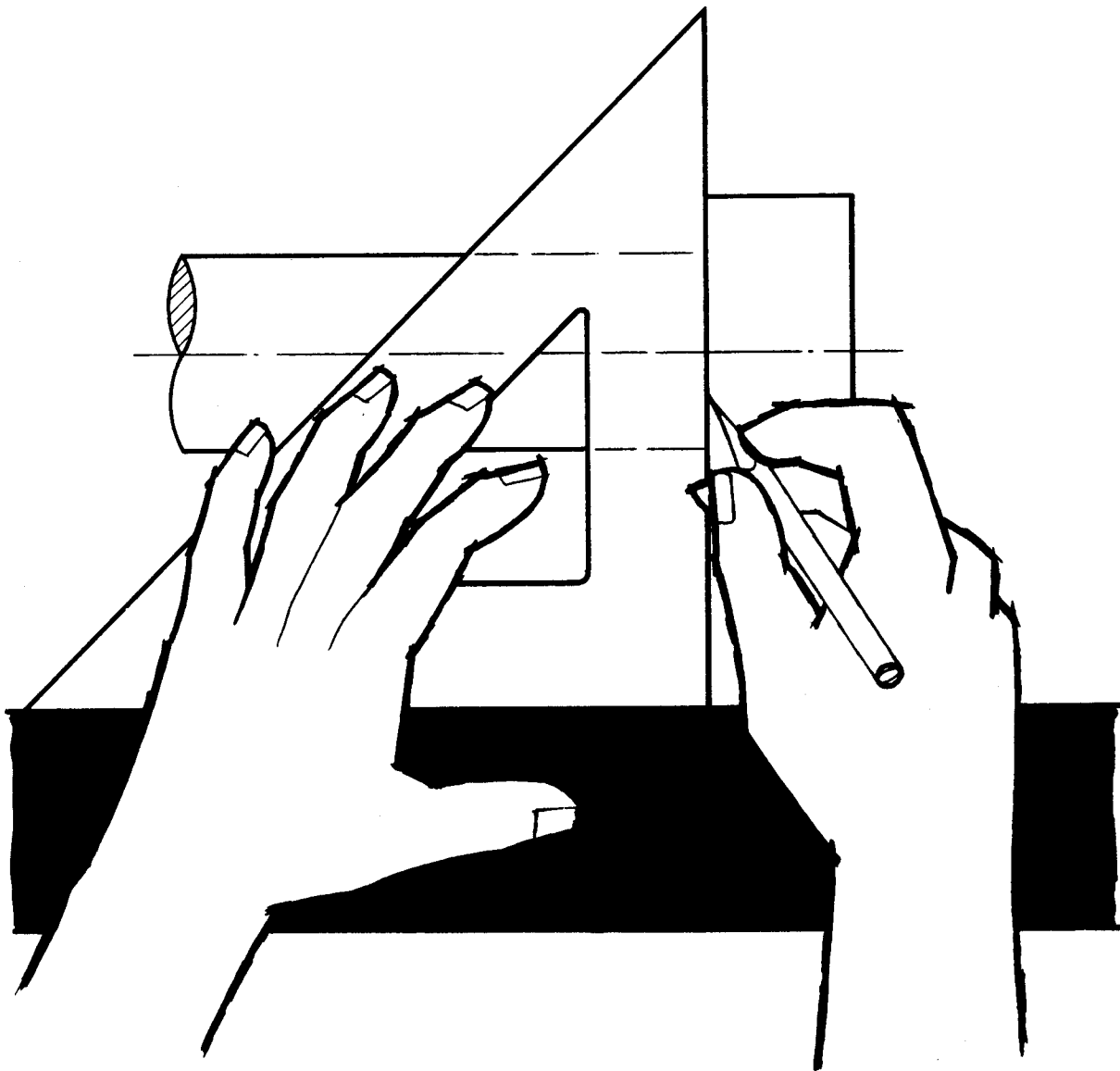

5 normas e convencões

formato de papel
dobramento da folha
letras e algarismos
linhas
escala
vistas
hachuras
cortes e secões
rupturas
representações simplificadas
e convencionais
símbolos
cotas
recomendações e conselhos

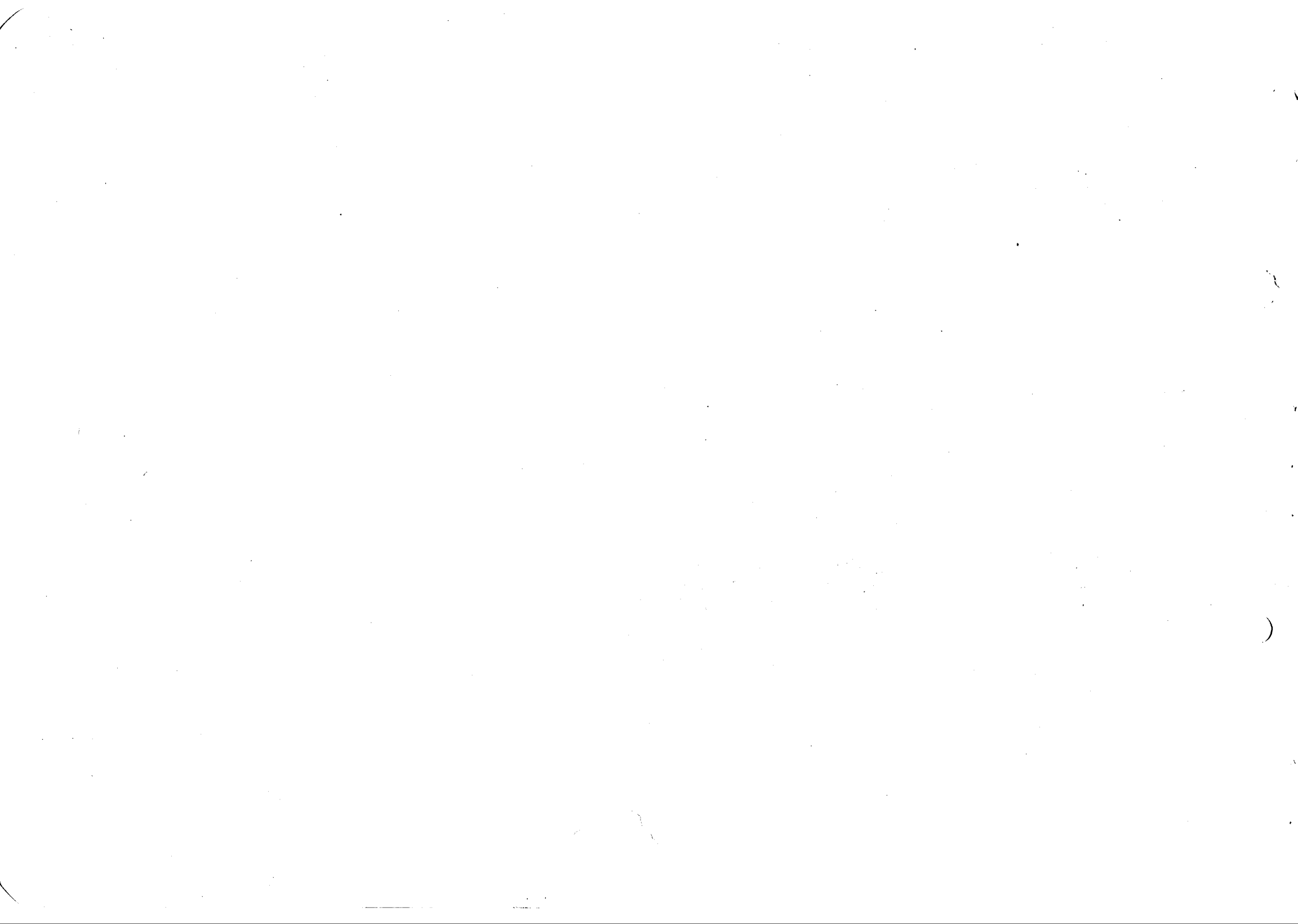

NORMAS E CONVENÇÕES

FORMATO DE PAPEL

1-Formato básico A₀ :

-Retângulo de 841 mm x 1189 mm com área de 1 m²

2-Formatos derivados do formato básico :

-Cada formato se obtém pela bipartição do anterior, segundo uma linha paralela ao menor lado do retângulo bipartido.

-Os formatos são geometricamente semelhantes entre si.

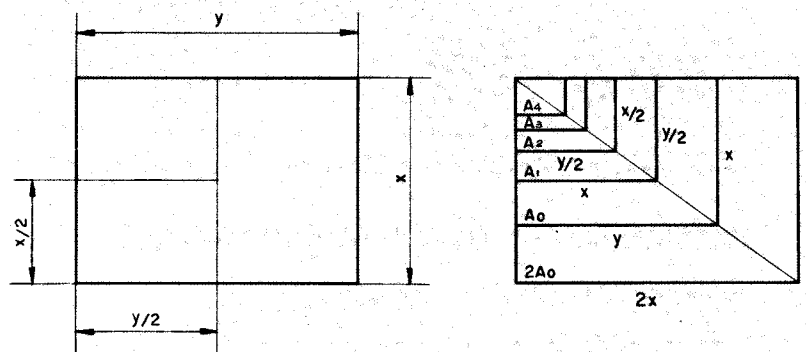

-Os lados de um formato qualquer guardam entre si a mesma razão que existe entre o lado de um quadrado e sua diagonal.

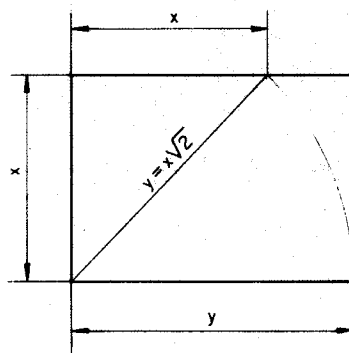

-As áreas dos formatos derivados são múltiplas ou submúltiplas da área do formato básico (1 m²).

-Cada formato é representado pelas dimensões de seus lados em milímetro ou pelo respectivo símbolo.

Ex.: 210 mm x 297 mm ou A4

3- Tabela

Formato Série A	Linha de corte mm	Margem "m" mm	Fôlha não cortada (medida mín.) mm
4 A ₀	1.682 x 2.378	20	1.720 x 2.420
2 A ₀	1.189 x 1.682	15	1.230 x 1.720
A ₀	841 x 1.189	10	880 x 1.230
A ₁	594 x 841	10	625 x 880
A ₂	420 x 594	10	450 x 625
A ₃	297 x 420	10	330 x 450
A ₄	210 x 297	5	240 x 330
A ₅	148 x 210	5	165 x 240
A ₆	105 x 148	5	120 x 165

4-Podem ser usados formatos compostos obtidos pela conjugação de formatos iguais ou consecutivos.

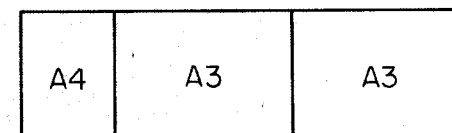

5-No lado vertical esquerdo, recomenda-se uma margem de 25 mm, no caso de arquivamento do desenho em classificadores.

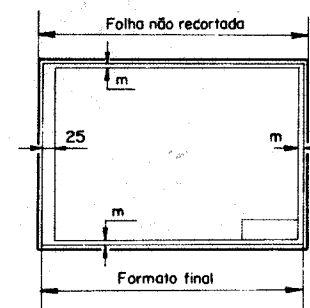

Formato segundo a ASA

Formato	Linha de corte pol.	Margem pol.
1	8-1/2 x 11	1/2
2	11 x 17	1/2
3	17 x 22	1/2
4	22 x 34	1/2
5	25-1/2 x 44	1/2
6	34 x 55	1/2

(American Standards Association)

DOBRAMENTO DA FOLHA

6 - Sendo necessário o dobramento de folhas, o formato final deve ser o A4 de modo a deixar visível e quadro destinado à legenda.

O dobramento das folhas pode ser efetuado da seguinte maneira:

- Efetua-se o dobramento a partir do lado *d* em dobras verticais de 185 mm; a parte final *g* é dobrada ao meio.
- Para o formato A2, é permitido um dobramento simplificado com dobras verticais de 192 mm.
- Em seguida a folha será dobrada segundo a altura, em dobras horizontais de 297 mm.
- A fim de facilitar o dobramento, aconselha-se assinalar nas margens, as posições das dobras.
- O canto superior esquerdo pode ser dobrado conforme indicado.

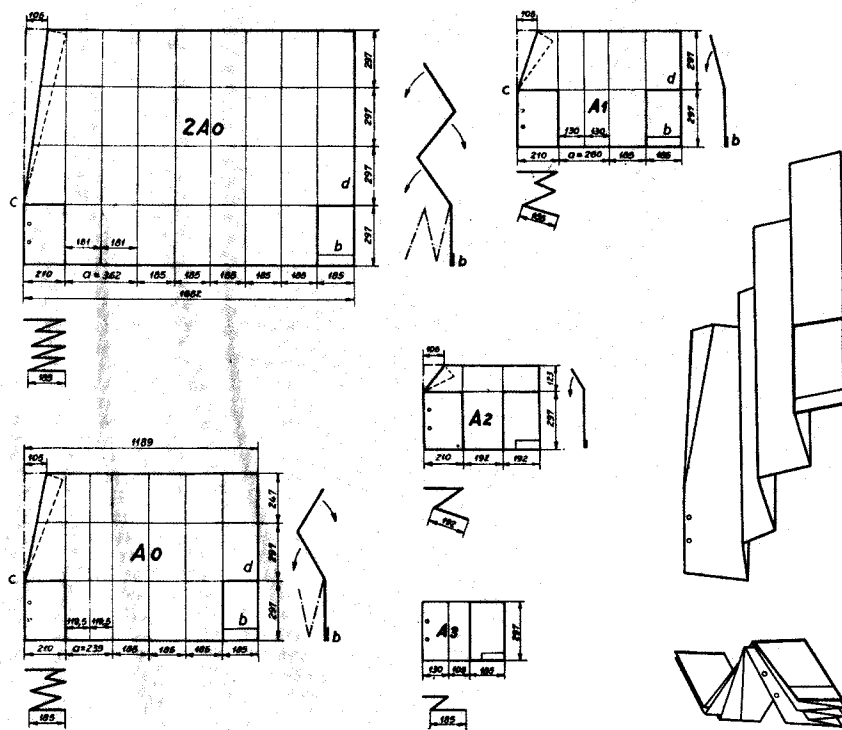

LETRAS E ALGARISMOS

7 - Os tipos de letras e algarismos usados em cotas, legendas e anotações devem ser bem legíveis, de rápida execução e proporcionais ao desenho, podendo ser verticais ou inclinados, executados a mão livre ou com auxílio de normógrafo ou LEROY.

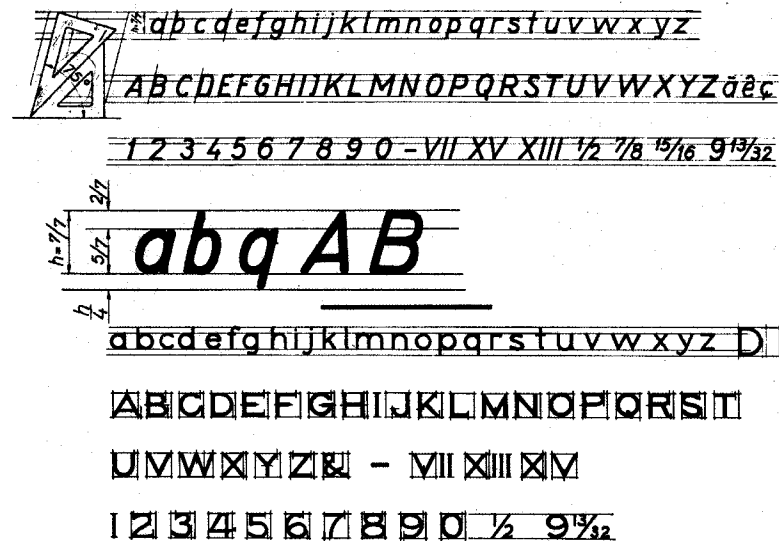

8 - Toda folha desenhada deve levar no canto inferior direito, um quadro destinado à legenda conforme modelos abaixo.

Formatos	L	H
A0, A1 e A2	175	90
A3, A4 e A5	120	35
A6 e A7	90	25

Formatos	L	H
A0, A1, A2 e A3	120	20
A4, A5 e A6	90	15

Desenhado (Data) (Nome)	Visado (Nome)	Firma
Copiado (Data) (Nome)	Approved (Nome)	Número
Escala		

Página	Denominação e observações	Material e dimensões
Data	Assinatura do chefe responsável	Firma
Desenho		
Escala		
em substituição de:		
Título do Desenho		Número

9 - Lista de peças, relação de materiais, descrição de modificações e indicações suplementares, quando necessárias, devem ser apresentadas preferivelmente acima ou então à esquerda da legenda.

LINHAS

10 - As linhas utilizadas em desenho técnico são :

		TIPO	EMPREGO
GROSSA	1		Arestas e contornos visíveis; circunferências de cabeça dos engrenagens; cabeço de filetes de rosca...
	2		Fundo de filetes de roscas; circunferência de pé das engrenagens...
MÉDIA	3		Seções rebatidas; peças colocadas diante do objeto representado; peças contíguas para po-las em relação; posições variáveis ou extremas no deslocamento; excesso para usinagem...
	4		Arestas e contornos invisíveis...
	5		Linhas de ruptura...
FINA	6		Linhas de chamada, cotas, hachuras...
	7		Hachuras
	8		Eixos de simetria; linhas de centro e demais linhas básicas.

Quando necessário podem ser utilizados outros tipos de linhas.

Recorrer a representação de arestas e contornos invisíveis (tracejado) apenas nos casos de maior clareza do desenho.

11 - Nos cruzamentos de linhas devem ser observadas as seguintes indicações:

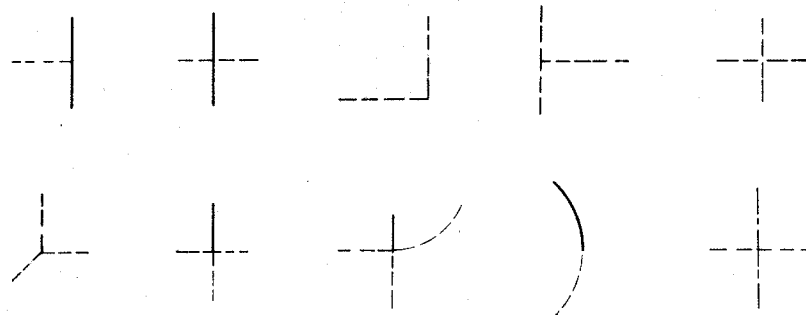

Exemplo :

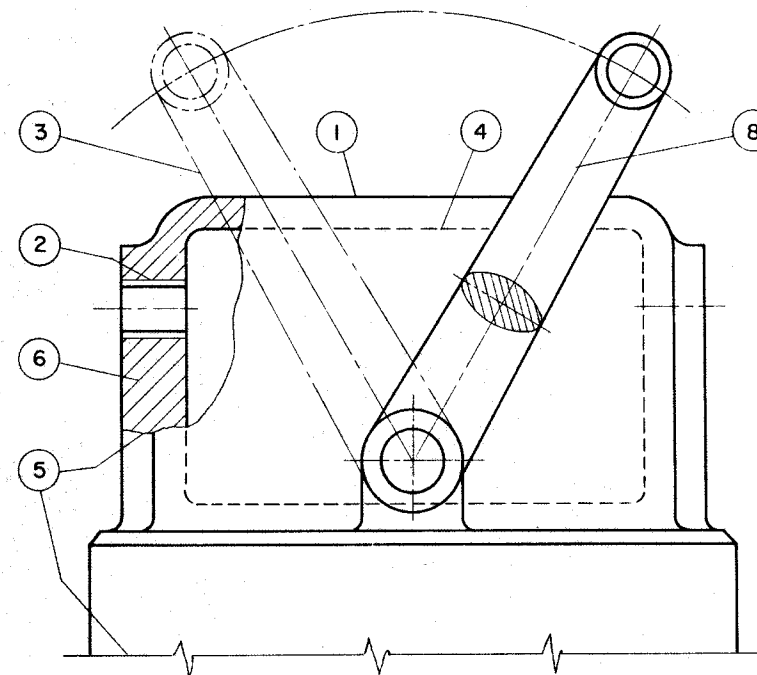

ESCALA

12 - A escala do desenho deve, obrigatoriamente, ser indicada na legenda.

13 - Constando na mesma folha desenhos em escalas diferentes, estas devem ser indicadas tanto na legenda como junto aos desenhos a que correspondem.

14 - As escalas recomendadas, além da natural (1:1), são :

PARA REDUÇÃO	
1: 2,5	1: 100
1: 5	1: 200
1: 10	1: 500
1: 20	1: 1000

PARA AMPLIAÇÃO	
2: 1	100: 1
5: 1	200: 1
10: 1	500: 1
20: 1	1000: 1

VISTAS

15 - As representações por meio de vistas serão obtidas, essencialmente, pelo rebatimento sobre o plano do desenho das projeções ortogonais da peça sobre as 3 faces internas de um triedro trirretangular, conforme mostra o desenho abaixo (v. Projeções ortogonais).

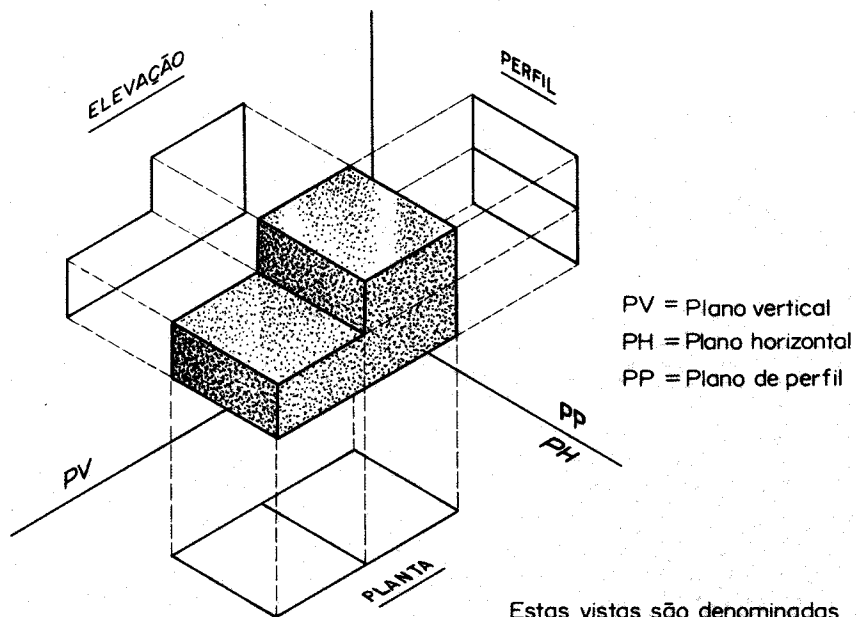

PV = Plano vertical
PH = Plano horizontal
PP = Plano de perfil

Estas vistas são denominadas
"vistas essenciais"

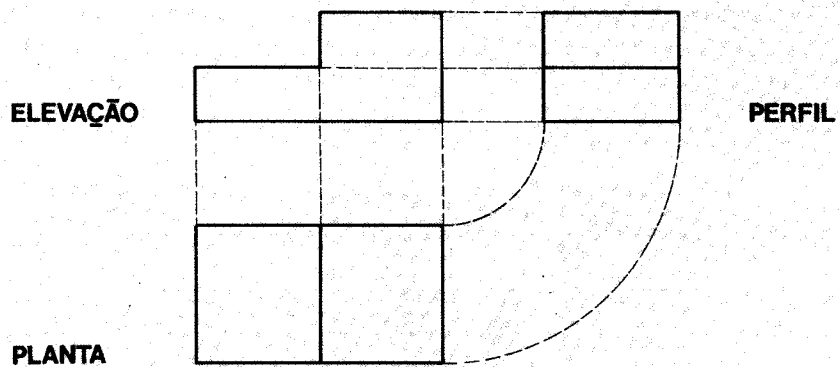

16 - Nos casos das vistas essenciais em posição normal, dispensam-se as suas denominações.

17 - As peças devem ser representadas na posição que melhor as caracteriza; em geral, na sua posição de montagem, podendo todavia, para desenho de detalhe, adotar-se qualquer posição conveniente.

18 - É permitida a representação das peças com menos das tres vistas essenciais quando isso não afetar a sua clareza.

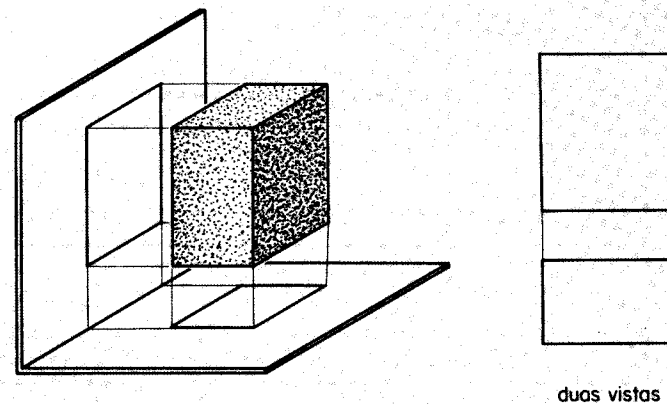

duas vistas

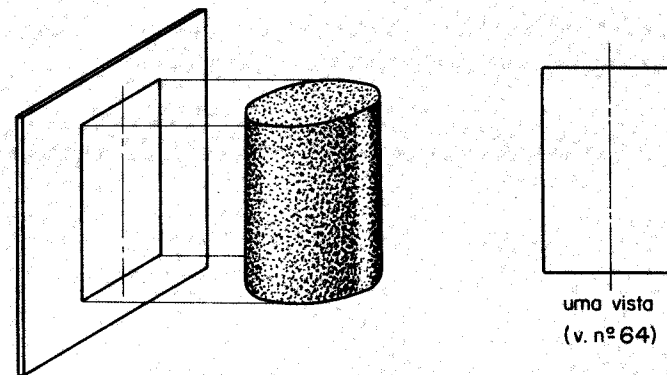

uma vista
(v. nº 64)

19 - Como elemento complementar, para melhor compreensão da peça representada, poderão também ser usadas as perspectivas (v. Perspectiva).

20 – Além das tres vistas essenciais, outras poderão ser usadas bem como rebatimentos parciais, vistas auxiliares, etc., quando isso for necessário. Estas vistas deverão ser denominadas e assinaladas por letras e flechas.

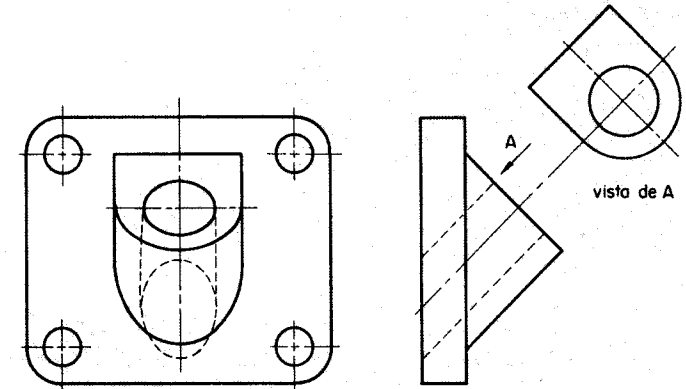
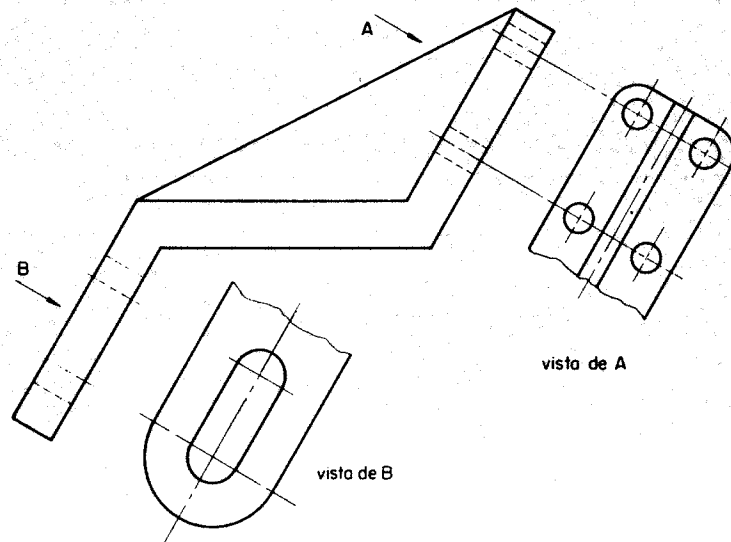
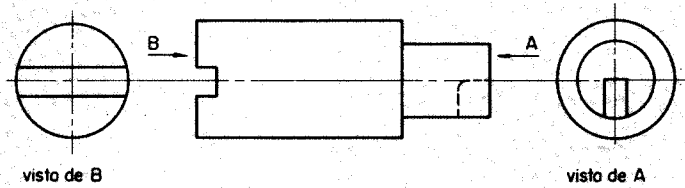
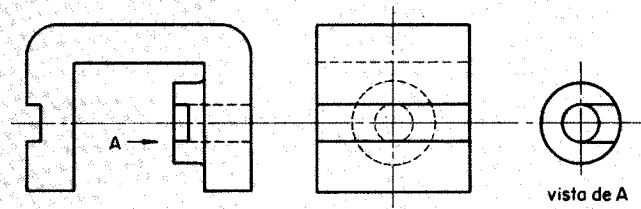

21 – Para ganhar espaço as vistas simétricas podem ser desenhadas em meia vista.

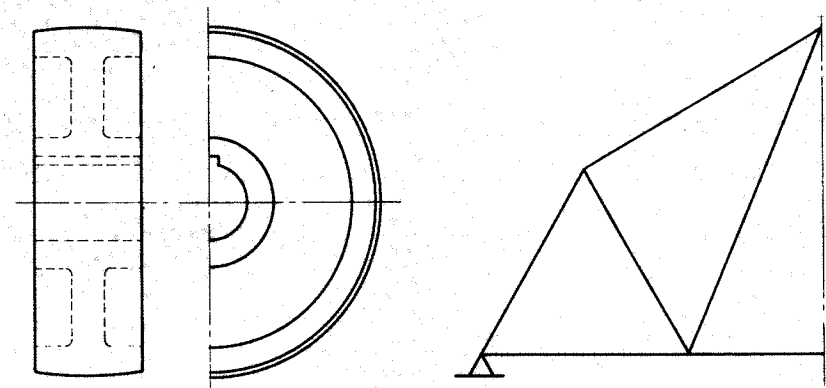
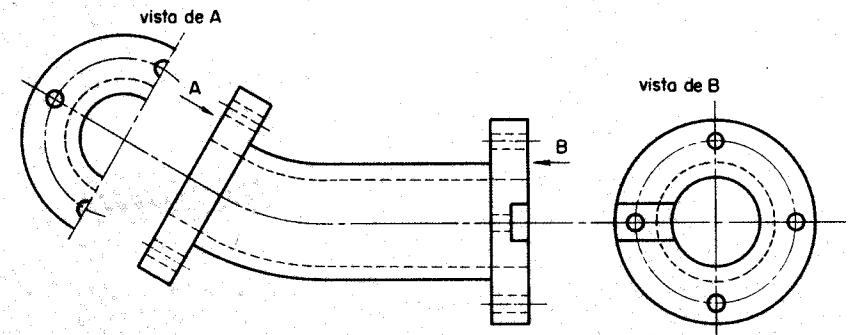

HACHURAS

22 - Os cortes das peças são destacadas por meio de hachurado que varia de acordo com os diversos materiais.

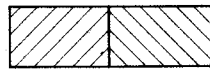

FERRO FUNDIDO



FERRO BATIDO E AÇO



BRONZE, LATÃO, COBRE



ALUMÍNIO, METAIS LEVES



METAL BRANCO



TERRA



BORRACHA, FIBRA

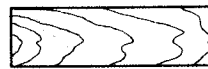

MADEIRA DE FACE



MADEIRA DE TOPO

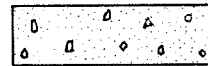

CONCRETO



PEDRA



LÍQUIDOS



GUARNIÇÃO



ENROLAMENTOS ELÉTRICOS

23 - As hachuras são habitualmente a 45° com o eixo da peça e devem ser feitas com linhas finas e paralelas.

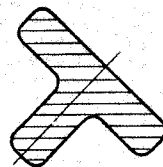
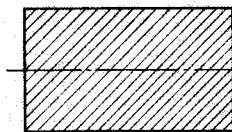

24 - As hachuras podem tomar outra direção quando houver necessidade de evitar seu paralelismo com o contorno da secção.

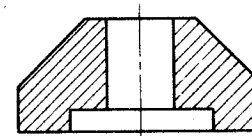

não aconselhável

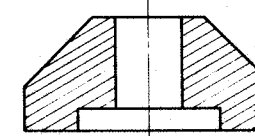

aconselhável

25 - As peças adjacentes devem figurar com hachuras diferindo pela direção ou pelo espaçamento.

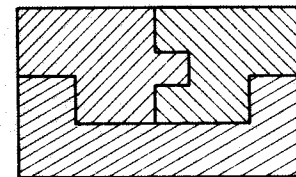

menos aconselhável

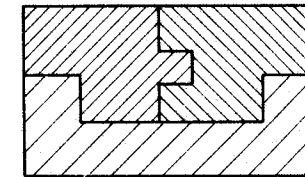

mais aconselhável

26 - Sendo a área a hachurar muito grande, pode-se limitar o hachurado à vizinhança do contorno, deixando a parte central em branco.

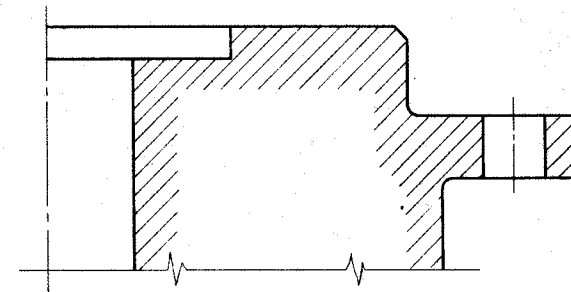

27 - Surgindo uma seção delgada, em vez de hachurada, ela pode ser enegrecida.

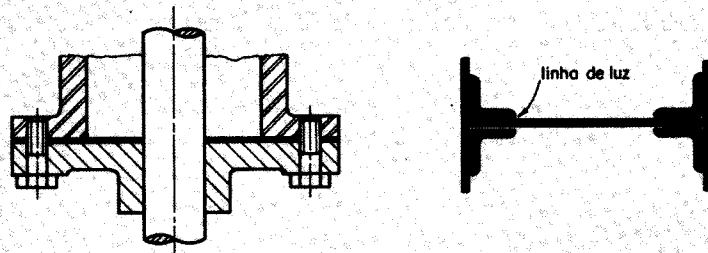

28 - Nas áreas hachuradas não se devem representar linhas invisíveis, excetuando-se os casos especiais em que se requer maior clareza.

CORTES E SEÇÕES

29 - O corte registra tanto a interseção do plano secante com a peça como a projeção da parte desta peça situada além desse plano secante.

30 - A seção registra somente a interseção do plano secante com a peça.

Tanto cortes como seções são empregadas para representar, com exatidão, detalhes ou perfis não revelados claramente nas outras vistas.

31 - A posição do plano secante e o sentido da visada são indicados por linha traço-ponto, flechas e letras.

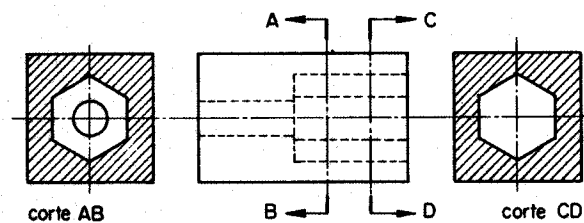

Nos casos evidentes, pode-se omitir esta indicação.

32 - Conforme a extensão em que se supõe cortada a peça, tem-se

corte total

meio corte

corte parcial

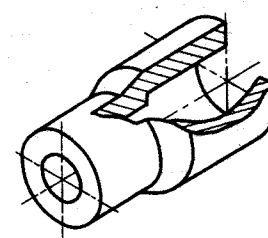
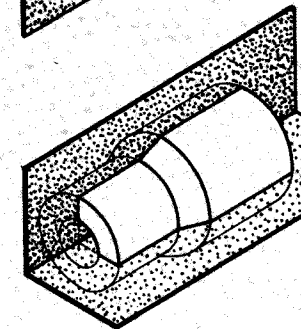
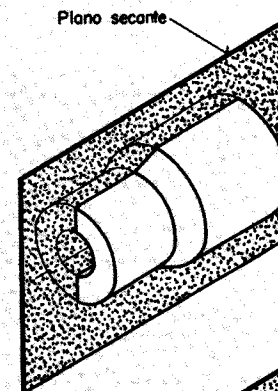

CORTE TOTAL

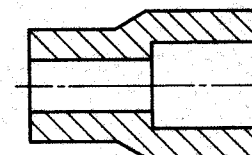

corte AA

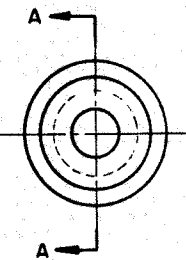

MEIO CORTE

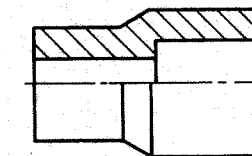

corte BB

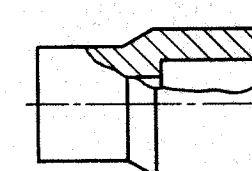
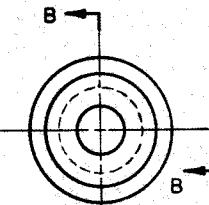

CORTE PARCIAL

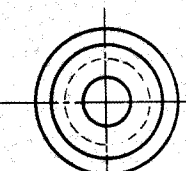

33 – Conforme a conveniência, um corte pode ser efetuado por uma associação de vários planos, constituindo um corte composto.

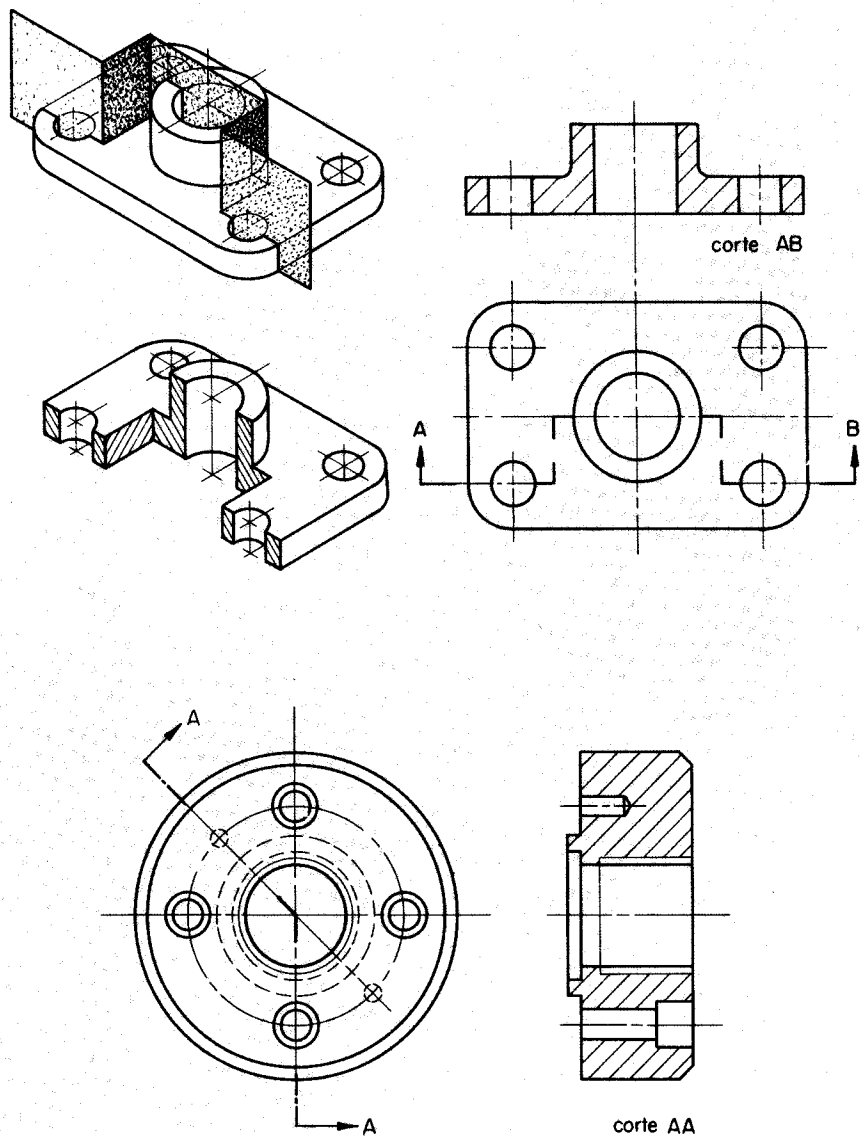

34 – Os cortes ou seções mostrando detalhes ao longo de uma peça, podem ser rebatidos dentro do contorno da vista, sem interrupção do traço da vista (a), com interrupção (b), ou ainda, removidos para fora desse contorno (c).

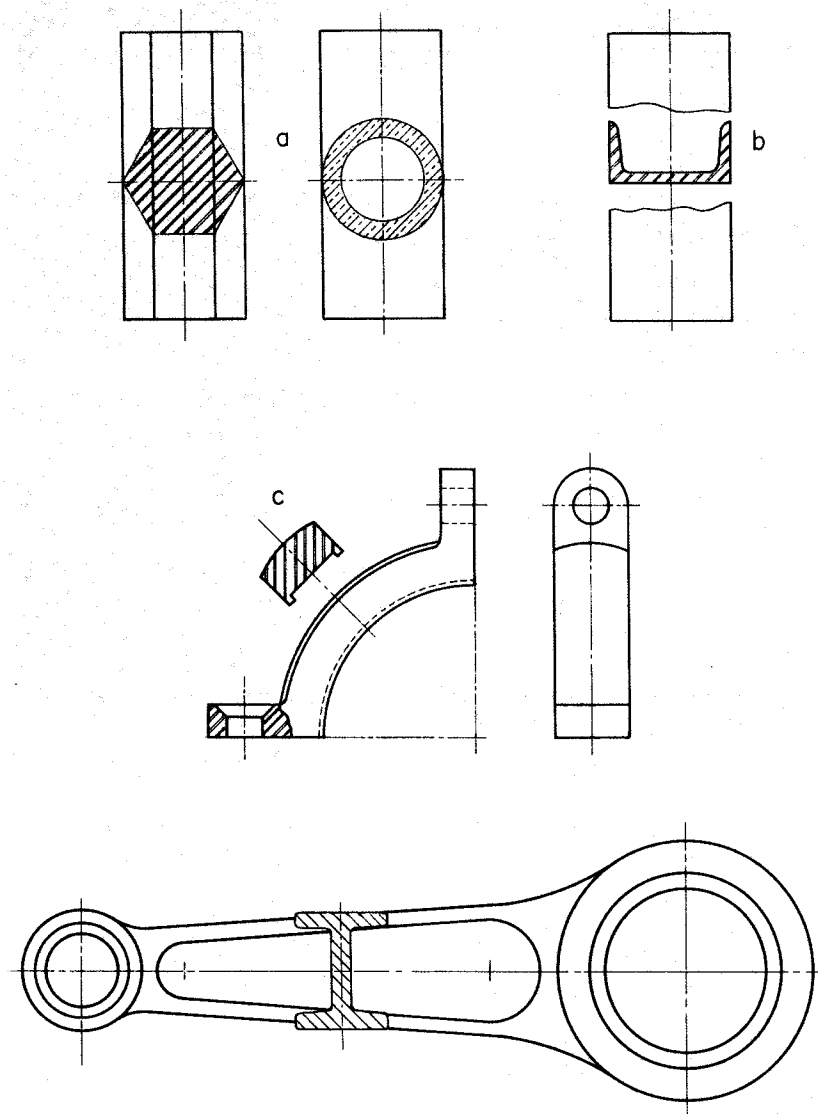

35 - Várias seções sucessivas podem ser indicadas no desenho.

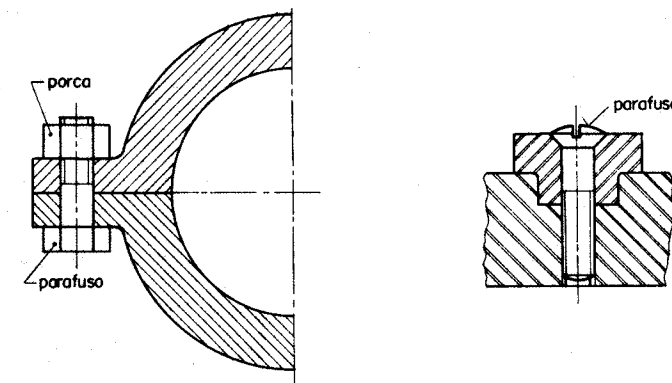
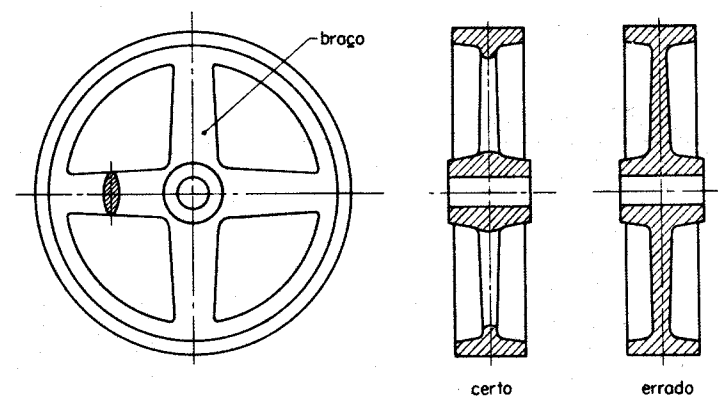
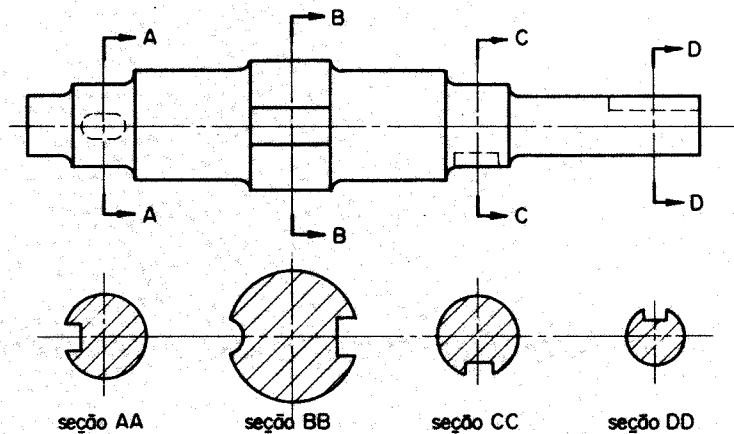

36 - Nervuras, braços das rodas, eixos, chavetas, parafusos, porcas, cavilhas, rebites e esferas não são hachurados, quando atingidos longitudinalmente pelo corte.

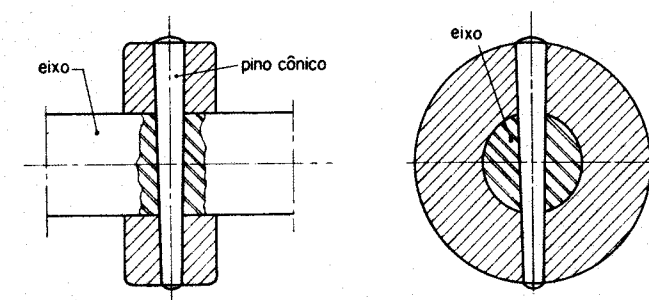
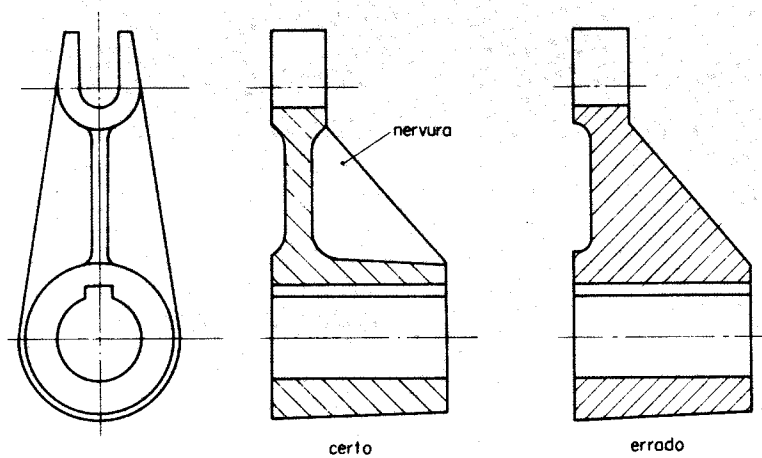

O eixo foi cortado somente para por em evidência a posição do pino.

Neste caso o eixo foi cortado completamente, pois, o foi em sentido transversal.

RUPTURAS

37 - Quando, para melhor aproveitamento de espaço no desenho, a peça for representada partida, as rupturas obedecerão as seguintes convenções.

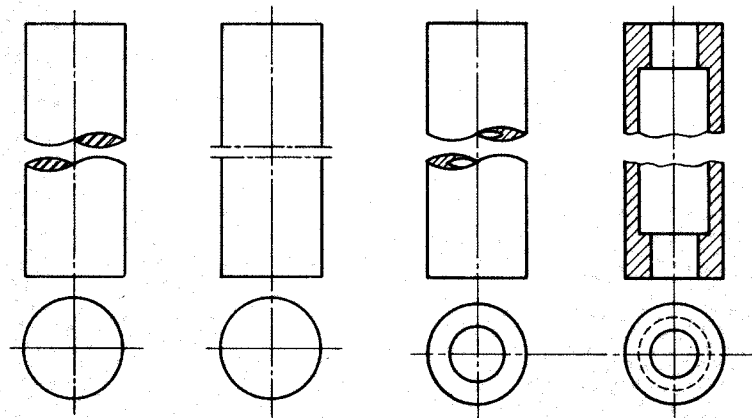

Peças redondas cheias

Peças redondas ocas

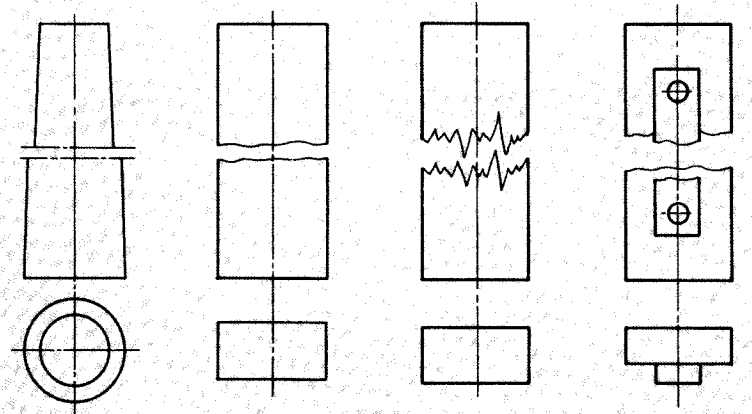

Peça cônica

Peça prismática

Peça de madeira

Peças superpostas

38 - Para peças representadas em corte (a) com hachuras não devem ser usadas linhas de ruptura, com exceção dos cortes parciais (b).

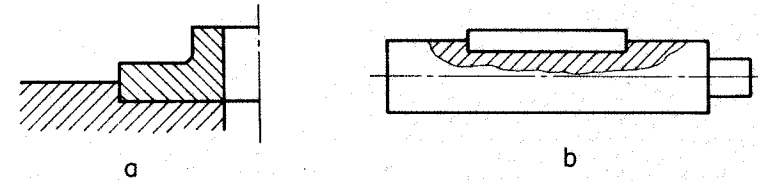

REPRESENTAÇÕES SIMPLIFICADAS E CONVENCIONAIS

39 - As interseções onde intervêm corpos redondos podem ser representadas como em a, preferindo-se entretanto a representação simplificada b.

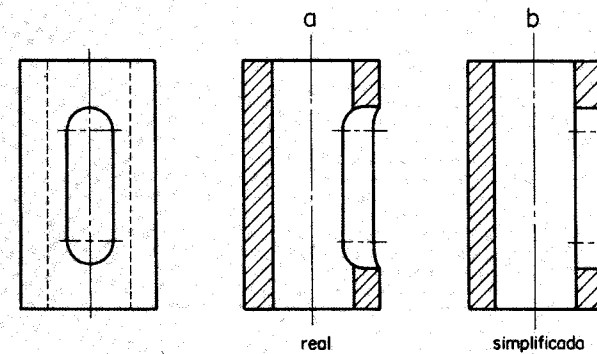

real

simplificada

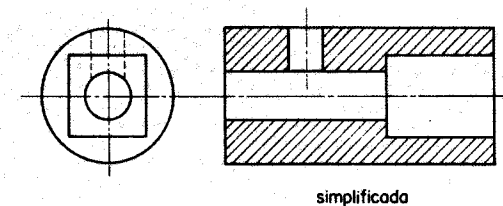

simplificada

40 - A fim de evitar o encurtamento que resultaria da verdadeira projeção de detalhes inclinados, faz-se a rotação de tais detalhes, de modo a projetá-los sem deformação.

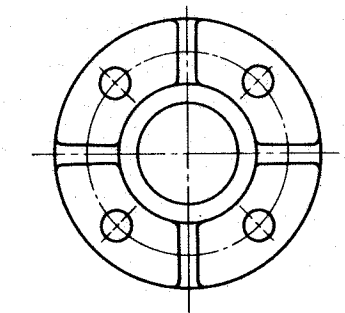
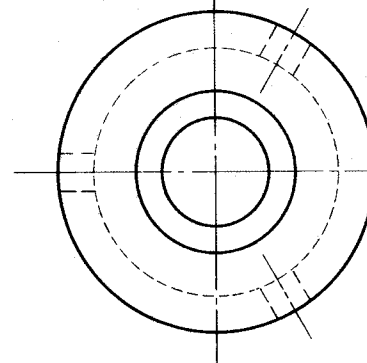
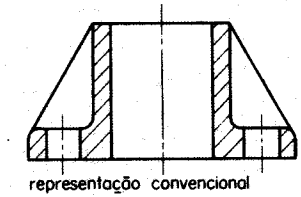
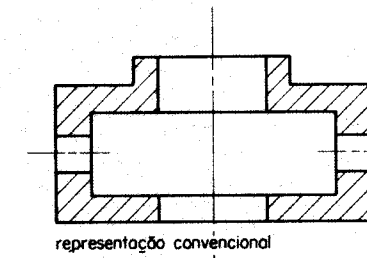
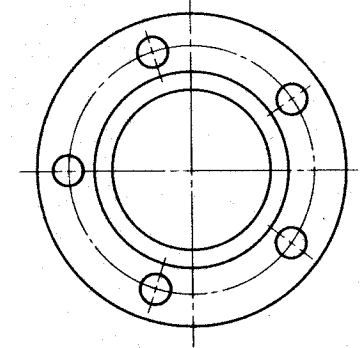
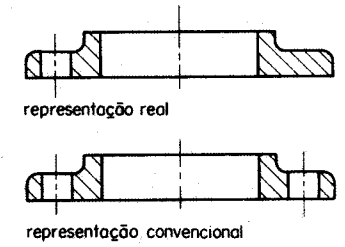
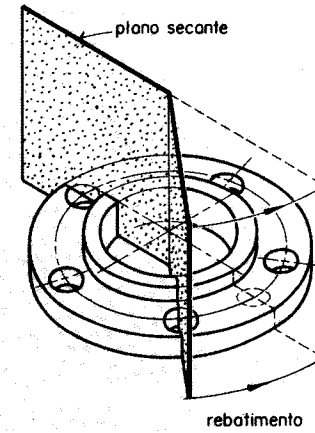
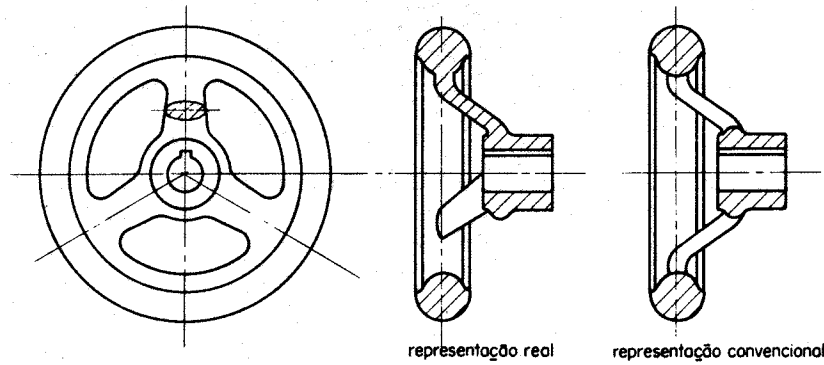
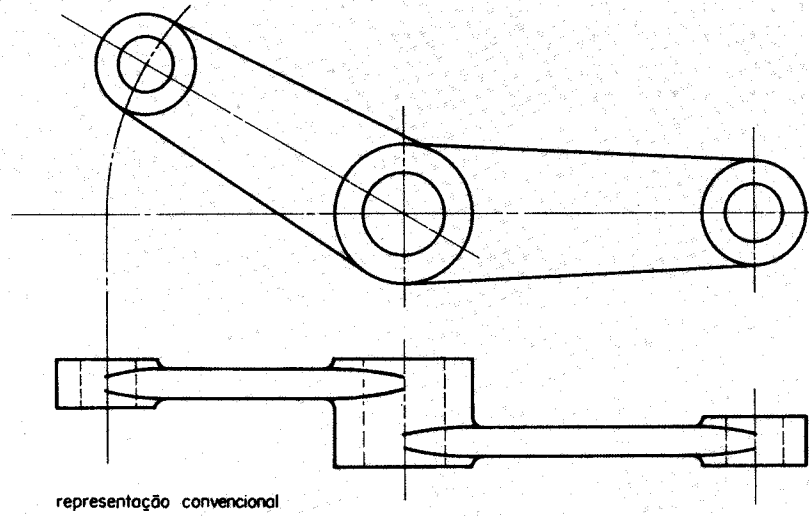

41 - Quando a intersecção de duas superfícies se fizer por uma concordância, empregar-se-ão as seguintes representações convencionais:

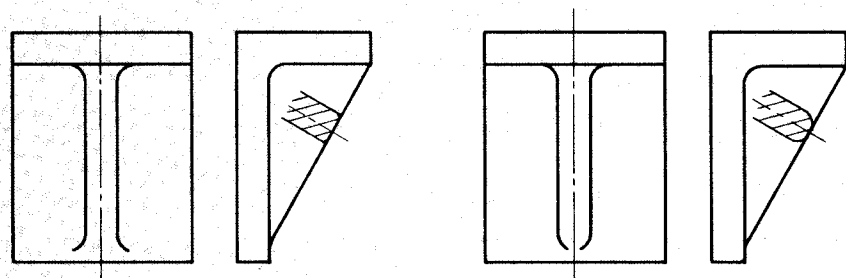
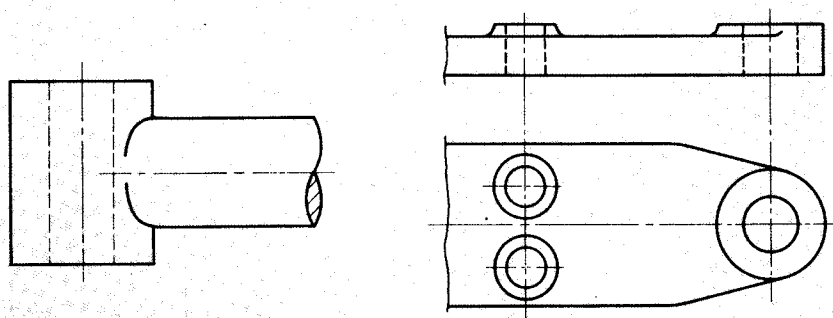
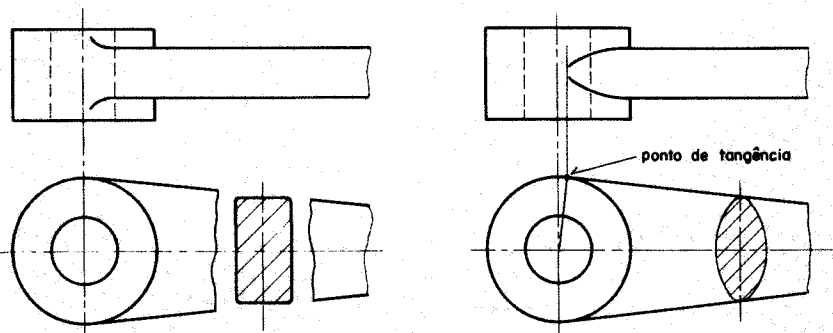

42 - Quando não ficar definida a forma da peça devido às concordâncias das superfícies que o delimitam, desenhar-se-ão linhas fictícias de intersecção.

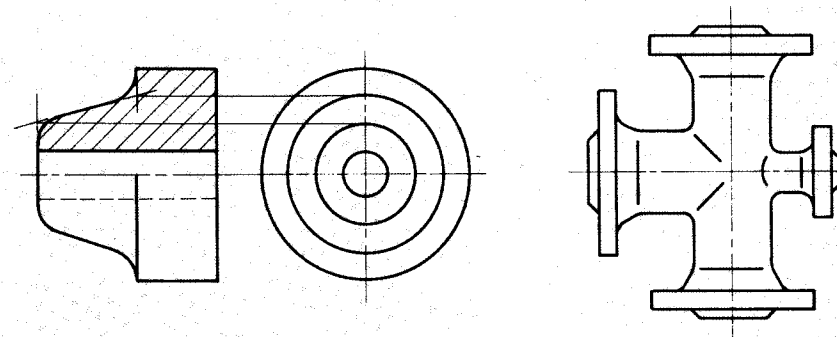

43 - As roscas têm as seguintes representações convencionais:

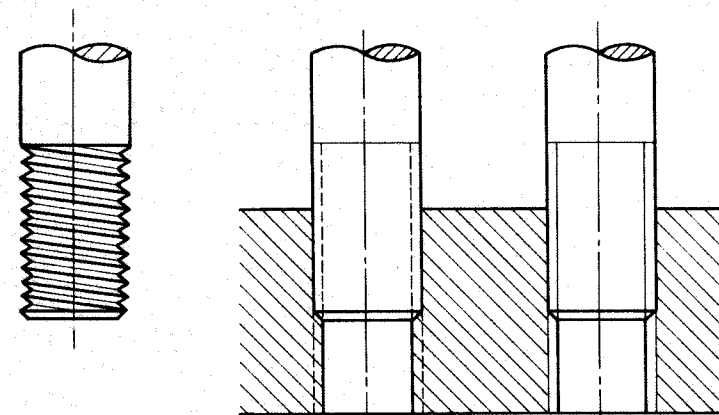

representação real

representações convencionais

44 - Faces planas são indicadas por duas diagonais que se cruzam.

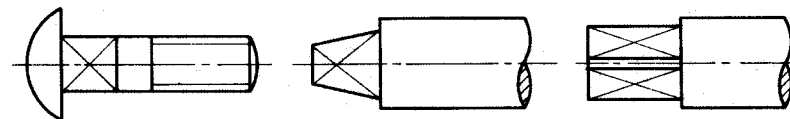

SINAIS

45 - Recomendam-se os seguintes sinais para serem colocados nas cotas, sempre antes dos algarismos.

- ∅ usado nas cotas que indicam diâmetro.
- ▣ usado nas cotas que indicam quadrado, quando o desenho não mostra claramente.
- R usado nas cotas que indicam raio de curvatura.
- r usado nas cotas que indicam arredondamento.
- # usado nas indicações de bitolas em chapas, fios, etc.
- ⊕ indica linha de centro.
- ↔ indica linha de simetria.

Os seguintes sinais indicam o tipo de perfil

- | | |
|--------------------|------------------|
| O redondo | T perfil T |
| □ quadrado | I perfil duplo T |
| ▭ chato | C perfil U |
| L JL J cantoneiras | ∩ perfil Z |

Para os demais sinais, consultar outros capítulos.

COTAS

46 - Os desenhos devem conter as cotas necessárias, distribuídas nas vistas que melhor caracterizam as partes cotadas, de forma a permitir a execução da peça sem recorrer a medição no desenho, nem à cálculo de medidas.

47 - Poderão deixar de ser cotadas certas partes de menor importância (pequenos arredondamentos de cantos vivos e outras concordâncias).

48 - Além das cotas, devem ser também incorporadas ao desenho as informações necessárias à completa elucidação de todos os detalhes da peça representada.

49 - A cotação deve ser executada considerando-se a função, a fabricação e a inspeção da peça.

50 - As cotas devem ser indicadas com a máxima clareza de modo a admitir uma única interpretação.

51 - Deve-se evitar a repetição de cotas.

52 - As cotas serão expressas em milímetros sem mencionar o símbolo desta unidade. Excepcionalmente, no caso de ser conveniente empregar outra unidade o símbolo desta deverá ser escrito obrigatoriamente ao lado da cota ou indicado junto à legenda.

53 - As linhas de cota são representadas por traço fino, limitadas pelas linhas de chamada.

54 - As linhas de chamada são representadas por traço fino, e são prolongadas um pouco, além da última linha de cota que abrangem.

55 - As linhas de cota são terminadas em suas extremidades por flechas, conforme indicação abaixo.

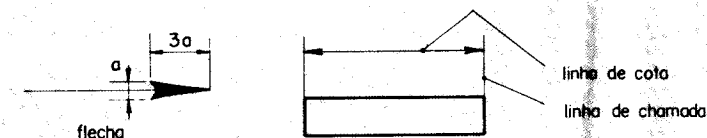

56 - Os números que exprimem os valores da cota são escritos, geralmente, equidistantes dos extremos da linha de cota e acima dela. Eventualmente, a linha de cota pode ser interrompida para colocar o algarismo.



57 - Os algarismos são escritos segundo a direção das linhas de cota, evitando-se que estas linhas tenham uma direção compreendida dentro do ângulo de 30° hachurado, para que a leitura seja efetuada sem necessidade de virar o desenho. Dessa forma a leitura será efetuada de frente ou do lado direito do desenho.

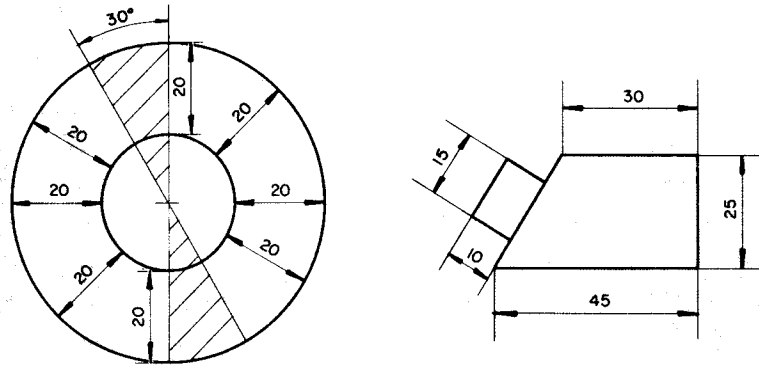

58 - Não se deve usar como linhas de cota, eixos, linhas de centro, arestas e contornos de objeto, com exceção de desenhos esquemáticos como estruturas.

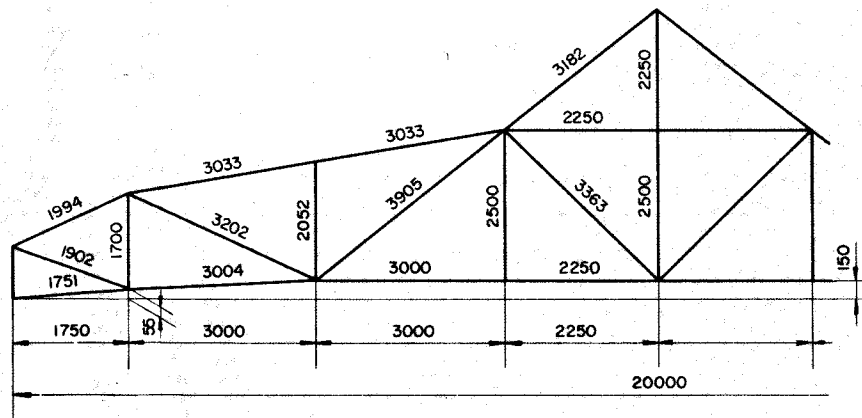

59 - Em casos especiais as linhas de chamada e as linhas de centro podem servir de linhas de cota.

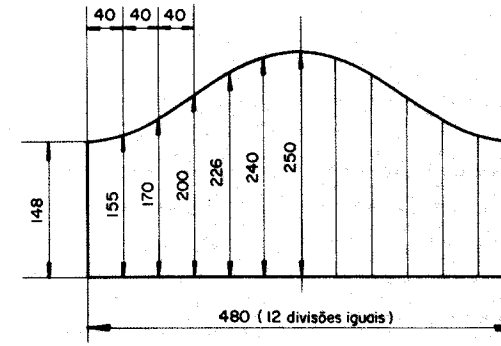

60 - As linhas de centro, eixos, arestas e contornos de peças podem substituir quando conveniente, as linhas de chamada.

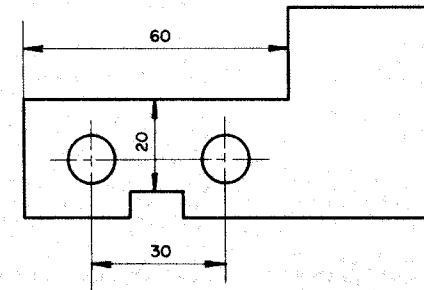

61 - As linhas de chamada podem em caso de necessidade, serem traçadas obliquamente, mas paralelas entre si.

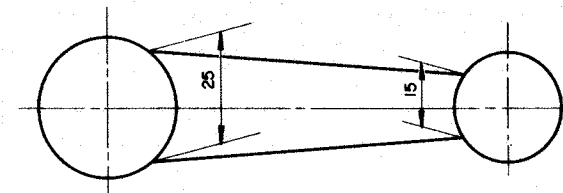

62—Quando houver necessidade, a cota pode ser referida às linhas de construção.

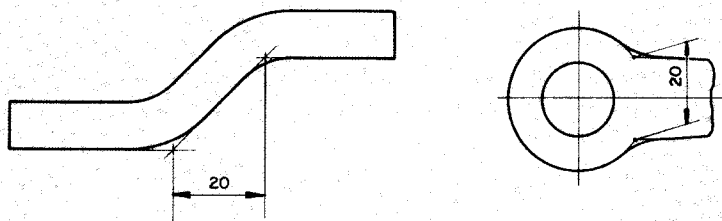

Não cotar as partes representadas com linhas invisíveis.

63—Na falta de espaço deve-se desenhar as flechas externamente para atender os requisitos de melhor clareza.

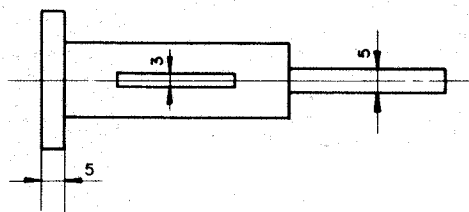

64—Quando na vista cotada for evidente que se trata de diâmetro ou quadrado, o respectivo símbolo pode ser dispensado.

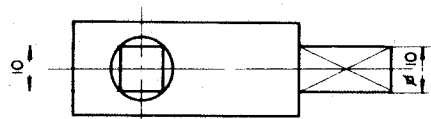
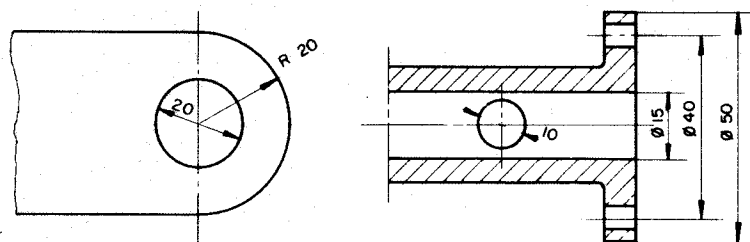

Estes símbolos dispensam em muitos casos outras vistas.

65—As linhas de cotas de raios de arcos e de arredondamentos não levam flechas na extremidade que está no centro do arco.

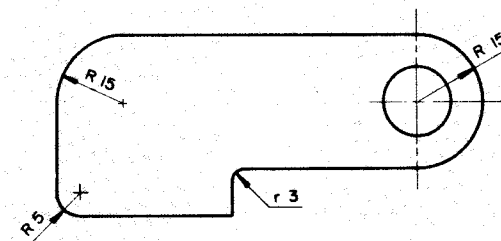

66—Na impossibilidade de colocar flechas usar as indicações abaixo:

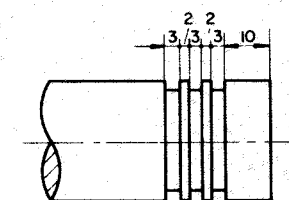
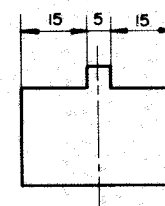

67—Quando houver necessidade de referir no desenho informação escrita ou simbólica pertencente a um detalhe da peça procede-se conforme indicação abaixo:

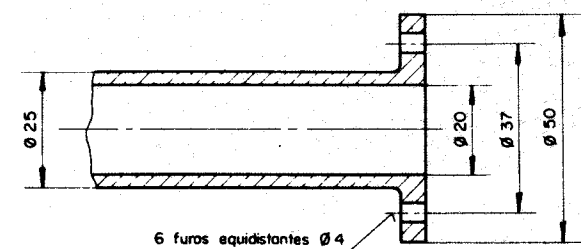

68—Quando uma cota for escrita no interior de uma seção as hachuras devem ser interrompidas.

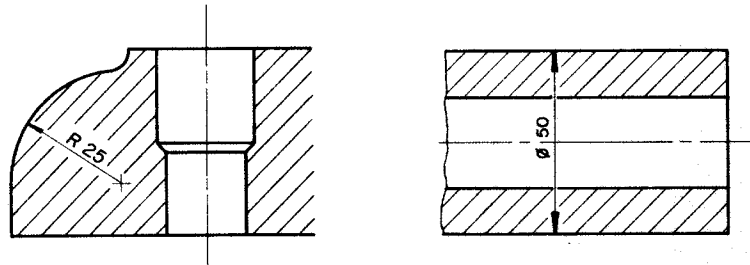

69—Deve-se evitar, se possível, que linhas de cota se cruzem entre si ou com linhas de desenho.

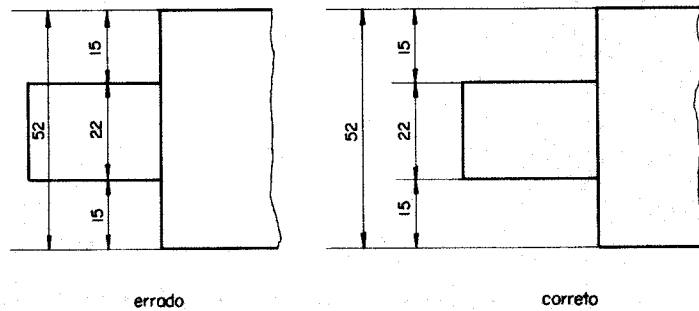

70—A colocação das cotas deve atender aos requisitos de maior clareza, compreensão e facilidade de execução do desenho, evitando qualquer cruzamento de linhas com números e letras.

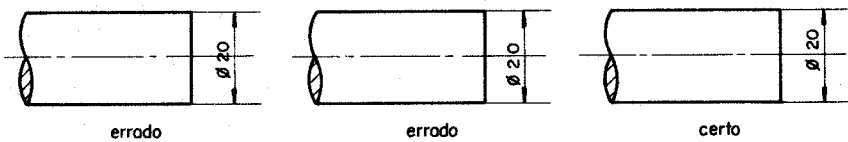

71—Cotas que tenham a mesma direção são dispostas em série e quando admitirem origem comum, em paralelo. É permitida a combinação das duas modalidades.

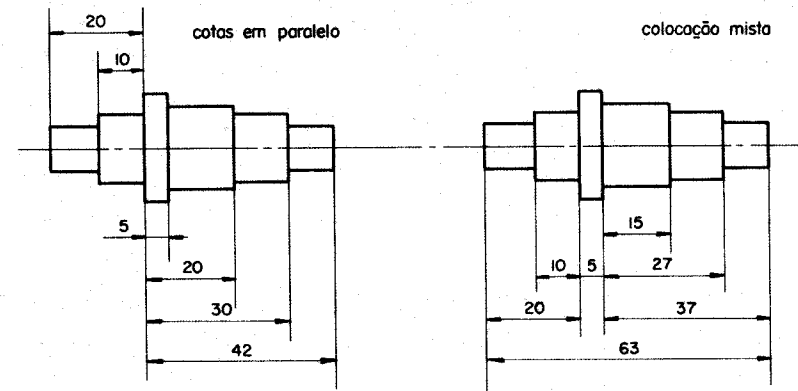
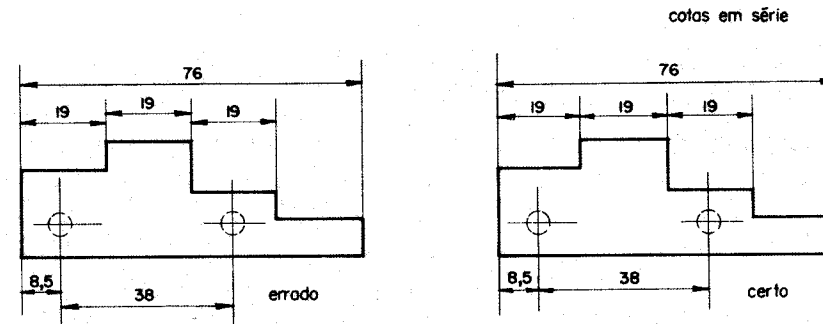

72—As cotas em paralelo também podem tomar a seguinte disposição.

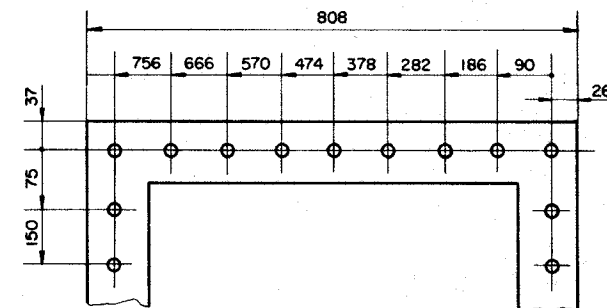

73 - Evitar colocar mais que duas cotas que passam pelo centro da circunferência.

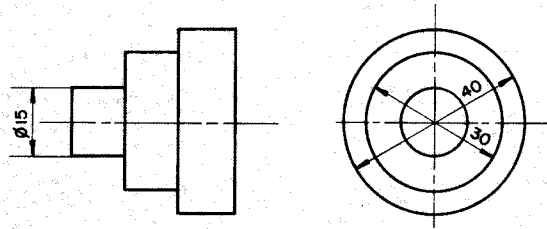

74 - Indicar a distância entre os centros dos furos e não entre as paredes.

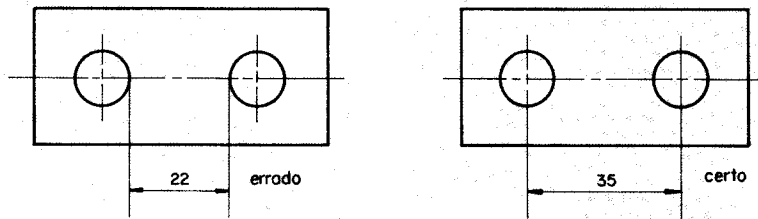

75 - É aconselhável separar as cotas internas das externas.

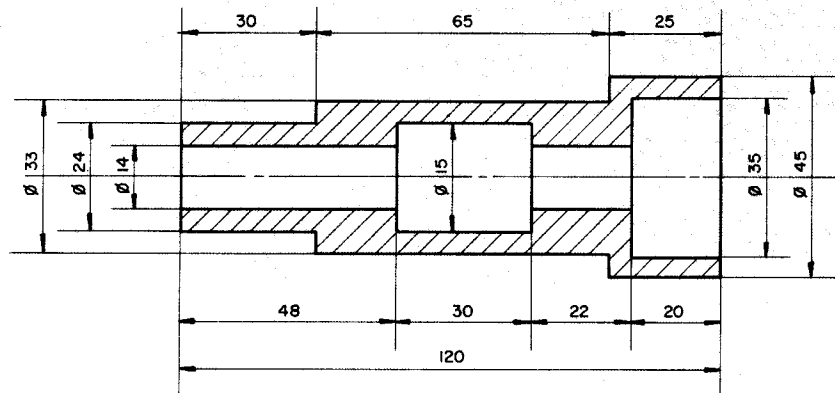

76 - As cotas maiores são colocadas por fora das menores, a fim de evitar cruzamentos.

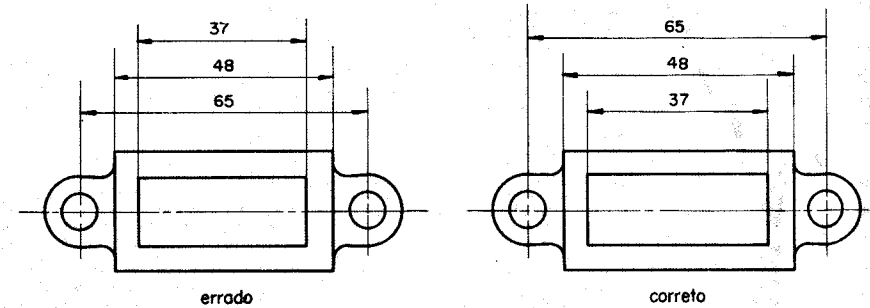

77 - Deve-se colocar sempre as cotas parciais e a total.

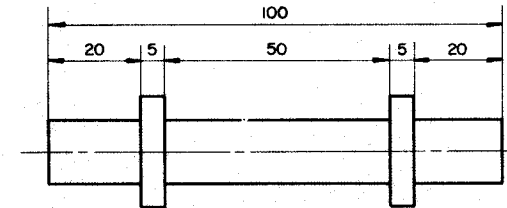

78 - As peças partidas são cotadas conforme indicação abaixo.

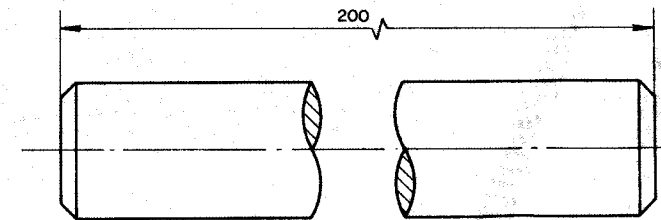

79 - Contornos irregulares podem ser cotados conforme indicação abaixo.

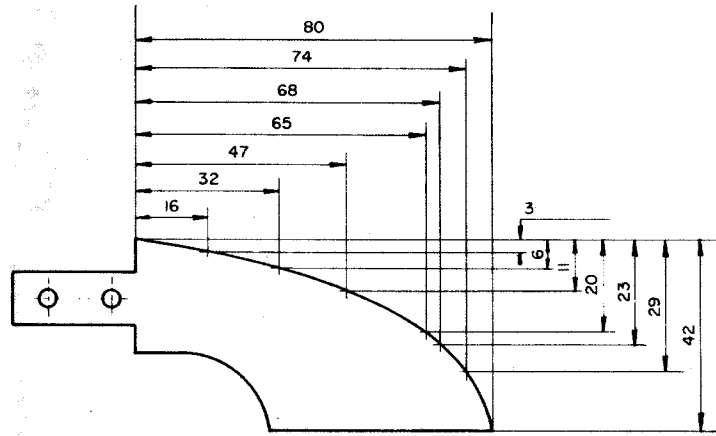

82 - Os elementos esféricos são cotados pelo diâmetro ou pelo raio, precedido da palavra "esfera".

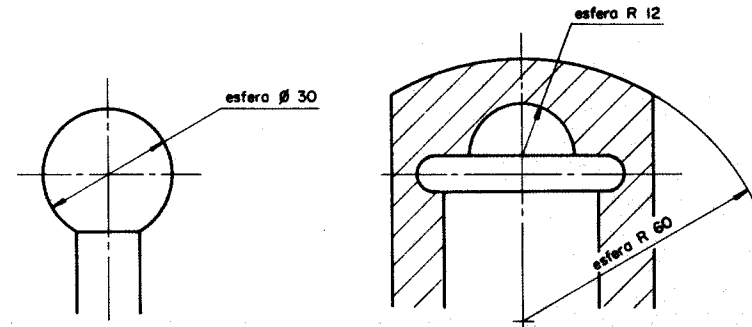

80 - Para os grandes raios a linha de cota pode ser quebrada em trechos paralelos.

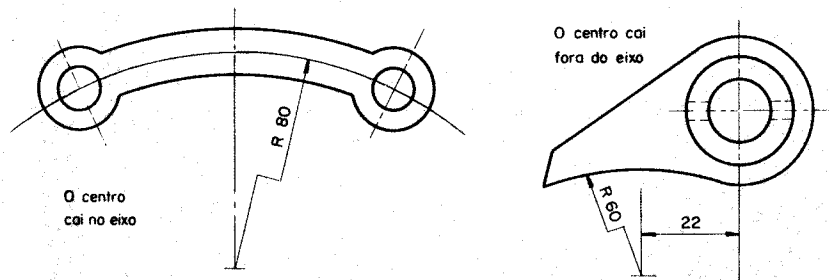

83 - Cotas de peças simétricas podem ser interrompidas.

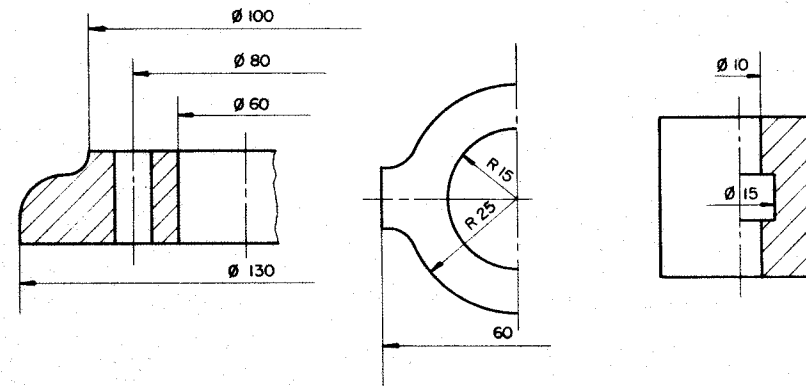

81 - A cotagem de circunferências pode ser feita das seguintes maneiras:

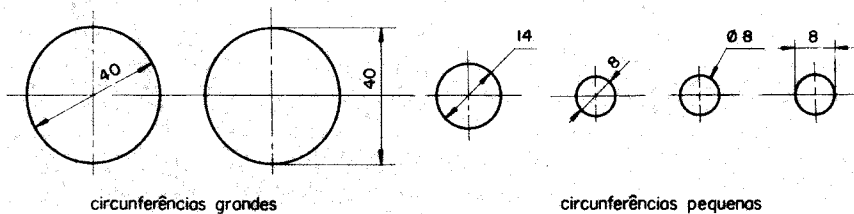

84 - No caso de se modificar alguma cota do desenho, a cota substituída será cortada por um traço, de modo, porém, que possa ser lida. A nova cota deverá ser colocada acima da substituída.

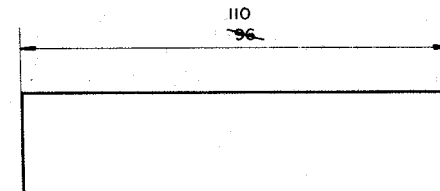

85 – As cotagens de corda, desenvolvimento de arco e ângulo se diferenciam conforme indicações abaixo.

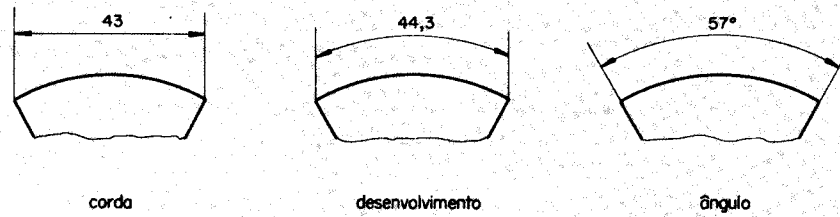

86 – Conforme o espaço disponível no desenho, os ângulos podem ser cotados como indicam as figuras abaixo:



87 – O arco de cota do ângulo deverá ter o centro no vértice.

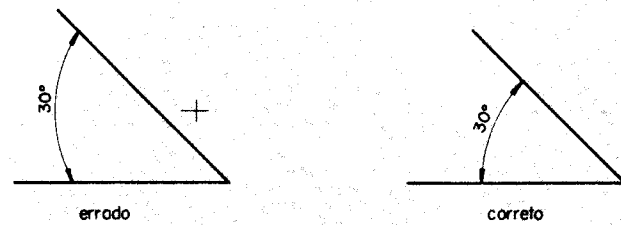

88 – Em peças simétricas, a cota pode ser interrompida.

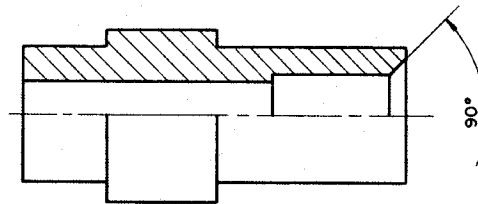

89 – A colocação dos algarismos se efetuam da seguinte forma.

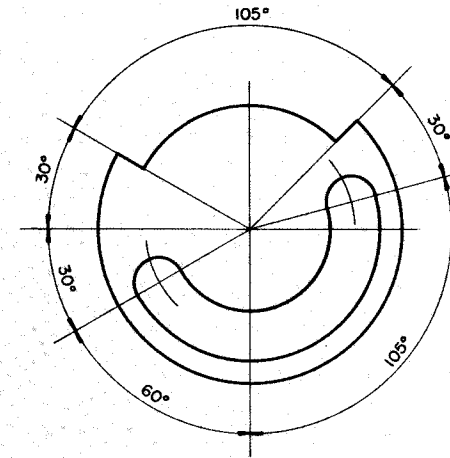

90 – Exemplo de disposição de cotas angulares :

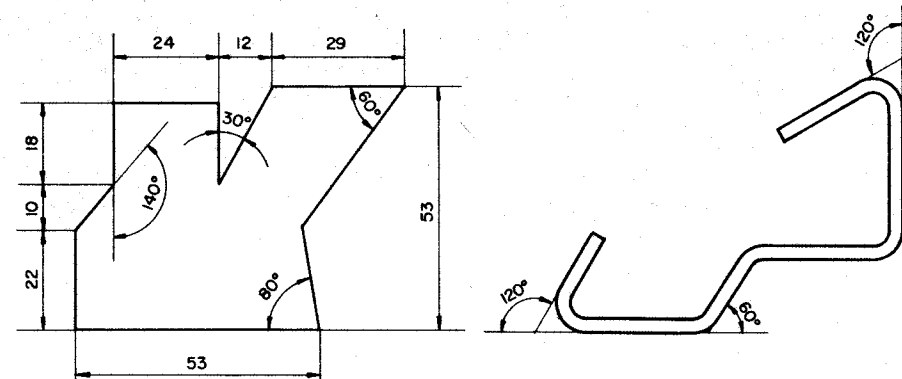
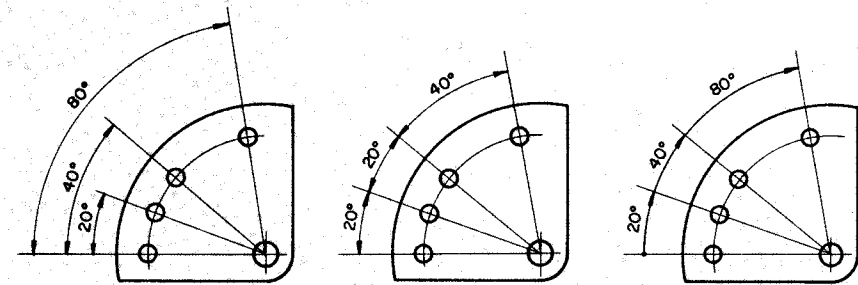

91 - Os furos podem ser cotados em coordenadas polares, em coordenadas cartesianas ou coordenadas mistas.

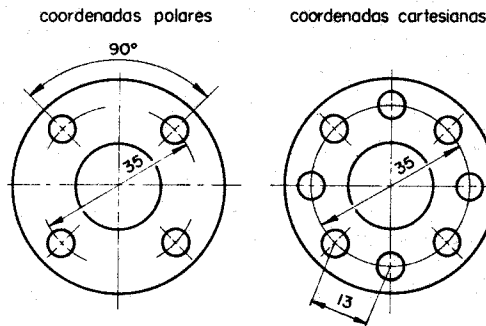
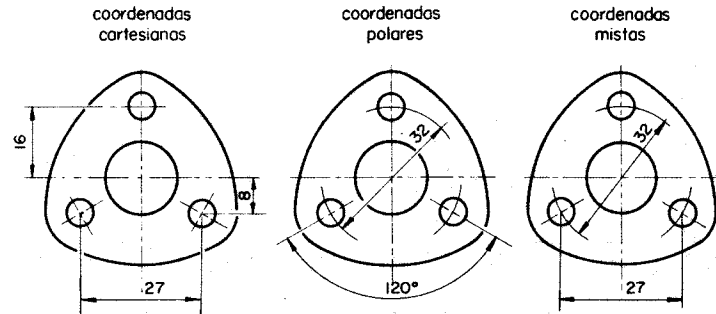

92 - Os chanfros (ch) podem ser cotados das seguintes maneiras:

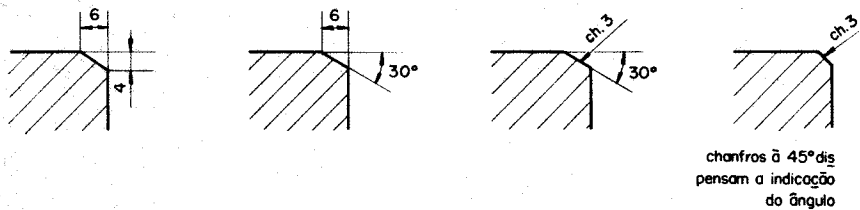

Os chanfros aconselháveis são: 0,1 - 0,5 - 1 - 2 - 3 - 4 - 5.
Evitar chanfros côncavos.

93 - Os arredondamentos são cotados da seguinte maneira.

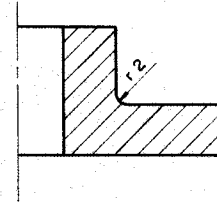

Os arredondamentos aconselháveis são os seguintes:

0,2 - 0,5 - 1 - 2 - 3 - 5 - 10

Evitar arredondamentos convexas.

94 - As peças em perspectiva devem apresentar linhas de chamada, linhas de cota, algarismos, notas e símbolos também em perspectiva.

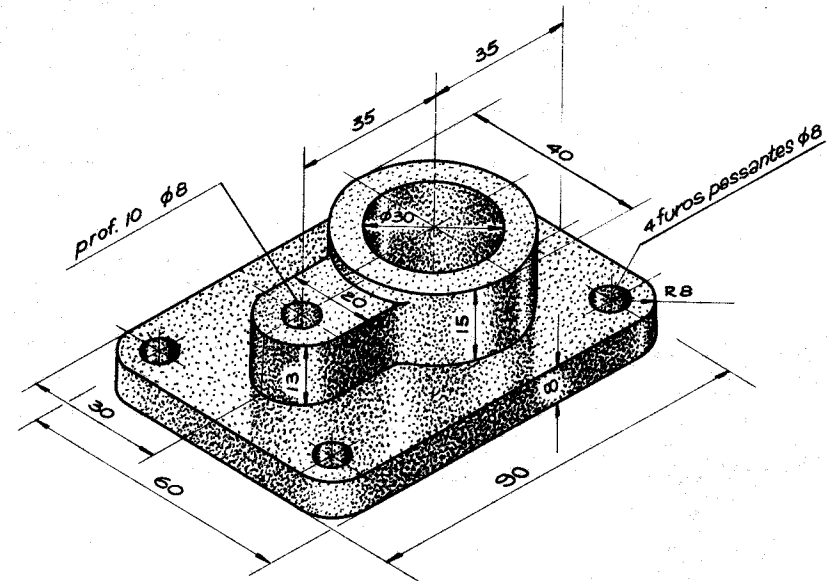

95 - Sinais e convenções para solda, rebites, canalizações, conicidade, inclinação, tolerância, sinais de usinagem, etc. estão indicadas em outros capítulos.

RECOMENDAÇÕES E CONSELHOS

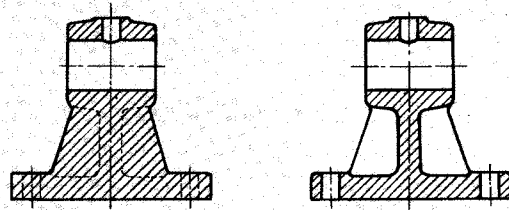

errado correto
Representação de um suporte com nervura.

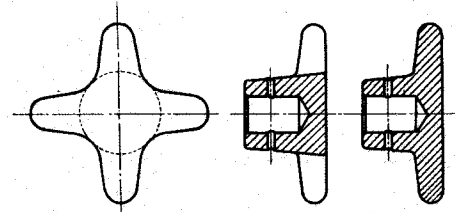

correto errado
Representação de um manípulo de comando

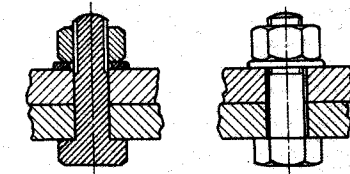

errado correto
Representação de uma união
com parafuso passante

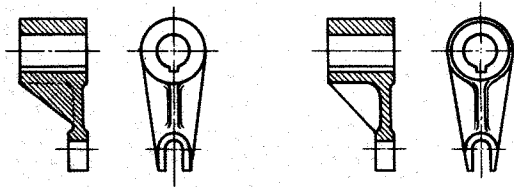

errado correto
Representação de um suporte com nervura.

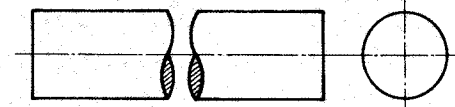

representação errada

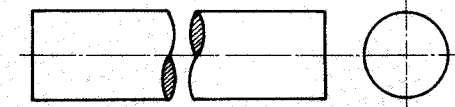

representação correta

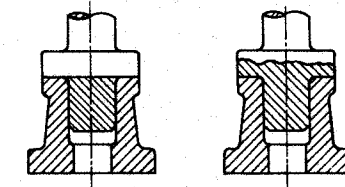

errado correto

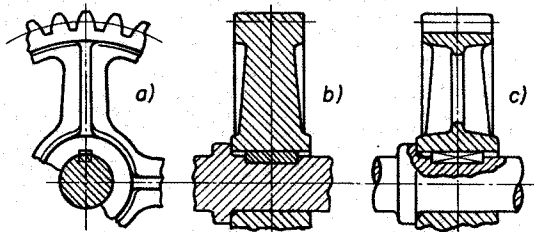

correto errado correto
Representação de uma engrenagem

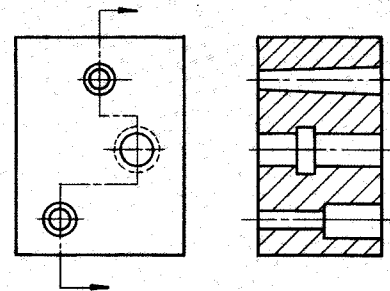

seção em vários planos

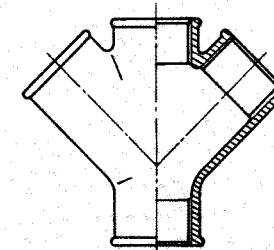

Representação em
meio corte

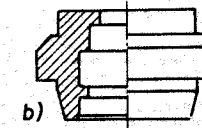
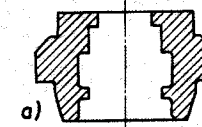

a) errado b) correto

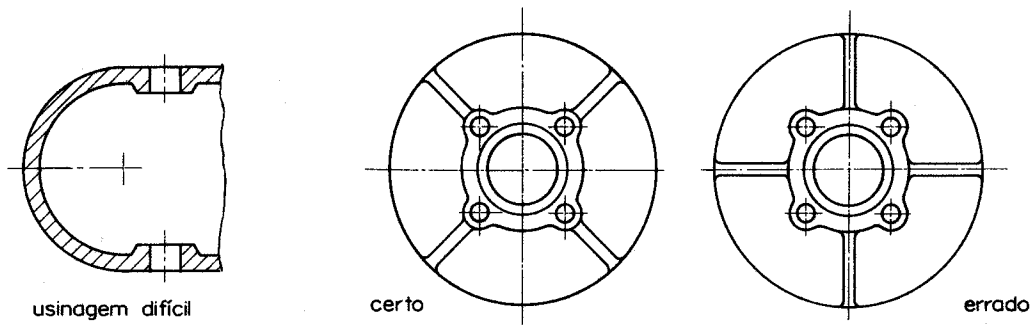

usinagem difícil

certo

errado

Disposição das nervuras

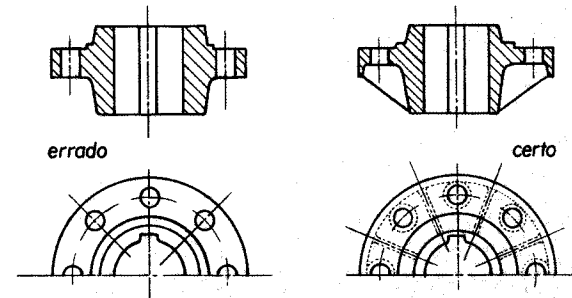

errado

certo

Alívio no cubo de uma roda

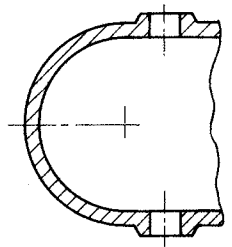

usinagem mais fácil

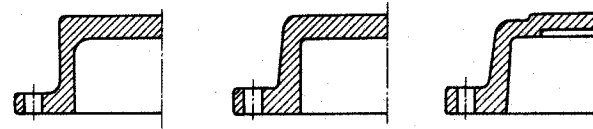

errado

certo

melhorado

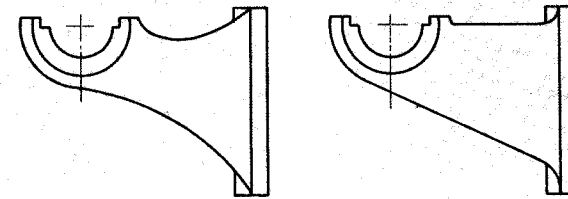

evitar

correto

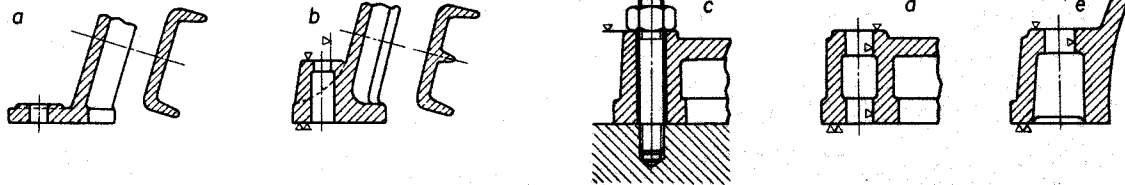

Base das máquinas: a) errado b) certo c) certo d) certo e) melhorado.

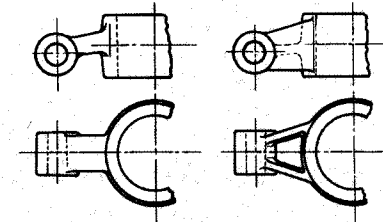

errado

certo

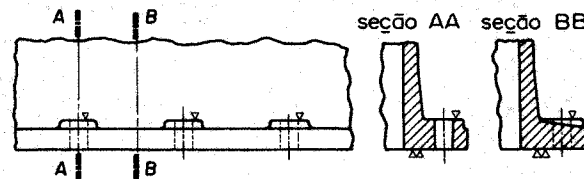
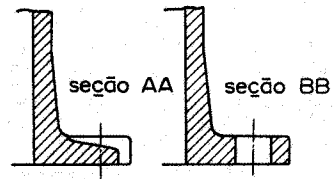
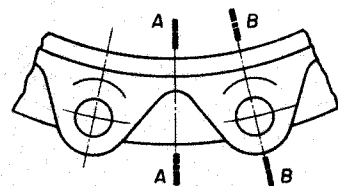

seção AA seção BB

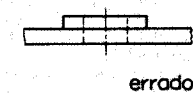

errado

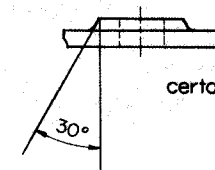

certo

Reforçar os furos para parafusos de união, fixação ou chumbadores

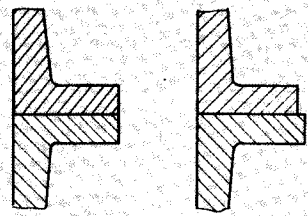

certo

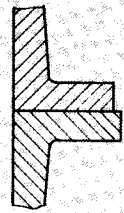

errado

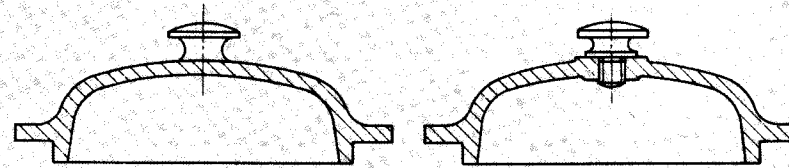

dificuldade na fundição

correto

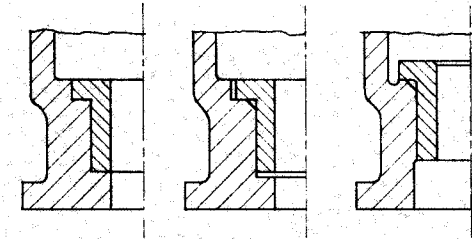

errado

certo

melhorado

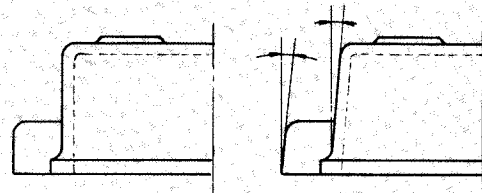

errado

certo
para facilitar a
retirada do molde

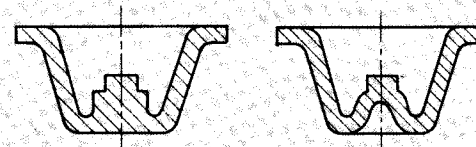

errado

certo

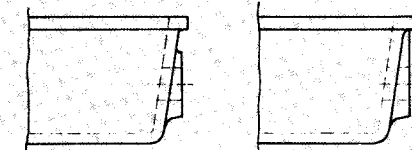

evitar

correto

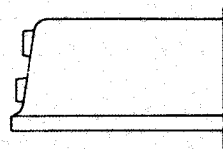

errado

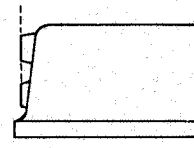

para facilitar o
acabamento

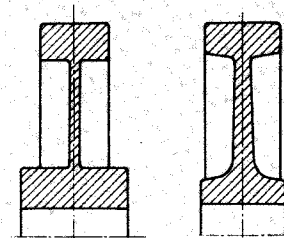

errado

certo

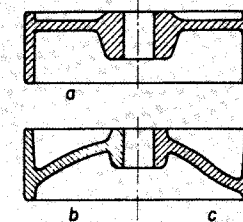

a)errado b)certo c)melhorado

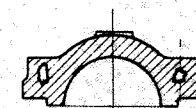

errado

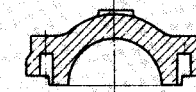

certo

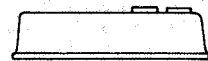

evitar

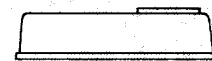

para facilitar o acabamento

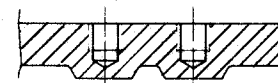

evitar

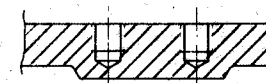

certo

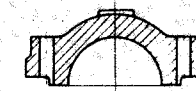

melhorado

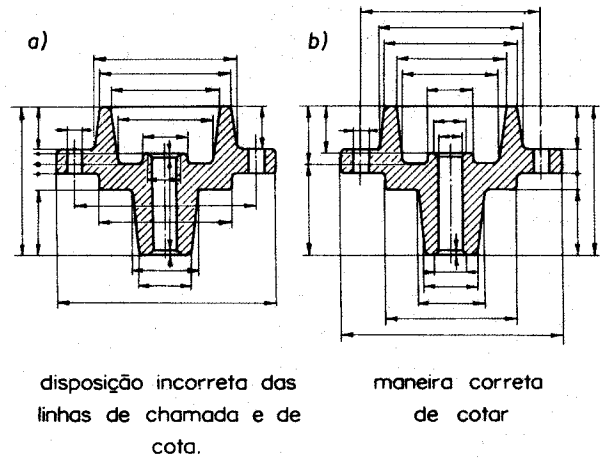
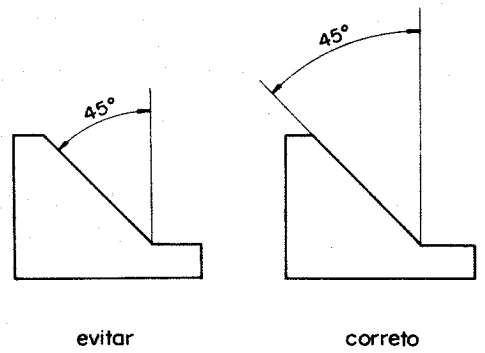
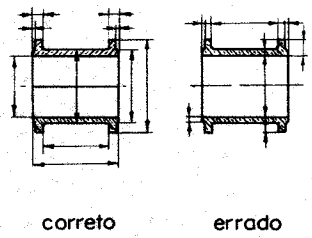
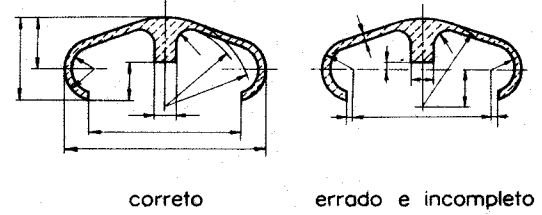
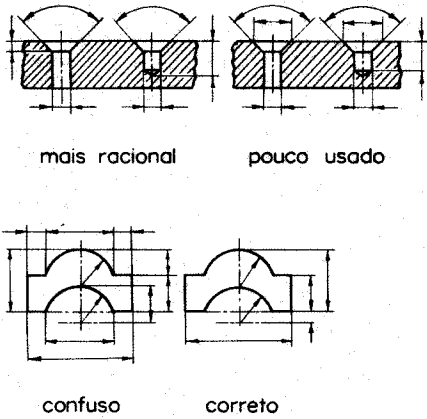
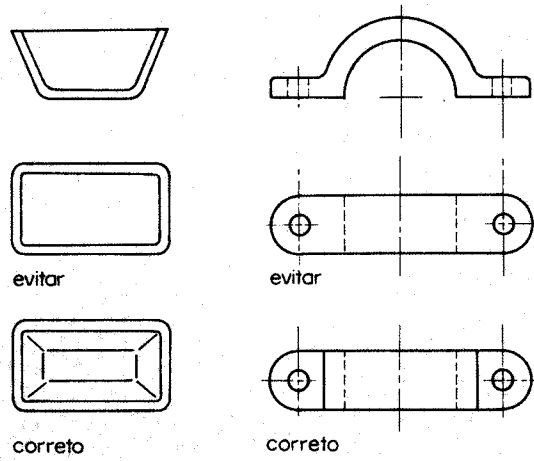
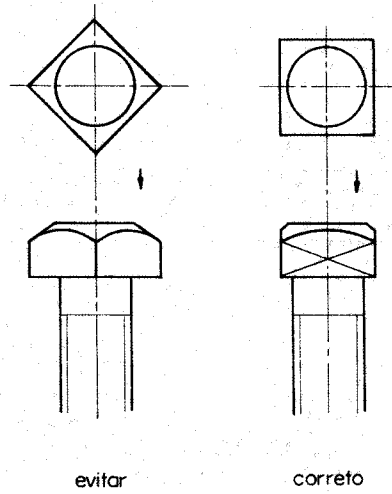
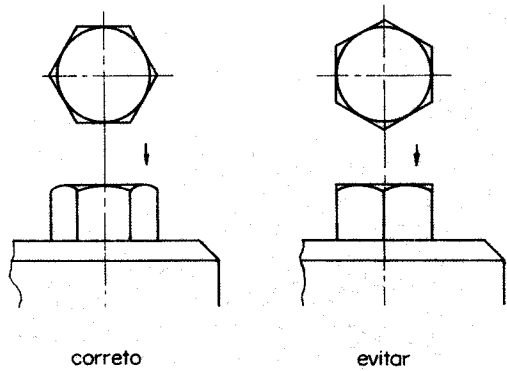
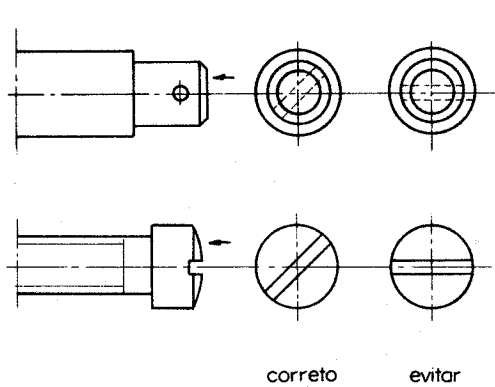

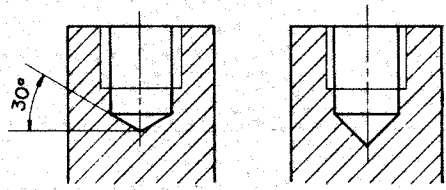

correto

errado

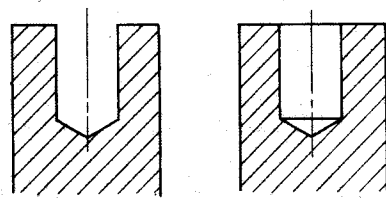

errado

correto

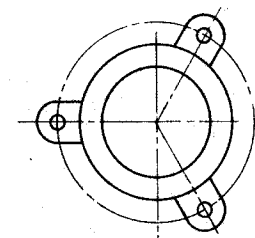

representação real

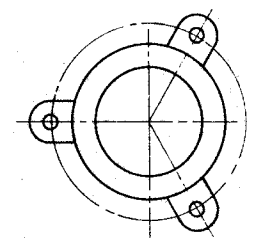

representação
convencional

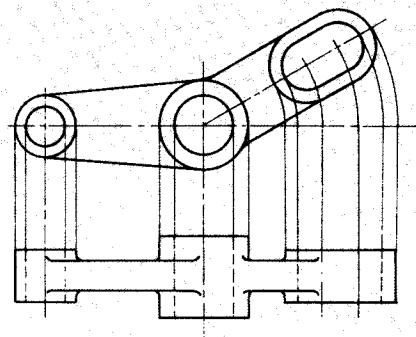

representação convencional

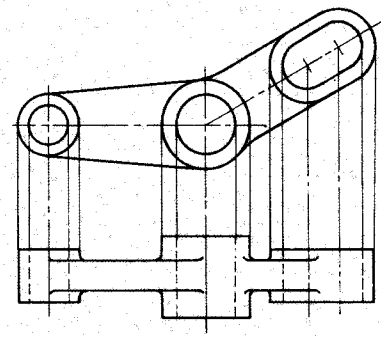

representação real

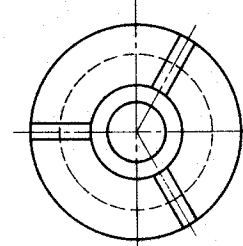

representação real

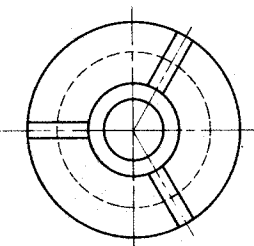

representação
convencional

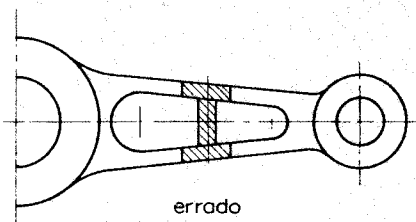

errado

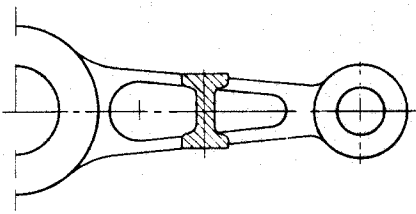

correto

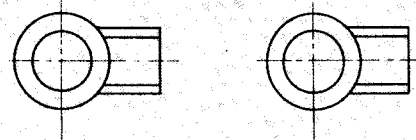

representação real

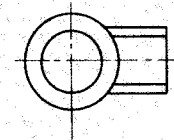

representação
simplificada

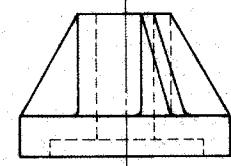

representação real

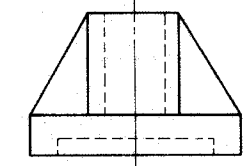

representação
convencional

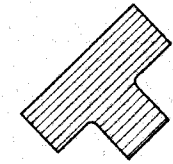

errado

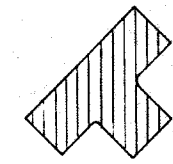

correto

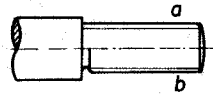

a) errado b) correto

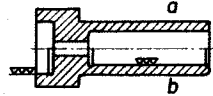

a) errado b) correto

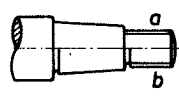

a) errado b) correto

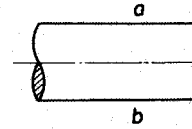

a) errado b) correto

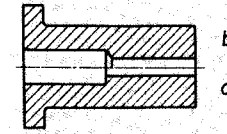

a) errado b) correto

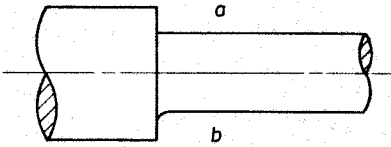

a) errado b) correto

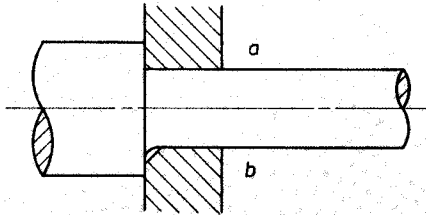

a) errado b) correto

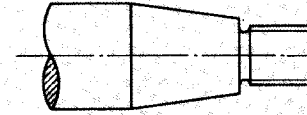

correto

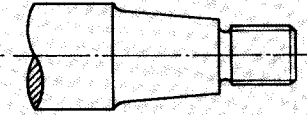

errado

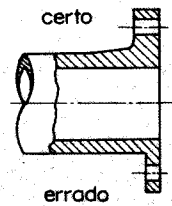

certo

errado

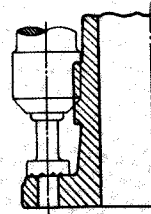

Deixar espaço suficiente
p/ trabalhos com fresa

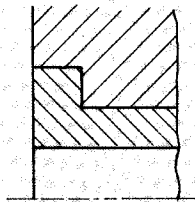

errado

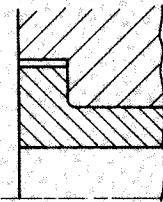

errado

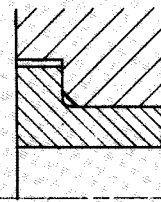

certo

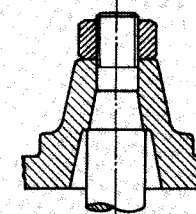

errado

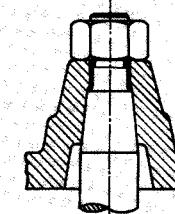

certo

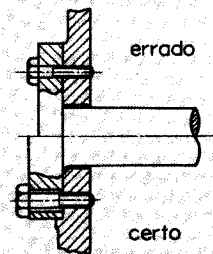

errado

certo

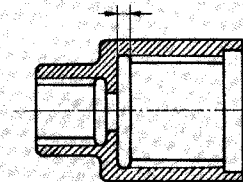

saída de roscas

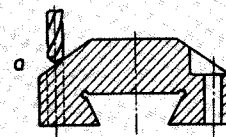
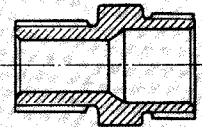

a) errado b) correto

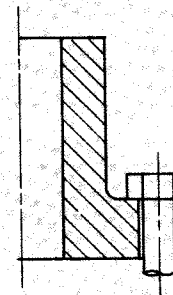

errado

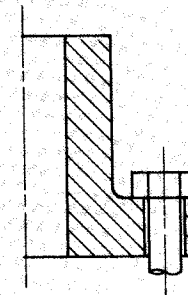

correto

TIPOS DE REFORÇOS

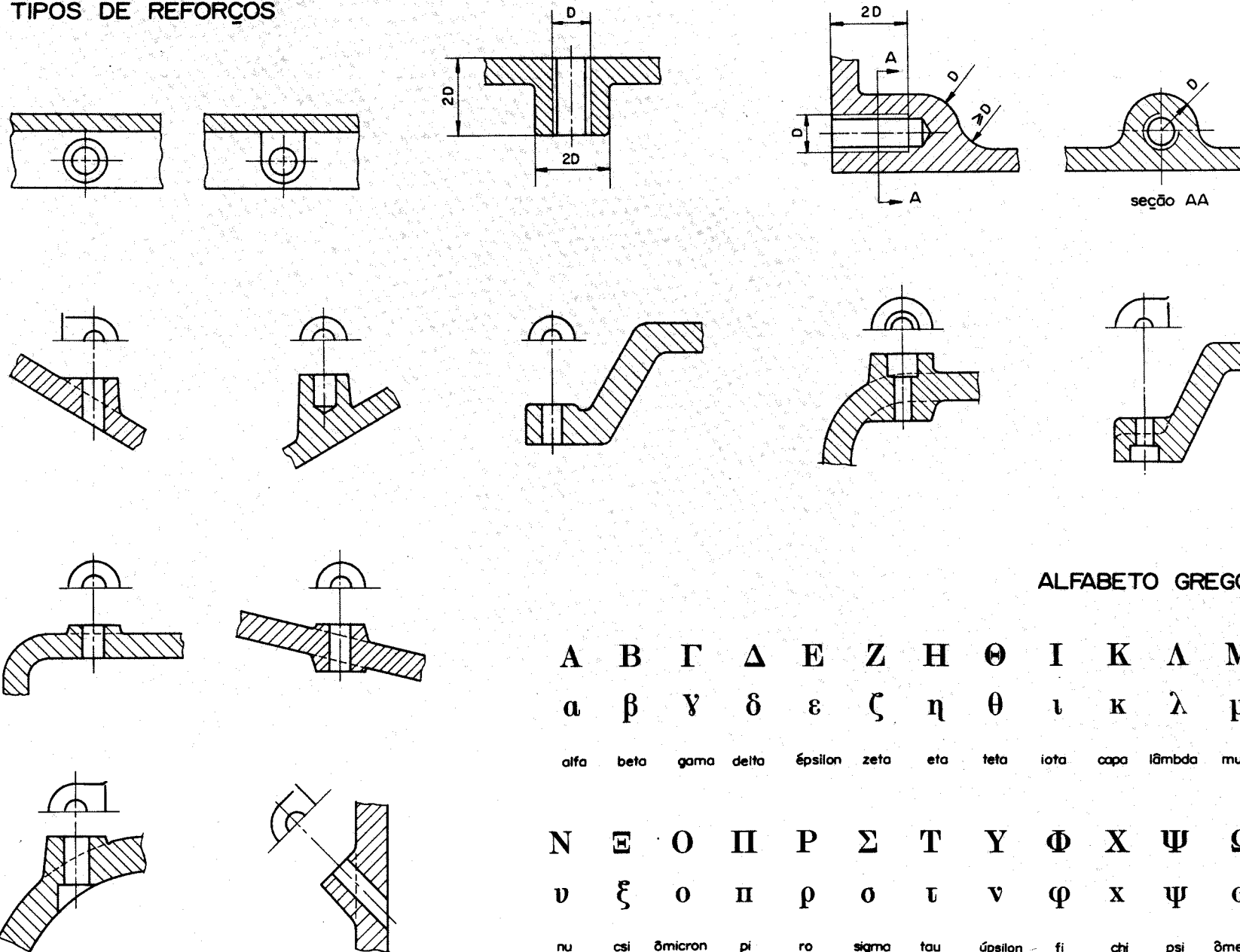

ALFABETO GREGO

A	B	Γ	Δ	E	Z	H	Θ	I	K	Λ	M
α	β	γ	δ	ε	ζ	η	θ	ι	κ	λ	μ
alfa	beta	gama	delta	épsilon	zeta	eta	teta	iota	capa	lâmbda	mu
N	Ξ	O	Π	P	Σ	T	Υ	Φ	X	Ψ	Ω
ν	ξ	ο	π	ρ	ο	τ	υ	φ	χ	ψ	ω
nu	csi	δmicron	pi	ro	sigma	tau	úpsilon	fi	chi	psi	δmega



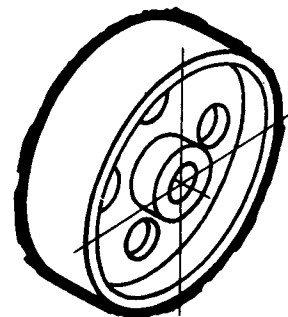
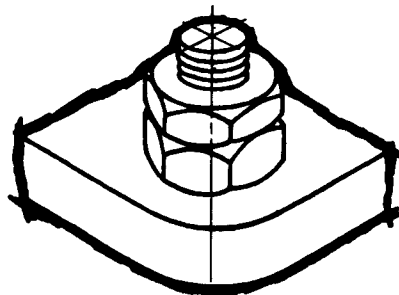
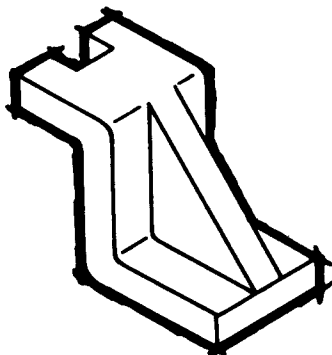
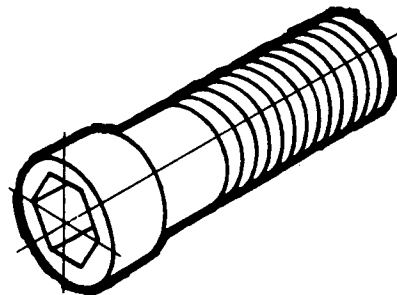
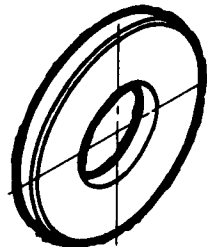
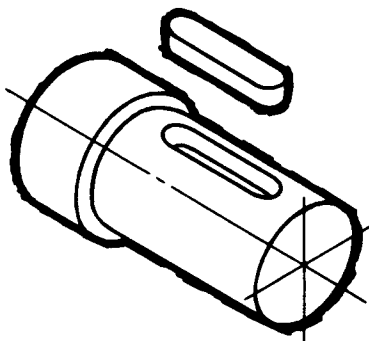
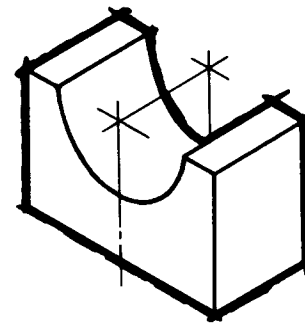
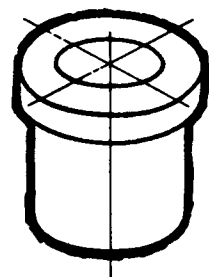
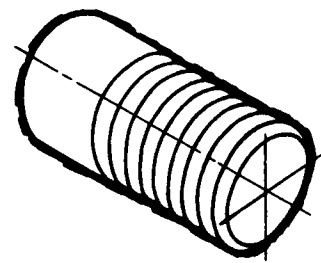

6 elementos de máquinas

glossário

rôscas

parafusos

porcas

pinos

chavetas

rebites

solda

polias

correntes

volantes

eixos

molas

rolamentos

engrenagens

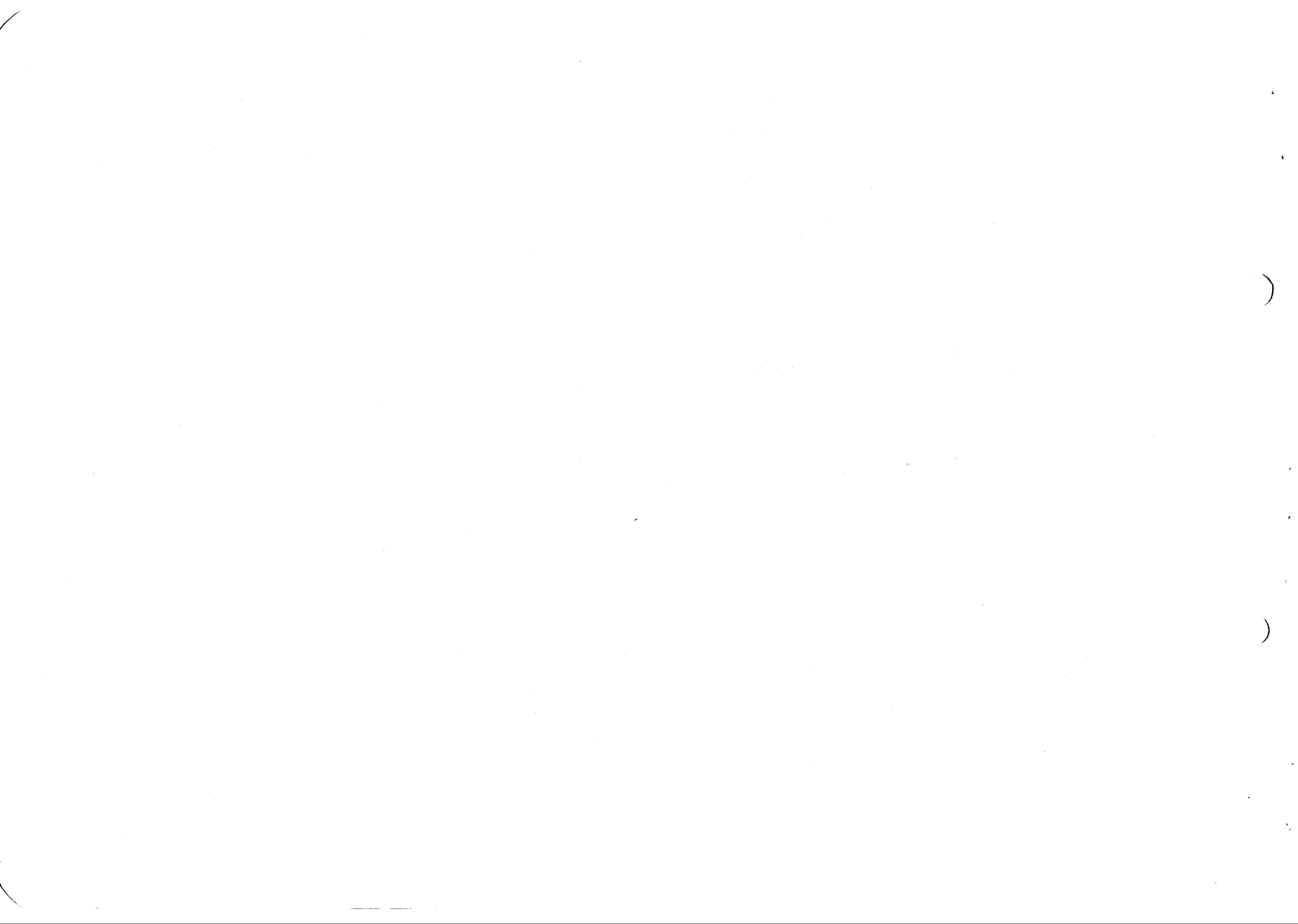

GLOSSÁRIO

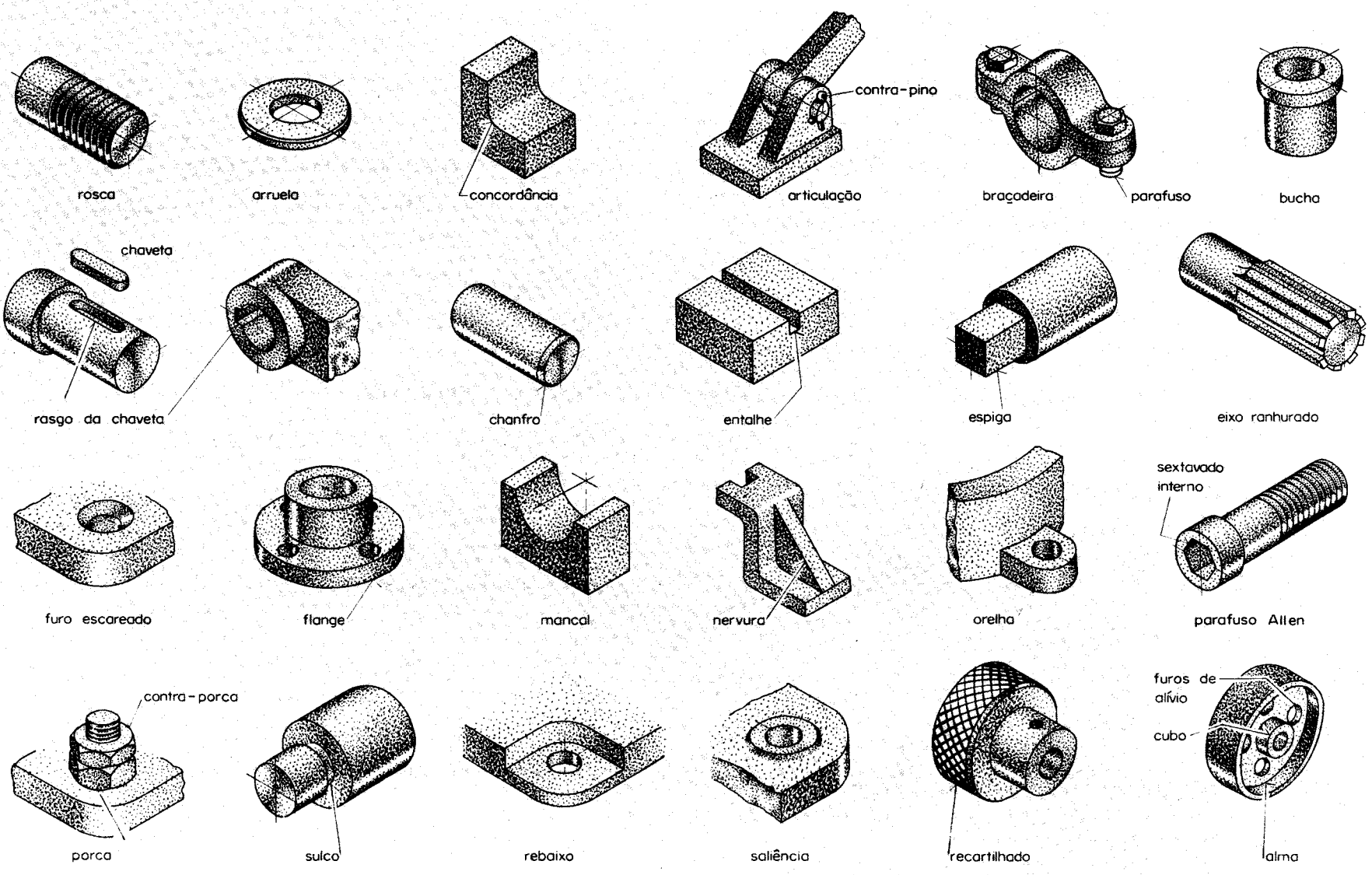

CLASSIFICAÇÃO DOS DESENHOS TÉCNICOS

Os desenhos técnicos se classificam segundo os critérios seguintes:

1- QUANTO AO ASPECTO GEOMÉTRICO

- a) Desenho projetivo: desenho resultante de projeções da peça sobre um ou mais planos, compreendendo as projeções ortogonais e as perspectivas.
- b) Desenho não projetivo: diagramas, esquemas, ábacos, nomogramas, fluxogramas, organogramas, gráficos, etc.

2- QUANTO AO GRAU DE ELABORAÇÃO

- a) Croquis: Representação gráfica expedita. Aplicada habitualmente aos estágios iniciais da elaboração de um projeto ou à representação de elementos existentes ou à execução de obra. É executado à mão livre ou com instrumentos.

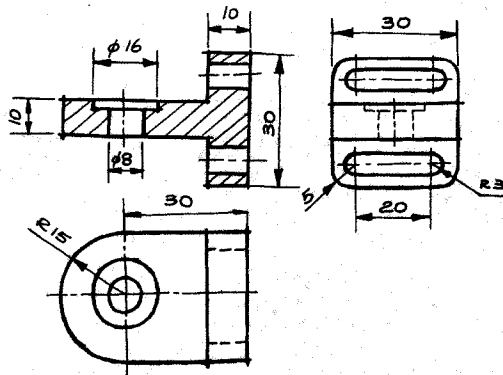

- b) Desenho preliminar: representação gráfica empregada nos estágios intermediários da elaboração do projeto, sujeito ainda a alterações. Corresponde ao ante-projeto.

- c) Desenho definitivo: desenho integrante da solução final do projeto, contendo os elementos necessários a sua compreensão, de modo a poder servir à execução.

3- QUANTO AO GRAU DE PORMENORIZAÇÃO

- a) Conjunto: desenho mostrando reunidos vários componentes, que se associam para formar um todo.
- b) Subconjunto: parte de um conjunto.
- c) Detalhe: desenho de componente isolado de um todo.

4- QUANTO A FINALIDADE

- a) Fabricação b) Montagem c) Ilustração

5- QUANTO AO MATERIAL EMPREGADO

- a) à lapis b) à tinta
- em papel comum ou transparente

6- QUANTO À TÉCNICA DE EXECUÇÃO

- a) à mão livre b) com instrumentos

7- QUANTO À NATUREZA

- a) Original
- b) Cópia: heliográfica, fotográfica (ampliação, redução), etc.

SEQUÊNCIA DO TRAÇADO DE CONCORDÂNCIAS

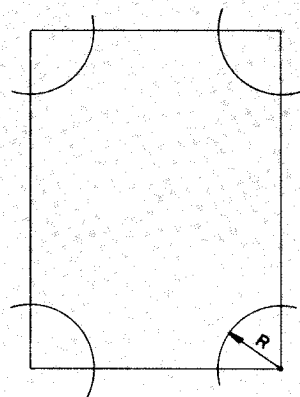

1ª etapa

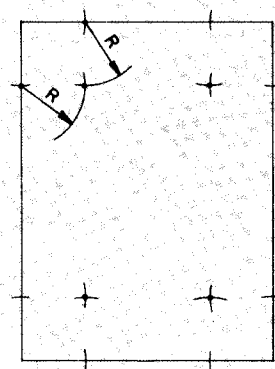

2ª etapa

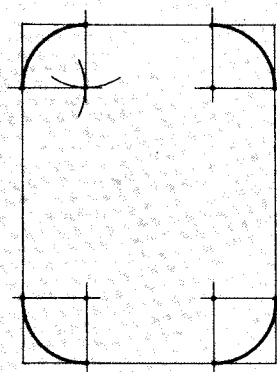

3ª etapa

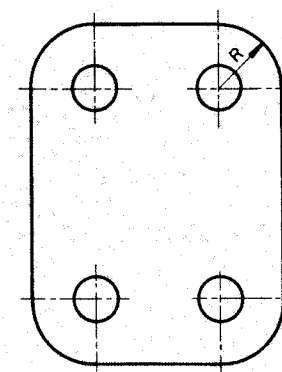

4ª etapa

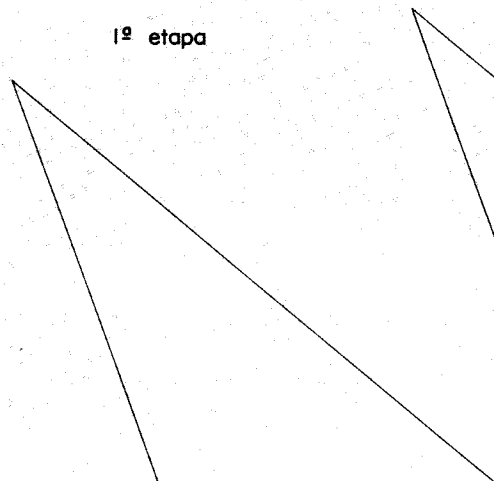

1ª etapa

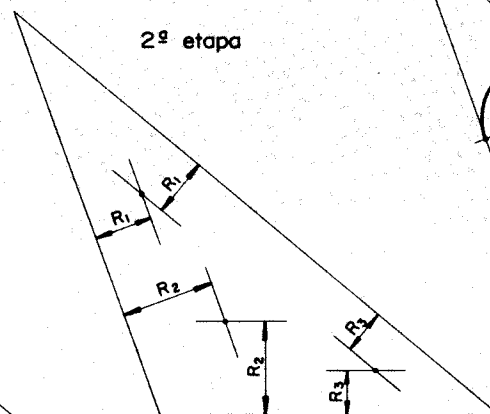

2ª etapa

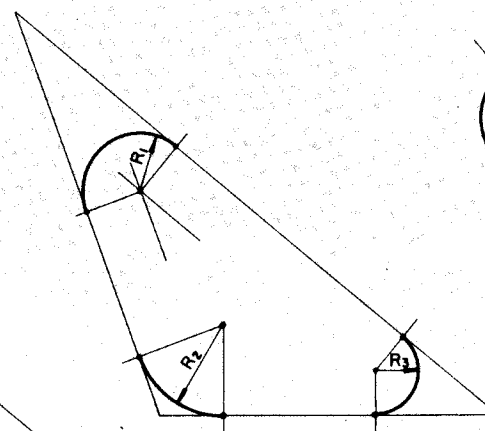

3ª etapa

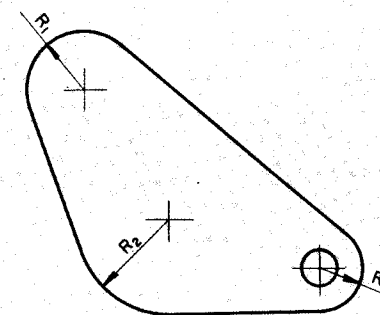

4ª etapa

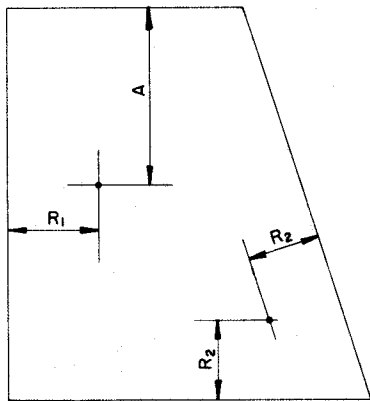

1ª etapa

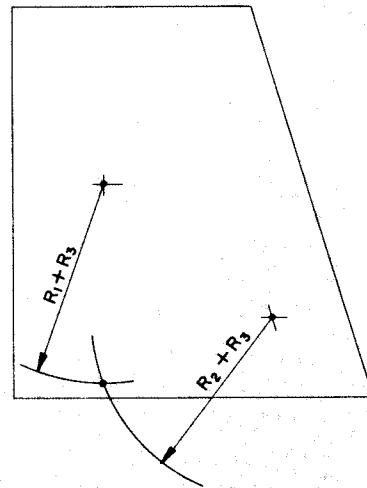

2ª etapa

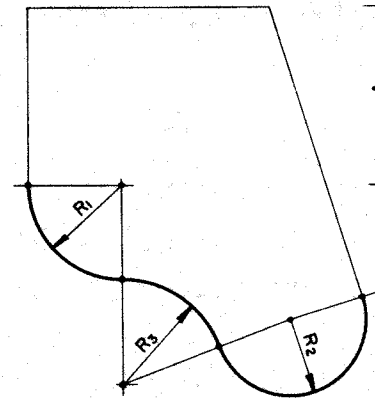

3ª etapa

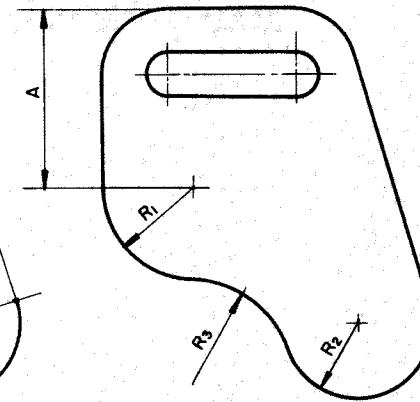

4ª etapa

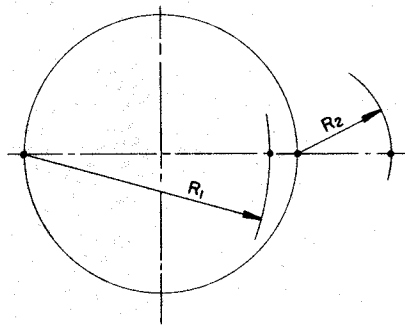

1ª etapa

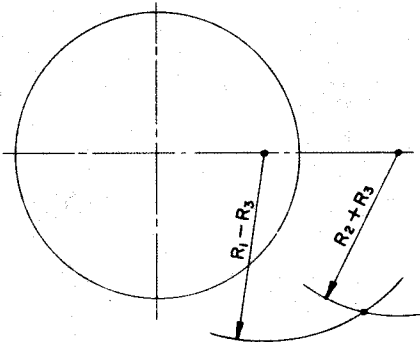

2ª etapa

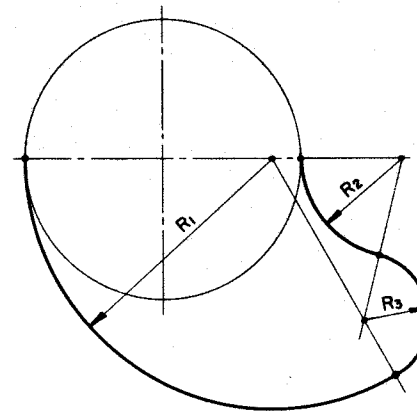

3ª etapa

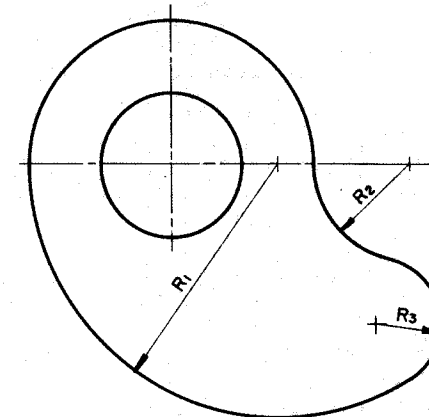

4ª etapa

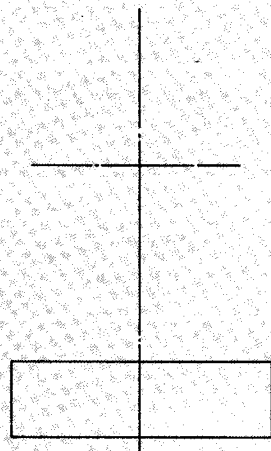

1ª etapa

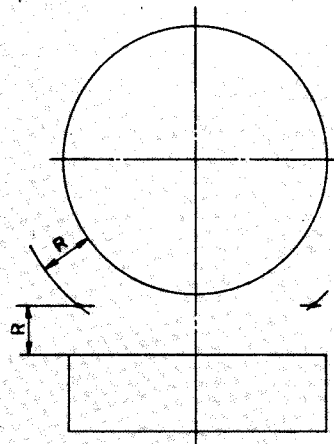

2ª etapa

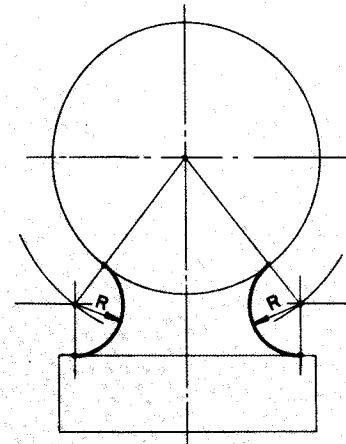

3ª etapa

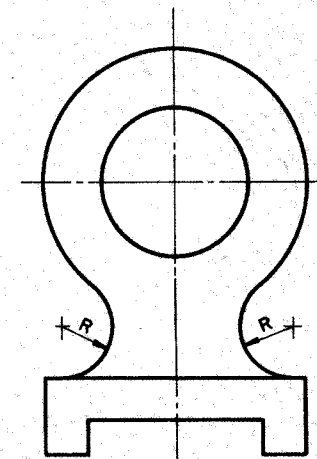

4ª etapa

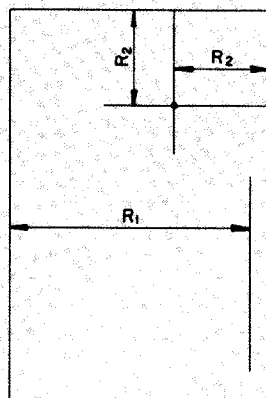

1ª etapa

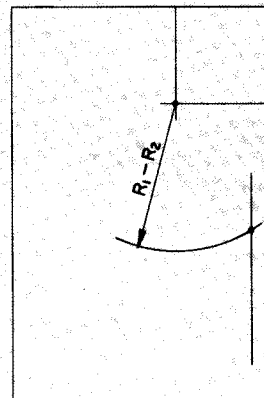

2ª etapa

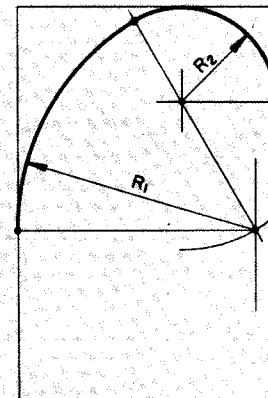

3ª etapa

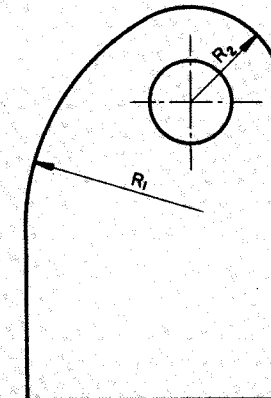

4ª etapa

SEQUÊNCIA DO TRAÇADO DE DESENHO A LAPIS

1ª etapa:
escolher as vistas

2ª etapa:
estabelecer a escala

3ª etapa:
dispor mentalmente as vistas, visando obter uma aparência bem equilibrada sobre o papel.

6ª etapa: traçar as concordâncias, os arcos e as circunferências com grafite HB.

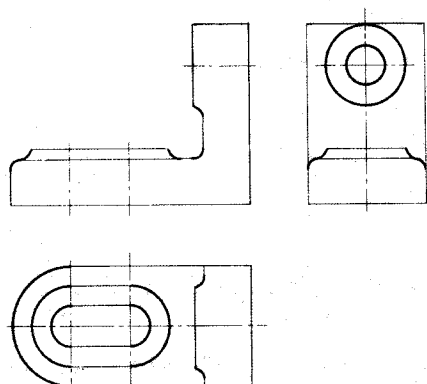

4ª etapa: traçar as linhas de centro com lápis F.

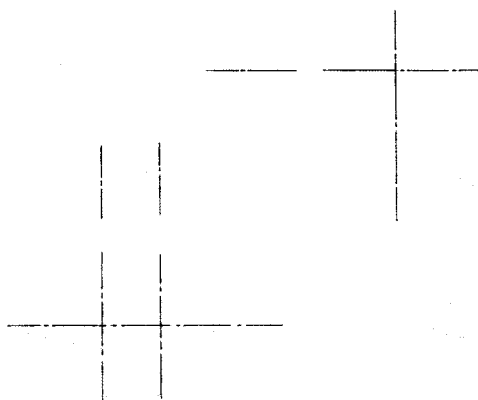

7ª etapa: reforçar o desenho com lápis HB e hachurar com lápis F.

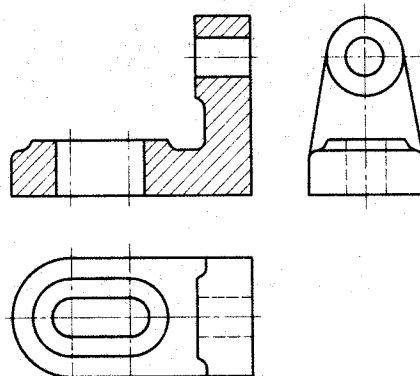

5ª etapa: traçar o contorno com lápis F.

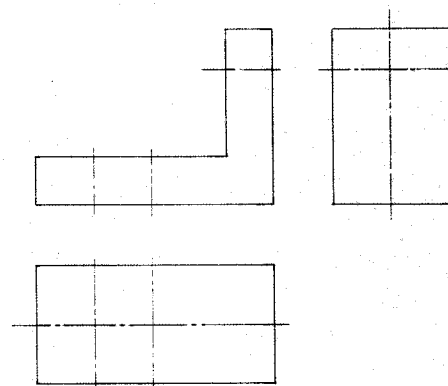

8ª etapa: colocar as cotas e as observações com lápis HB.

9ª etapa: fazer a verificação final.

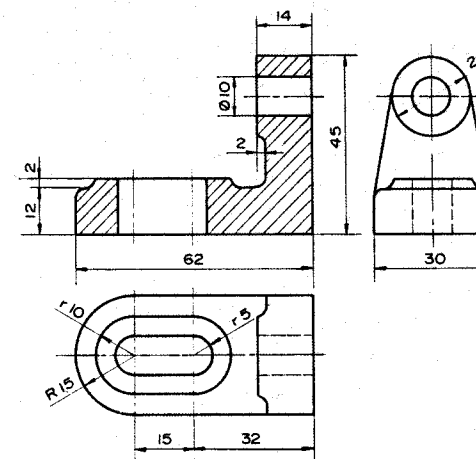

SEQUÊNCIA DO TRAÇADO DE DESENHO A TINTA

1ª etapa : fixar o papel vegetal sobre o desenho a lápis.
Passar a borracha para remover a gordura do papel vegetal

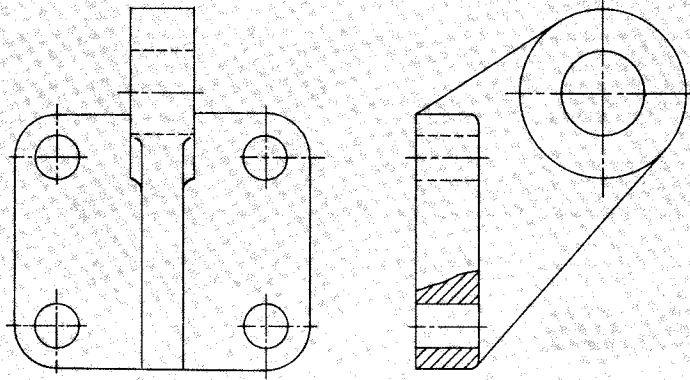

2ª etapa : passar a tinta com traço grosso começando pelos arcos e circunferências.

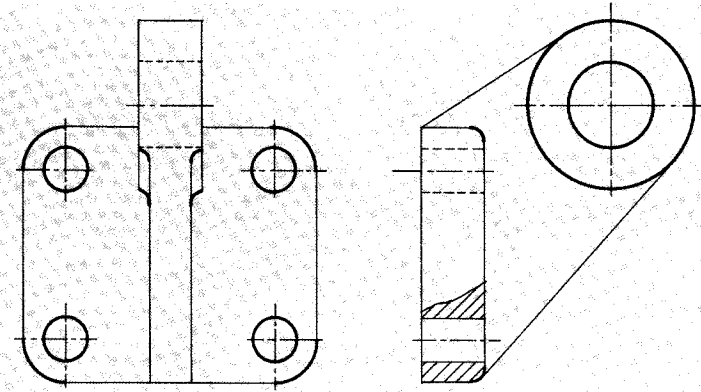

3ª etapa : passar a tinta o restante do contorno com traço grosso.

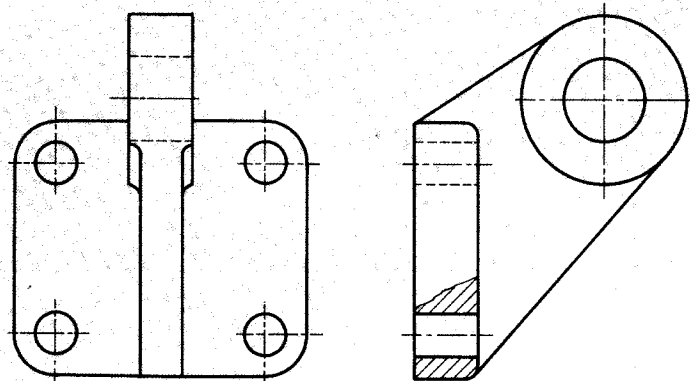

4ª etapa : passar a tinta as linhas de centro, hachuras, linhas de chamada e de cota com traço fino. Cotar o desenho.

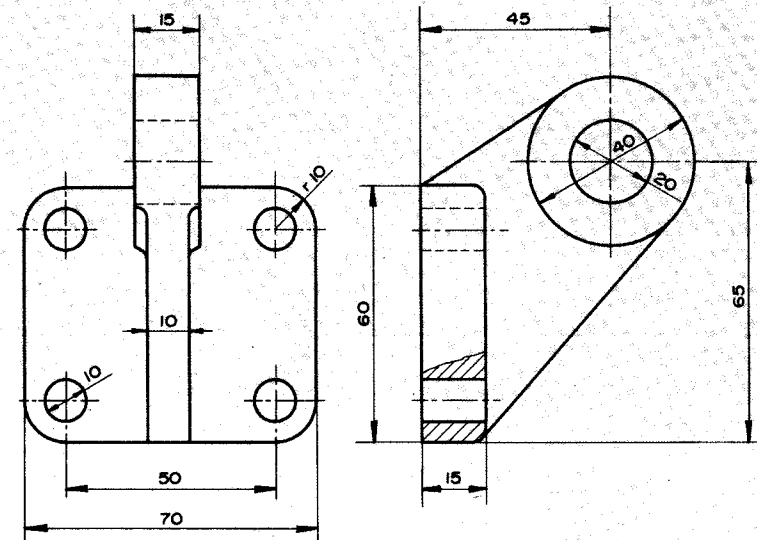

Normalmente são usadas para traço grosso pena 0,4 e para traço fino pena 0,1.

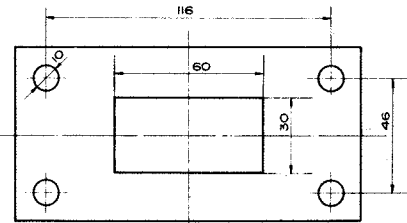
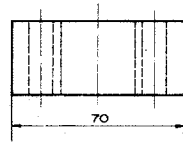
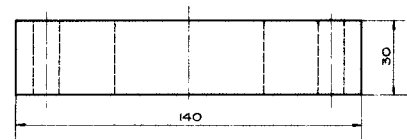

bloco de guia
 material: aço NB 1040

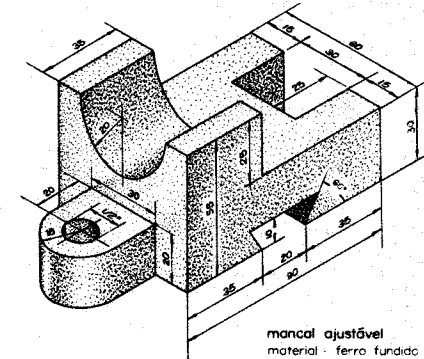
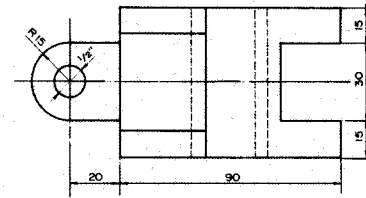
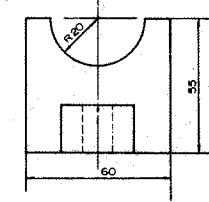
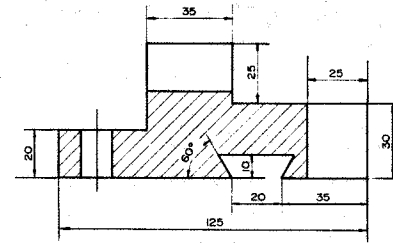
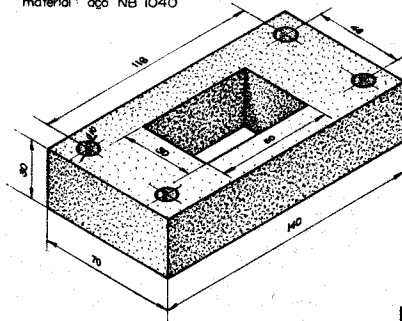

mancal ajustável
 material: ferro fundido

EXEMPLOS

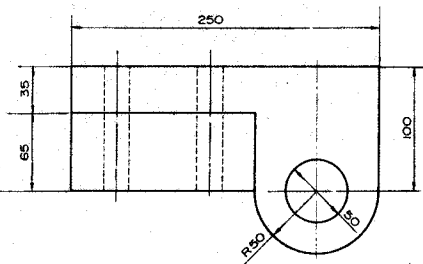
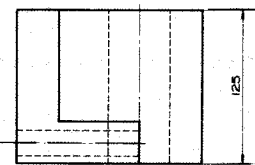
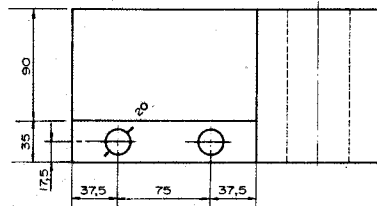

suporte
 material: ferro fundido

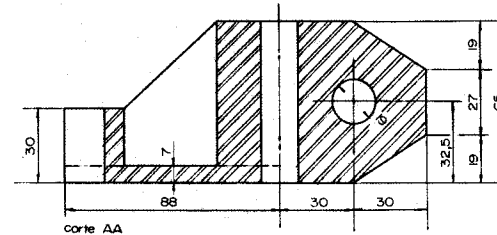
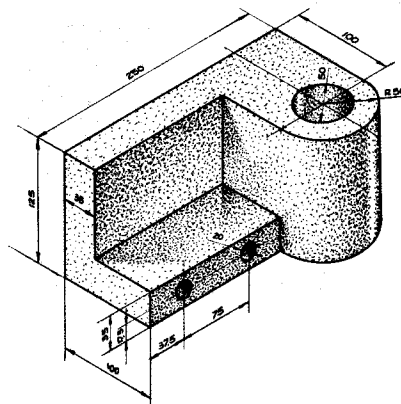

corte AA

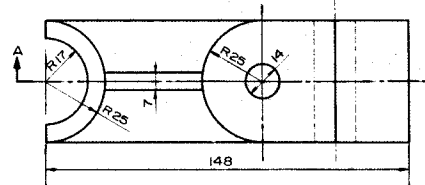

encosto
 material: aço AF 3525

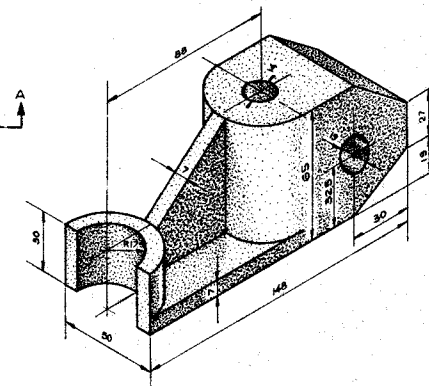

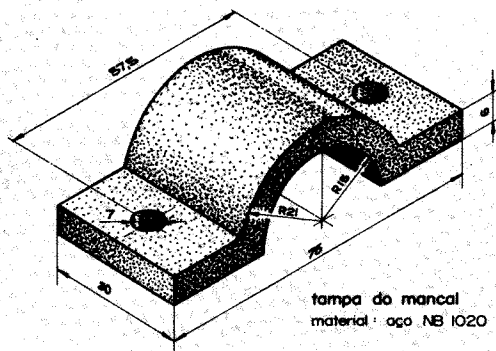
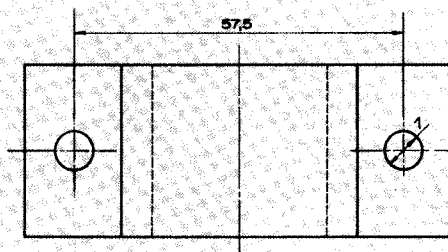
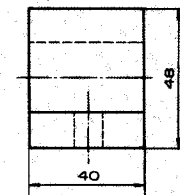
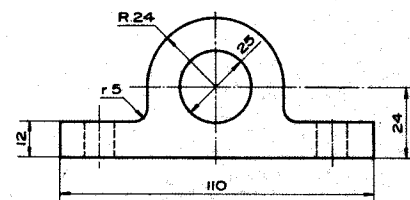
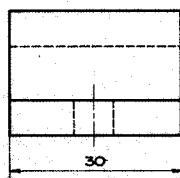
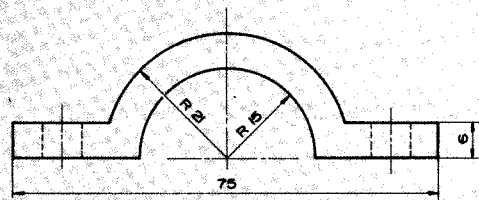

tampa do mancal
material: aço NB 1020

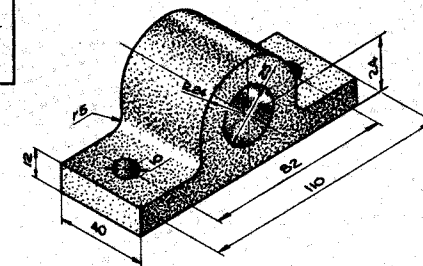
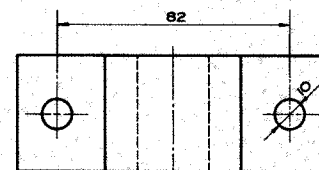

mancal de escorregamento
material: ferro fundido

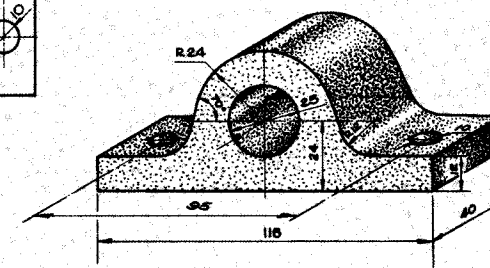
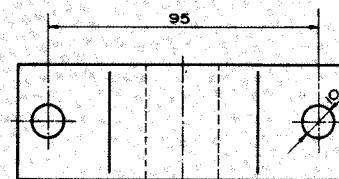
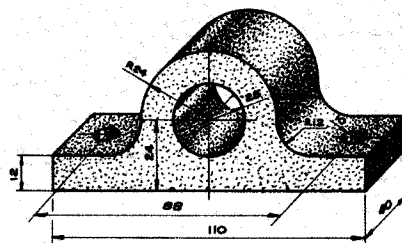
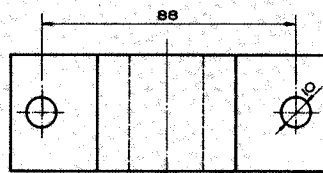
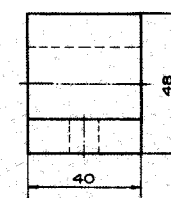
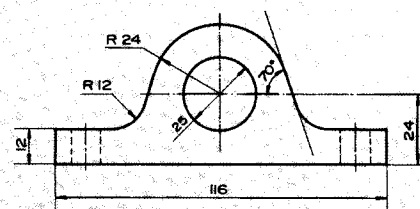
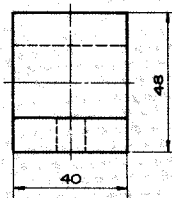
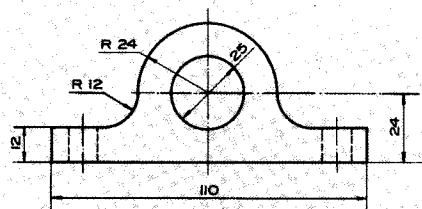

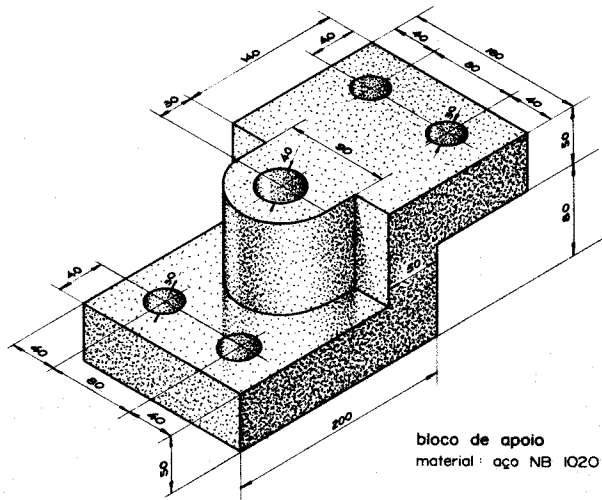

bloco de apoio
 material: aço NB 1020

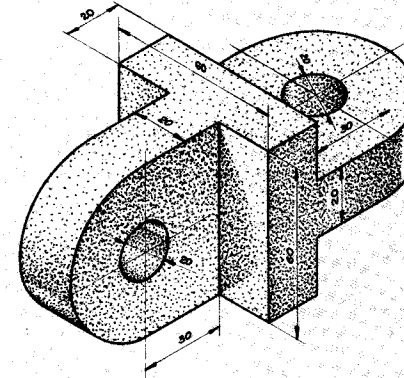
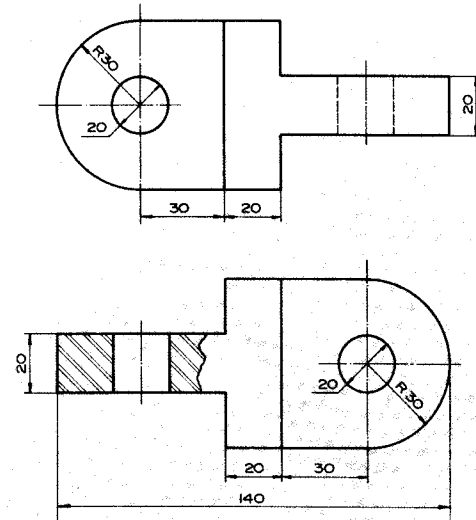

tirante em cruz
 material: ferro forjado

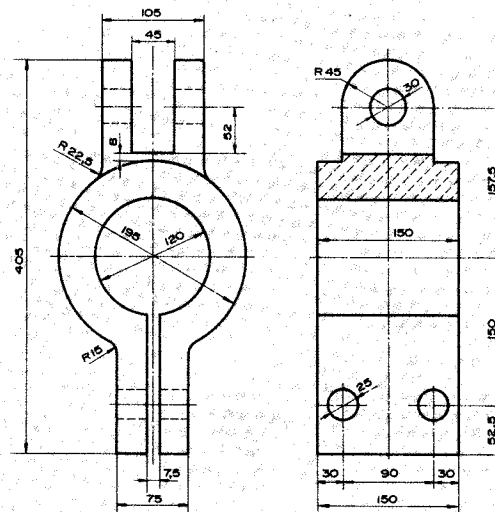
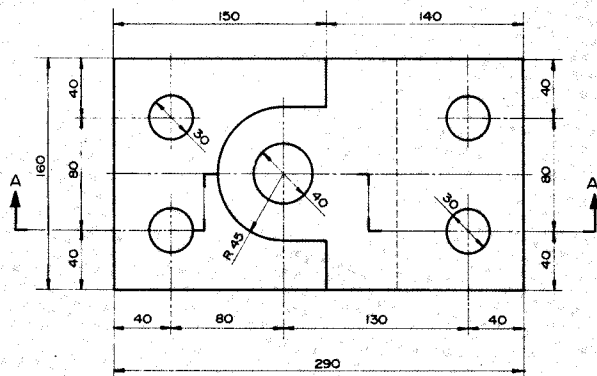
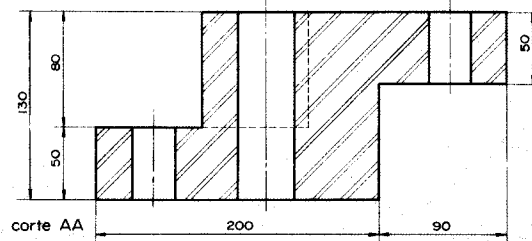

braçadeira
 material: alumínio

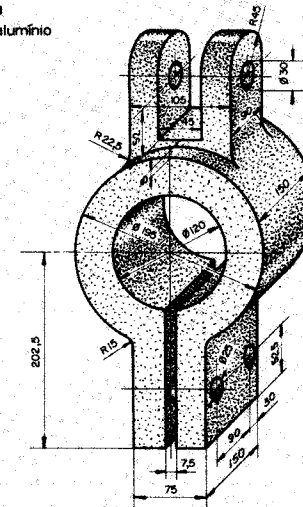

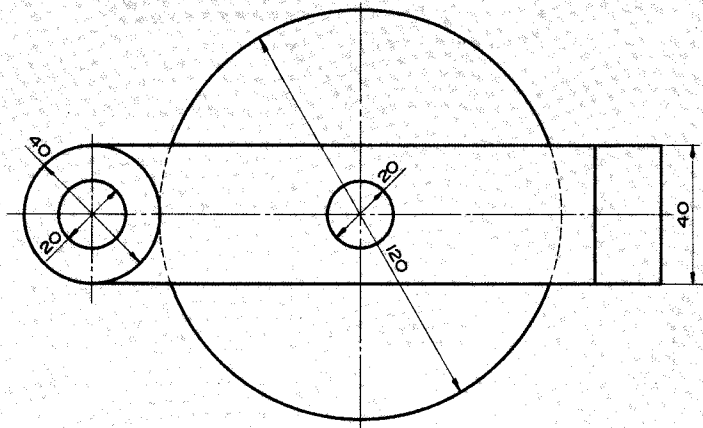
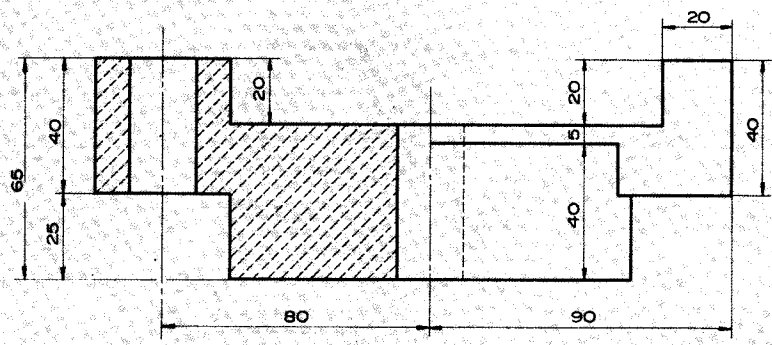

terminal
material: alumínio

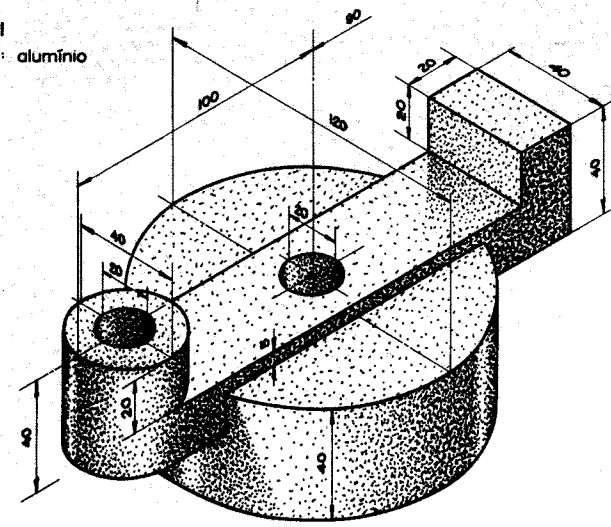

suporte duplo
material: aço NB 1020

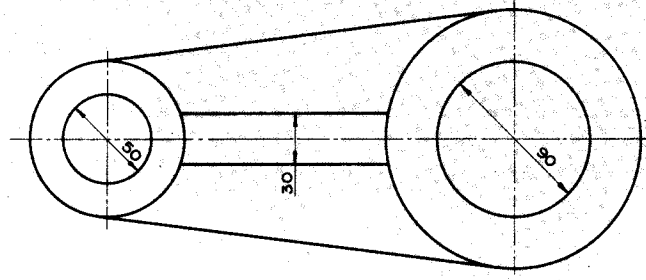
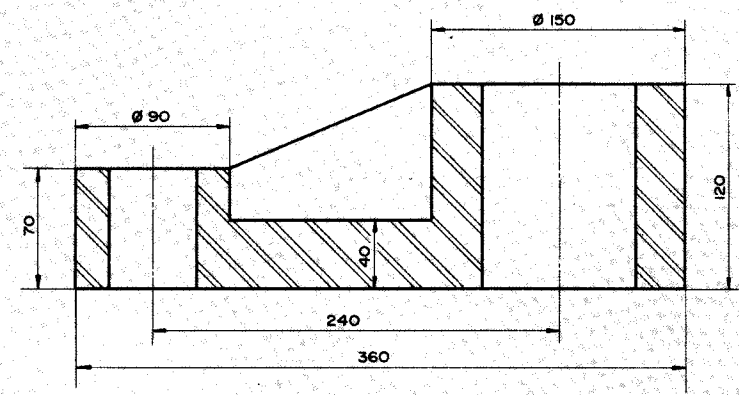
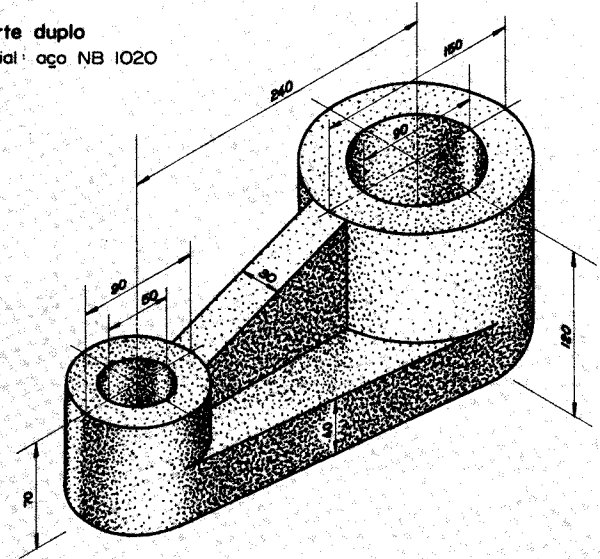

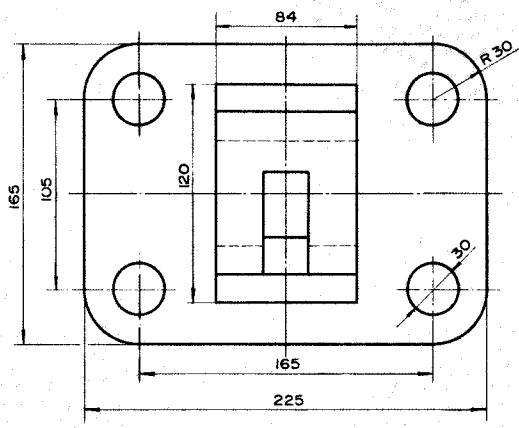
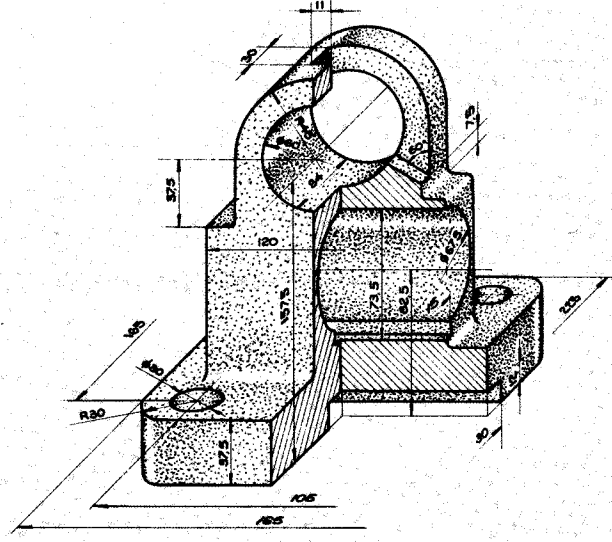
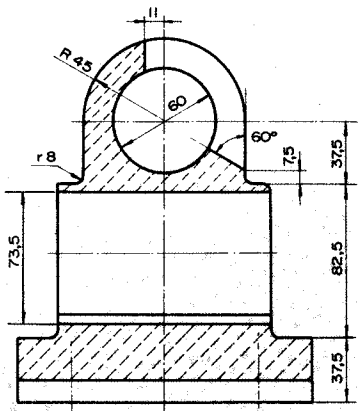
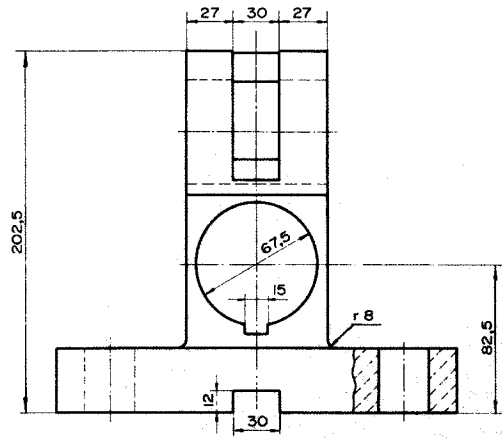

suporte de eixo
 material : alumínio

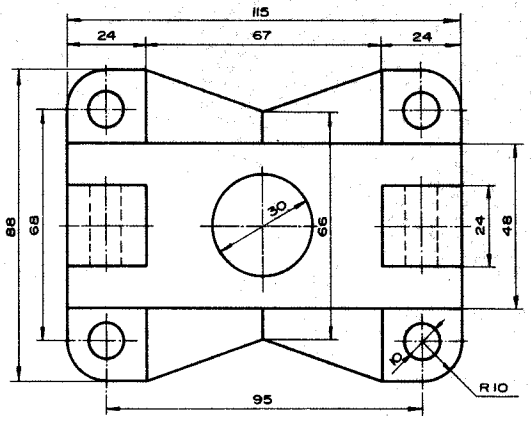
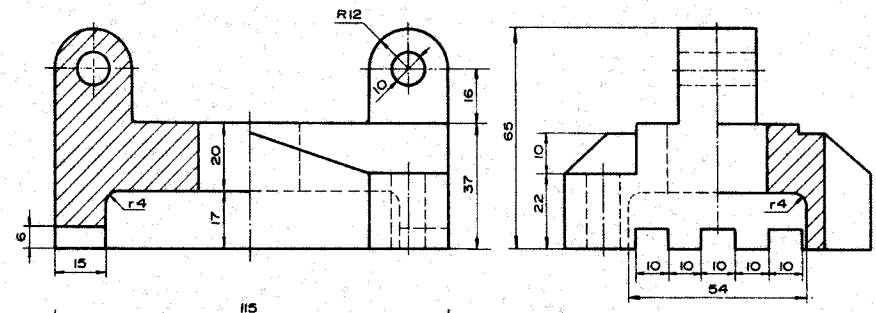

base
 material : ferro fundido

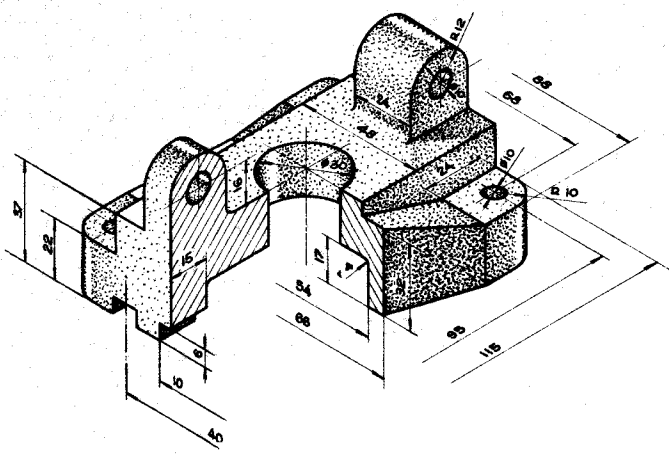

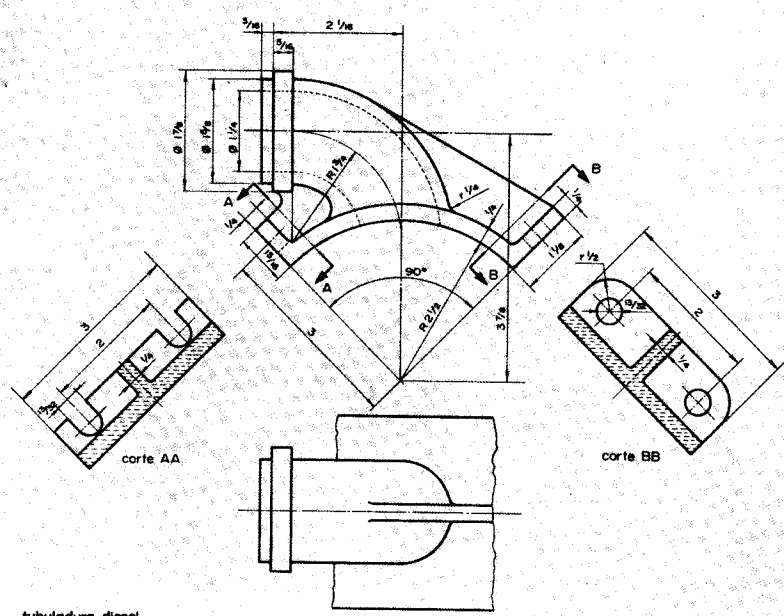

tubuladura diesel
material: magnésio
unidade: polegada

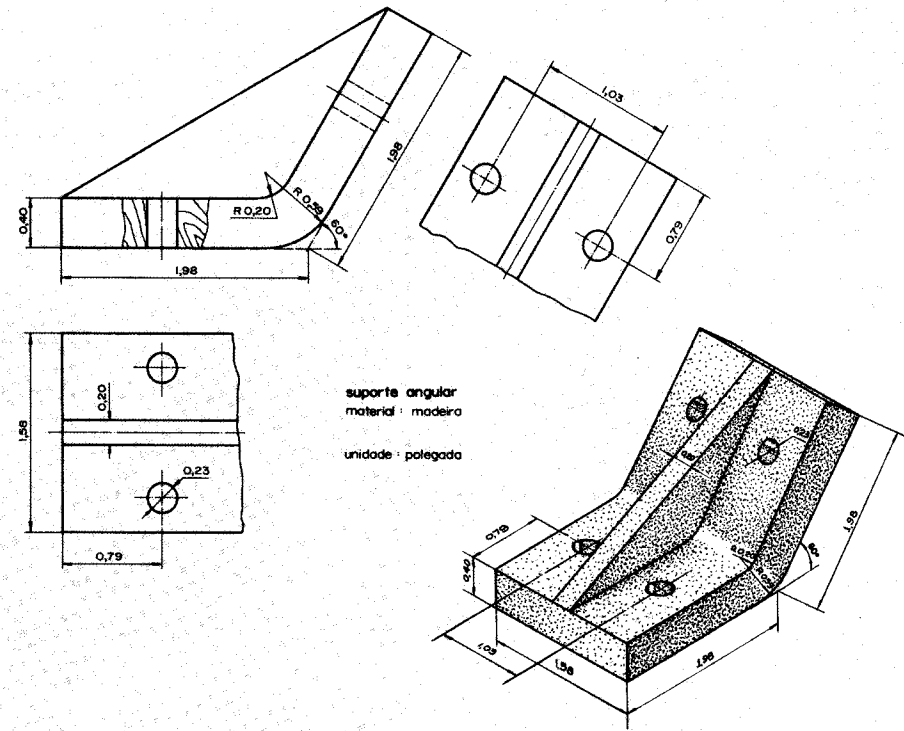

suporte angular
material: madeira
unidade: polegada

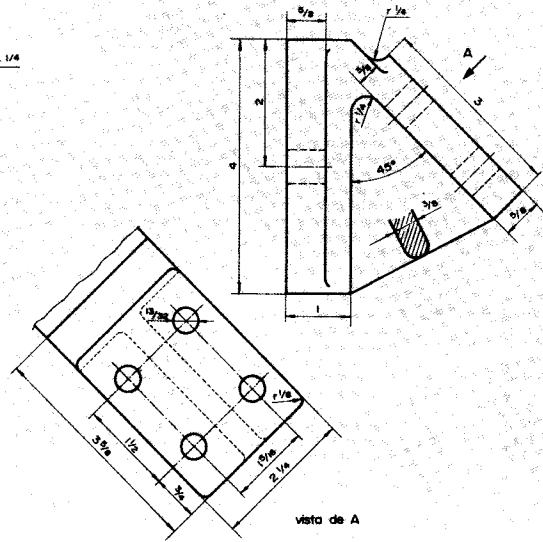
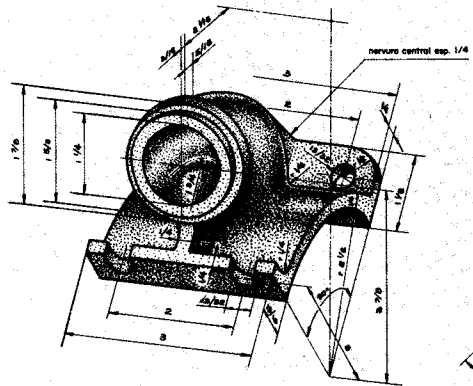

vista de A

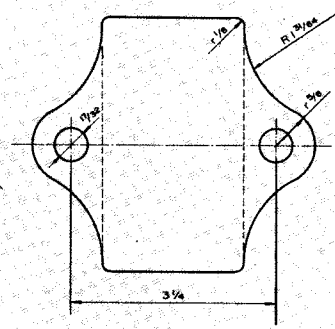

base angular
material: ferro fundido
unidade: polegada

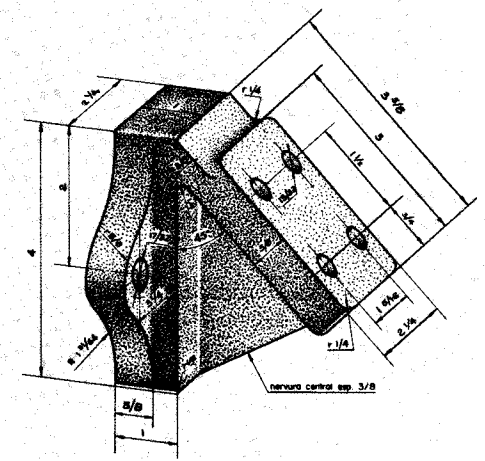

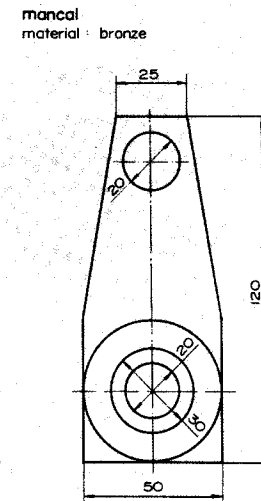
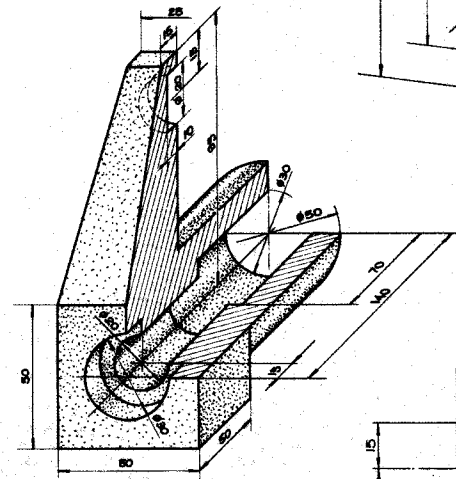
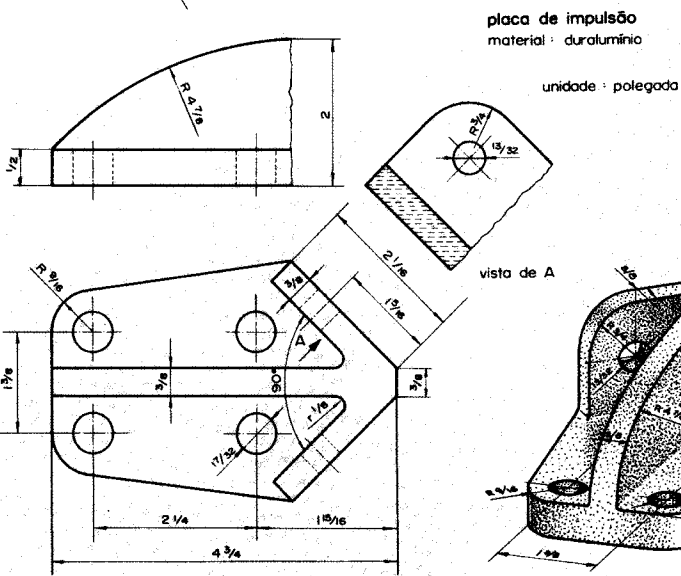
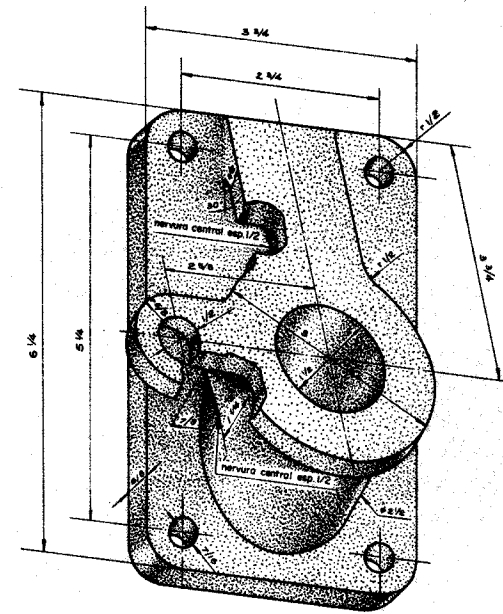
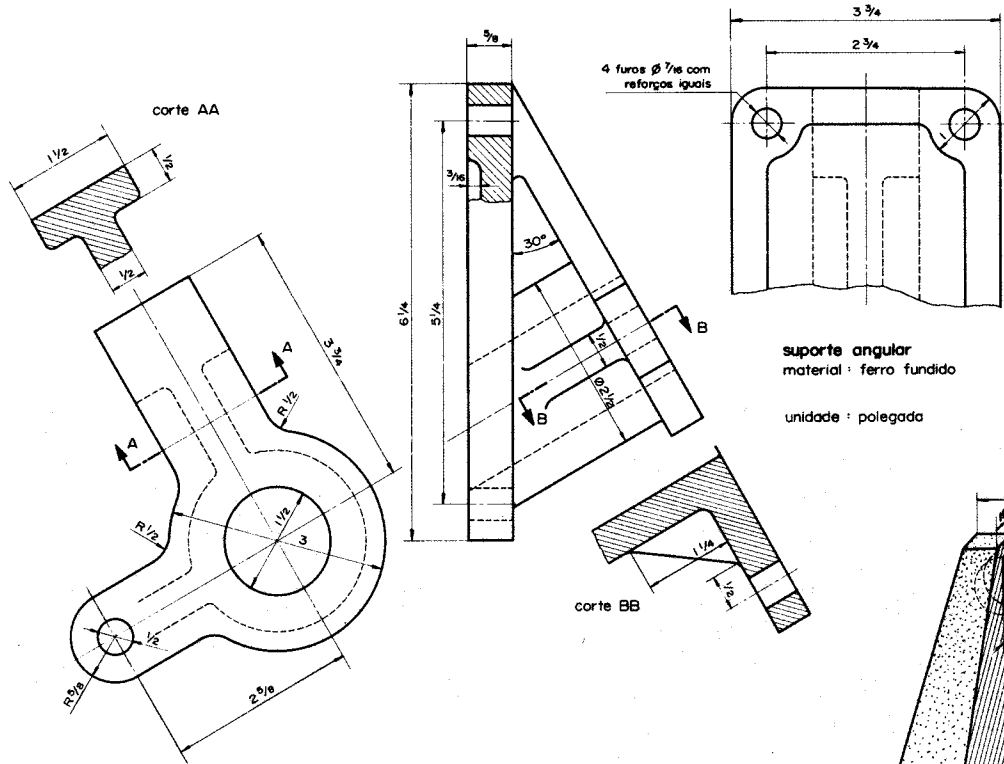

TIPOS DE ROSCAS

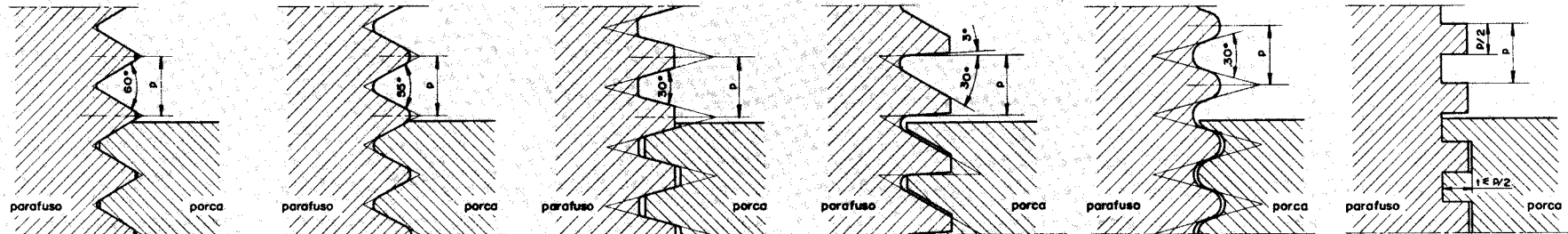

rosca métrica

rosca whitworth

rosca trapezoidal

rosca dente de serra

rosca de filête arredondado

rosca quadrada

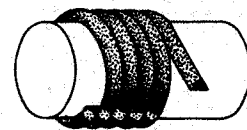
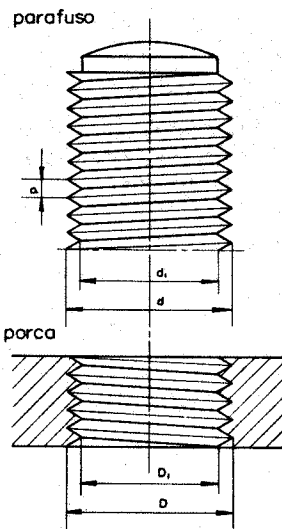

rosca triangular



rosca trapezoidal

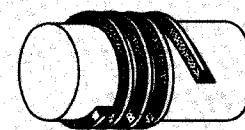

rosca dente de serra



rosca com 2 entradas

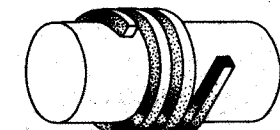

rosca quadrada à esquerda

LEGENDA

- p = passo
- d = diâmetro indicativo da rosca
(diâmetro externo do parafuso)
- d₁ = diâmetro interno do parafuso
- D = diâmetro externo da rosca da porca
- D₁ = diâmetro do furo da porca

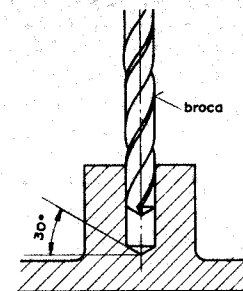

Furação

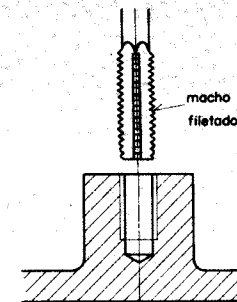

Abertura da rosca

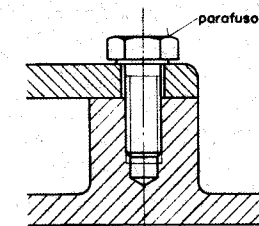

Montagem

INDICAÇÃO DAS ROSCAS

ROSCAS ã DIREITA COM UMA ENTRADA			
Tipo	Símbolo	Medidas	Exemplo
Whitworth normal	—	Diâm. ext. da rosca em pol.	2"
Whitworth fina	W	Diâm. ext. em mm e passo em pol.	W 84 x 1/8"
Whitworth de tubos	R	Diâm. nominal do tubo em pol.	R 4"
Métrica normal	M	Diâm. ext. da rosca em mm.	M 80
Métrica fina	M	Diâm. ext. da rosca em mm e passo em mm.	M 104 x 4
Trapezoidal	Tr	Diâm. ext. da rosca em mm e passo em mm.	Tr 48 x 8
Redonda	Rd	Diâm. ext. da rosca em mm e passo em pol.	Rd 40 x 1/8"
Dentes de serra	S	Diâm. ext. da rosca em mm e passo em mm.	S 70 x 10
Edison	E	Diâm. nominal em mm.	E 27

ROSCAS ã ESQUERDA OU COM VÁRIAS ENTRADAS			
Tipo da rosca	Abreviatura	Exemplos	Válido para
Gás e vapor	gás	M 20 gás 2" gás	Métrica, Whitworth e Whitworth de tubos
Esquerda	esq.	W 104 x 1/8" esq. M 80 esq.	Whitworth Métrica
Várias entradas ã direita	(i ent.)	2" (2 ent.) Tr 48 x 16 (2 ent.)	Trapezoidal Redonda
Várias entradas ã esquerda	esq. (i ent.)	M 10 esq. (2 ent.) Tr 48 x 16 esq. (2 ent.)	Dentes de serra

Parafuso

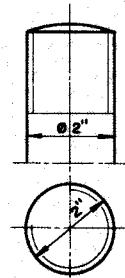

Parafuso com rosca Whitworth normal de diâm. 2"

Parafuso

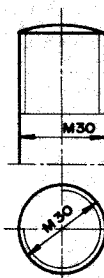

Parafuso com rosca Métrica normal de diâm. 30mm

Furo roscado passante

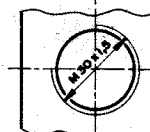
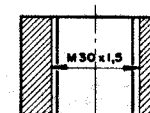

Rosca métrica fina de diâm. 30mm e passo 1,5mm.

Furo roscado cego

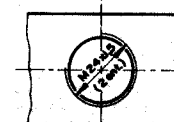
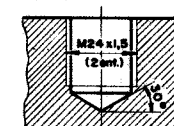

Rosca métrica a duas entradas de diâm. 24mm e passo 1,5mm.

As roscas quadradas têm a seguinte indicação:

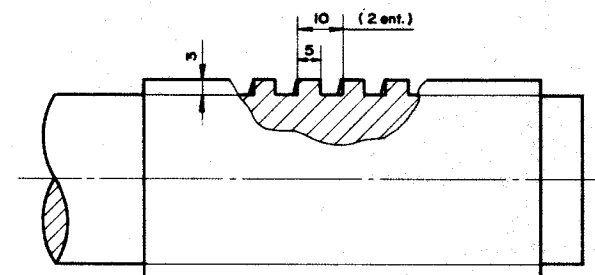

TRAÇADO DE ROSCAS

TRAÇADO EXATO DE UMA ROSCA

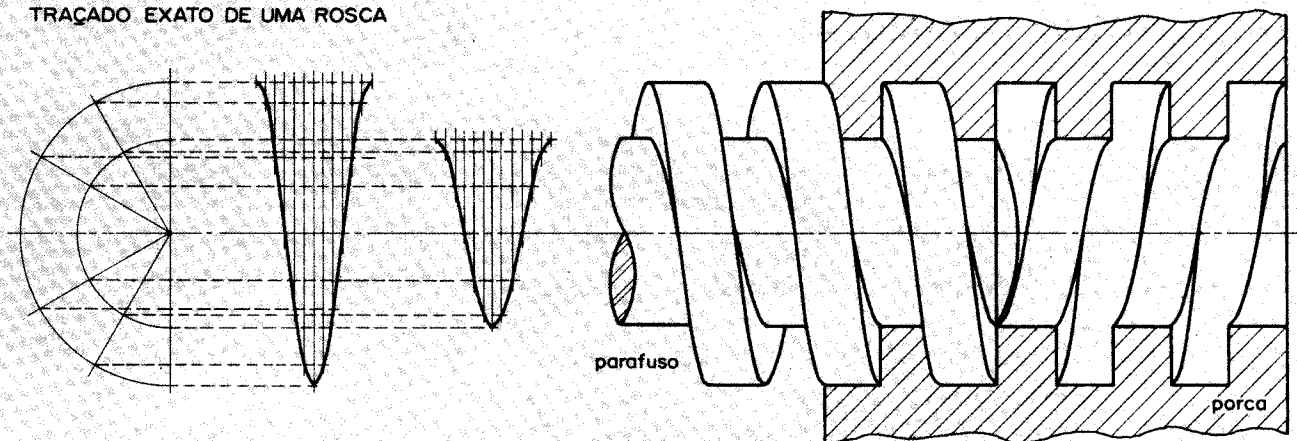

Observar a diferença entre o traçado do parafuso e da porca.

O traçado exato de uma rosca é raramente empregado nos desenhos a não ser em roscas de grandes diâmetros. Para casos comuns deve-se usar o traçado simplificado como nas figuras abaixo.

ROSCA QUADRADA COM UMA ENTRADA À DIREITA

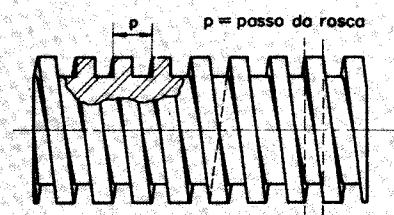

ROSCA TRAPEZOIDAL COM DUAS ENTRADAS À DIREITA

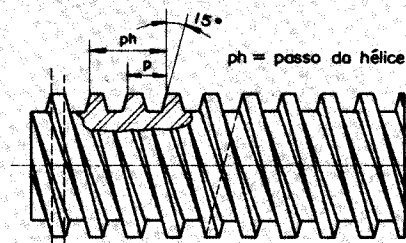

REPRESENTAÇÃO SIMPLIFICADA DE UMA ROSCA QUADRADA

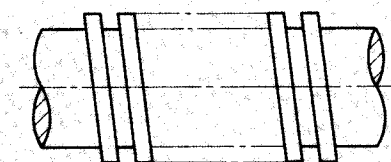

ROSCA QUADRADA COM UMA ENTRADA À ESQUERDA

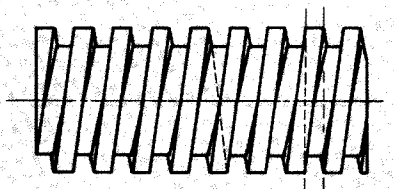

ROSCA TRAPEZOIDAL COM TRÊS ENTRADAS À DIREITA

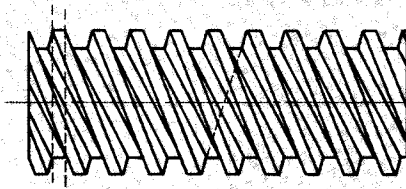

UMA ENTRADA

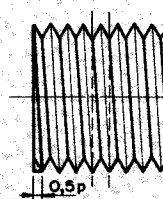

DUAS ENTRADAS

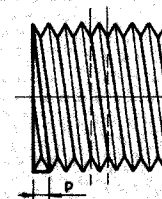

TRÊS ENTRADAS

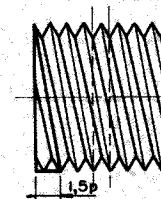

Observar pelas linhas tracejadas, perpendiculares à linha de centro do parafuso que nas roscas com número par de entradas o dente de um lado coincide com o dente do lado oposto e nas roscas com número ímpar de entradas, o dente de um lado coincide com o vão do lado oposto.

SEQUÊNCIA DO TRAÇADO DE ROSCAS

ROSCA TRIANGULAR

parafuso

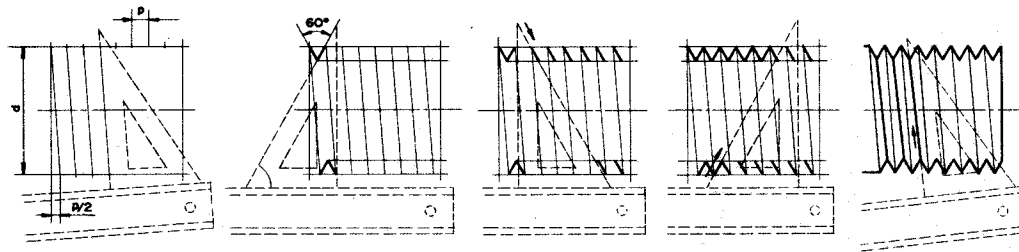

porca

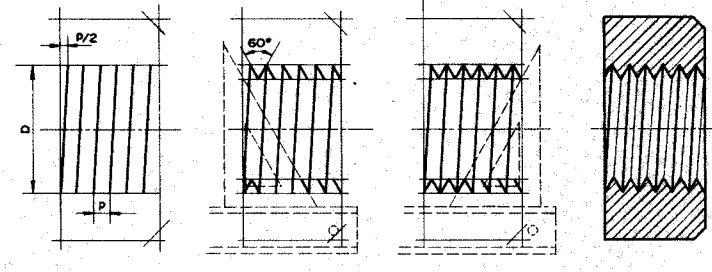

parafuso

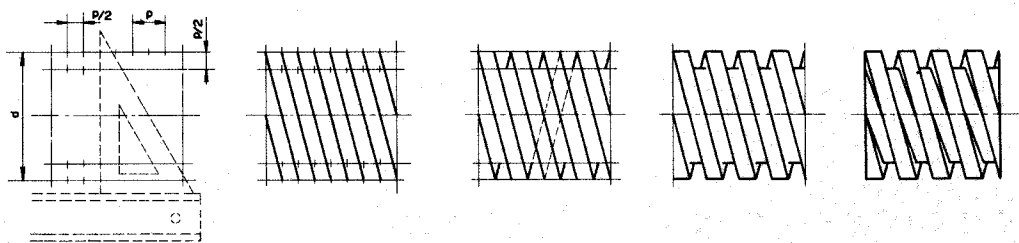

ROSCA QUADRADA

porca

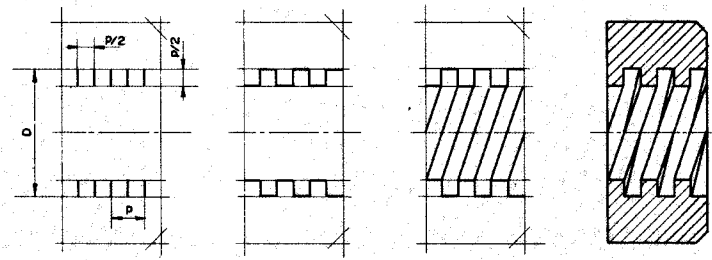

parafuso

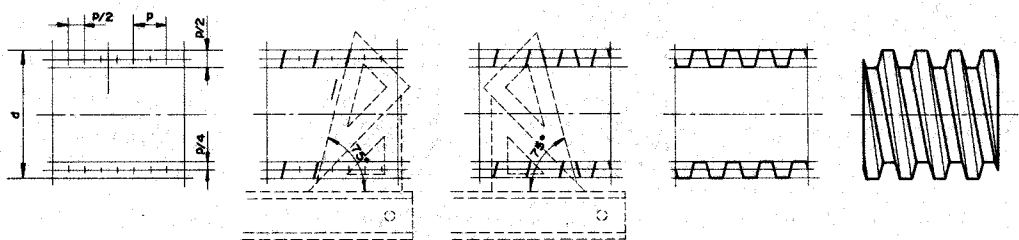

ROSCA TRAPEZOIDAL

porca

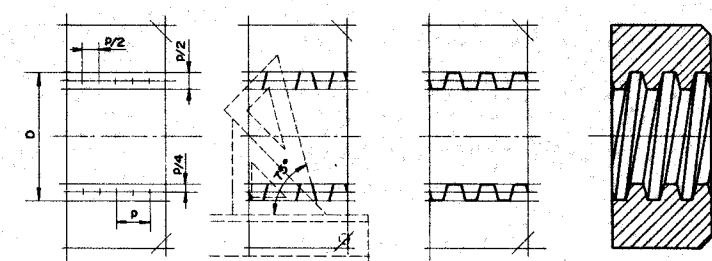

APLICAÇÃO DE ROSCAS

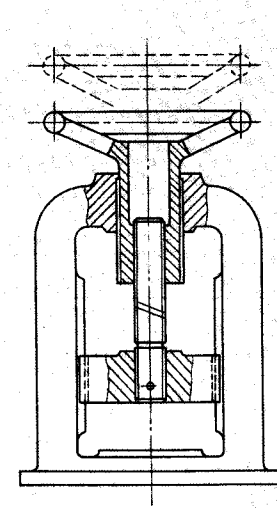
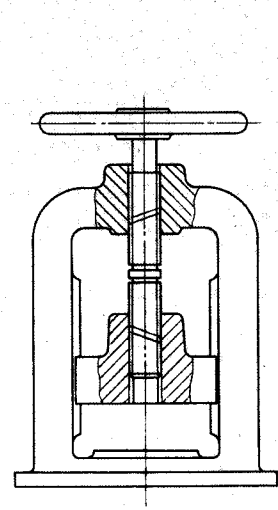
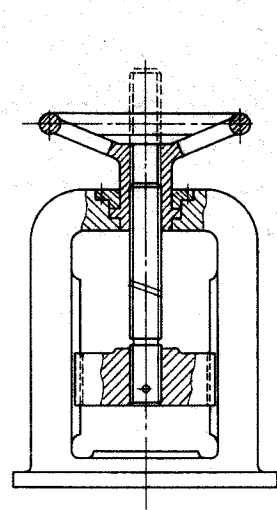
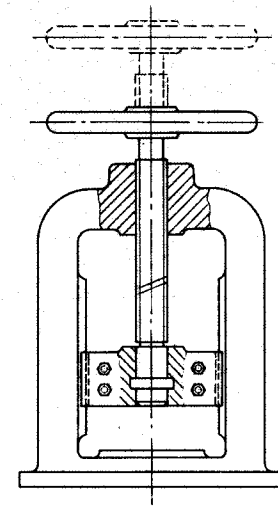
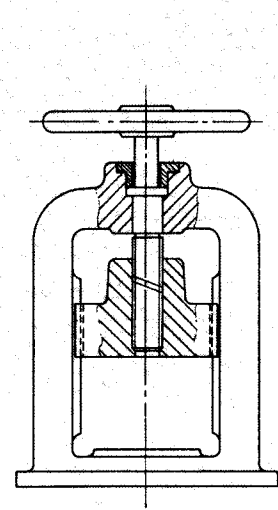
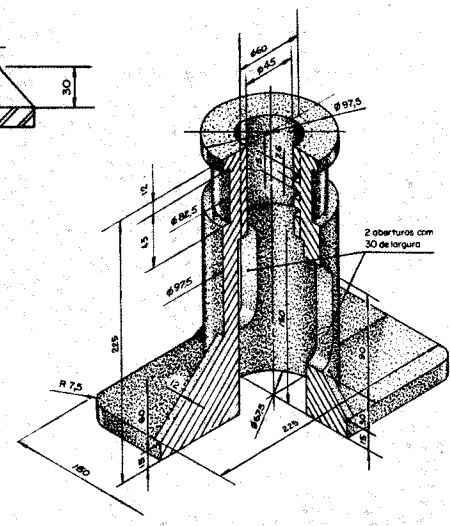
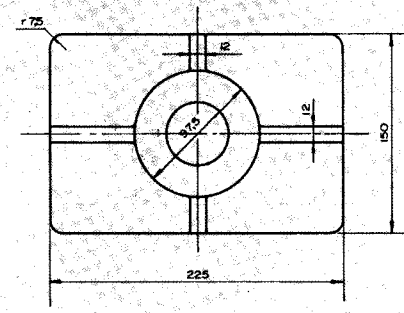
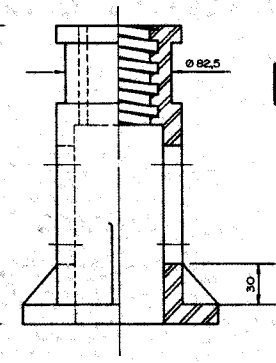
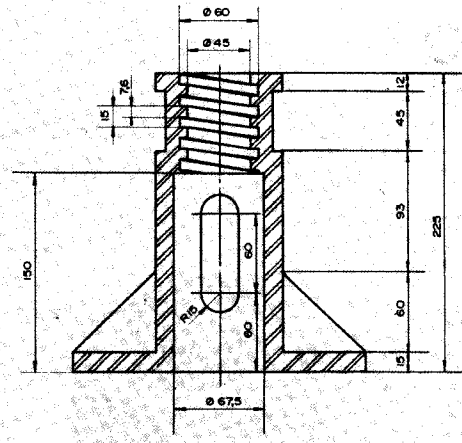
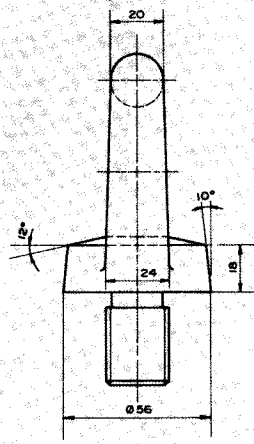
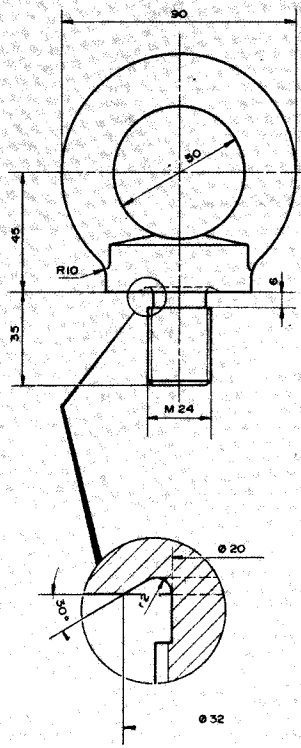

PORCA E PARAFUSO

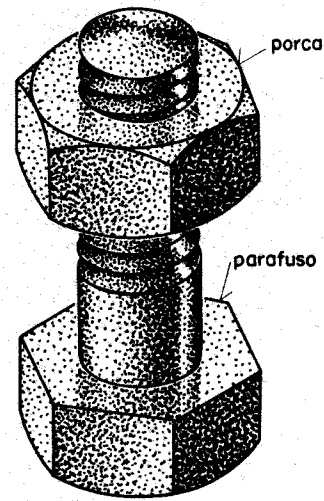
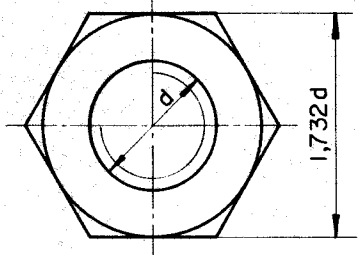
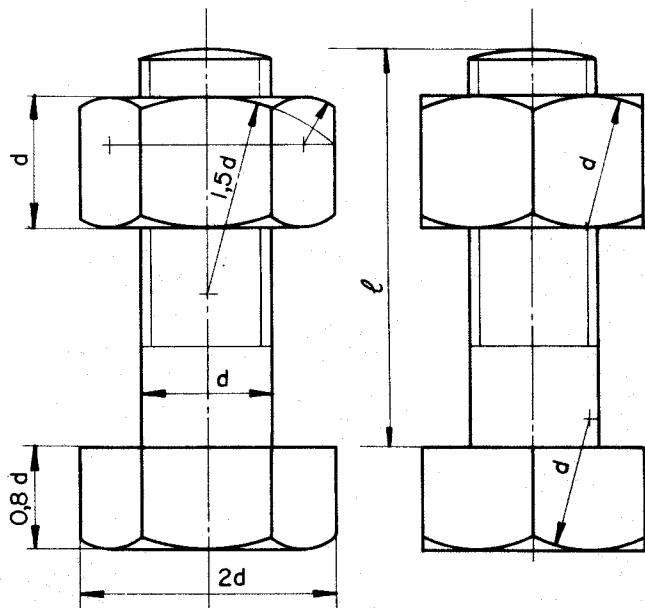

As roscas e os parafusos sextavados são representados com estas proporções.
Para as dimensões reais, consultar as tabelas de "Prontuário do Projetista de Máquinas".

Indicação do parafuso: Parafuso $k \times l$
Ex.: Paraf. M15 x 50

k = tipo da rosca
 d = diâmetro da rosca
 l = comprimento útil

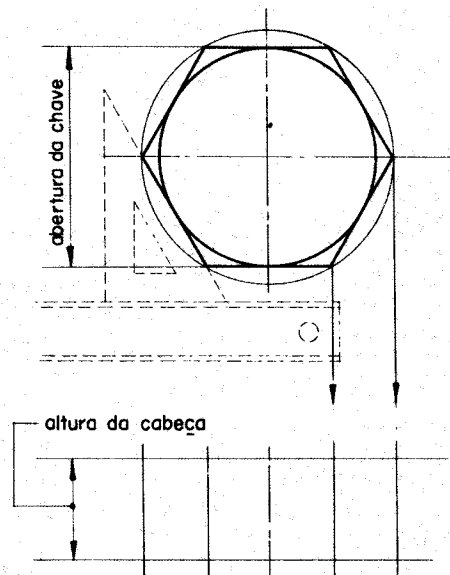

1ª etapa

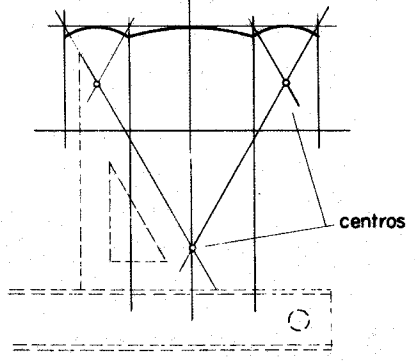

2ª etapa

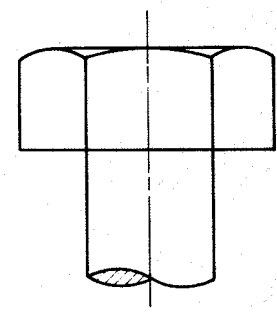

3ª etapa

PROPORÇÕES DOS PARAFUSOS

Indicação : Paraf. z k d x ℓ

z = tipo do parafuso
k = tipo da rosca
d = diametro da rosca
ℓ = comprimento útil

Ex.: Paraf. cabeça chata M10x30.

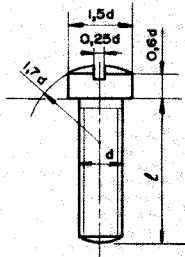

cabeça cilíndrica oval

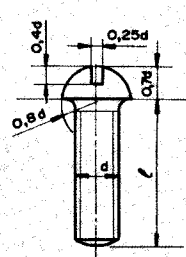

cabeça redonda

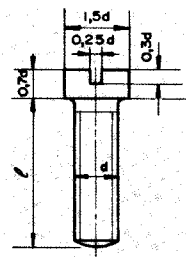

cabeça cilíndrica

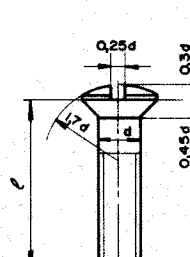

cabeça escareada oval

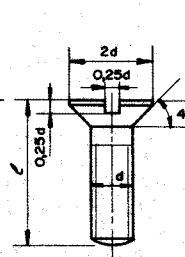

cabeça escareada

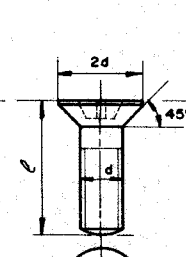

Philip

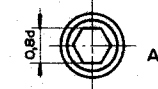
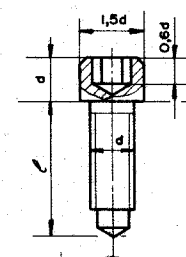

Allen

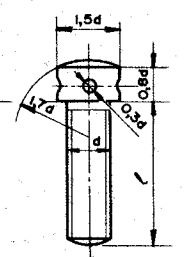

cabeça com pino

PARAFUSOS DE FIXAÇÃO

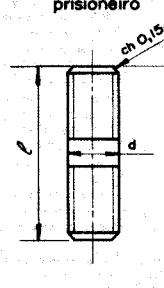
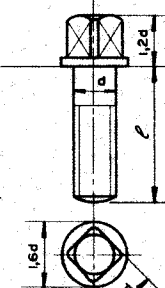
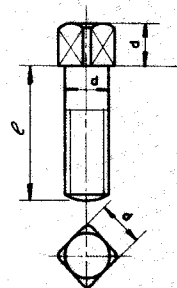
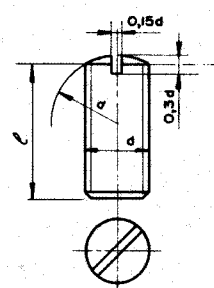
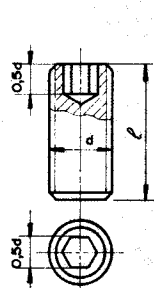

prisioneiro

EXTREMIDADES INTERIORES DOS PARAFUSOS

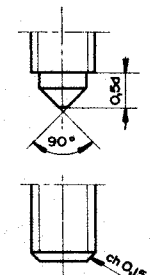
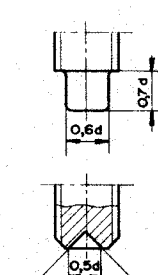
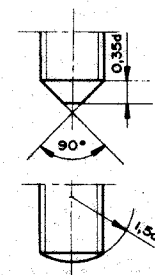

PARAFUSOS PASSANTES PARA MADEIRA

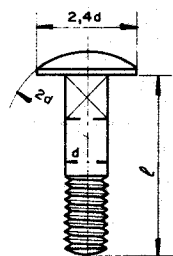

cabeça lenticular

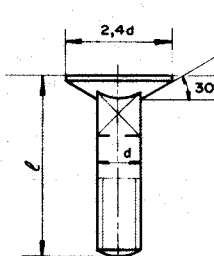

cabeça chata

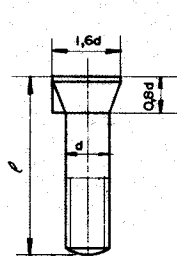

cabeça cônica

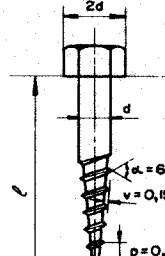

cabeça sextavada

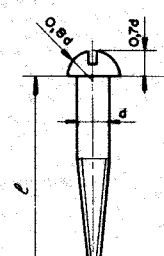

cabeça redonda

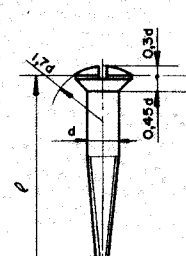

cabeça oval

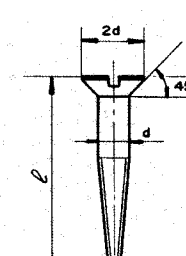

cabeça chata

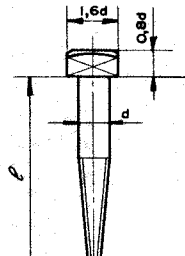

cabeça quadrada

PARAFUSOS PARA MADEIRA COM ROSCA SOBERBA

TIPOS DE PORCAS

Indicação : Porca ykd

Ex. : Porca cega M20

y = tipo da porca
k = tipo da rosca
d = diâmetro da rosca

sextavada

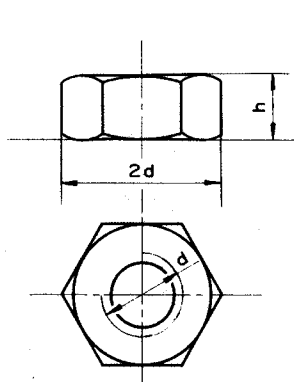

porca pesada : $h = d$
porca normal : $h = 0,8d$
porca leve : $h = (0,4 \div 0,6) d$

com assento cônico

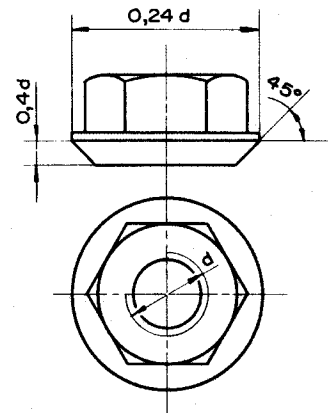

com assento esférico

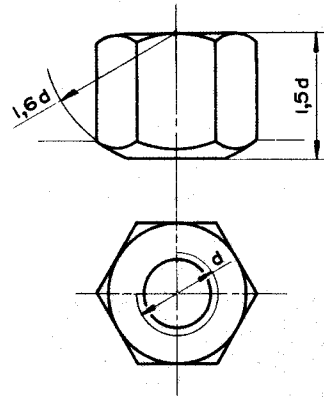

cega

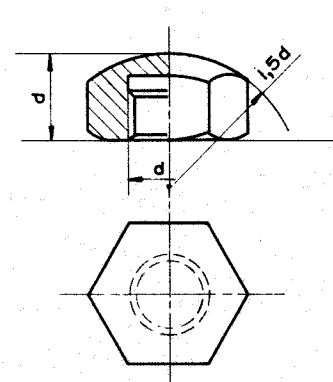

chapéu

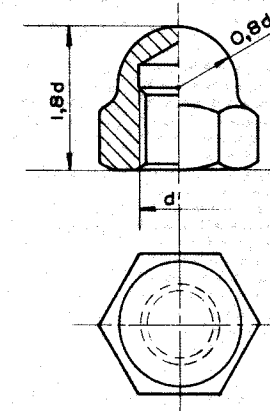

com entalhes radiais

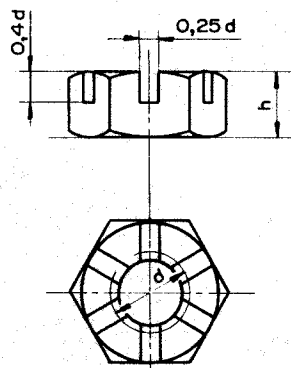

porca pesada : $h = 1,4d$
porca normal : $h = 0,8d$

castelo

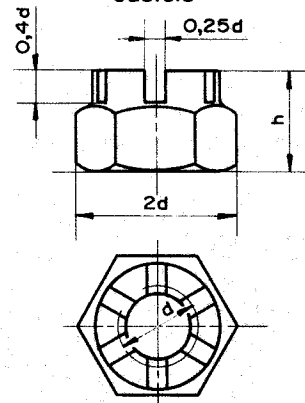

porca pesada : $h = 1,4d$
porca normal : $h = 0,8d$

com furo de fixação

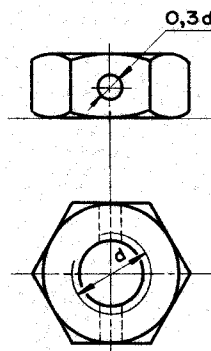

com parafuso de fixação

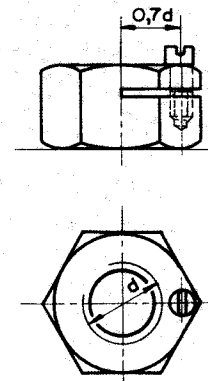

quadrada

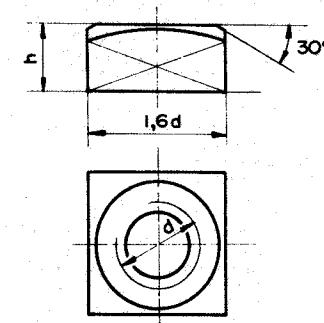

porca alta : $h = 0,8d$
porca baixa : $h = 0,5d$

ARRUELAS E DISPOSITIVOS DE SEGURANÇA

Indicação: arruela d_1

$d_1 \approx 1,1d$

d = diâmetro do parafuso

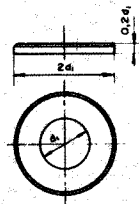

arruela lisa

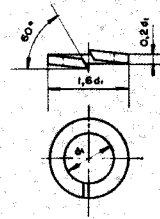

arruela elastica

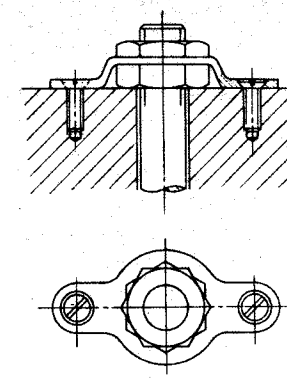
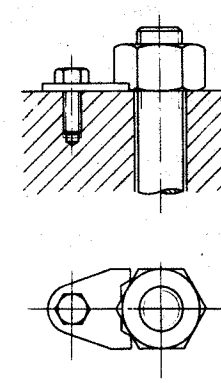
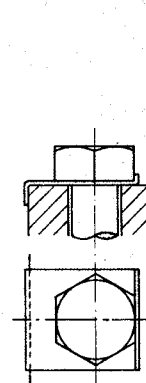
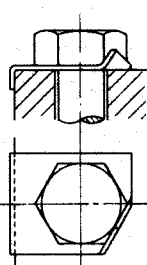
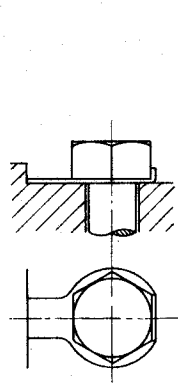
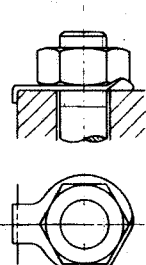
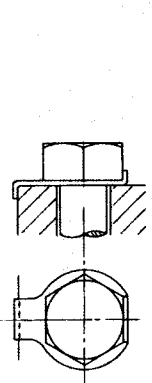
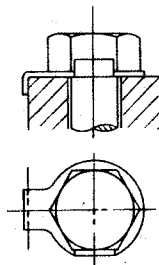
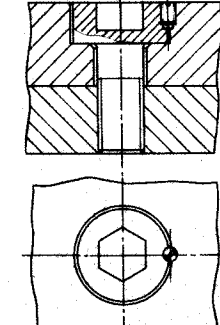
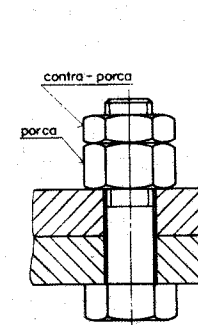
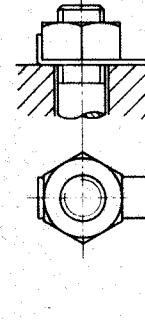
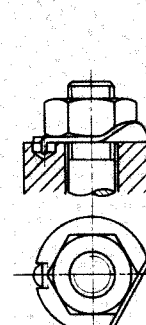
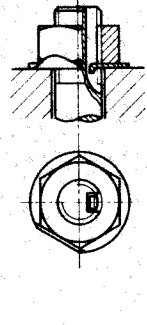
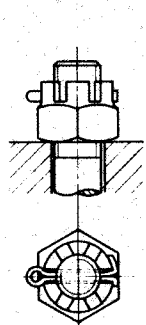
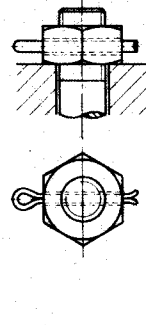
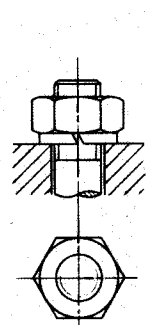
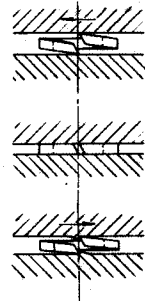
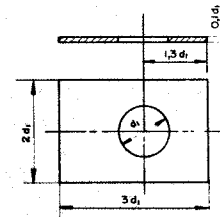
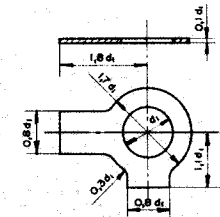
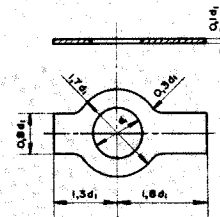
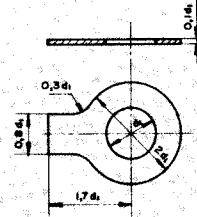
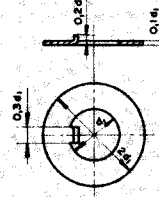
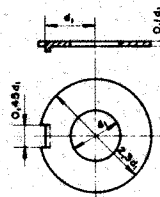

EXEMPLOS DE APLICAÇÃO

PARAFUSO PRISIONEIRO

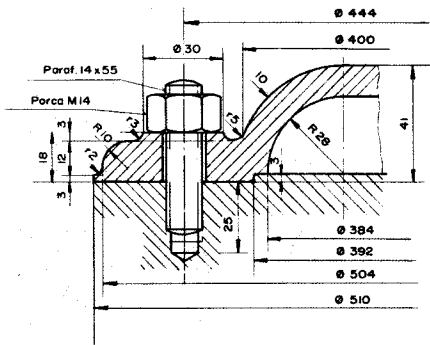

PARAFUSO PASSANTE

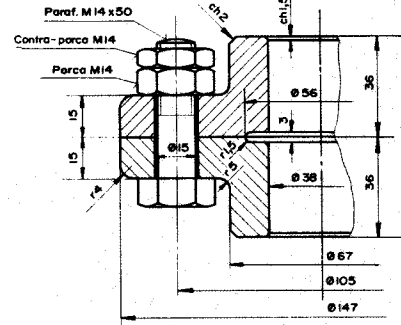

PARAFUSO DE FIXAÇÃO

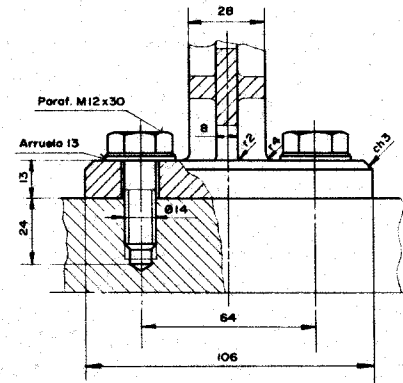

UNIÃO MISTA METAL-MADEIRA

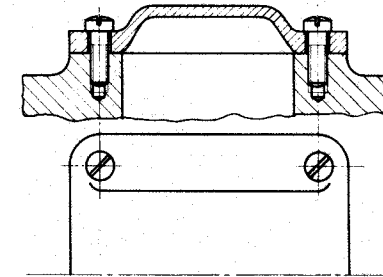
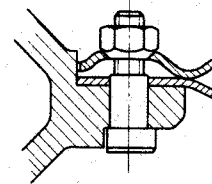
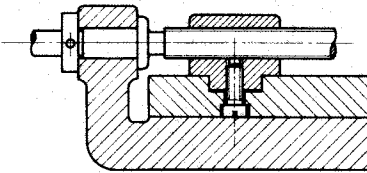
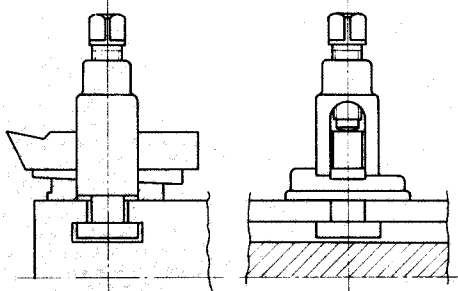
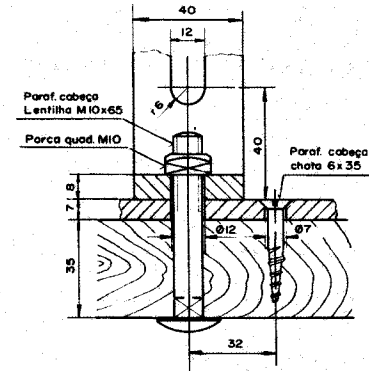

Prever espaço para aperto do parafuso

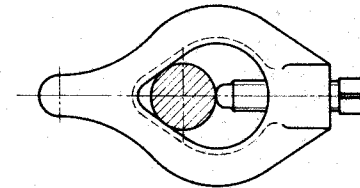
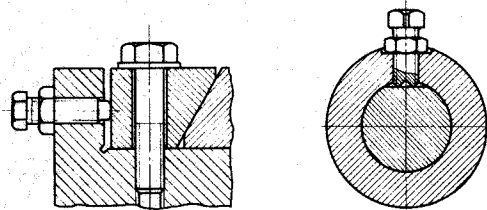
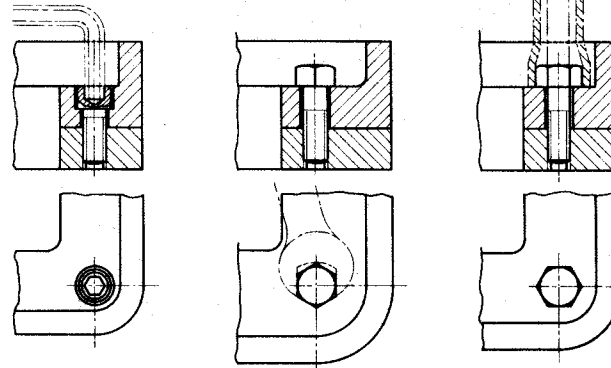

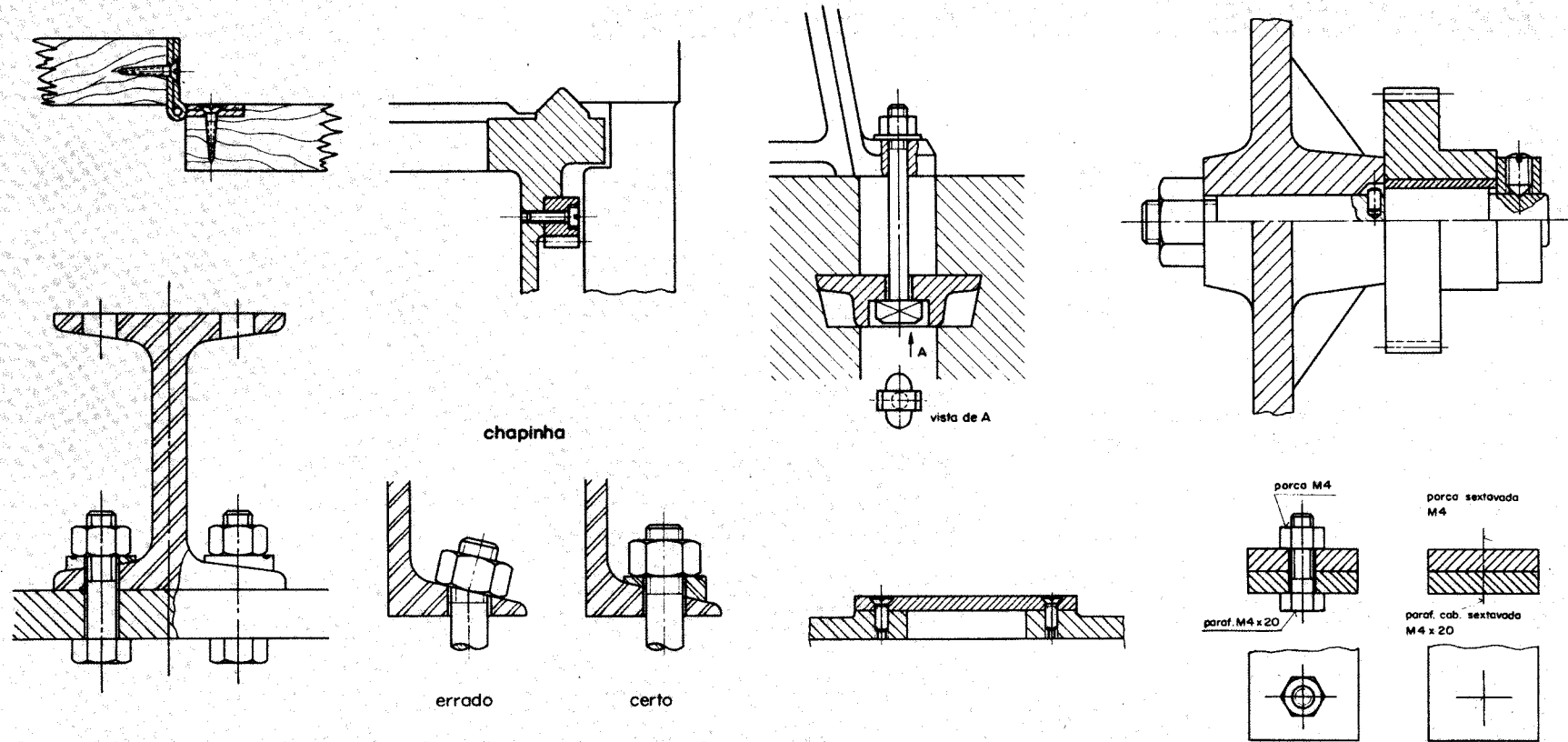

chapinha

errado

certo

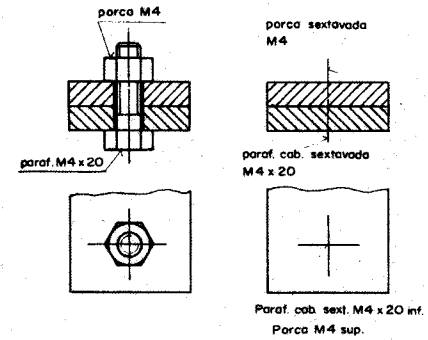

INDICAÇÃO SIMPLIFICADA PARA PEQUENOS DESENHOS: (DIN 30)

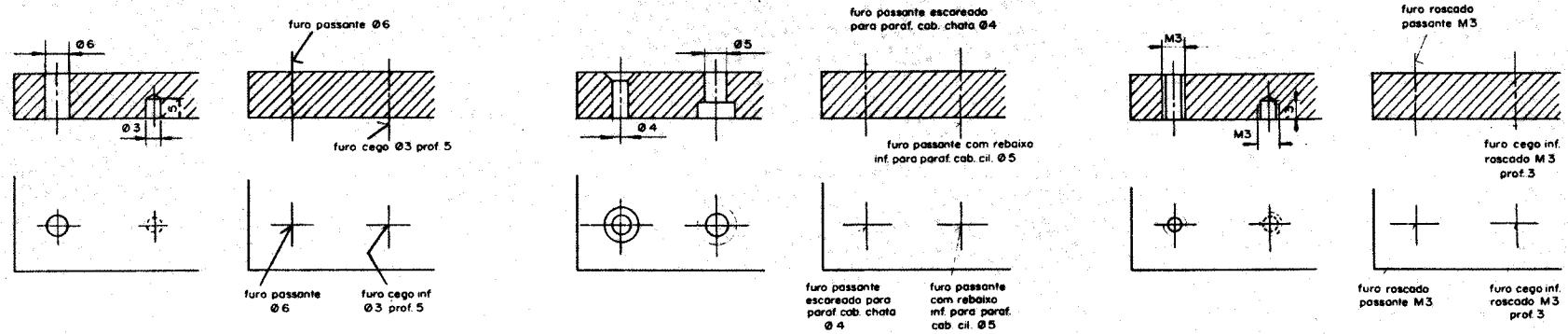

PARAFUSOS E PORCAS ESPECIAIS

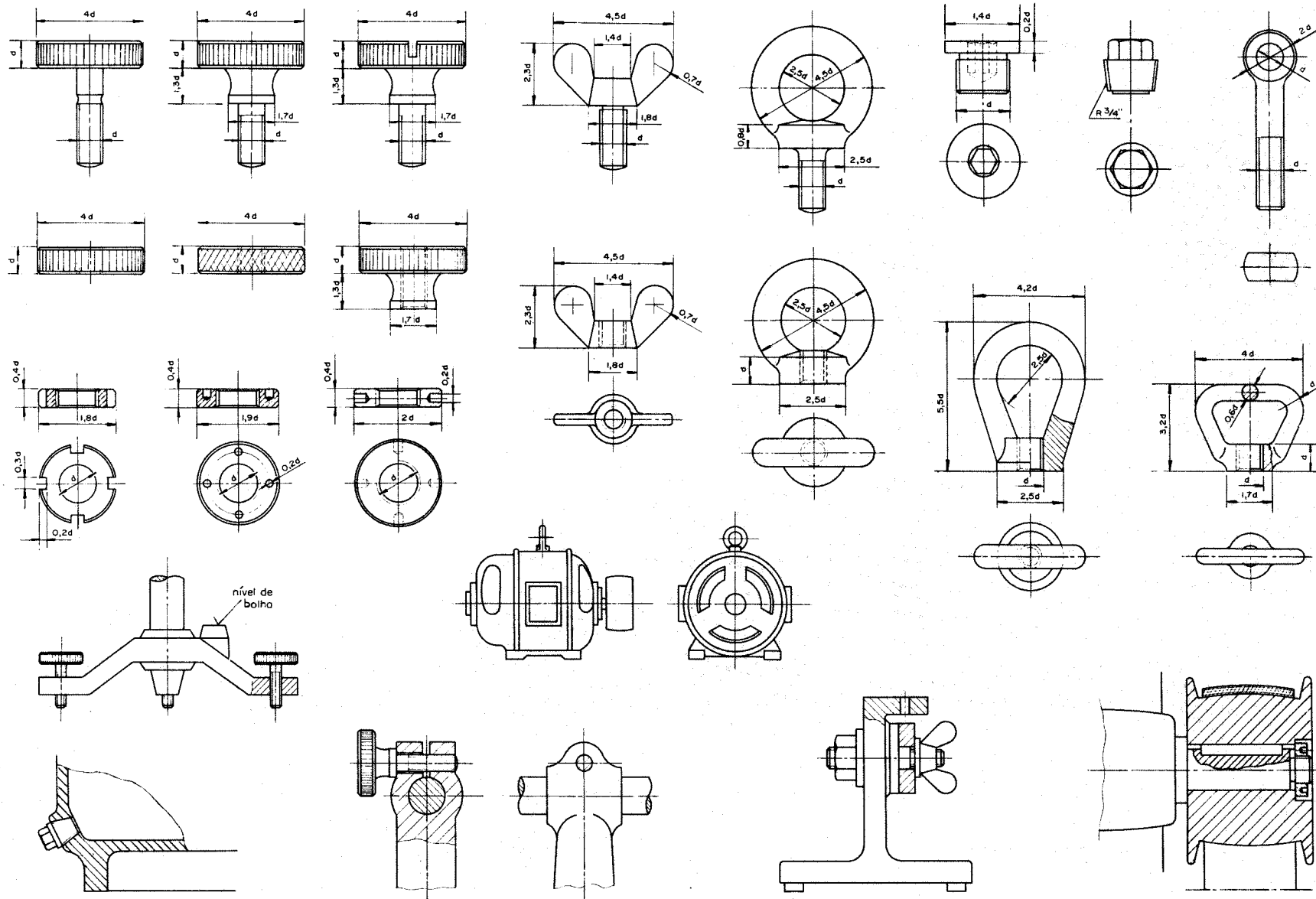

SÍMBOLOS DE PARAFUSOS

Indicação da rêsca		M 8	M 10	M 12	(M 14)	M 16	(M 18)	M 20	M 22	M 24	M 27	M 30	(M 33)	M 36
Diâmetro do parafuso (mm)		8	10	12	14	16	18	20	22	24	27	30	33	36
Secção do núcleo (mm ²)		31,9	50,9	74,3	102	140	171	220	276	317	419	509	636	745
Diâmetro do furo (mm)		8,4	11	13	15	17	19	21	23	25	28	31	34	37
SÍMBOLOS CONVENCIONAIS	Parafuso com furo passante de série normal	8,4			15		19				28	31	34	37
	Parafuso com furo passante fora de série	Indicação de furo e parafuso Ex.: ²⁶ M24												
	Furo roscado	Indicação de furo roscado Ex.: M24												
	Parafuso com cabeça embutida	Cabeça superior embutida Ex.: M20 Cabeça inferior embutida Ex.: M20												
	Parafusar na montagem	8,4			15		19				28	31	34	37
	Furar na montagem	8,4			15		19				28	31	34	37

Até à escala 1:5 os símbolos convencionais serão representados com diâmetros iguais aos furos, para escalas menores usar-se-ão diâmetros iguais as cabeças dos parafusos.

Evitar os valores entre parênteses.

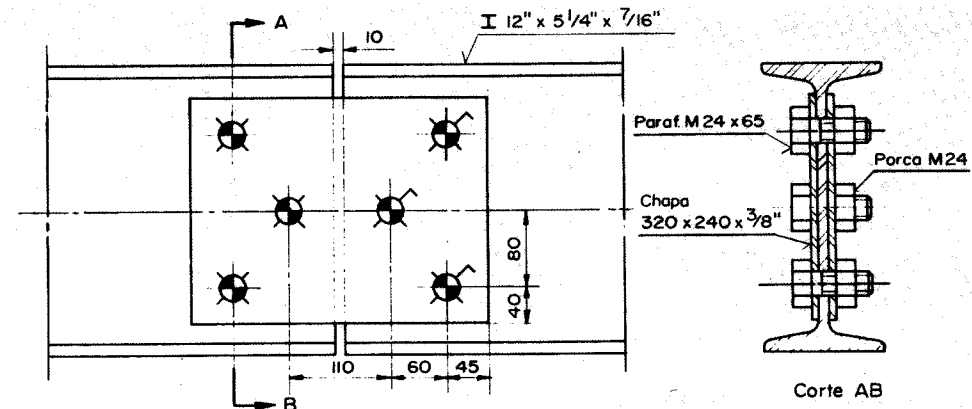

INDICAÇÃO DO ACABAMENTO E TRABALHO SUPERFICIAL

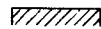

Superfícies em bruto.

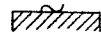

Superfícies em bruto, porém, limpas de rebarbas e saliências.



Superfícies apenas desbastadas

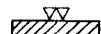

Superfícies alisadas



Superfícies polidas

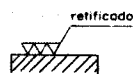

Para qualquer outro acabamento, indicar ao lado o modo de obtê-lo.

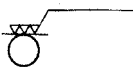

Superfícies sujeitas a tratamento especial, são indicadas sobre uma linha horizontal.

Ex.: temperado, niquelado, pintado, etc.

Estes sinais são indicados sobre as linhas de contorno da superfície em consideração, ou na impossibilidade, sobre as linhas de chamada que saem desta.

O recartilhado é indicado da seguinte maneira:

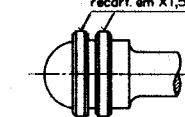
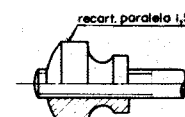
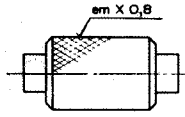
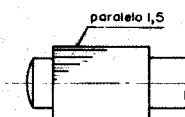
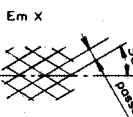
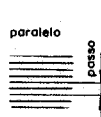

Passos aconselhados - Paralelo: 0,5 - 0,8 - 1 - 1,5 mm
Em X: 0,5 - 0,8 - 1 - 1,5 - 2 mm

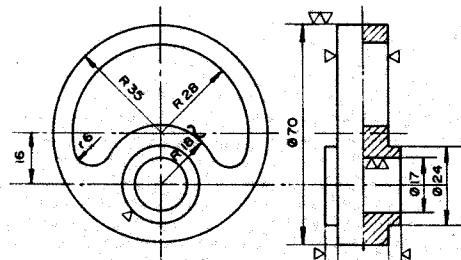

Cada superfície é indicada com o sinal de trabalho relativo.

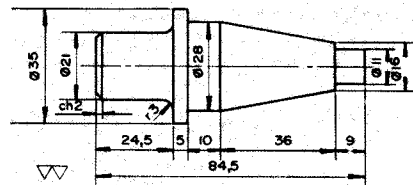

Quando todas as superfícies deverão receber o mesmo acabamento, o sinal de trabalho é indicado em baixo à esquerda do desenho ou em lugar visível.

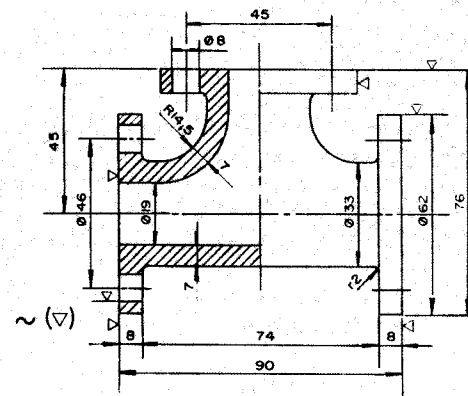

Esta peça deverá ter todas as superfícies em bruto, sem rebarbas, exceto as indicadas com ∇ as quais serão desbastadas.

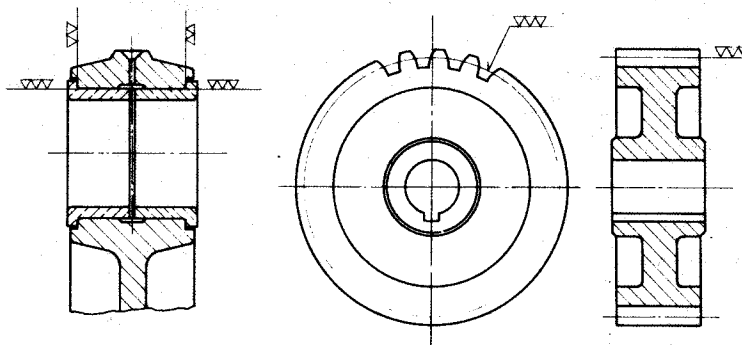

Neste exemplo: As faces em contato receberão, ambas, os mesmos acabamentos.

O acabamento dos dentes das engrenagens é indicado no diâmetro primitivo.

Se um determinado acabamento só se referir a uma parte da superfície, esta será indicada por uma linha de cota (com ou sem medida).

CONICIDADE E INCLINAÇÃO

CONICIDADE é a relação $(D-d) : \ell$

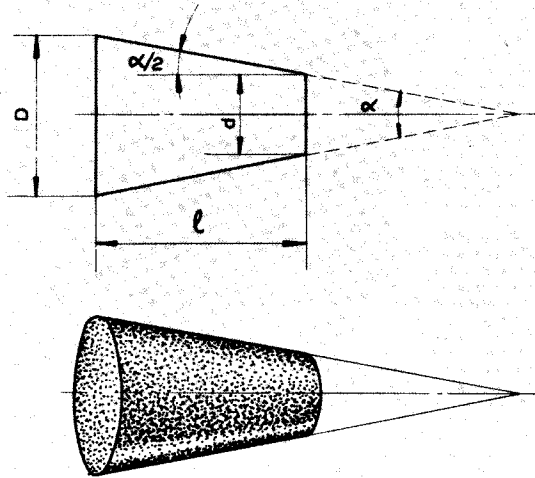

CONICIDADES PADRONIZADAS

a) Cone Morse

Nº	Conicidade 1:k
0	1 : 19,212
1	1 : 20,047
2	1 : 20,020
3	1 : 19,922
4	1 : 19,254
5	1 : 19,002
6	1 : 19,180

INCLINAÇÃO é a relação $(H-h) : \ell$

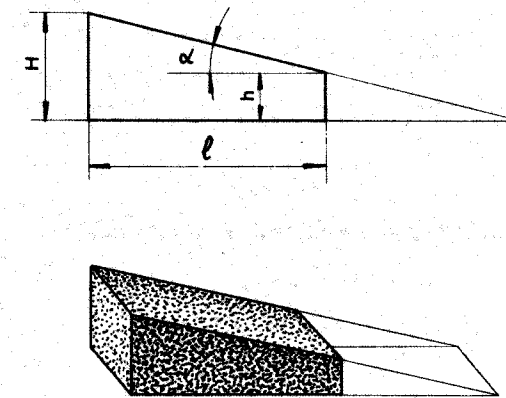

A conicidade é indicada paralelamente ao eixo, e seu valor pode ser calculado das seguintes maneiras:

b) Cone métrico: Conicidade 1:20 = 5%

A inclinação é indicada paralelamente a face inclinada e seu valor pode ser calculado das seguintes maneiras.

$$k = \frac{\ell}{D-d} = \frac{100}{p\%} = \frac{1}{2} \cotg \frac{\alpha}{2}$$

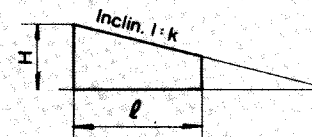
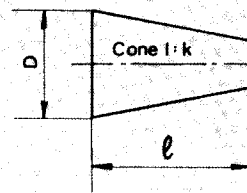

$$k = \frac{\ell}{H-h} = \frac{100}{p\%} = \cotg \alpha$$

$$p\% = 100 \frac{D-d}{\ell} = \frac{100}{K} = 200 \operatorname{tg} \frac{\alpha}{2}$$

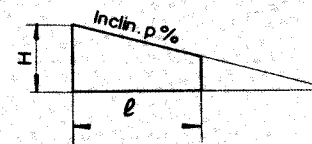
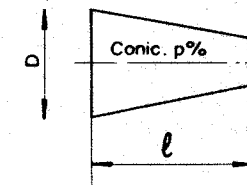

$$p\% = 100 \frac{H-h}{\ell} = \frac{100}{K} = 100 \operatorname{tg} \alpha$$

$$\alpha/2 = \operatorname{arc} \operatorname{tg} \left(\frac{D-d}{2} : \ell \right) = \operatorname{arc} \operatorname{tg} \frac{p\%}{200} = \operatorname{arc} \cotg 2K$$

$$\alpha = \operatorname{arc} \operatorname{tg} \left(\frac{H-h}{\ell} \right) = \operatorname{arc} \operatorname{tg} \frac{p\%}{100} = \operatorname{arc} \cotg K$$

CONTRA-PINO FIXO

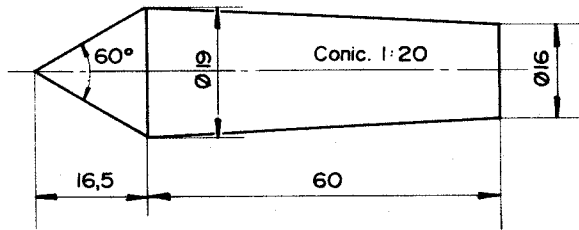

ENGRAXADEIRA LUB

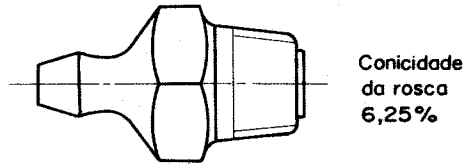

CAPA DO MANDRIL

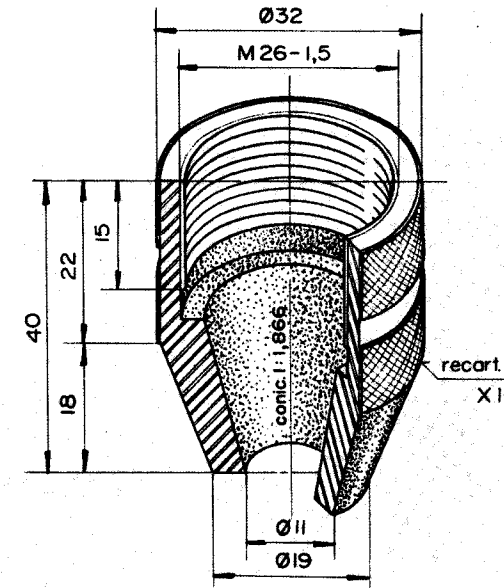

CONICIDADES INTERNA E EXTERNA

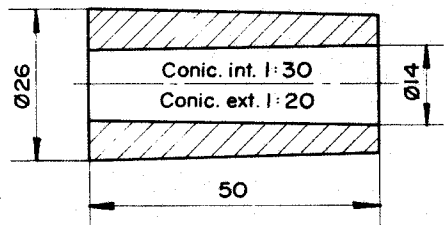

ESPIGA

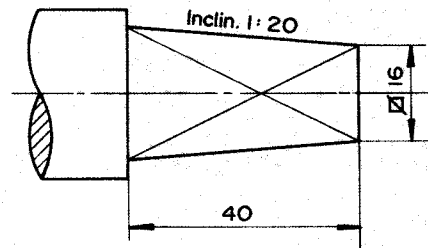

PERFIL DE VIGAS

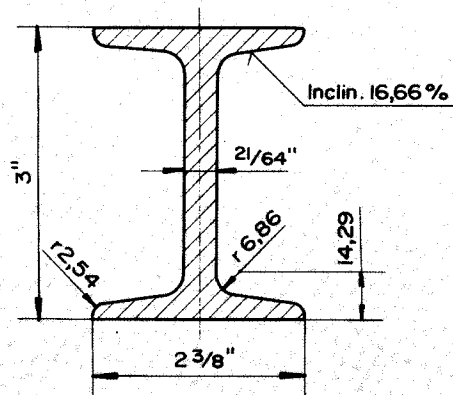

CHAVETA ENCAIXADA

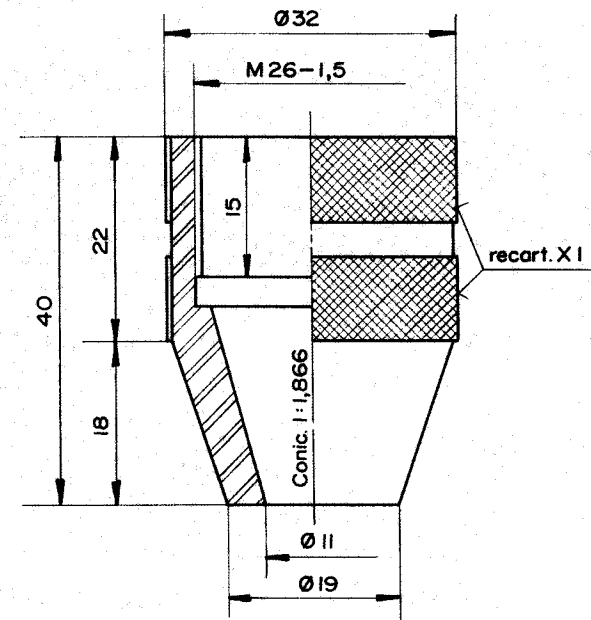
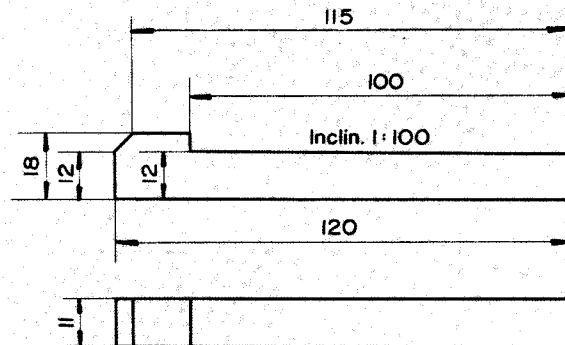

PINOS E CONTRA-PINOS

PINOS CILÍNDRICOS

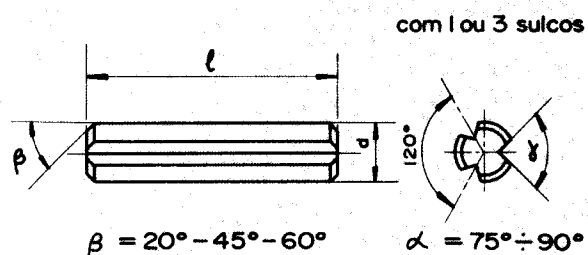

Comprimentos l normais: 8-9-10-12... 22-25-28-30-35... 150-160... 320

Indicação de um pino $d \times l \times l_1$ Exemplos: Pino cil. sem cabeça 65x95x70
Pino cil. com cabeça 10x35x31,5

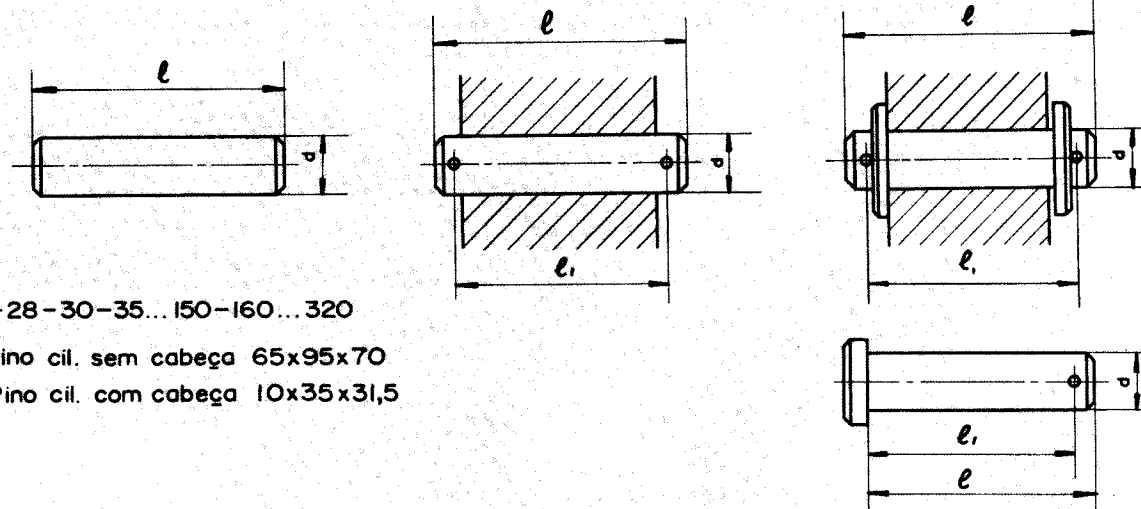

PINOS CÔNICOS

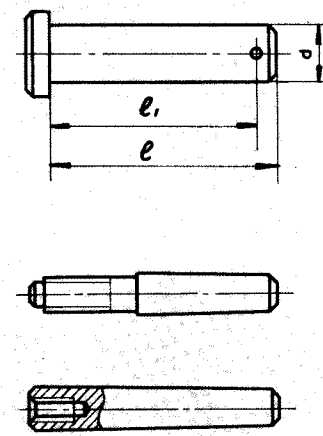
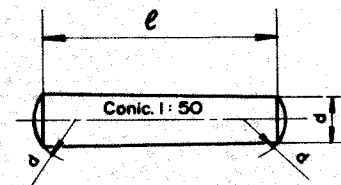
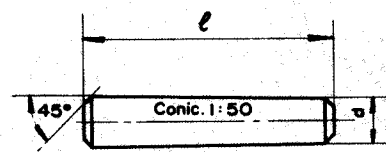
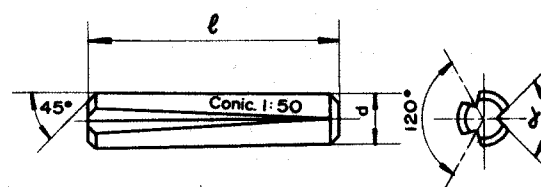

O diâmetro indicativo do pino cônico é o menor.

Comprimentos l normais: 4-6... 32-36-40-45... 150-165-180-200-230-260

Indicação de um pino cônico: Pino cônico $d \times l$ Ex.: Pino cônico 4x35

CONTRA-PINO

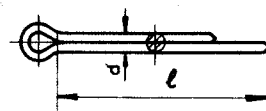

Material: aço

Material: outro metal

Indicação de um contra-pino

Contra-pino $d \times l$

d = diâmetro do furo

PINO ELÁSTICO

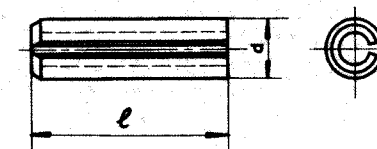

Indicação: Pino elástico $d \times l$

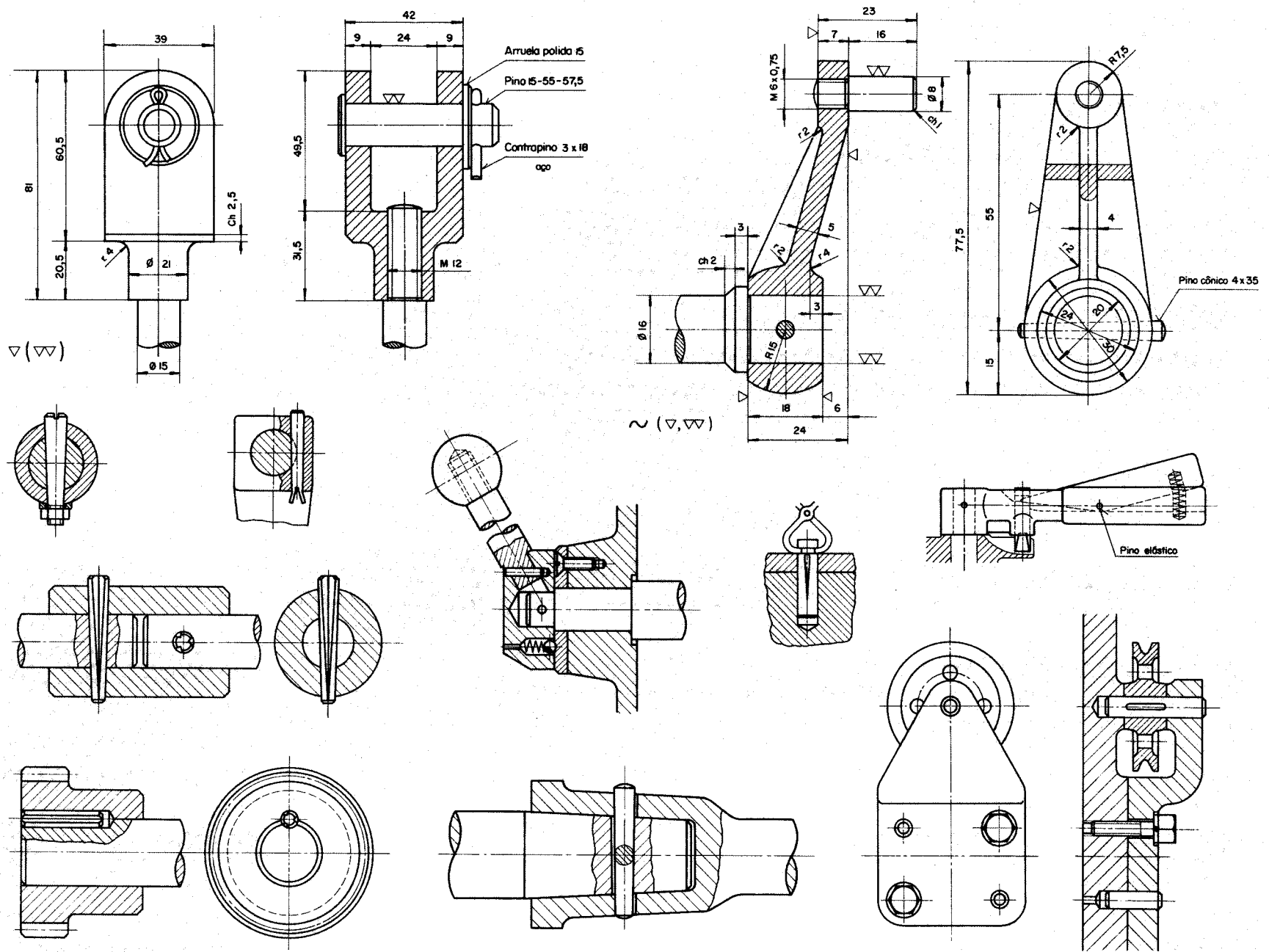

CHAVETAS E LINGUETAS

Chaveta (união forçada) Lingueta ou chaveta deslizante

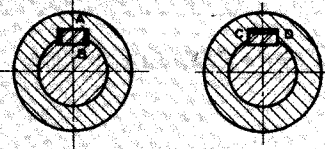

trabalham as faces A e B (inclin.) trabalham as faces C e D (paralelas)

→ direção do golpe para montar
- - - direção do golpe para desmontar

Dimensões dos rasgos

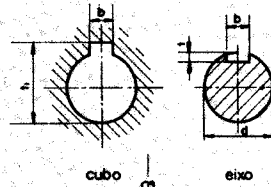

hubo eixo

FRESAGEM DOS RASGOS DE CHAVETAS

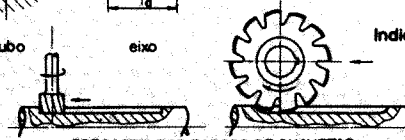

Obs.: As chavetas não se representam cortadas em sentido longitudinal.

Indicações: chaveta encaixada com cabeça $b \times h \times l$

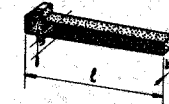

chaveta encaixada fixa $b \times h \times l$



UNIÕES COM CHAVETAS

$l > 1,5d$

Chaveta encaixada móvel

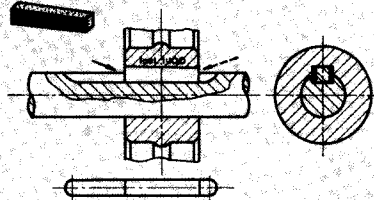

Chaveta encaixada fixa

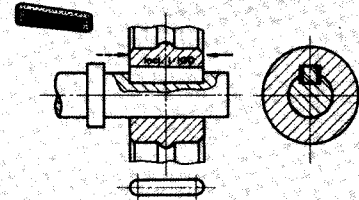

Chaveta plana

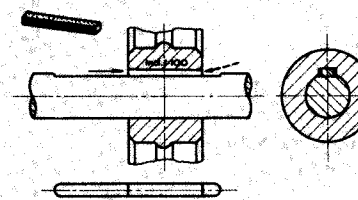

Chaveta côncava

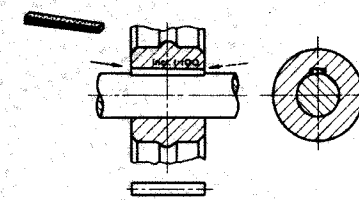

Chaveta encaixada com cabeça

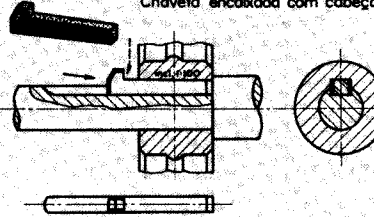

Chaveta plana com cabeça

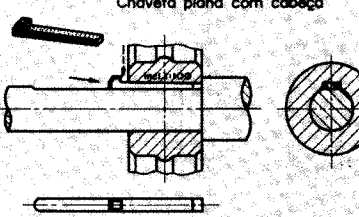

Chaveta côncava com cabeça

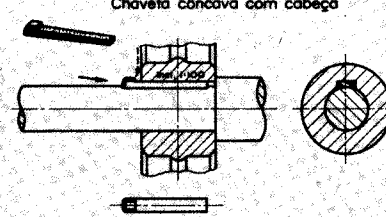

Chavetas tangenciais

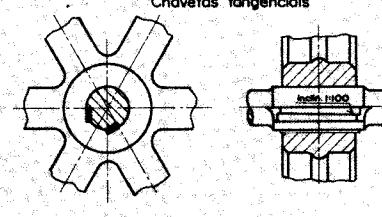

UNIÕES COM LINGUETAS

Lingueta de ajuste fixo (extremidades retas)

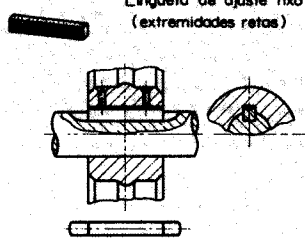

Lingueta de ajuste fixo (extremidades arredondadas)

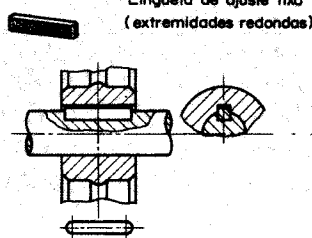

Chaveta deslizante (extremidades arredondada)

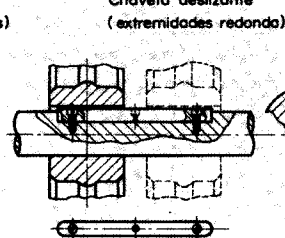

Chaveta deslizante (extremidades retas)

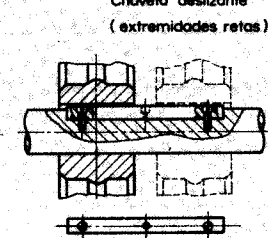

UNIÃO COM CHAVETA MEIA LUA

Chaveta meia-lua, americana ou WOODRUFF

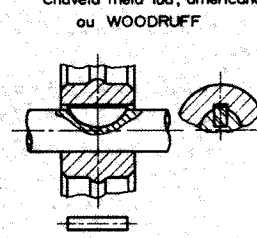

UNIÕES FORÇADAS - EFEITO DE CUNHA

MANIVELA DE EXTREMIDADE

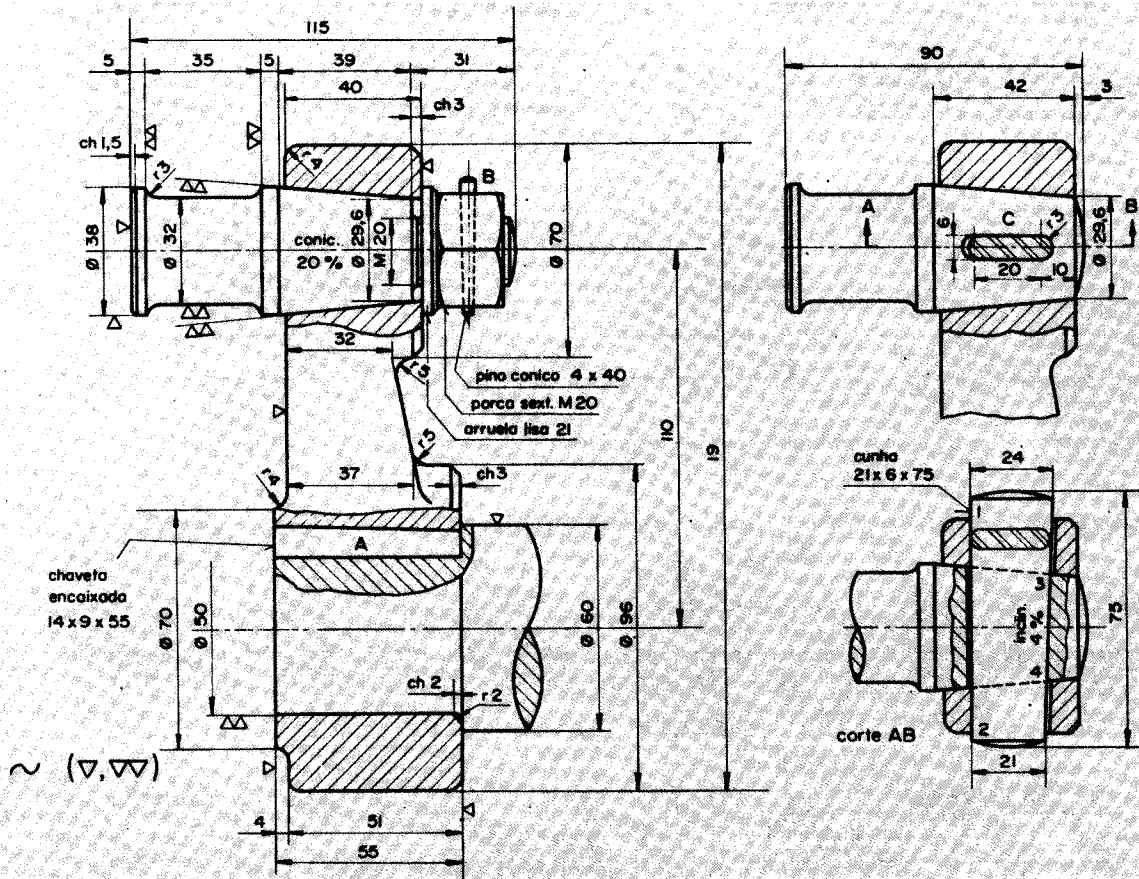

A união do eixo com a manivela é obtida por meio da chaveta encaixada (A). O pino da manivela é forçado no seu lugar por meio da porca (B) na qual é colocado um pino cônico de segurança.

POLIA PARA CORREIA PLANA

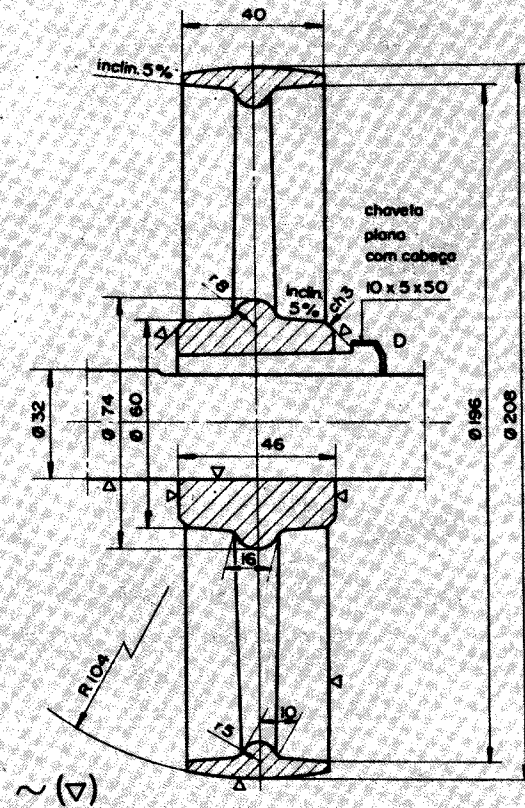

A união é obtida por meio da chaveta plana com cabeça (D). Observar que não há encaixe no eixo e sim um simples aploamento.

O mesmo pino pode ficar em união forçada com a manivela por meio da cunha C. Observar que a cunha força contra a parede 1-2 do furo da manivela e contra a parede oposta 3-4 do furo do pino.

MANIVELA DE COMANDO

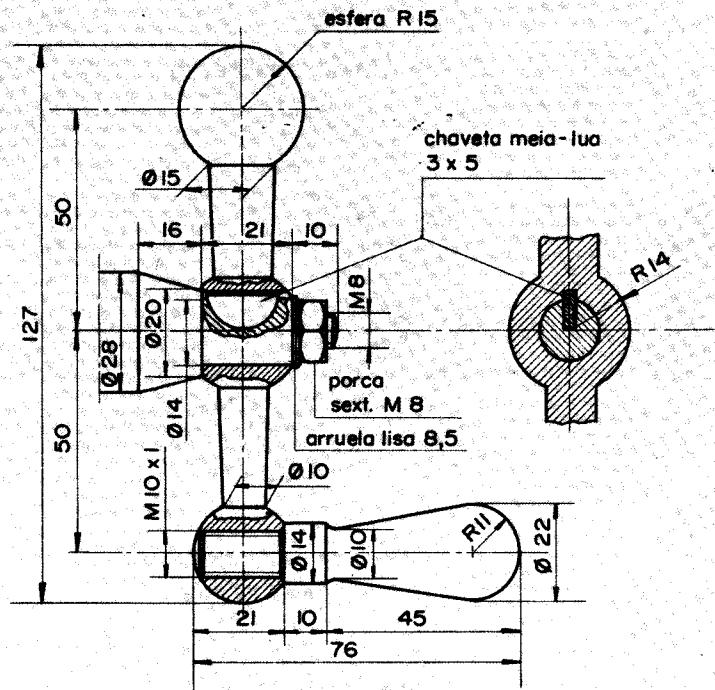

FRICÇÃO CÔNICA

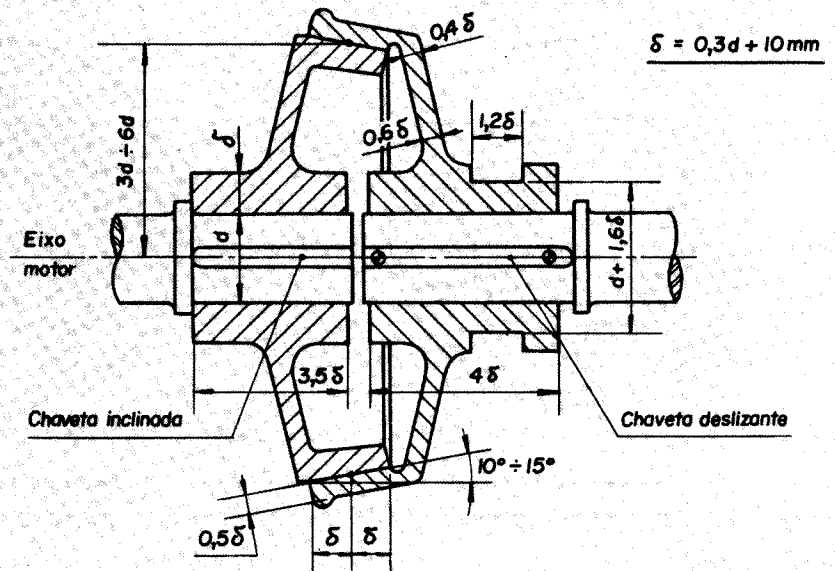

CÂMBIO

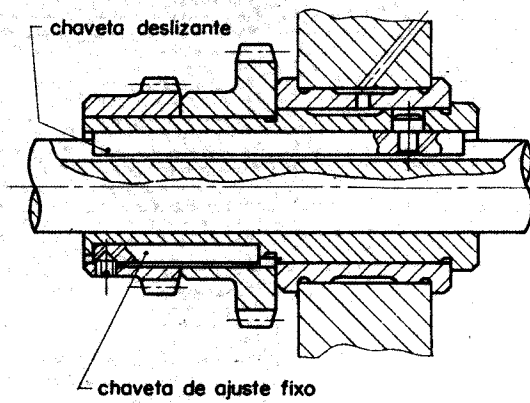

ENGATE

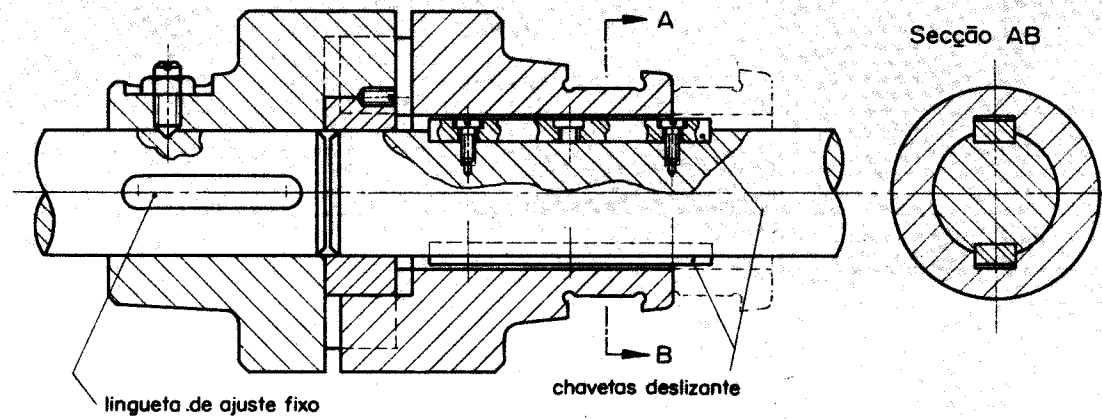

EIXOS RANHURADOS

União forçada

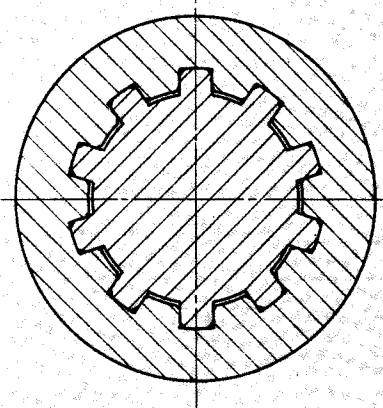

Pressão sobre o fundo das ranhuras do cubo

União forçada

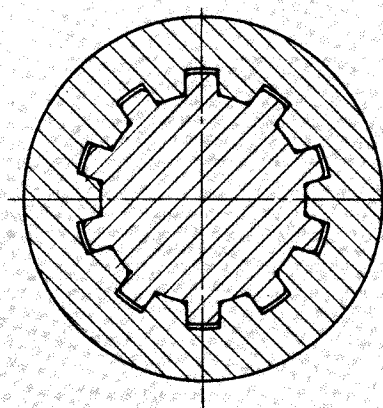

Pressão sobre o fundo das ranhuras do eixo

União deslizante

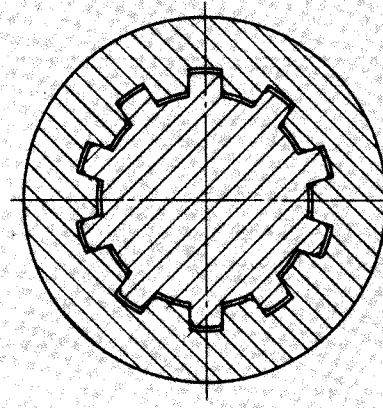

Pressão sobre as laterais das ranhuras

EIXO CARDAN

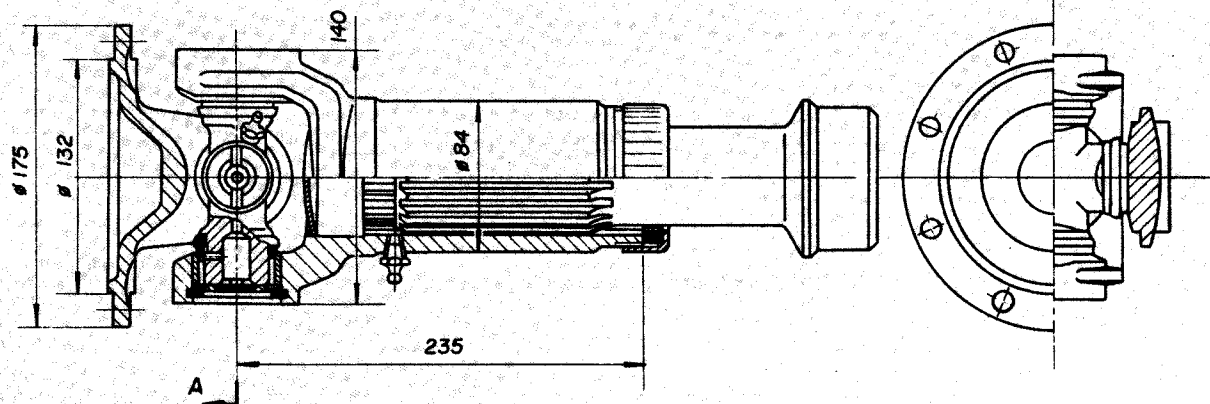

FRICÇÃO DE DISCO

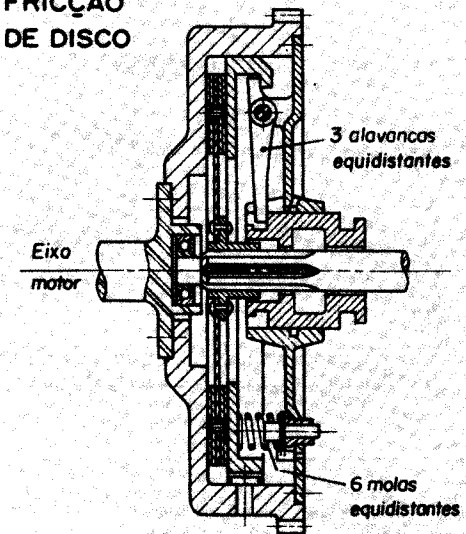

Obs.: não se cortam rebites em sentido longitudinal.

REBITES

Norma ABNT EB-48/R

de cabeça redonda larga		de cabeça redonda estreita	de cabeça tronco-cônica		de cabeça vazada	
sem borda	com borda		sem colarinho	com colarinho	sem calota	com calota
Recipientes submetidos à pressão		Estruturas metálicas	Construções navais		Quando não é possível o uso dos tipos normais	
$D = (1,7 \div 1,80) d$ $h = (0,7 \div 0,75) d$ $R = (1,0 \div 0,90) d$		$D = 1,60 d$ $h = 0,65 d$ $R = 0,82 d$		<p>PROPORCIONAMENTO</p> $D = 1,6 d$ $h = 0,7 d$ $c = 1,1 d$ $b = 0,5 d$		$\alpha = 75^\circ$ para $d = 10 \div 16$ mm $\alpha = 60^\circ$ para $d = 19 \div 25$ mm $\alpha = 45^\circ$ para $d = 28 \div 43$ mm $h = 0,5 d$ $R \approx 2 d$

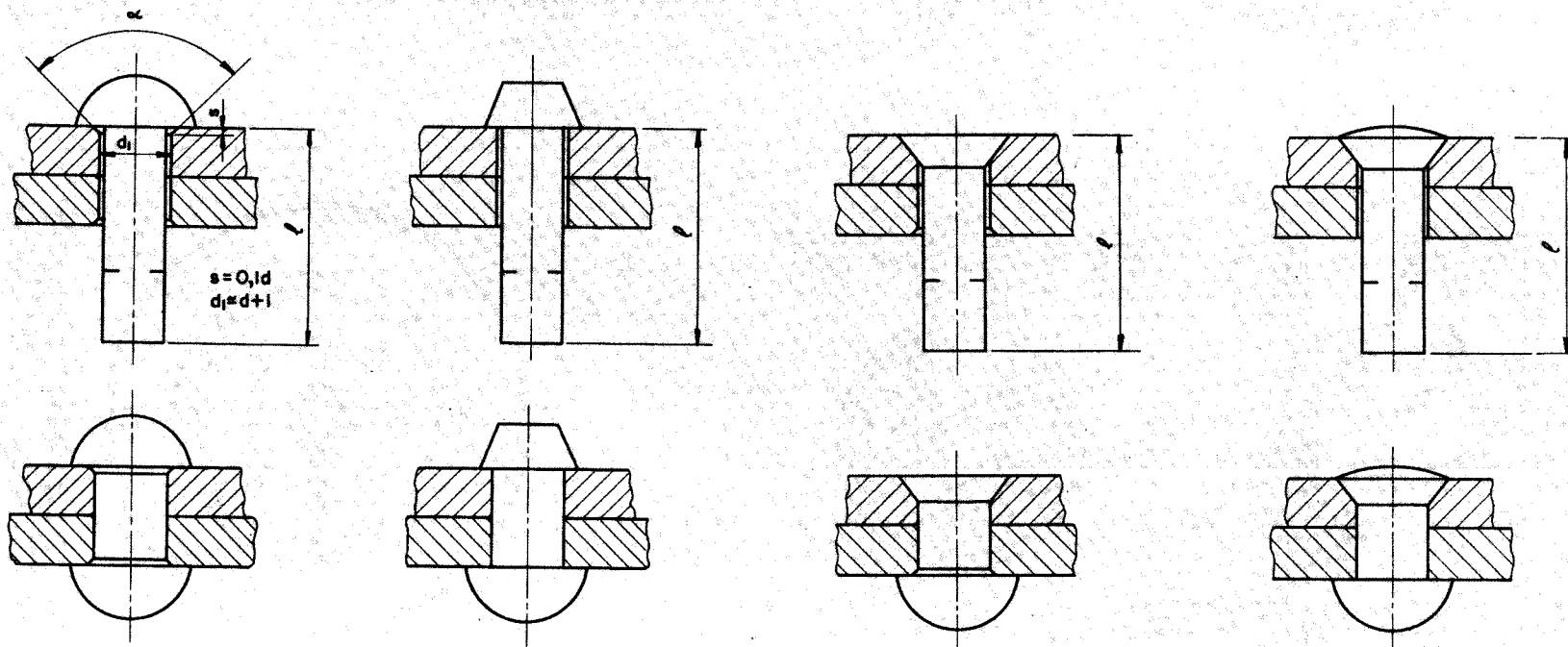

APLICAÇÃO DE REBITES

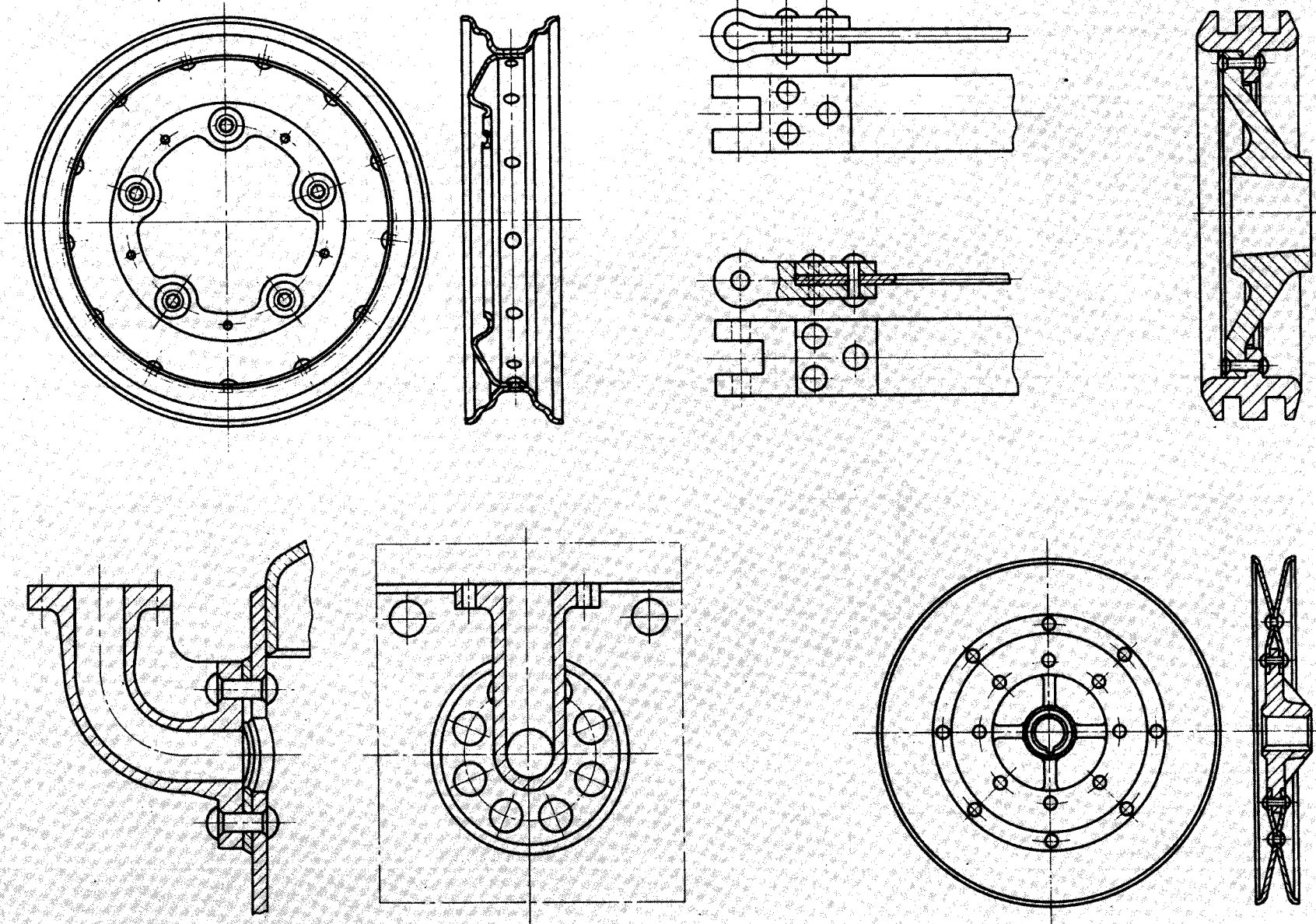

REBITES ESPECIAIS

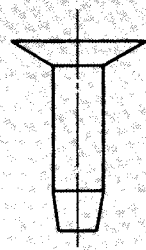

rebite para
correia



rebite macho e fêmea

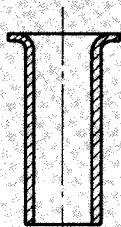

rebite
furado



rebites sem cabeça

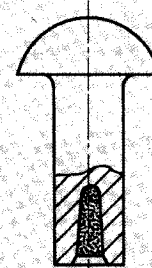

rebite com
carga explosiva

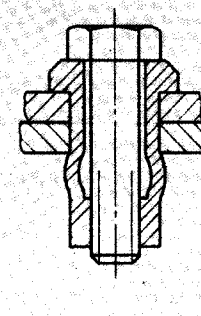
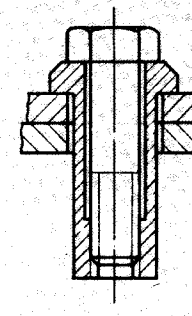
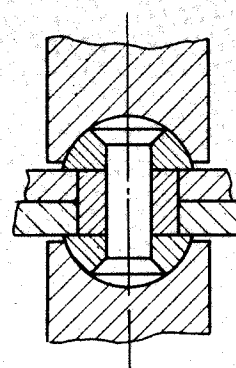
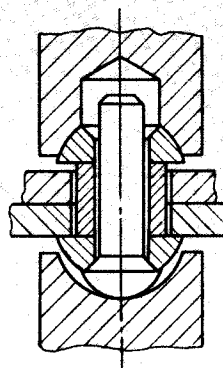
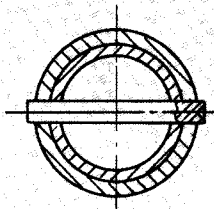
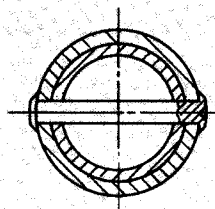
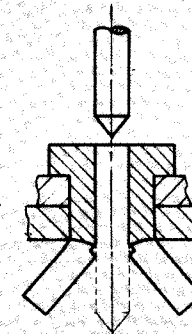
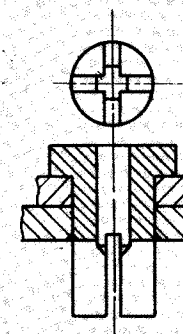
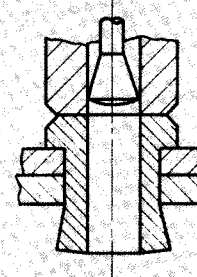
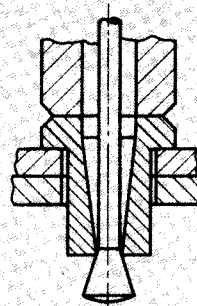
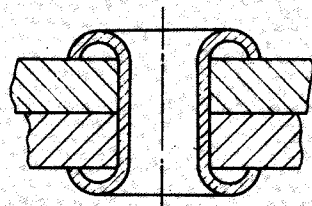
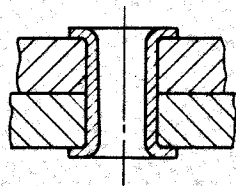
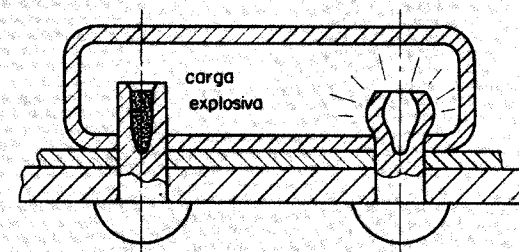

REBITAGEM DE CALDEIRARIA

POR SOBREPOSIÇÃO

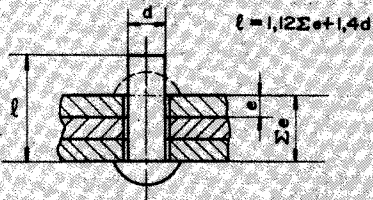
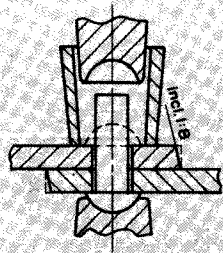

Indicação: rebite dx l

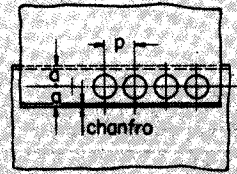

Simple (1 fileira de rebites)

$$d = 7\sqrt{e} - 4$$

$$p = 2d + 8$$

$$a = 1,5d$$

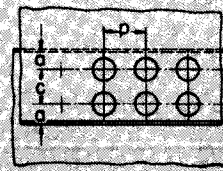

Dupla (2 fileiras de rebites)
c/ rebites em paralelo

$$d = 7\sqrt{e} - 4$$

$$p = 2,6d + 10$$

$$a = 1,5d$$

$$c = 0,8p$$

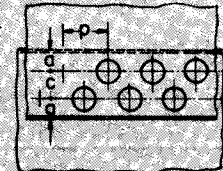

Dupla (2 fileiras de rebites)
c/ rebites à Ziq-zag.

$$d = 7\sqrt{e} - 4$$

$$p = 2,6d + 15$$

$$a = 1,5d$$

$$c = 0,6p$$

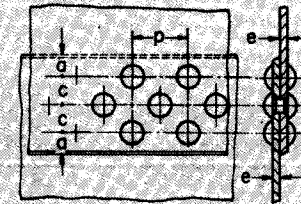

Tripla (3 fileiras de rebites)

$$d = 7\sqrt{e} - 4$$

$$p = 3d + 22$$

$$a = 1,5d$$

$$c = 0,5p$$



COM SIMPLES COBREJUNTA



SIMPLES

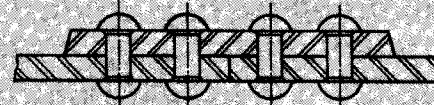

DUPLA

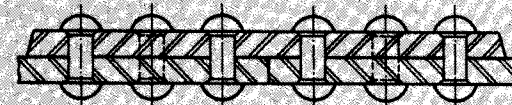

TRIPLA

COM DUPLA COBREJUNTA

ESPECIAIS 3 CHAPAS

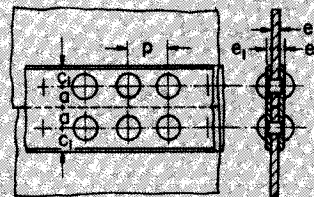
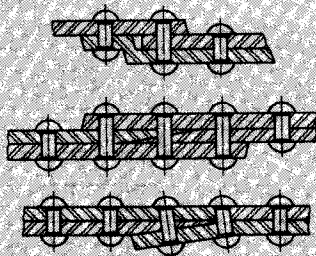

Simple

$$d = 7\sqrt{e} - 5$$

$$p = 2,6d + 10$$

$$a = 1,5d$$

$$c_1 = 1,35d = 0,9a$$

$$e_1 = (0,6 \div 0,7)e$$

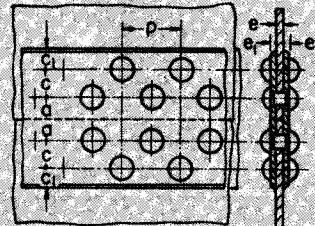

Dupla

$$d = 7\sqrt{e} - 6$$

$$p = 3,5d + 15$$

$$a = 1,5d$$

$$c = 0,5p$$

$$c_1 = 1,35d = 0,9a$$

$$e_1 = (0,6 \div 0,7)e$$

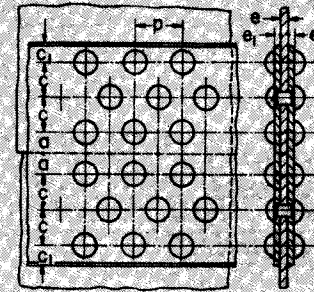

Tripla

$$d = 7\sqrt{e} - 7$$

$$p = 3d + 10$$

$$a = 1,5d$$

$$c = 0,75p$$

$$c_1 = 1,35d = 0,9a$$

$$e_1 = (0,6 \div 0,7)e$$

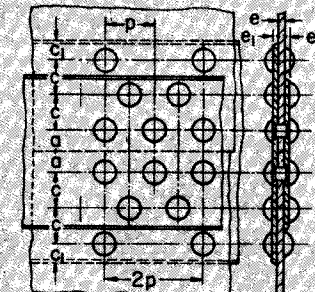

Tripla incompleta

$$d = 7\sqrt{e} - 8$$

$$p = 3d + 7$$

$$a = 1,5d$$

$$c = 0,66p$$

$$c_1 = 1,35d = 0,9a$$

$$e_1 = (0,6 \div 0,7)e$$

ESTRUTURAS REBITADAS

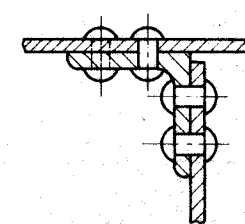
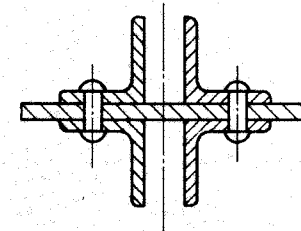
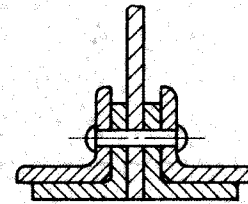
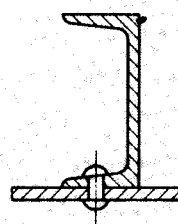
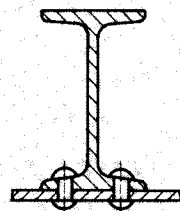
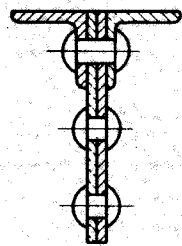
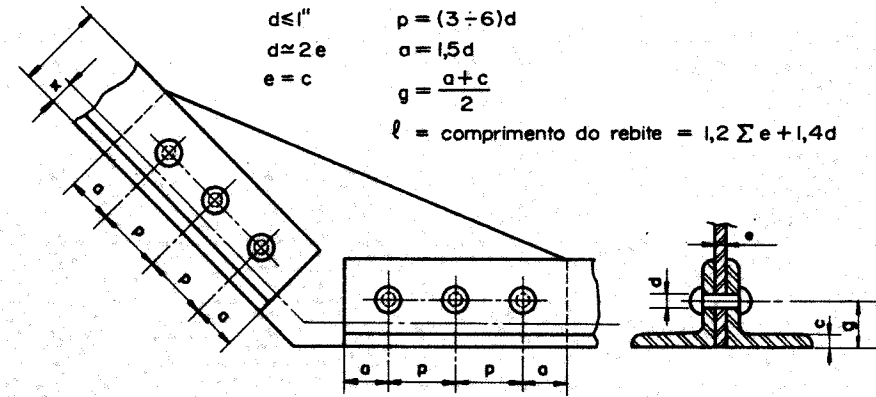
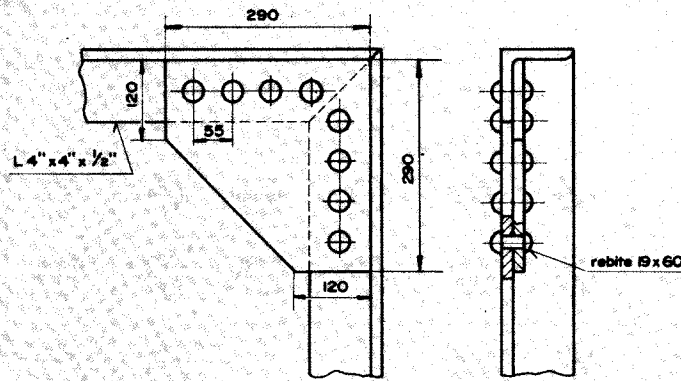

As linhas baricêntricas das cantoneiras devem convergir para um mesmo ponto.

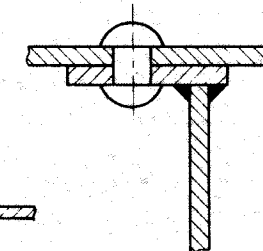
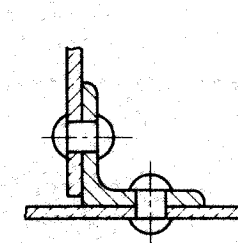
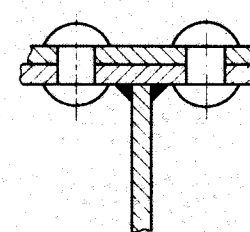
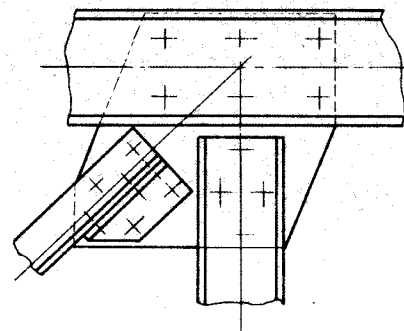
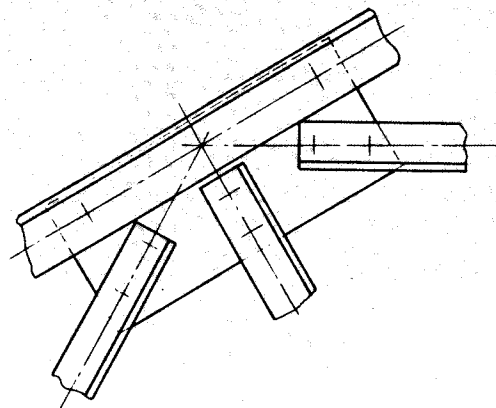

SÍMBOLOS DE REBITES

Diâmetro do rebite (mm)		(8)	10	12	(14)	16	(18)	20	22	24	27	30	(33)	36	
Diâmetro do furo (mm)		8,4	11	13	15	17	19	21	23	25	28	31	34	37	
SÍMBOLOS CONVENCIONAIS	Cabeças redondas de ambos os lados														
	Cabeças chatas	Cabeça superior embutida													
		Cabeça inferior embutida													
		Ambas as cabeças embutidas													
	Rebitar na montagem														
	Furar na montagem														

Até à escala 1 : 5 os símbolos convencionais serão representados com diâmetros iguais aos furos, para escalas menores usar-se-ão diâmetros iguais as cabeças dos rebites.

Evitar os valores entre parênteses.

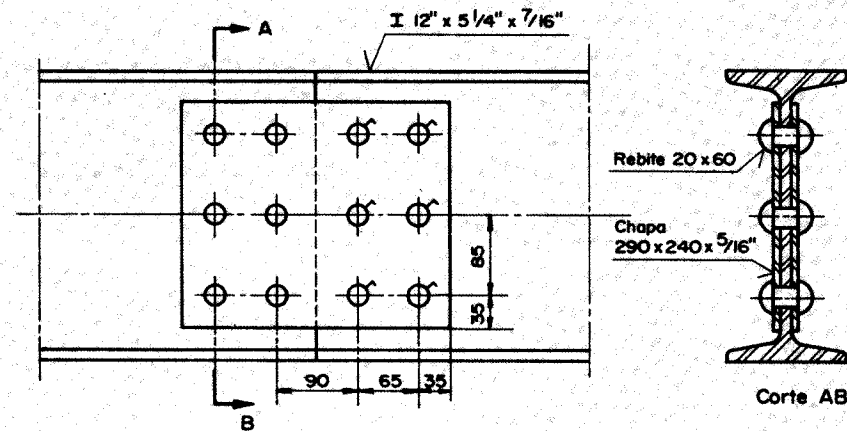
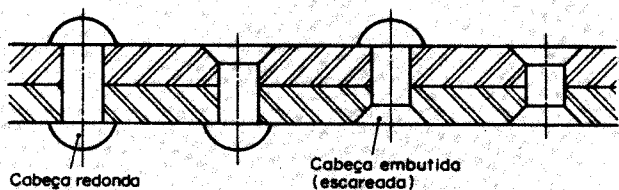

SÍMBOLOS DE SOLDAS - DIN 1911 - 1912

SOLDA POR PRESSÃO (POR RESISTÊNCIA ELÉTRICA)			
Tipo da solda		Representação simbólica	
De topo			
Com fusão			
Por pontos em série			
Por pontos em cadeia			
Por pontos escalonados			
Sobreposta			
De topo			

SOLDA POR FUSÃO (A ARCO OU A GÁS)				
Tipo da solda		Representação		Represent. simbólica
De borda (I)				
Solda de topo (I)	Em I			
	Em V			
	Em X			
Solda em ângulo	Cordão reforçado e contínuo			
	Cordão plano contínuo			
	Cordão aliviado contínuo			

Além da grossura do cordão (7 mm) pode-se indicar também o comprimento da solda (200 mm)

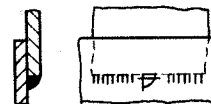
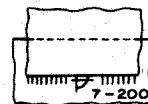

Solda oculta

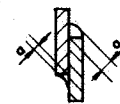

Significado de a

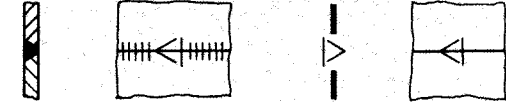

(I) As soldas planas são indicadas com traço reto em vez de arco.

Tipo		Representação (I)		Representação simbólica	
Junta frontal	Cordão angular de um lado				
	Cordão angular de um lado				
Juntas superpostas	Cordão contínuo	Cordão angular de um lado			
		Cordão angular nos dois lados			
	Cordão descontinúo	Cordão angular de um lado			
		Cordão angular nos dois lados			
	Cordões cont. nus e descont.	Cordão angular nos dois lados			
Junta com sobrejunta cordão cont.	Cordão angular contínuo nos dois lados				
	Cordão interrompido reforçado				
Junta em T	Cordão interrompido aliviado				
	Cordões reforçados alternados				
	Cordões cont. nus e descont.	Cordão angular nos dois lados			

Tipo		Representação (I)		Representação simbólica	
Juntas com ranhura	Furo alongado				
	Furo redondo				
Juntas em T	Cordão contínuo	Cordão angular em um lado			
		Cordão angular nos dois lados			
	Cordão descontinúo	Cordão angular em um lado			
		Cordão angular nos dois lados			
	Cordões cont. nus e descont.	Cordão angular alternado			
Junta em angulo cordão contínuo	Cordão angular nos dois lados				
	Cordão angular externo				
	Cordão angular externo e interno				

(I) Os cordões reforçados, planos e aliviados são representados com os símbolos correspondentes.

SOLDA A ARCO ELÉTRICO OU A GÁS

NORMA AMERICANA

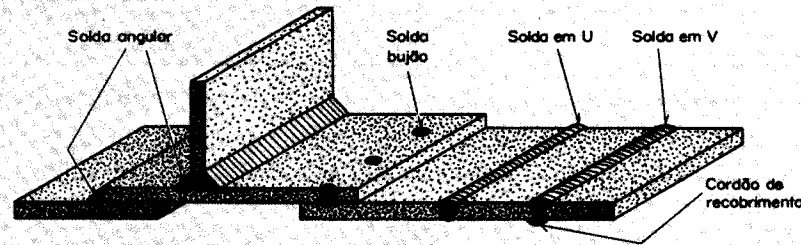

INDICAÇÃO E SÍMBOLOS

Recortes de chapas					bujão e ranhura	Cordões	
reto	V	bisel	U	J		recobrimento	filète ou angular
	V	∇	U	J			

Acabamento do cordão		Solda em todo o contorno	Solda de campo ou de montagem
raso	convexo		

Soldar varando a junta	Revestimento ou enchimento

JUNTAS

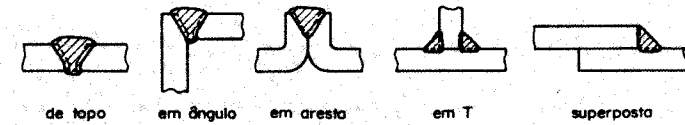

ENTALHES DUPLOS

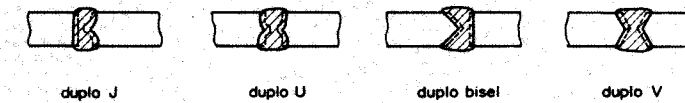

LADO OPOSTO E LADO SETA

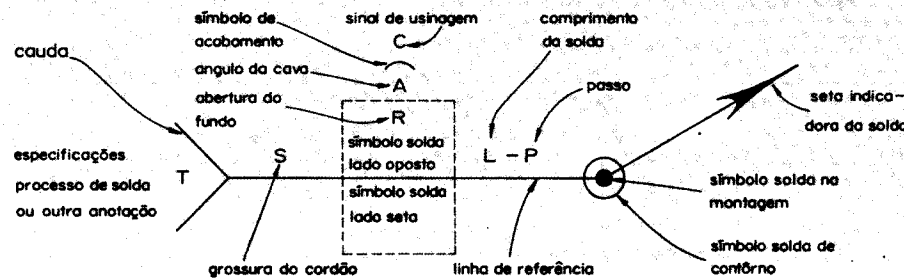
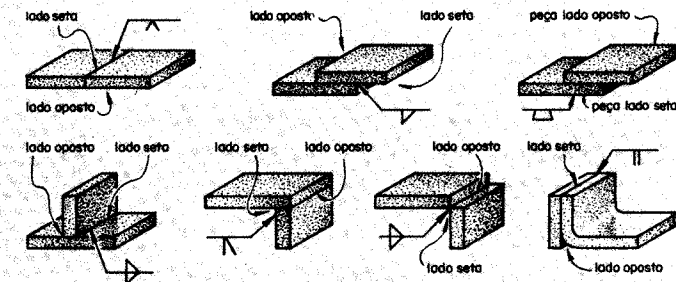

EXEMPLO

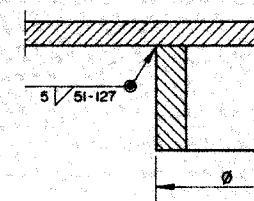

Significado

- Cordão de solda do lado seta.
- Grossura do cordão: 5 mm
- Cordão de solda angular
- Solda descontínua em todo contorno
- Comprimento dos trechos de solda: 51 mm
- Passo: 127 mm
- Solda na montagem

NORMAS - ESPECIFICAÇÕES DOS CORDÕES DE SOLDA

1 - Aplicar as setas tantas vezes quantas forem as mudanças bruscas na direção do cordão, exceto quando o cordão for o mesmo para todo o contorno, caso em que será empregado o símbolo correspondente.

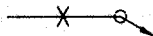

2 - Todos os cordões são considerados contínuos, exceto quando indicado em contrário.

3 - As dimensões colocadas nos símbolos são indicadas sempre em mm.

4 - Usar a cauda da seta para especificar particularidades da soldagem se houver, caso contrário omiti-la.

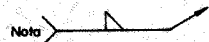

5 - Nas soldas do lado seta, representar o símbolo no lado inferior da seta acontecendo o contrário para as soldas do lado oposto.

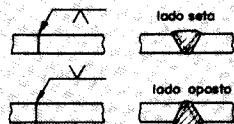

6 - Nas entalhes duplos, representar os símbolos, em ambos os lados da seta.



7 - Indicar as dimensões de uma solda somente uma vez quando em ambos os lados da emenda ela é do mesmo tipo e tamanho, caso contrário indicar as dimensões em ambos os lados.



8 - Onde somente um dos elementos sofrer entalhe, representar a seta, indicando precisamente aquele elemento com mudança brusca de direção da seta.

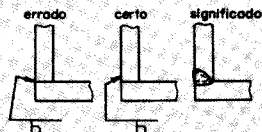

9 - Na colocação da seta na posição vertical seguir o mesmo procedimento usado para colocação de cotas.



10 - Indicar o comprimento próprio de cada solda em combinação com a linha de cota.

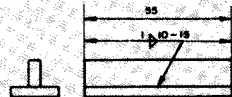

11 - Representar as soldas nas mudanças bruscas de direção conforme indica o desenho ao lado, exceto, quando se usar o símbolo de solda de contorno.



12 - Quando se quer representar o contorno real do cordão proceder da seguinte maneira:

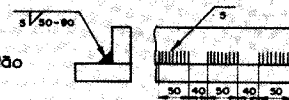

13 - Representar os símbolos com o traço vertical sempre no lado esquerdo.



14 - Representar a solda em cadeia da seguinte maneira:

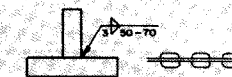

15 - Representar a solda escalonada da seguinte maneira:

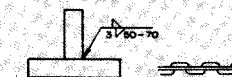

16 - Quando o cordão de solda angular, fizer um ângulo diferente de 45°, indicar da seguinte maneira:



17 - Indicar o lado em que é feita a solda de recorte reto, por meio do símbolo da solda convexo ou raso. Quando a penetração da solda não é completa, indicar a penetração.

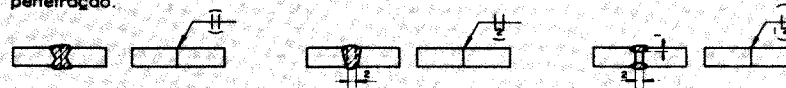

18 - Indicar a profundidade do entalhe das soldas de recorte em V ou em bisel quando o entalhe não for completo. Caso contrário dispensar a indicação.

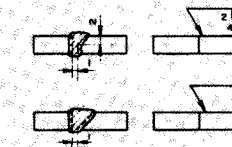

19 - Indicar as soldas de ranhura e de bujão da seguinte maneira:



20 - Indicar qualquer solda que não é feita na oficina assim:

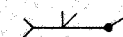

21 - Indicar as soldas em todo o contorno assim:

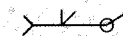

22 - Indicar solda com cordão raso, sem recurso de acabamento assim:



23 - Indicar solda com cordão raso e com acabamento utilizando os respectivos sinais de usinagem.



24 - Indicar cordão de enchimento assim:

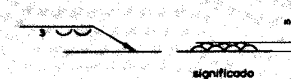

JUNTA DE TOPO

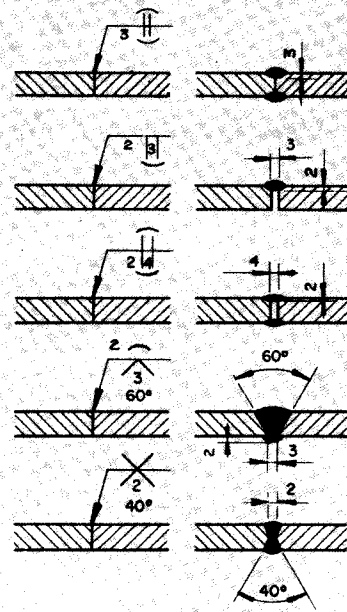

OBS.: a flecha deve indicar a peça a ser chanfrada

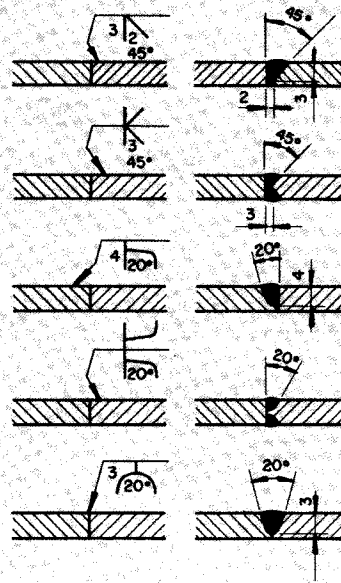

JUNTA EM T

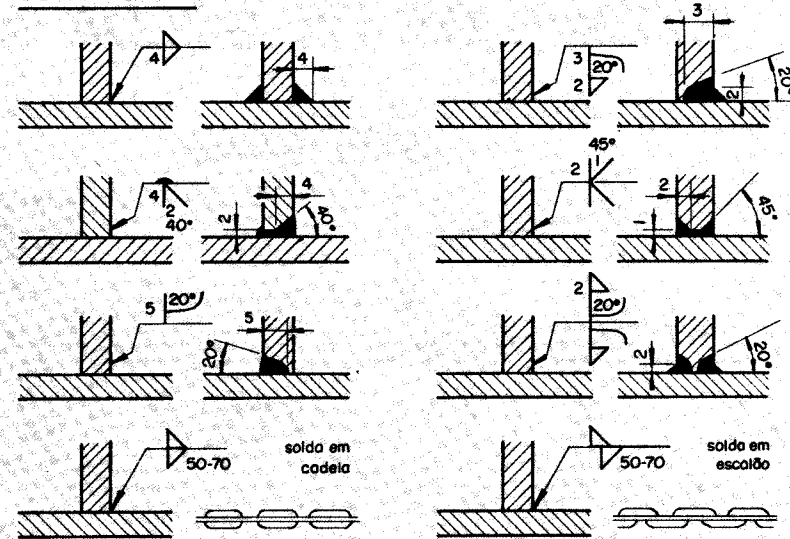

JUNTA EM ÂNGULO

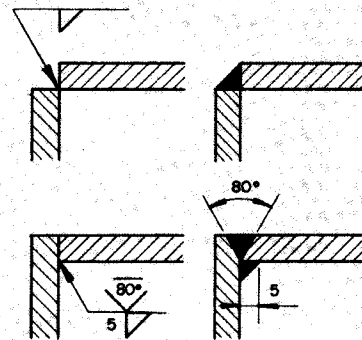
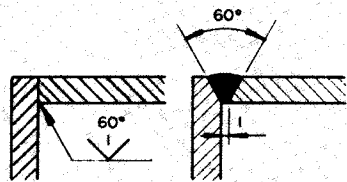

JUNTA EM ARESTA

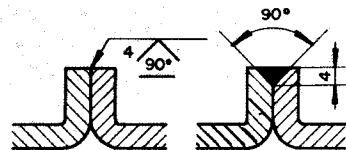
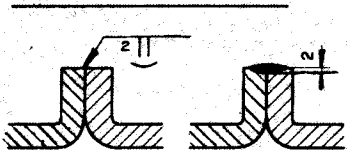

JUNTA SUPERPOSTA

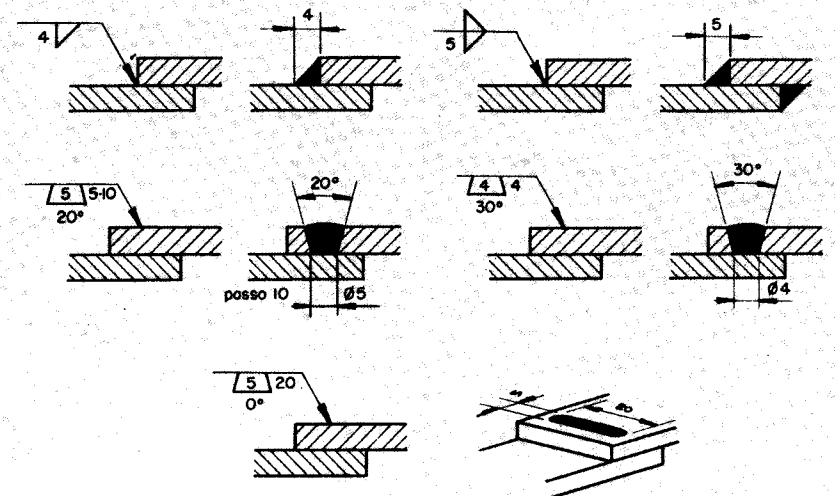

CÁLCULOS - Vide Prontuário do Projetista de Máquinas

EXEMPLOS DE SOLDA A ARCO

UNIÃO DE TUBOS

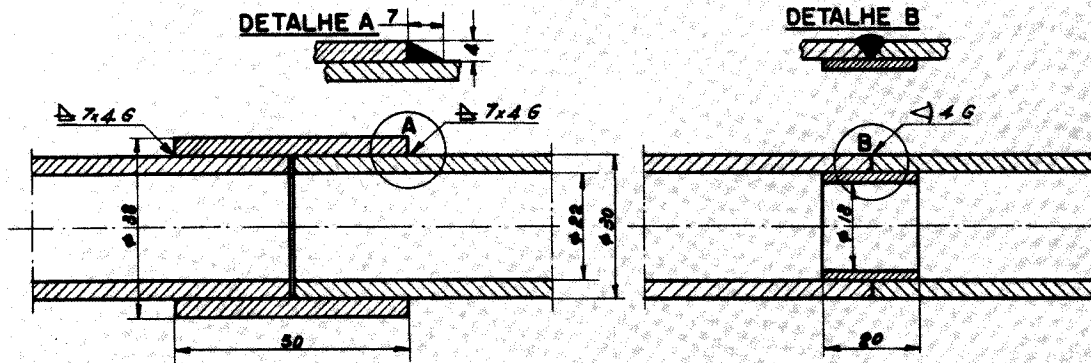

UNIÃO DE FLANGE E TUBO

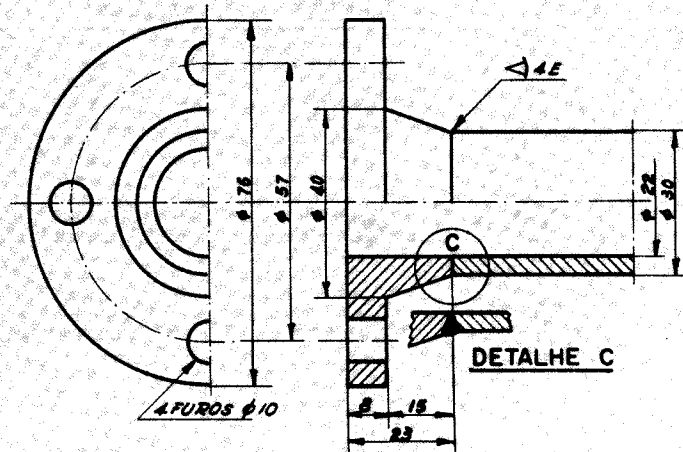

UNIÃO DE CHAPAS PARA RECIPIENTE ETC.

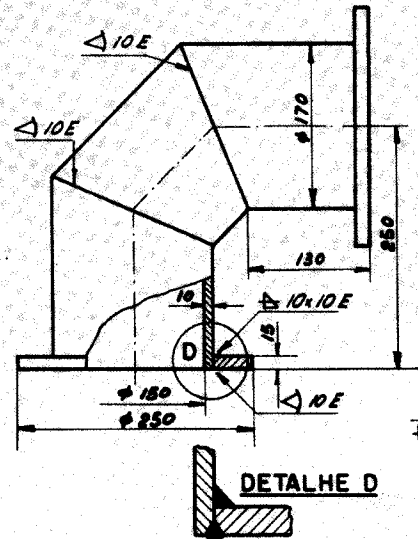
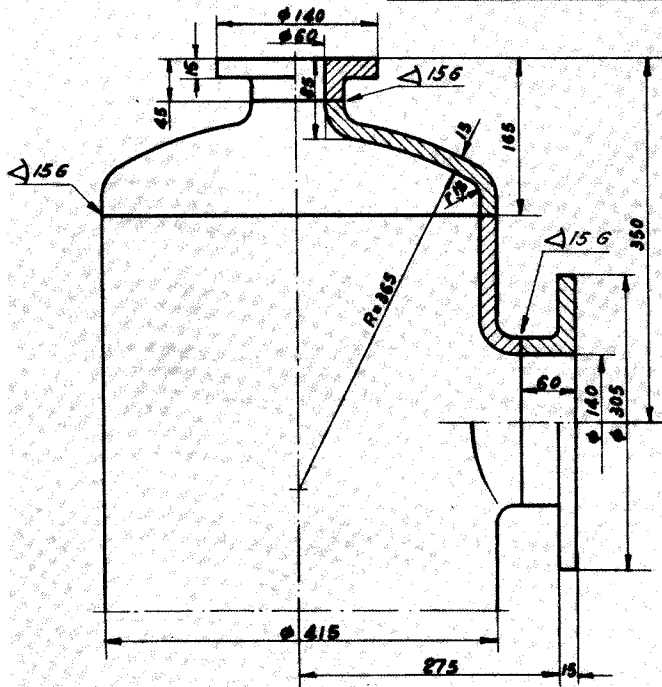

UNIÃO DE PERFIS

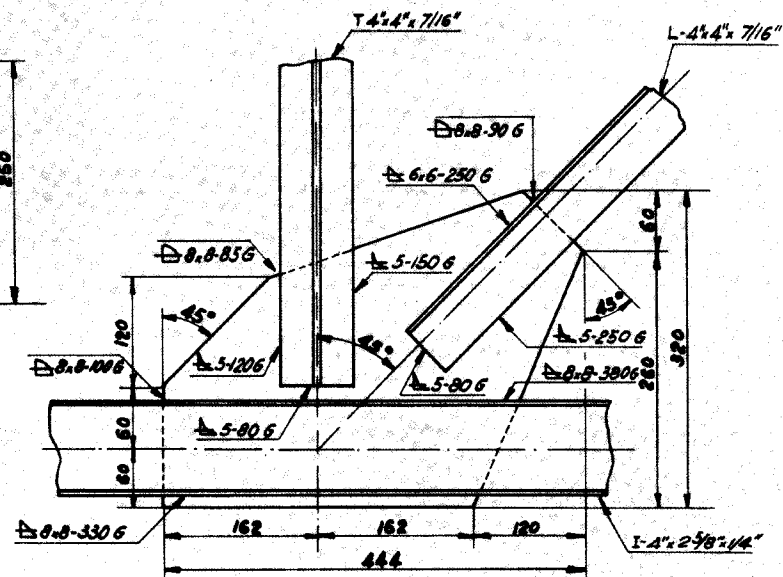

SOLDA COM RESISTÊNCIA ELÉTRICA - NORMA AMERICANA

SÍMBOLOS

Tipo de solda				solda na montagem	solda em todo o contorno	Acabamento	
por pontos	por saliências	por costura	de topo			liso	c/rebordo
*	X	XXX		●	○	—	⌒ (solda de topo)

OBSERVAÇÕES

- 1 - Na solda com resistência elétrica, a designação lado seta e lado oposto não tem significado, a não ser no caso de solda por saliências.
- 2 - Indicar as soldas com resistência elétrica pelo esforço que são capazes de resistir e não por suas dimensões.

- 3 - Representar a solda por pontos da seguinte maneira:

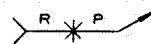

R = resistência ao cisalhamento de cada ponto em kg.
p = passo em mm

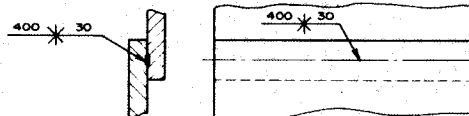

- 4 - Representar a solda por costura da seguinte maneira:

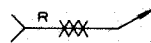

R = resistência ao cisalhamento em kg/cm de solda

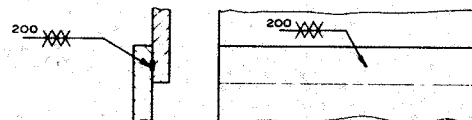

- 5 - Os símbolos de solda por pontos ou por costura podem ser usados diretamente nos desenhos.

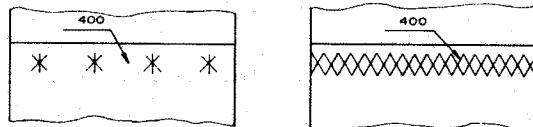

- 6 - A solda é considerada com costura, quando os pontos são tangentes ou se sobrepõem em parte. Existindo qualquer espaço entre os pontos, será considerada por pontos em série e, neste caso, empregar-se-á o símbolo da solda por pontos.

- 7 - Representar a solda por saliências da seguinte maneira:

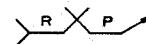

R = resistência ao cisalhamento de cada saliência em kg.

p = distância de centro a centro de lances em mm.

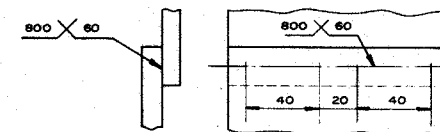

- 8 - Indicar na solda por saliências a lado que fica em relevo da seguinte maneira:

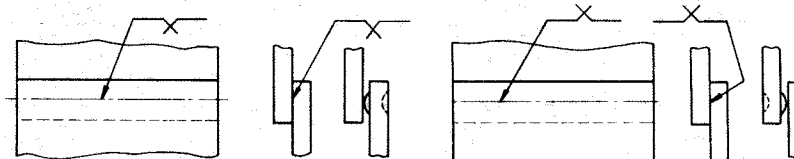

elevação

perfil significado

elevação

perfil significado

- 9 - Representar a solda de topo da seguinte maneira:

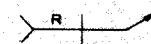

R = resistência à tração em kg/cm²

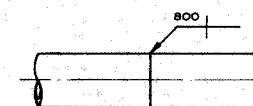

- 10 - Quando a resistência à tração da solda de topo for igual à resistência da seção do metal soldado, a indicação de R pode ser dispensada.

- 11 - Indicar o acabamento (solda lisa ou com rebordo) das soldas com resistência elétrica, obedecendo o significado do lado seta e lado oposto, da seguinte maneira:

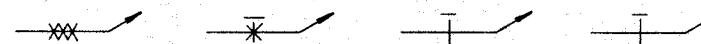

EXEMPLOS DE SOLDA COM RESISTÊNCIA ELÉTRICA

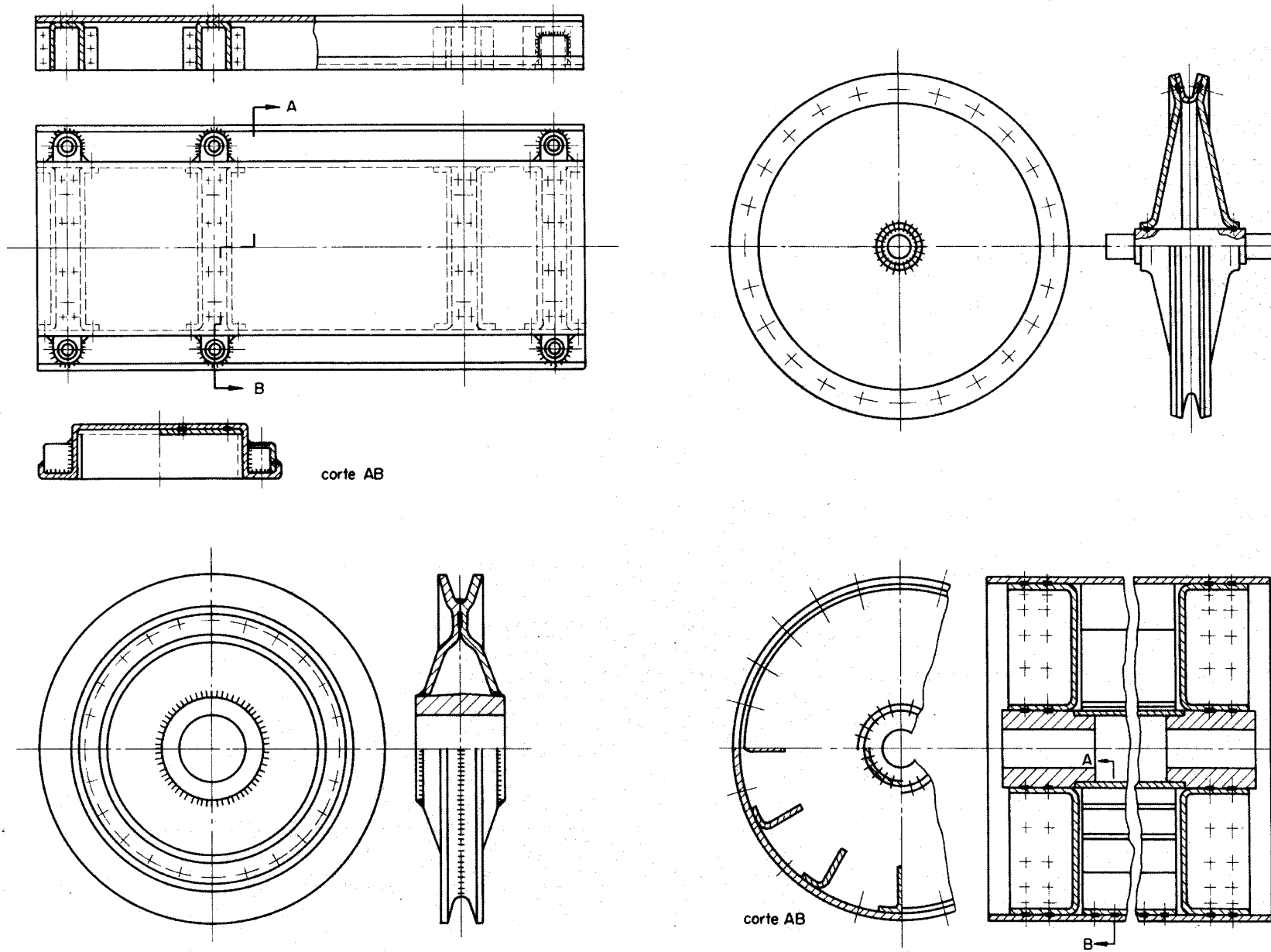

SOLDA A ARCO

SOLDA COM RESISTÊNCIA

COMPARAÇÃO

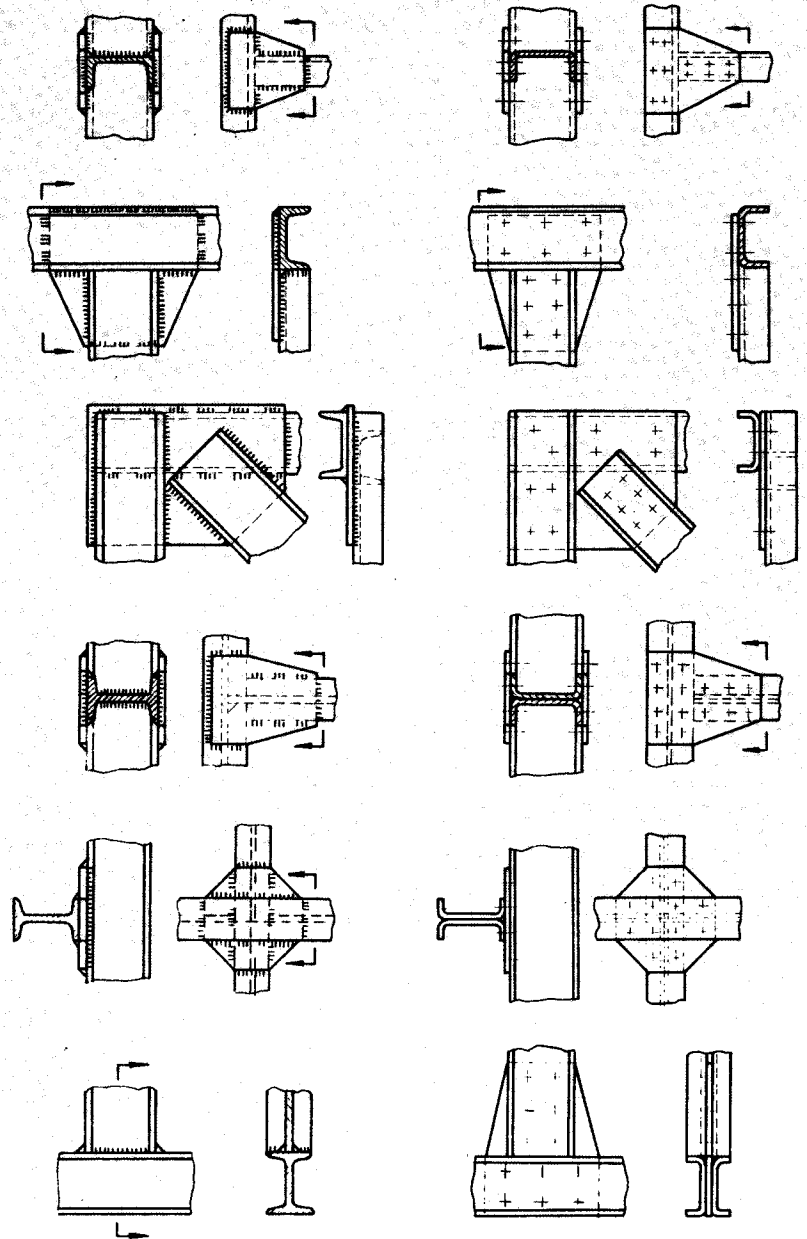

SOLDA A ARCO

SOLDA COM RESISTÊNCIA

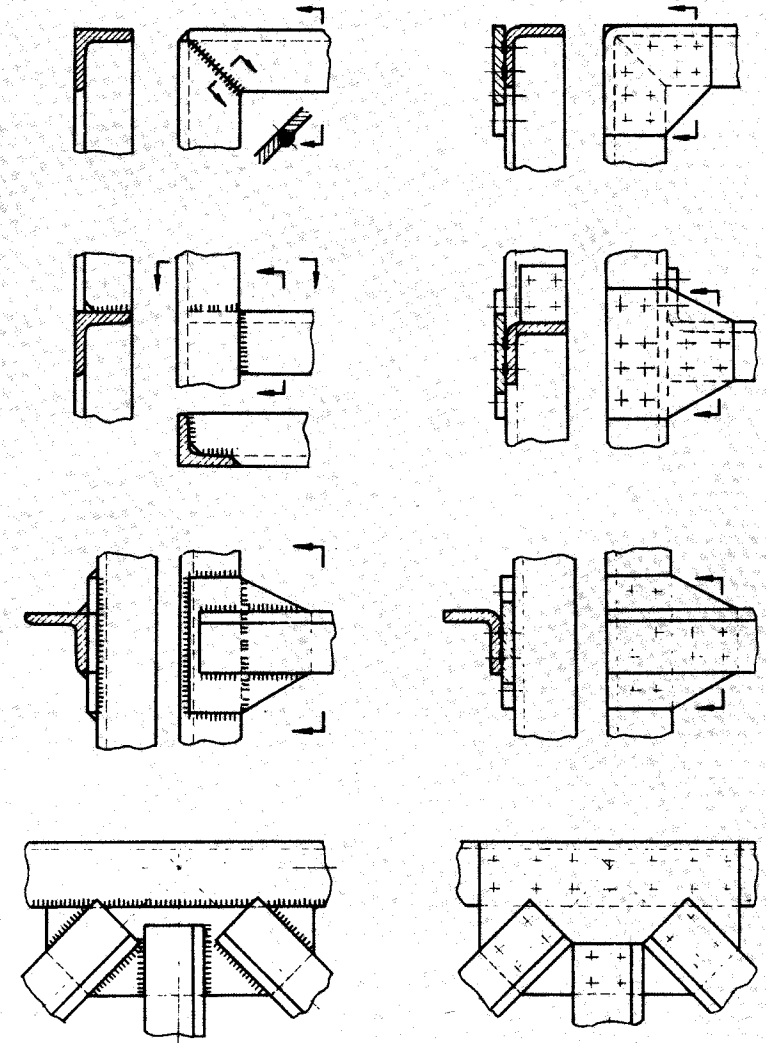

EXEMPLOS DE APLICAÇÃO

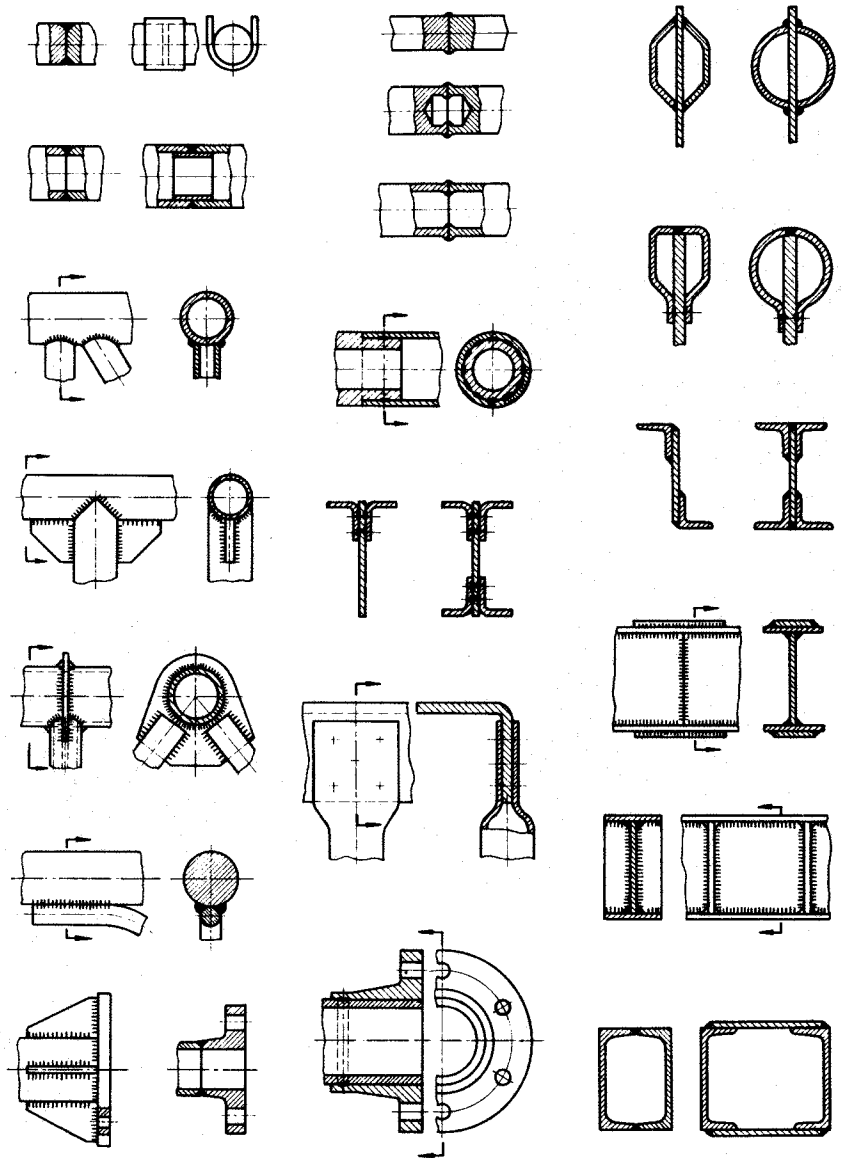

SOLUÇÕES

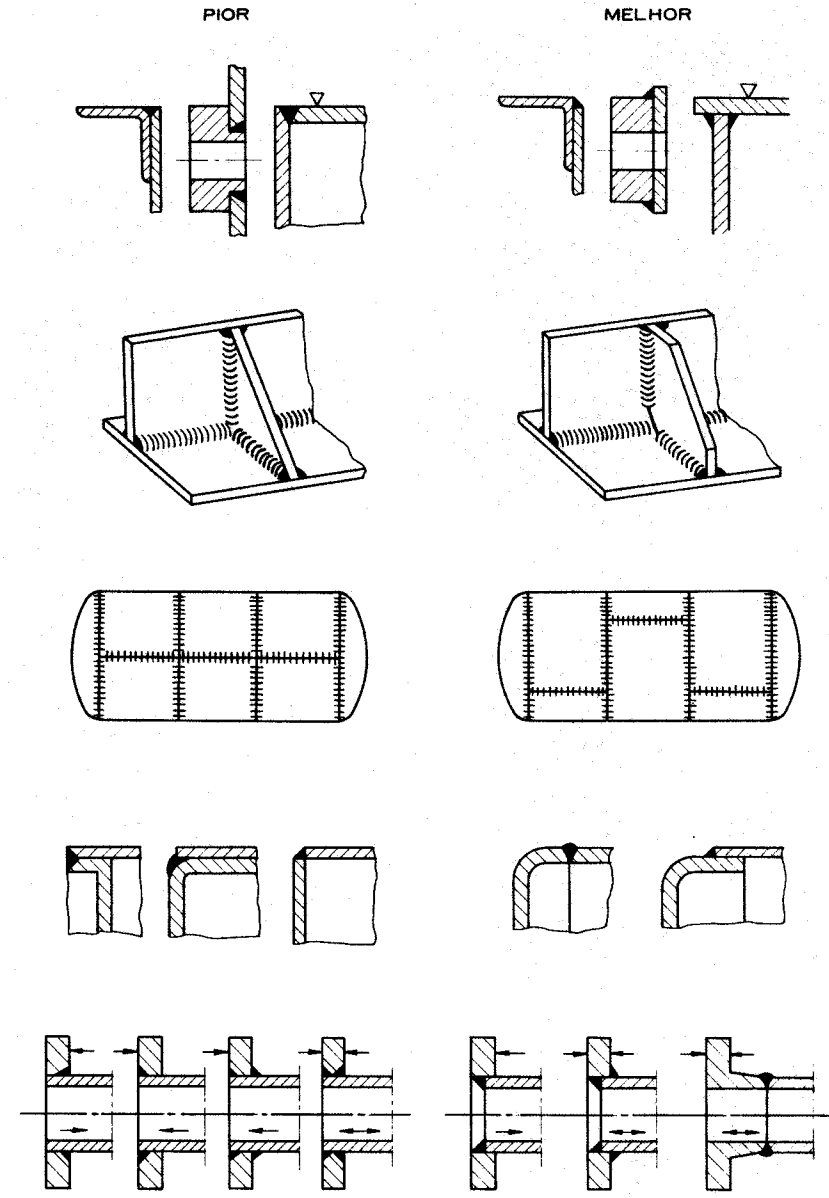

POLIAS

POLIA ESCALONADA

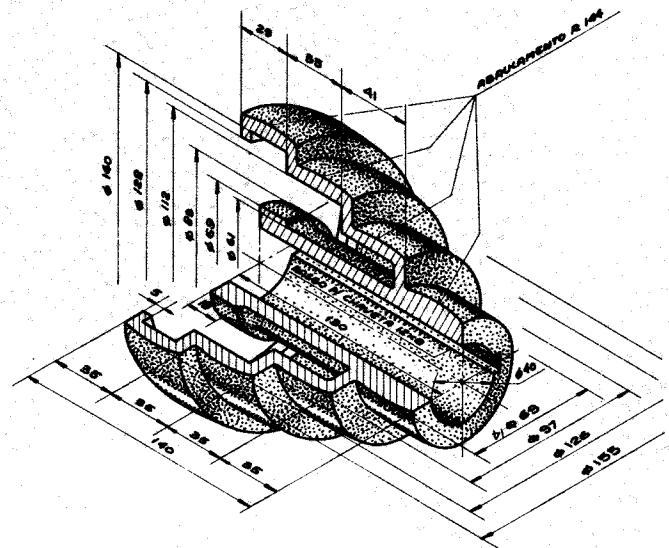

POLIA SECCIONADA

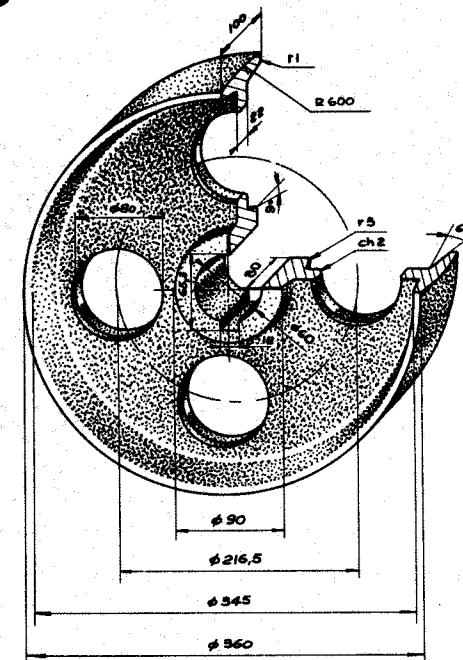
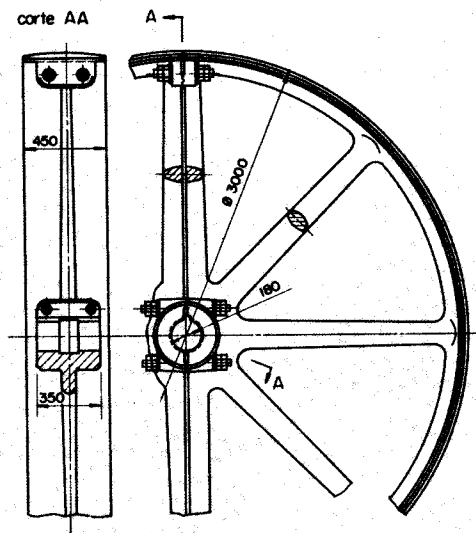

POLIA PARA CORREIA PLANA

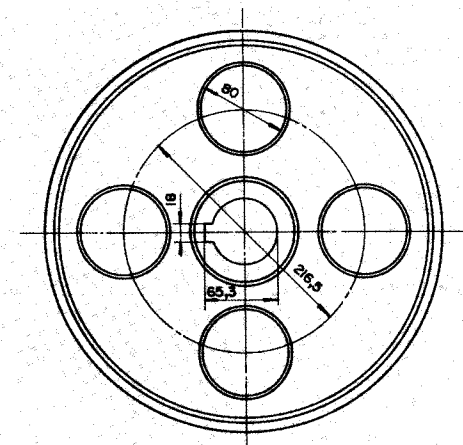
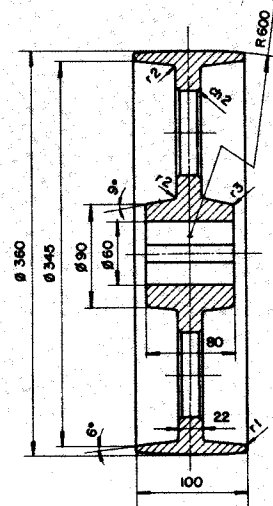
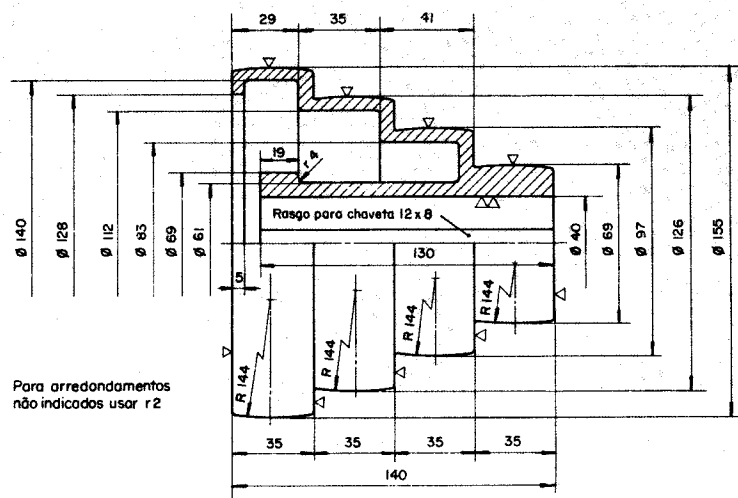

POLIA PARA CABO DE AÇO

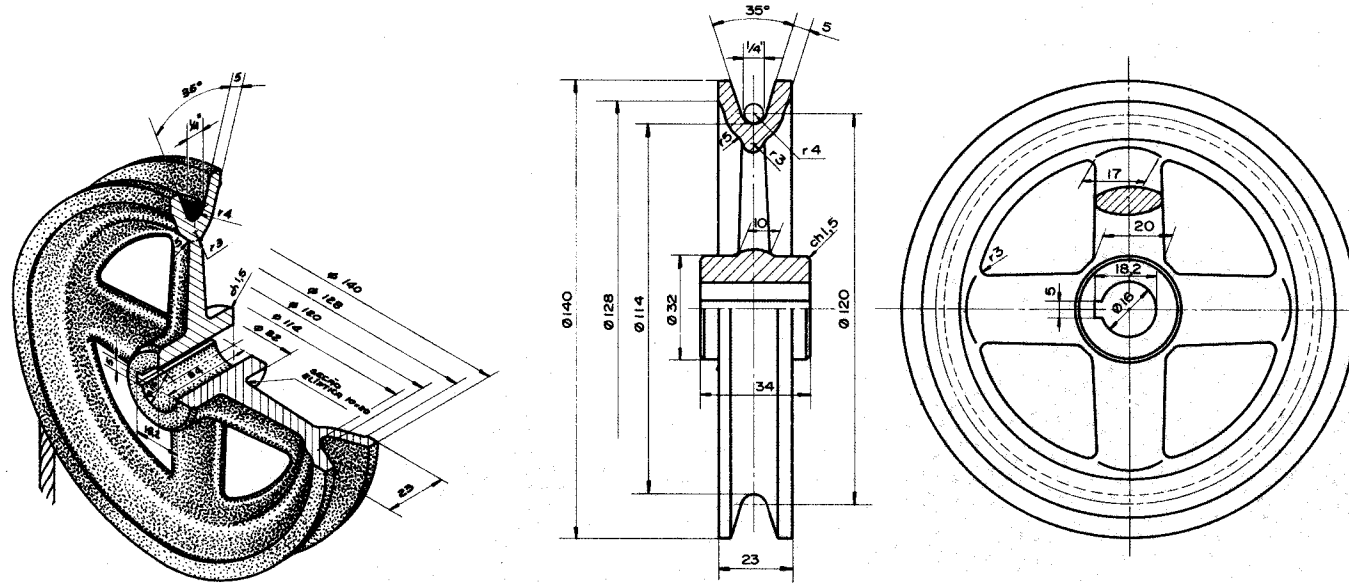

POLIA PARA CORREIAS V

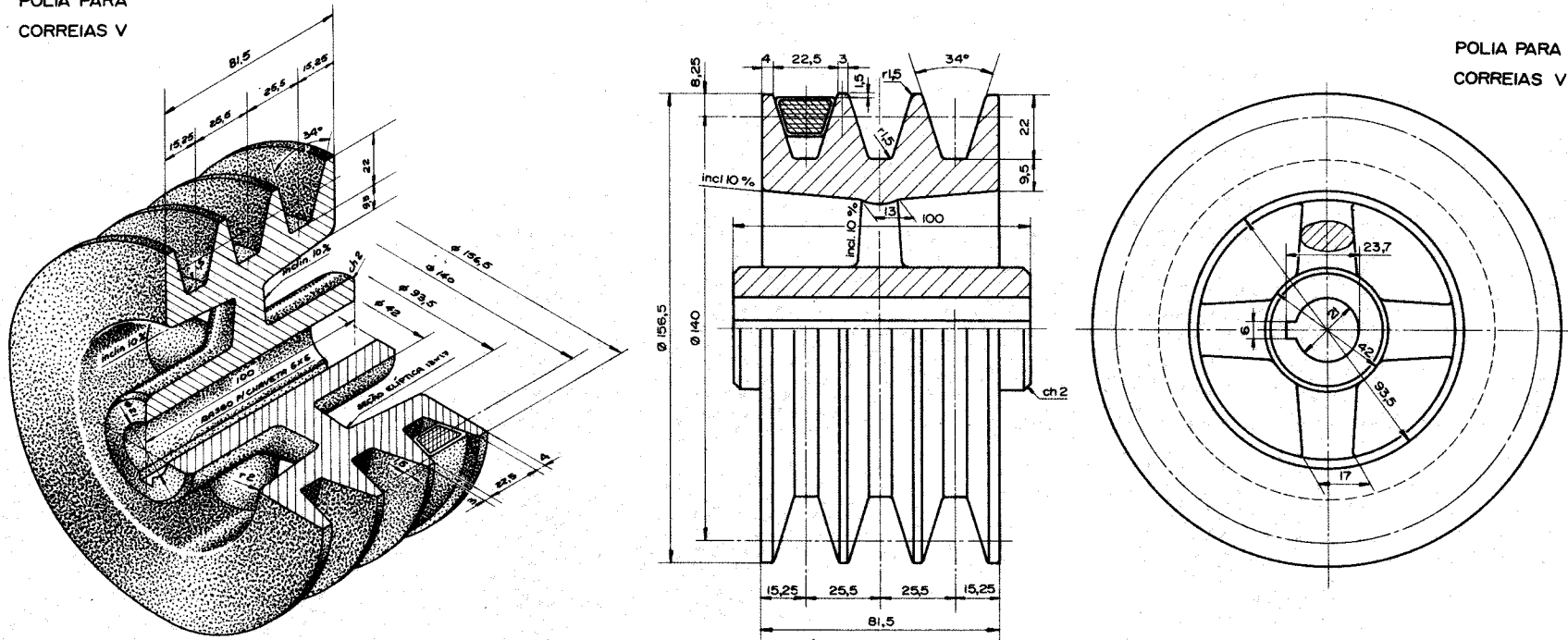

POLIA PARA CORREIAS V

ESTICADORES DE CORREIA

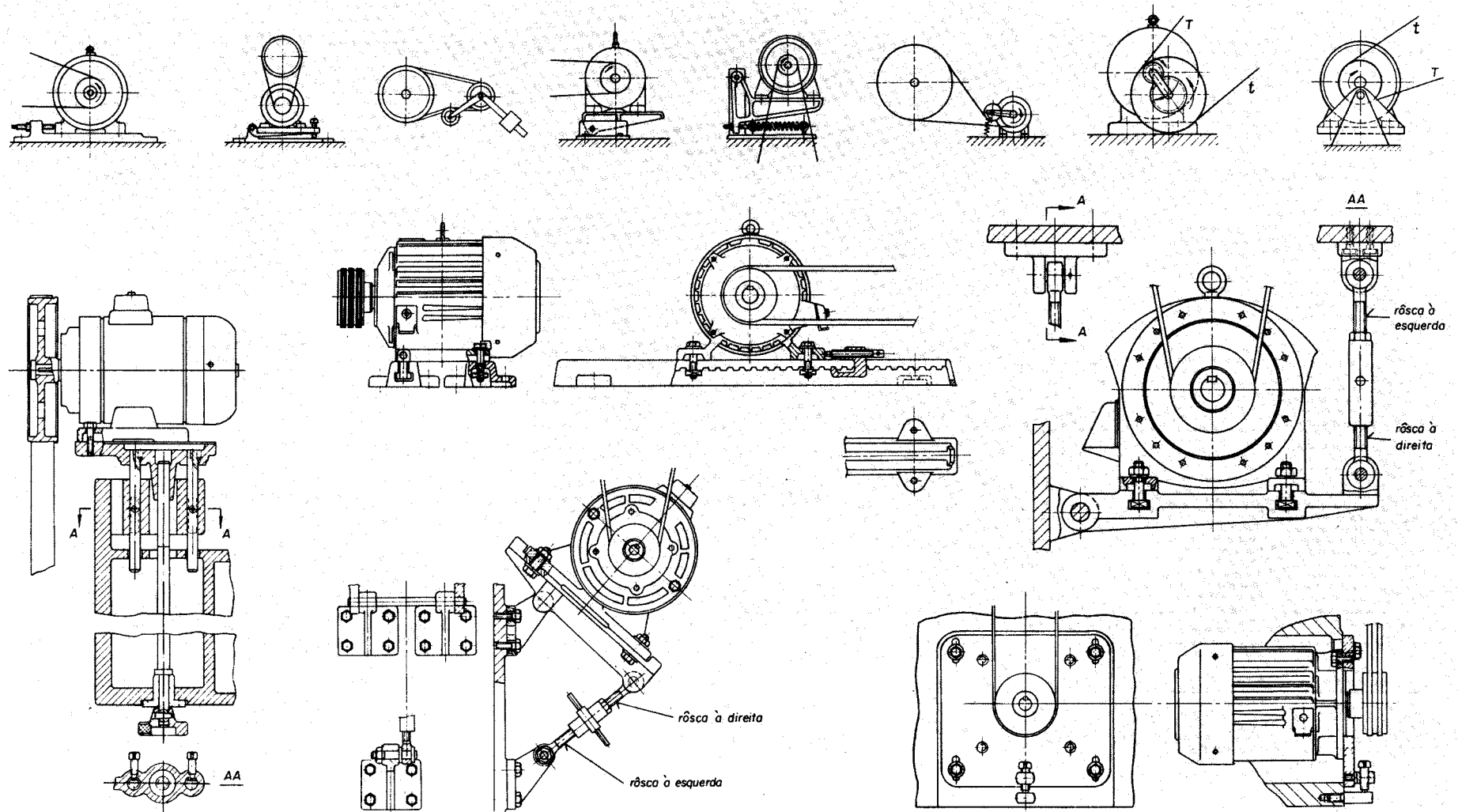

CORRENTES

ELO CURTO

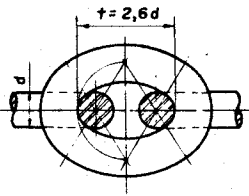

ELO INTERMEDIÁRIO

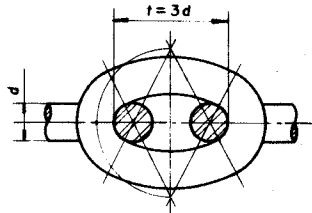

ELO COM TRAVESSA

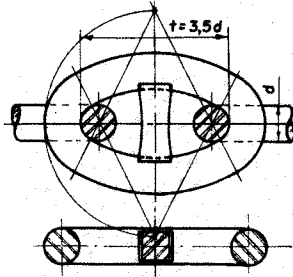

ELO COMPRIDO

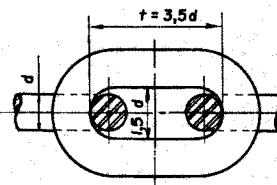

GANCHO DE AMARRAÇÃO

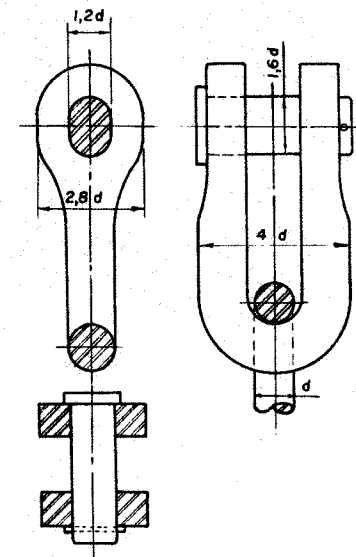

CORRENTE DE ELOS DESMONTÁVEIS

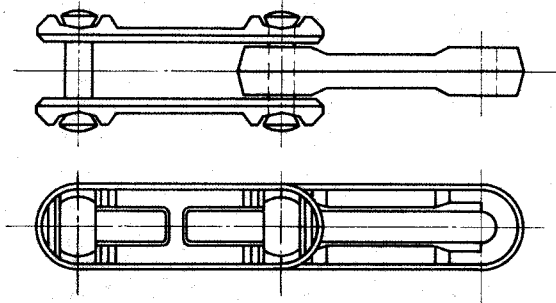

CORRENTE "WAUCANSON"

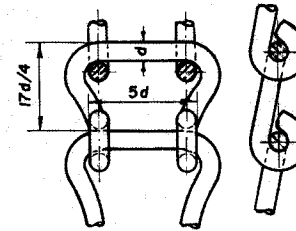

ELO DE LIGAÇÃO

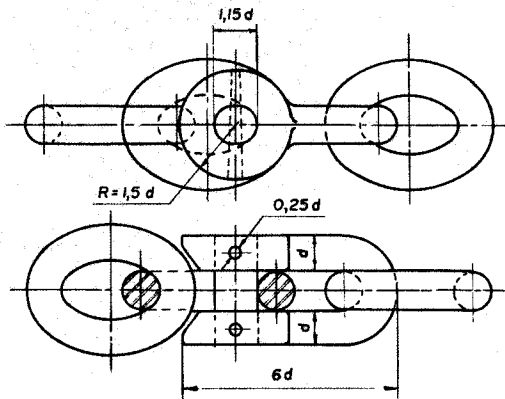

GANCHO DE AMARRAÇÃO

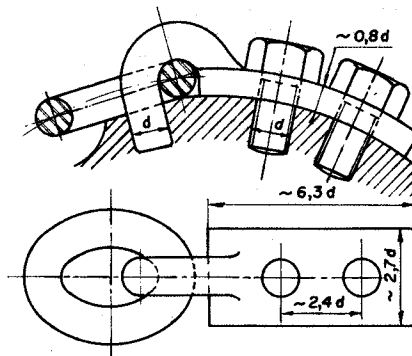

CORRENTE "GALLE"

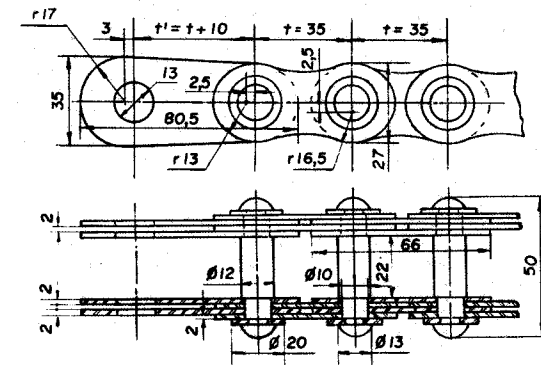

RODAS PARA CORRENTE

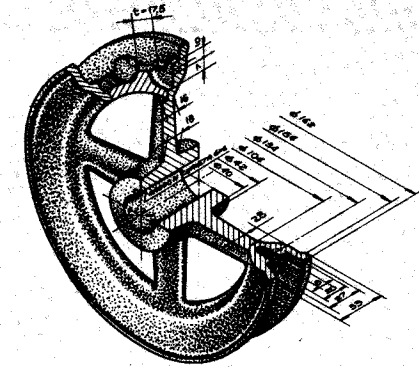
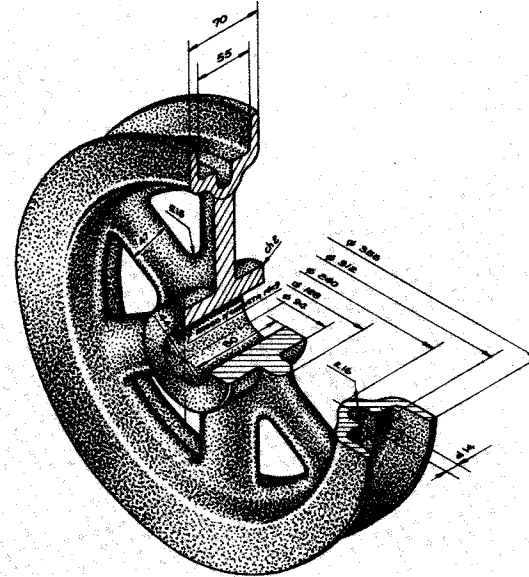
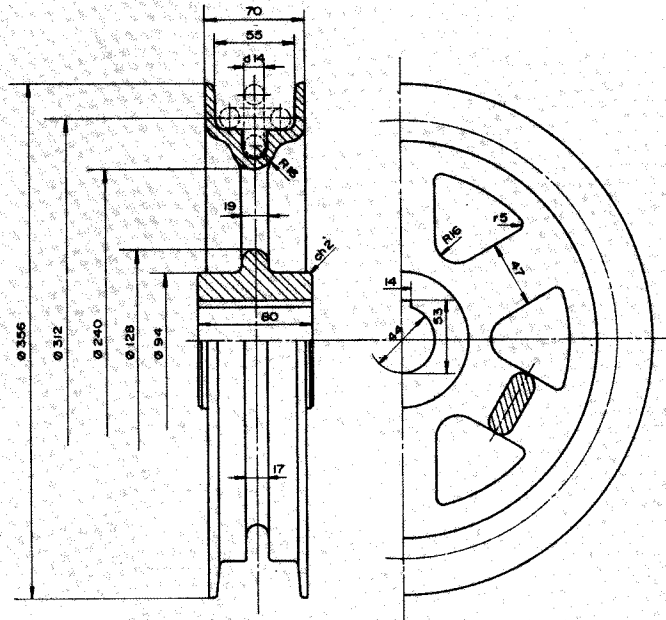

z = 12 dentes
t = 17,5
d = 5

$$D = \sqrt{\left(\frac{t}{\sin \frac{30^\circ}{2}}\right)^2 + \left(\frac{d}{\cos \frac{30^\circ}{2}}\right)^2} = 134$$

z > 4

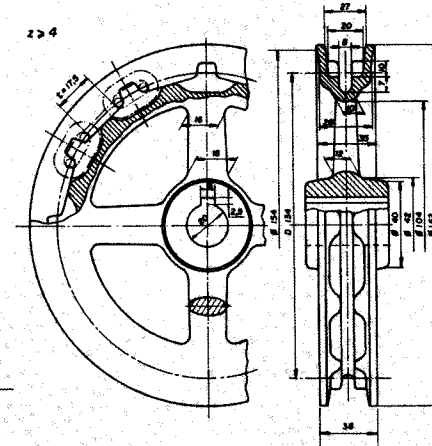

z = 8 dentes
t = 4,5
d = 17
 $D = \frac{t}{\sin \frac{30^\circ}{2}} = 118$

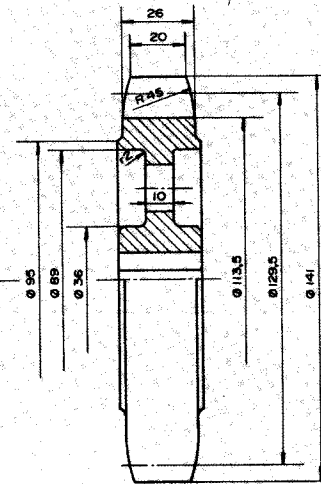
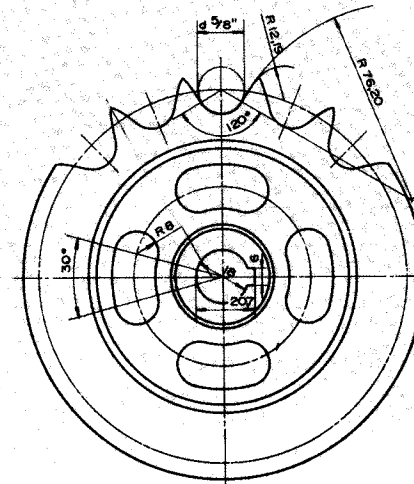
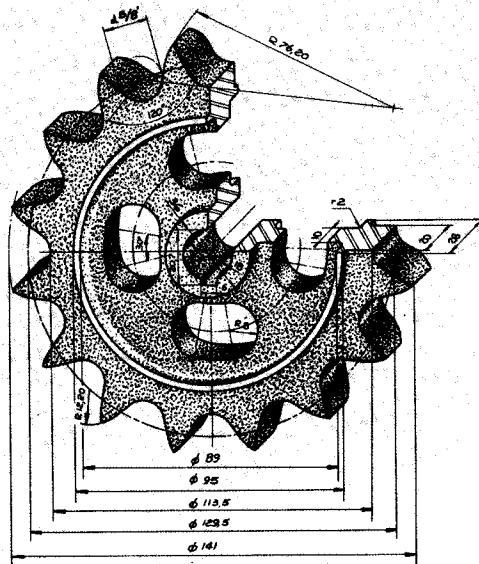
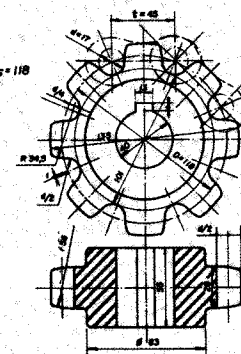

ESTICADORES DE CORRENTE

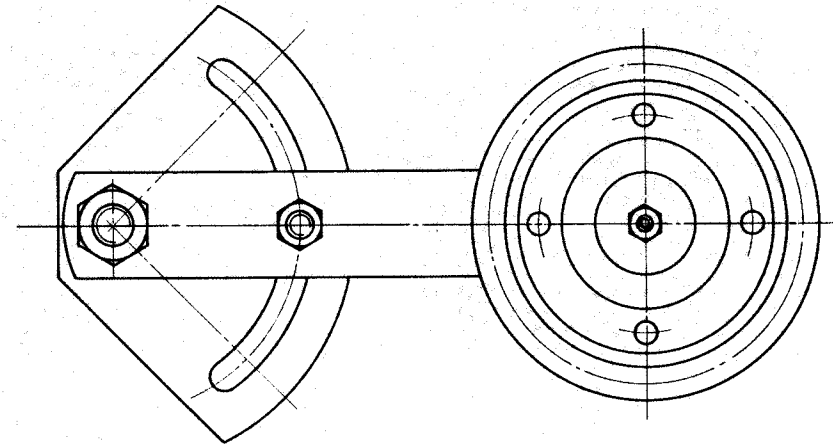
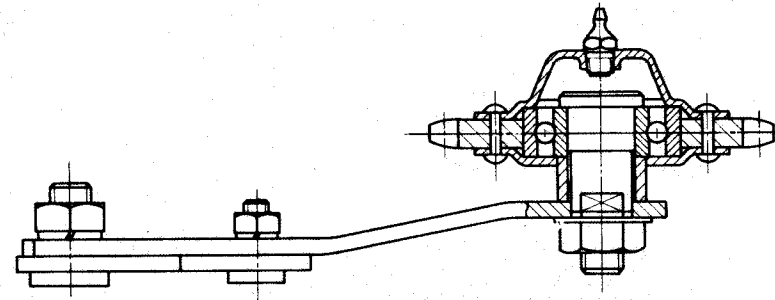
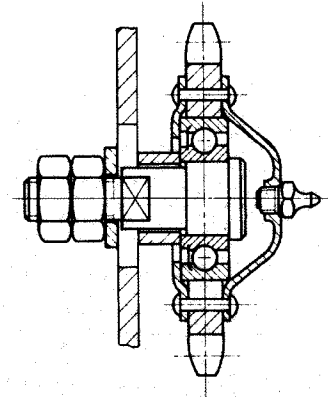
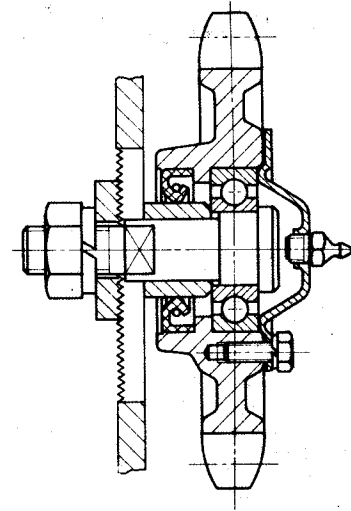
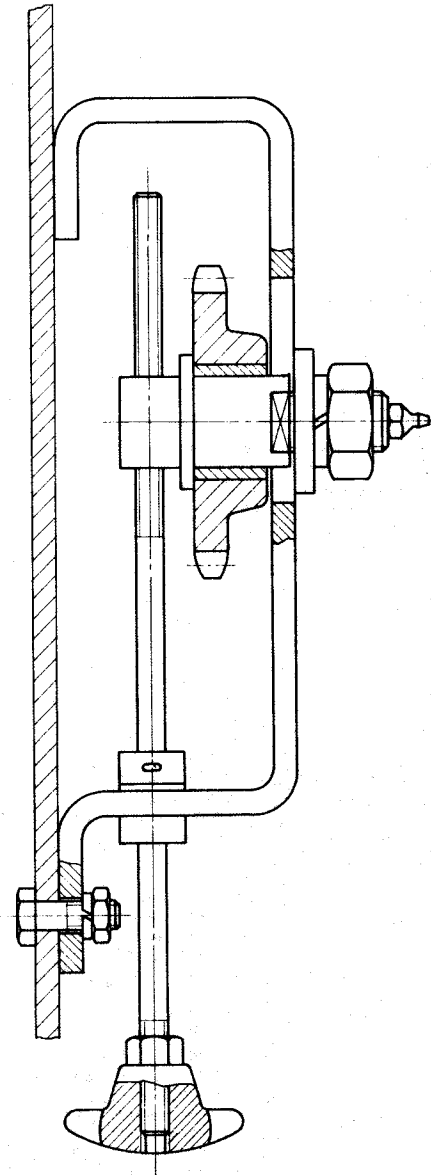
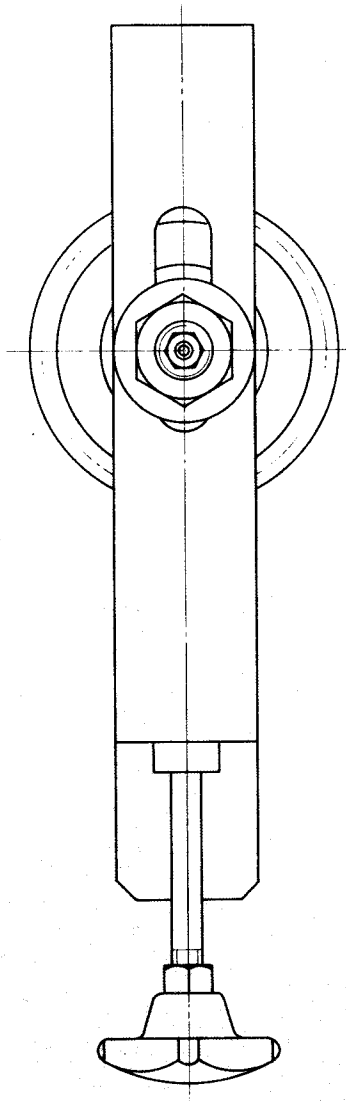

GANCHO FORJADO

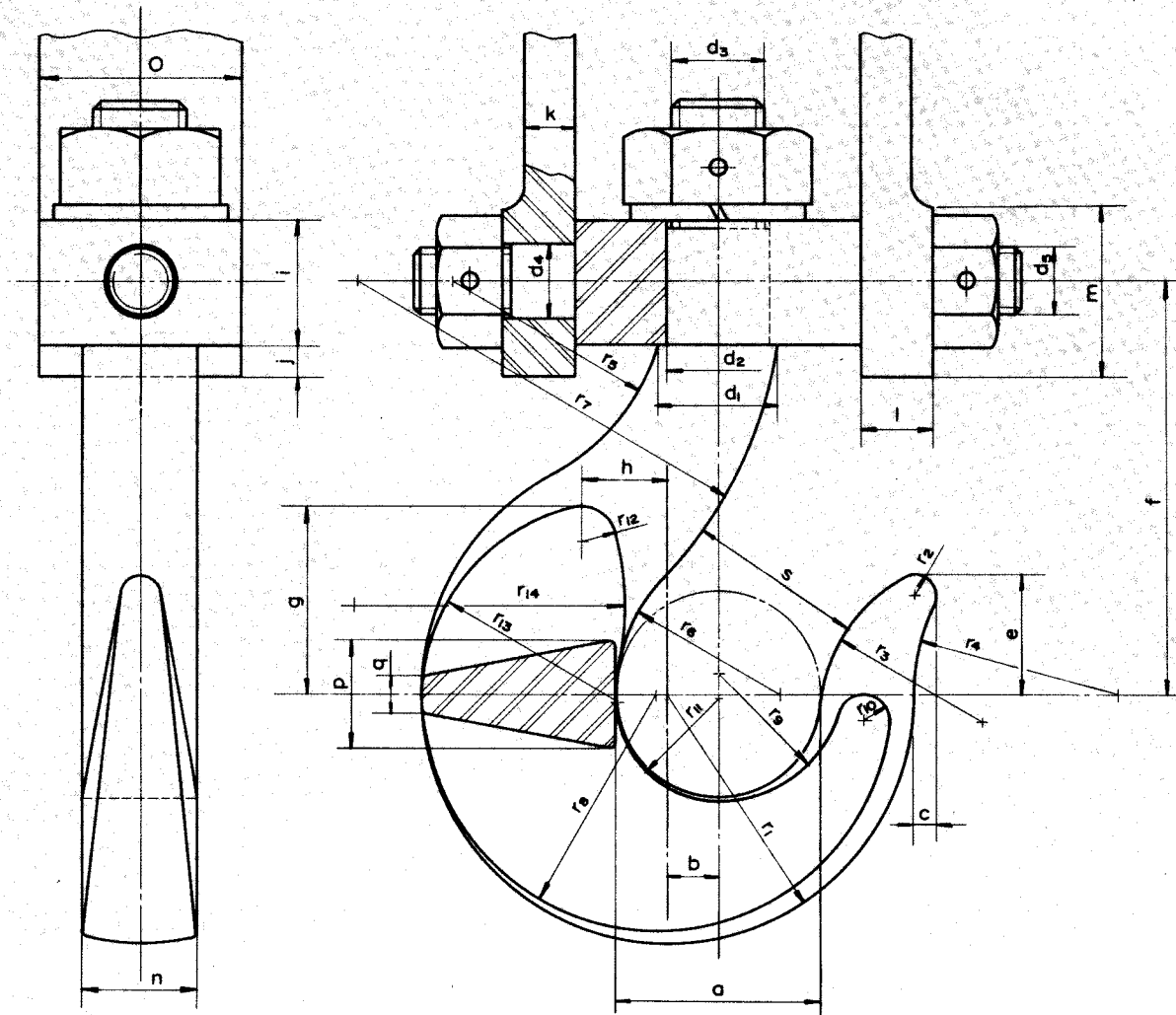

Proporções em função de

$$a = \frac{7}{5} \sqrt{P} \quad P = \text{carga em kg}$$

a	$\frac{7}{5} \sqrt{P}$	r ₁₂	0,170 a
b	0,250 a	r ₁₃	0,970 a
r ₁	1,200 a	r ₁₄	1,330 a
c	0,100 a	d ₁	0,580 a
e	0,580 a	d ₂	0,500 a
r ₂	0,100 a	d ₃	0,464 a
r ₃	0,800 a	i	0,607 a
r ₄	1,000 a	j	0,150 a
f	2,000 a	k	0,250 a
r ₅	1,060 a	l	0,357 a
r ₆	0,800 a	m	0,800 a
r ₇	2,090 a	d ₄	0,357 a
r ₈	1,150 a	d ₅	0,321 a
r ₉	0,625 a	n	0,571 a
r ₁₀	0,120 a	o	1,000 a
r ₁₁	0,500 a	p	0,536 a
g	0,910 a	q	0,179 a
h	0,420 a	s	0,833 a

GANCHO FORJADO DUPLO

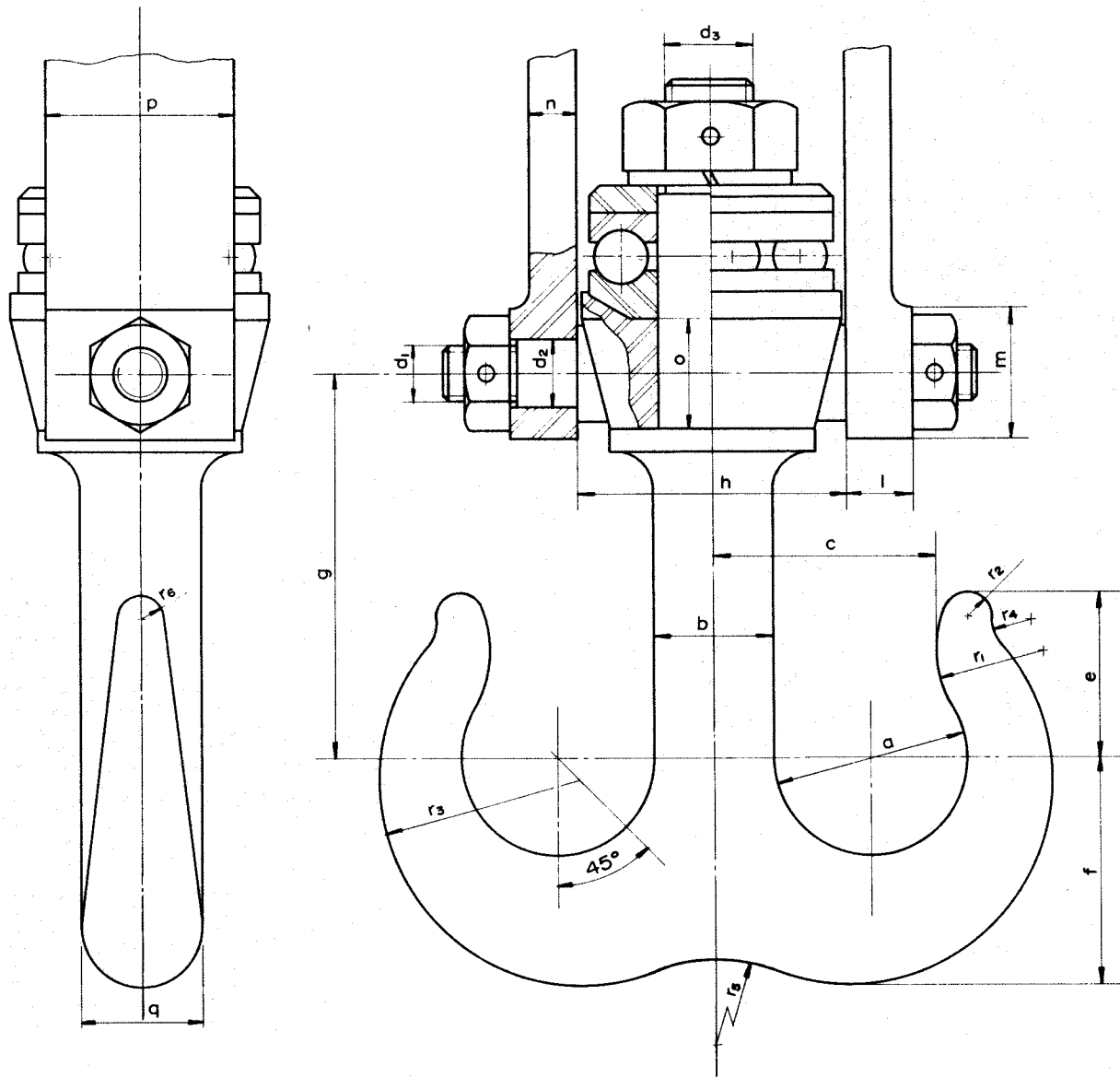

Proporções em função de

$$a = \frac{7}{5} \sqrt{P} \quad P = \text{carga em kg}$$

a	$7/5 \sqrt{P}$	h	1,428 a
b	0,625 a	l	0,357 a
c	1,165 a	m	0,679 a
r ₁	0,562 a	n	0,250 a
e	0,857 a	d ₁	0,300 a
r ₂	0,120 a	d ₂	0,355 a
f	1,172 a	o	0,571 a
r ₃	1,062 a	d ₃	0,469 a
r ₄	0,212 a	p	1,000 a
r ₅	0,937 a	q	0,625 a
g	≤ 2,000 a	r ₆	0,120 a

CATRACAS

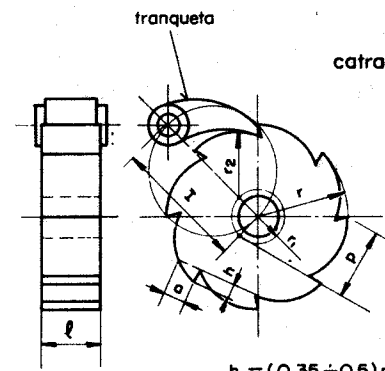
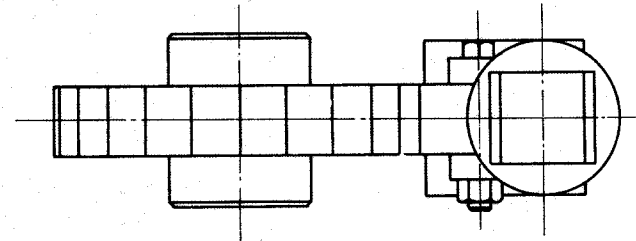
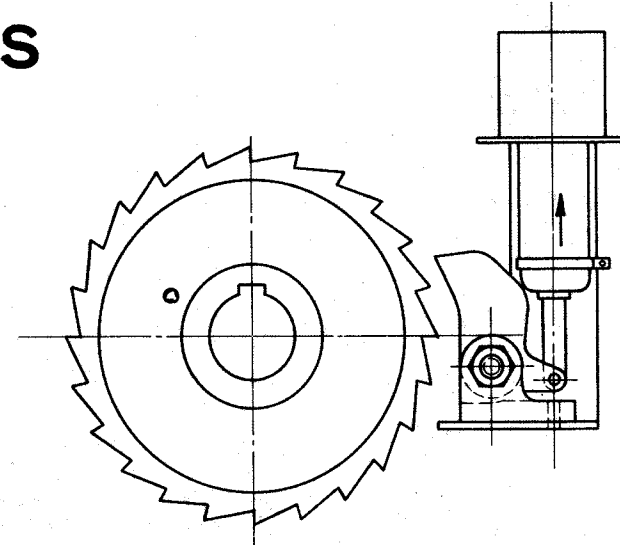
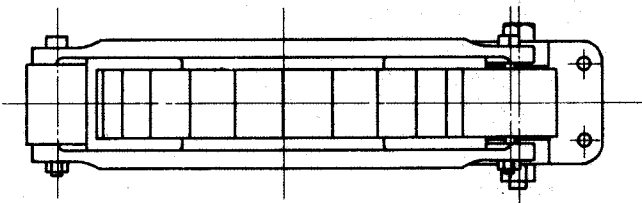
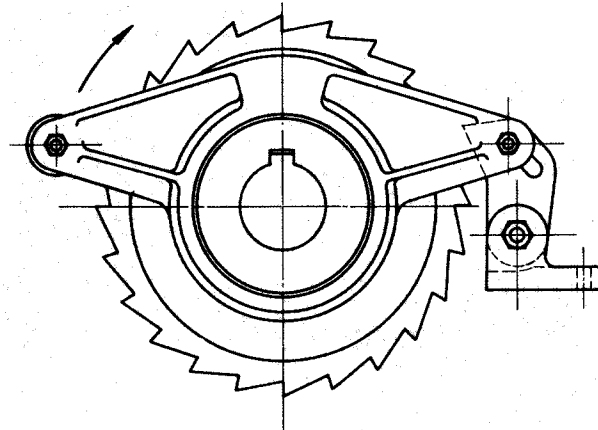

catracas externas

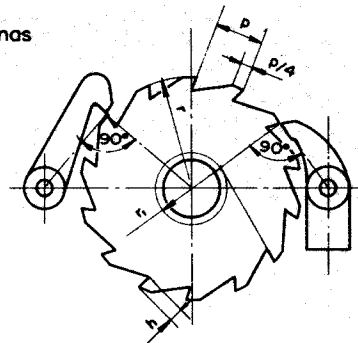

diâmetro \geq 200 mm
da catraca

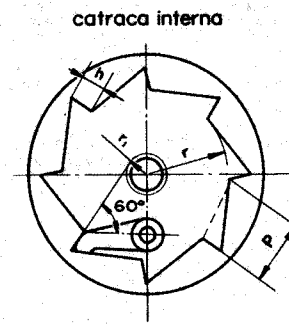

catraca interna

$r_1 = 0,3r$
 $h = 0,35p$

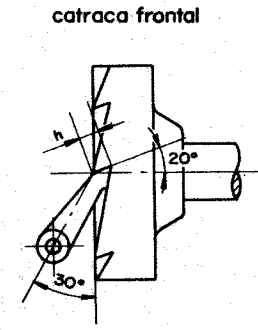

catraca frontal

$h = (0,3 - 0,35)p$

$h = (0,35 \pm 0,5)p$
para $z = 8 \div 14$ dentes $r_1 = 0,3r$
 $l = (0,5 \div 1,25)p$ $a = 0,5p$

CAMES

CAME ROTATIVO

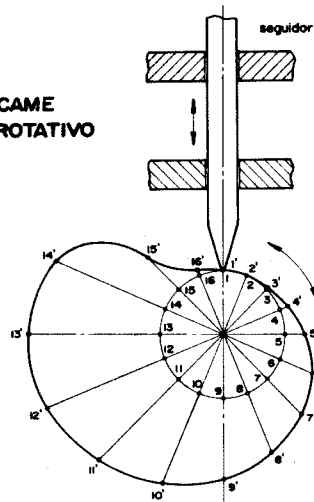

CAME DESLIZANTE

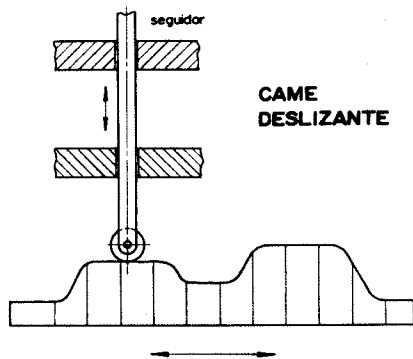

DEFINIÇÃO

Came é um mecanismo com superfície de forma especial, destinado a produzir um movimento particular num segundo elemento, denominado seguidor.

NOTA

O diagrama da came representa o perfil da came deslizante.

Diagrama da came

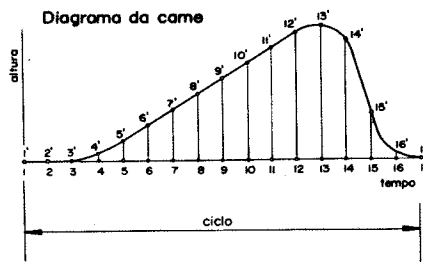

CAME ROTATIVO

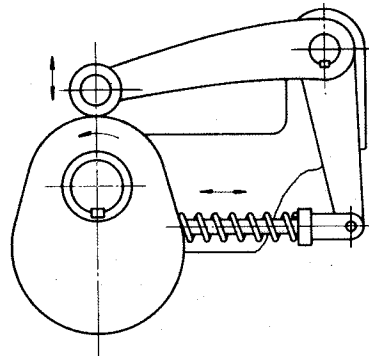

CAME DE GAVETA

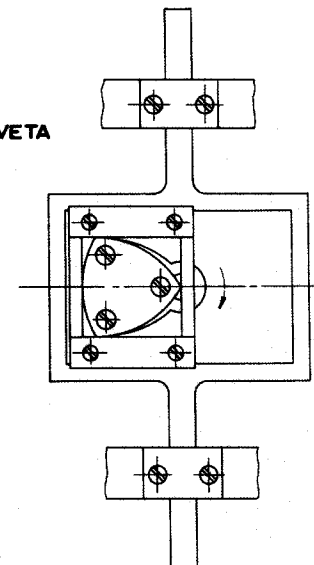

CAME DE GAVETA

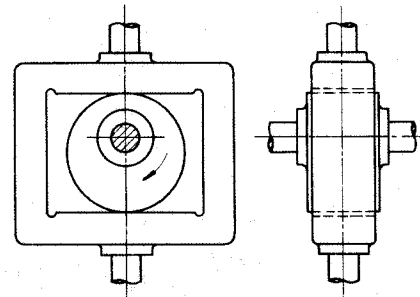

CAME ROTATIVO

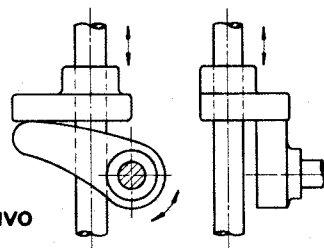

CAME ROTATIVO

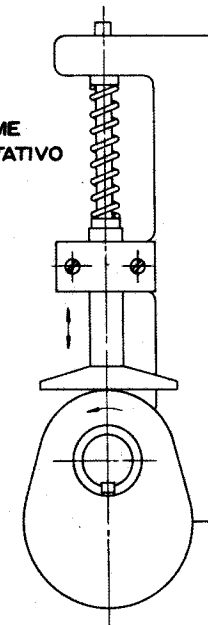

CAME DE FACE

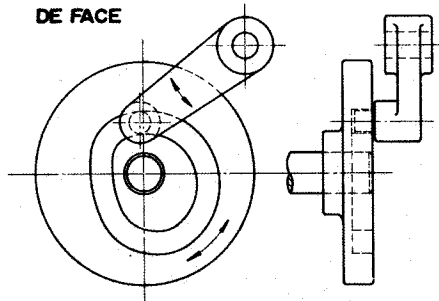

CAME CILÍNDRICO DE EXTREMIDADE

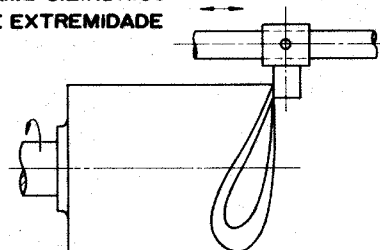

CAME CILÍNDRICO DE RANHURA

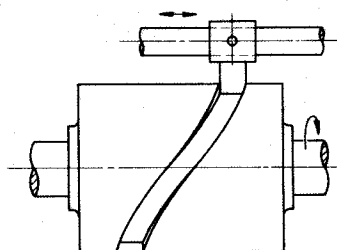

ALAVANCAS DE COMANDO

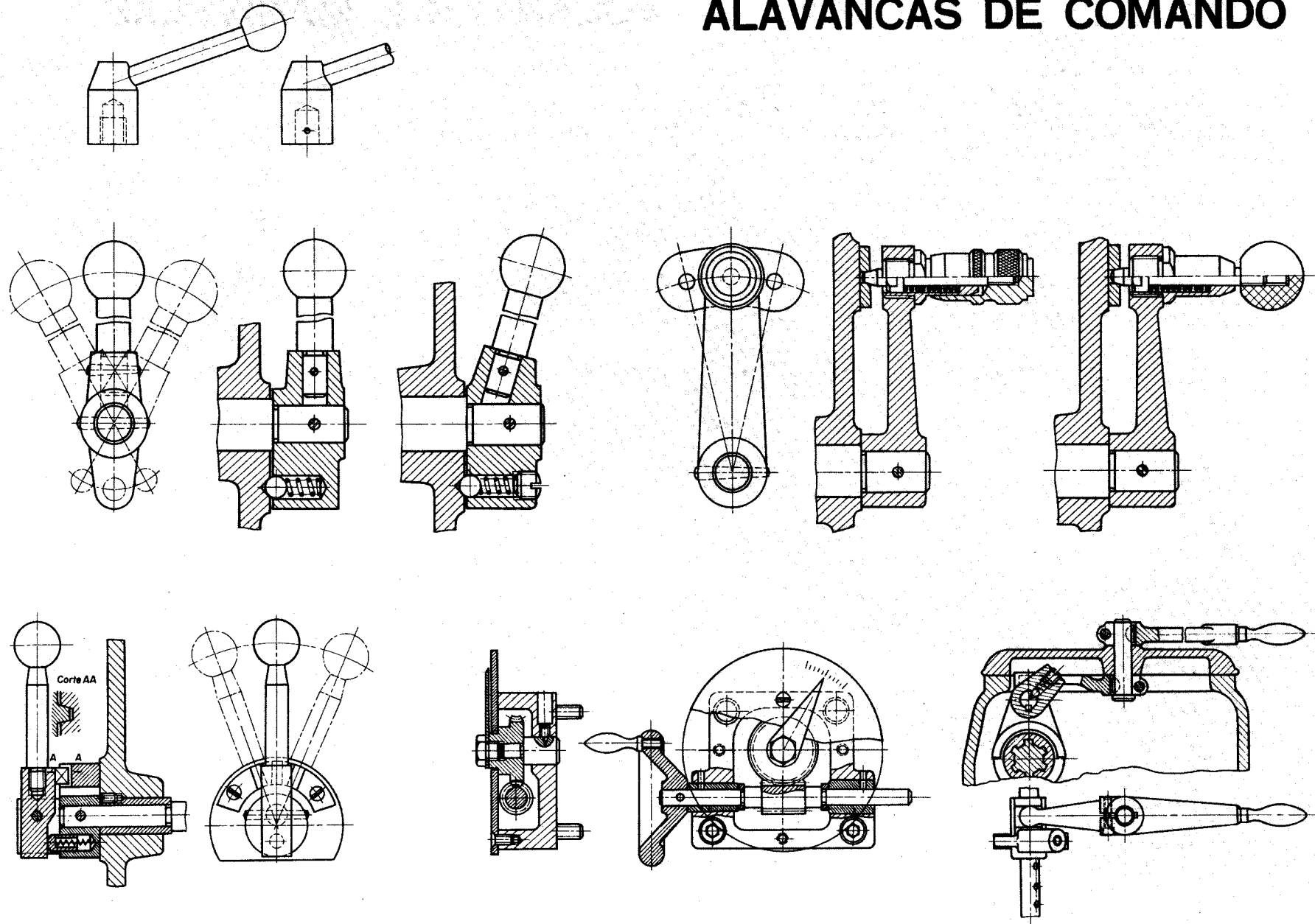

VOLANTES E MANIVELAS

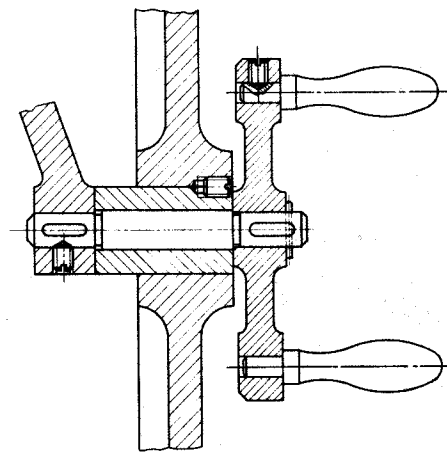
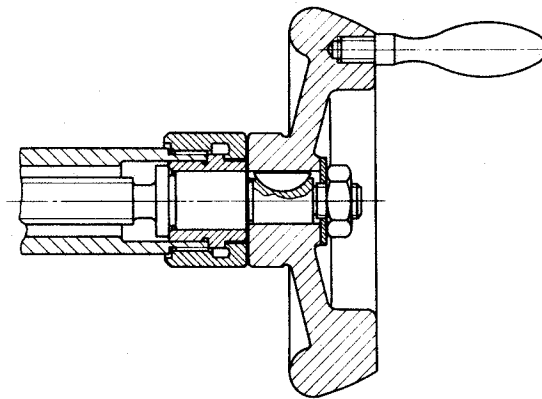
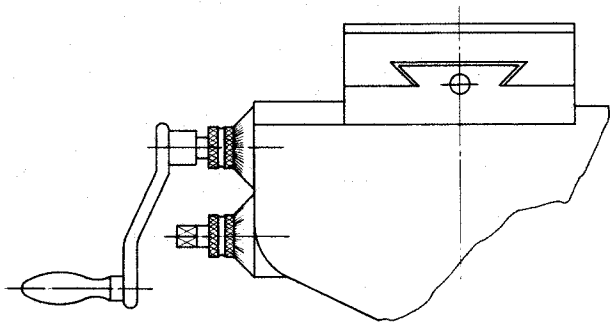
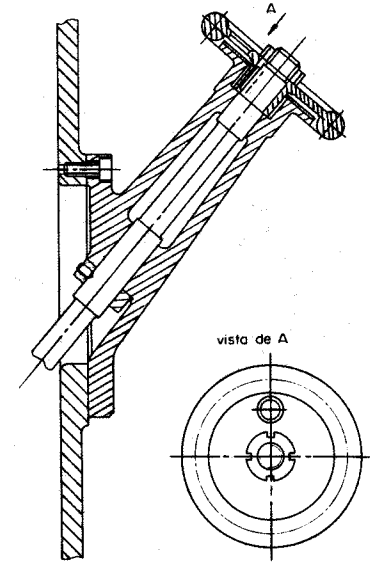
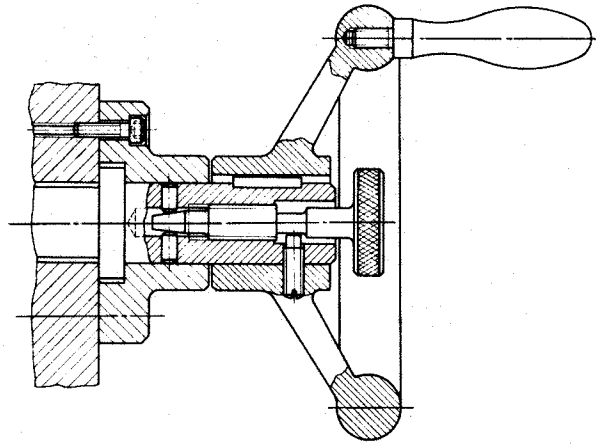
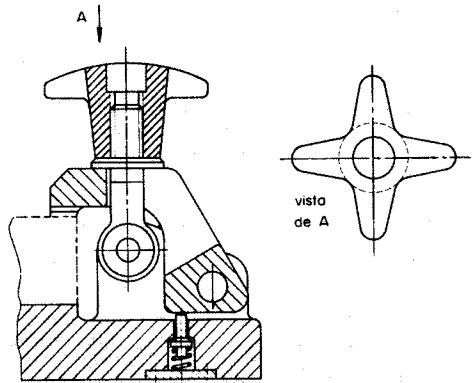
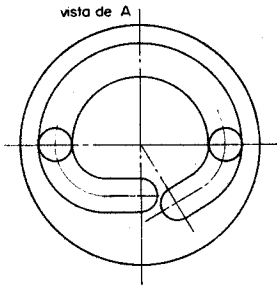
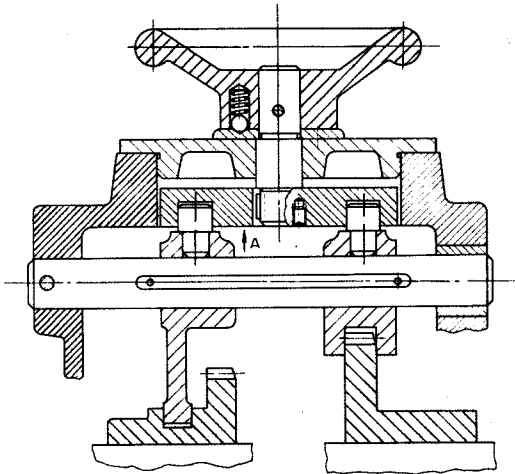

DISPOSITIVOS DE FIXAÇÃO

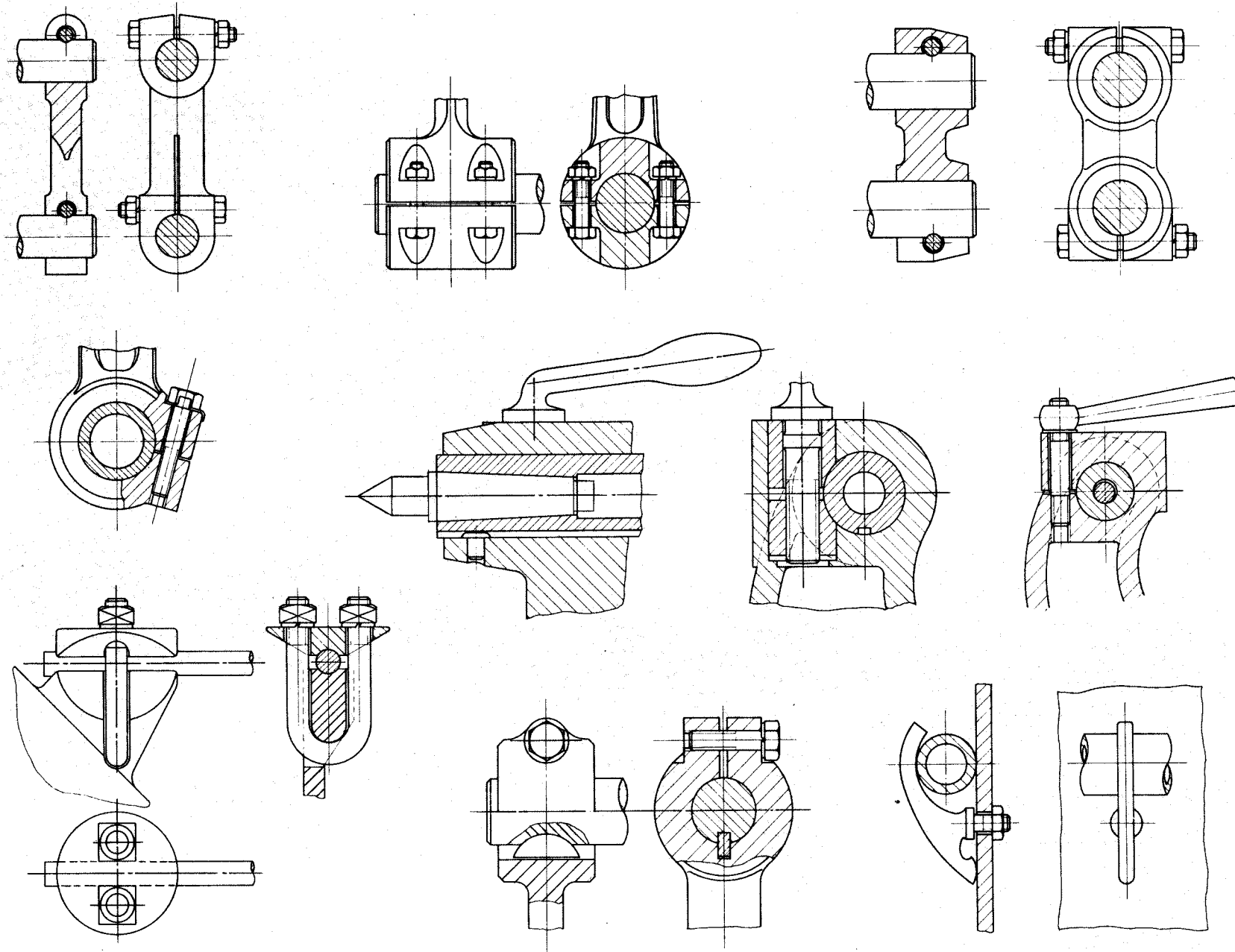

JUNTAS - UNIÕES

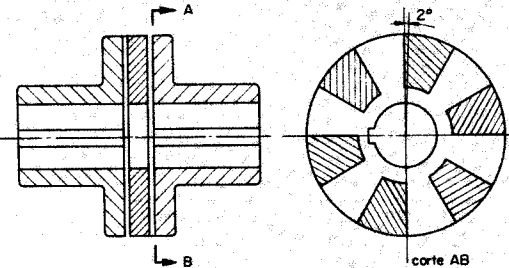
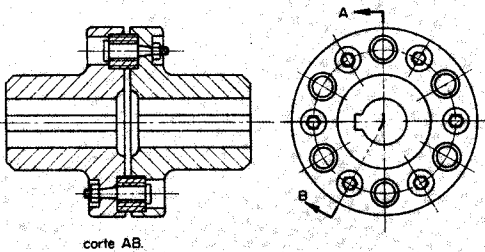
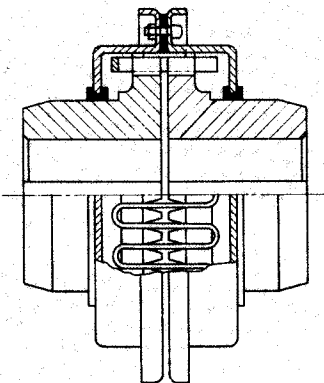
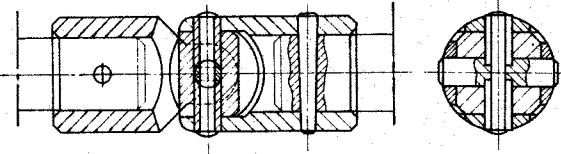
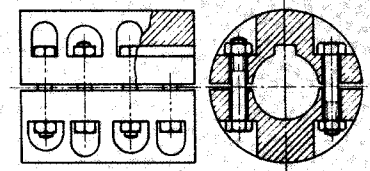
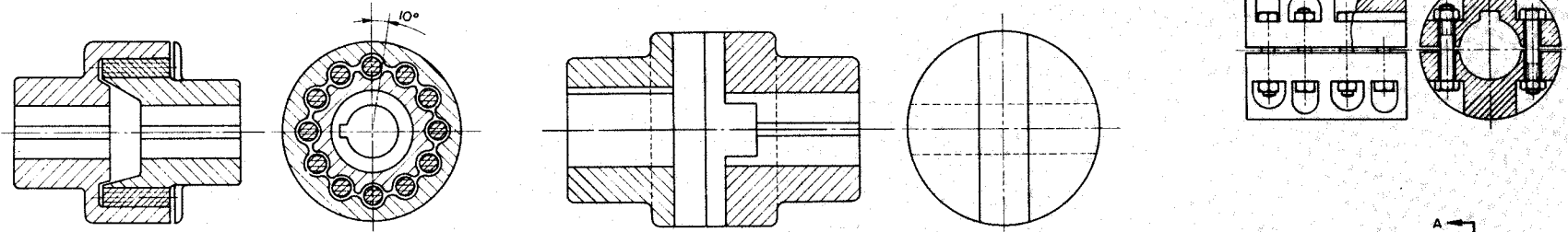
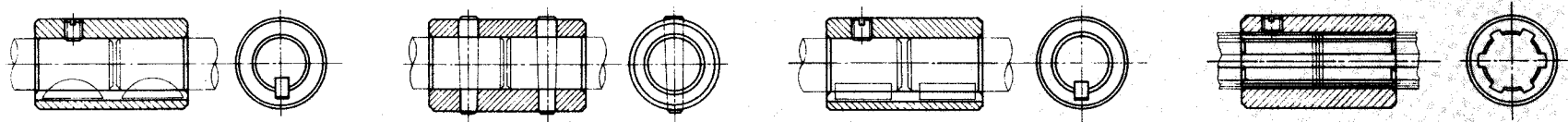

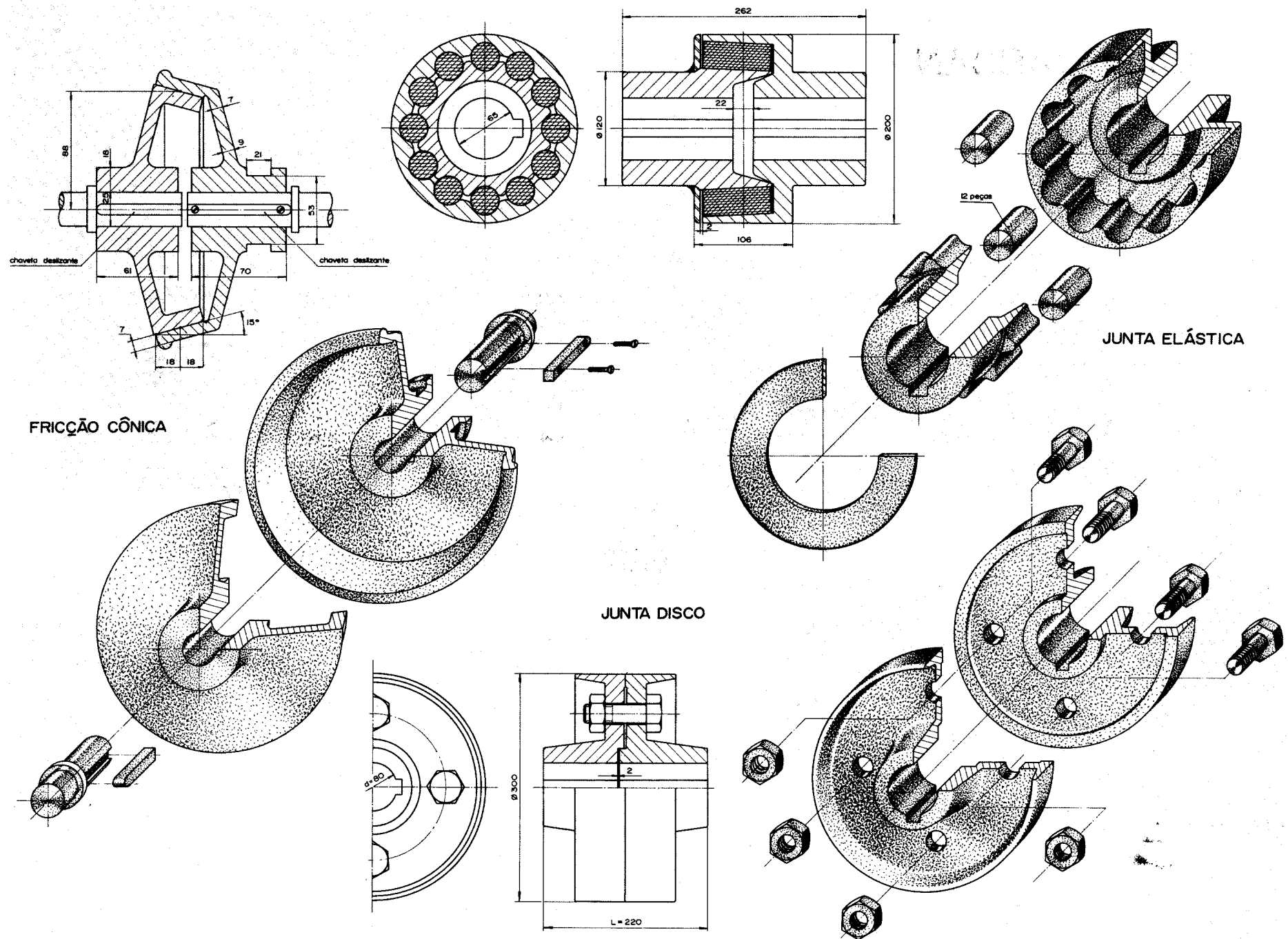

EIXO CARDAN

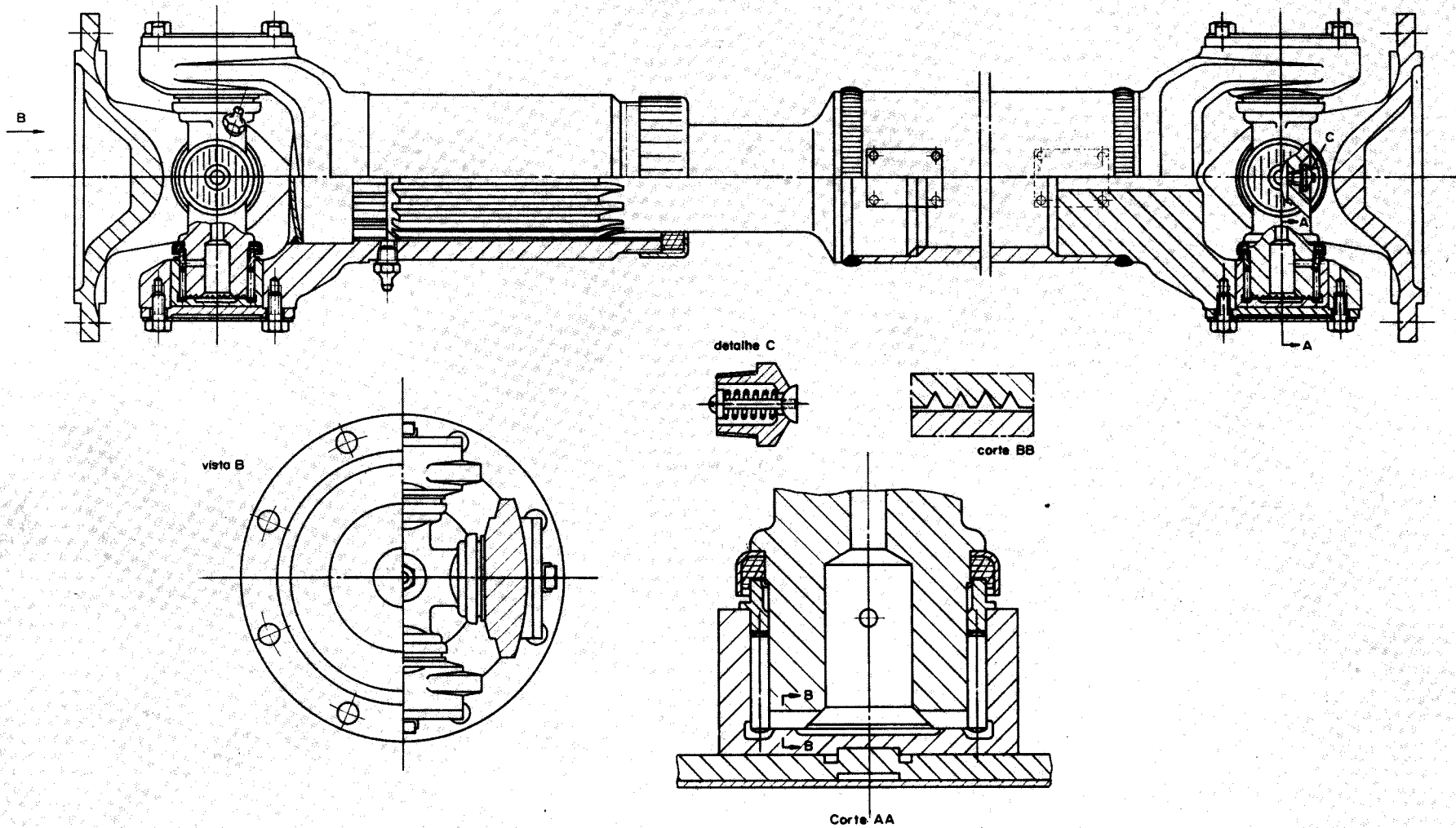

FLANGES

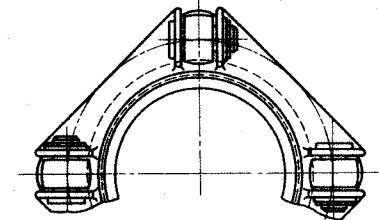
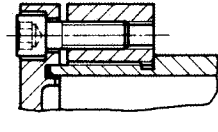
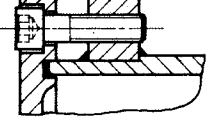
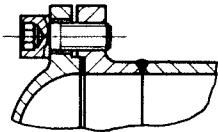
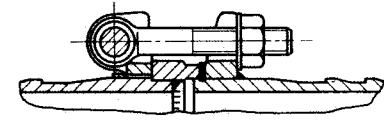
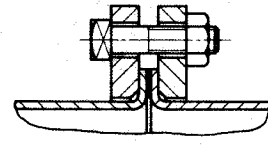
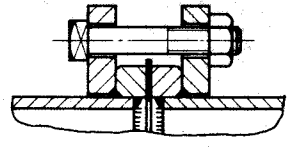
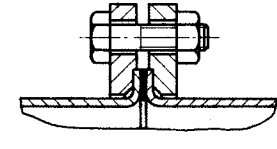
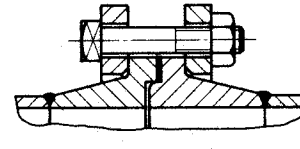
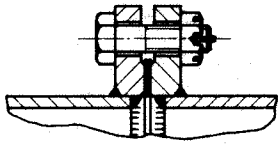
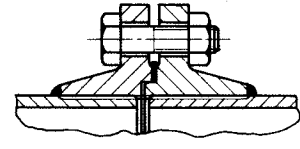
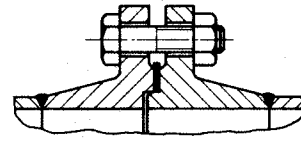
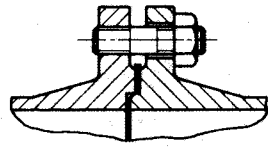
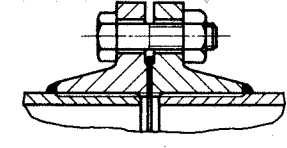
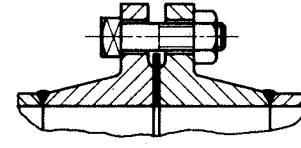
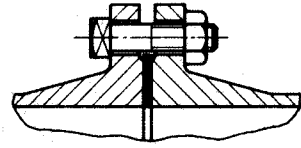
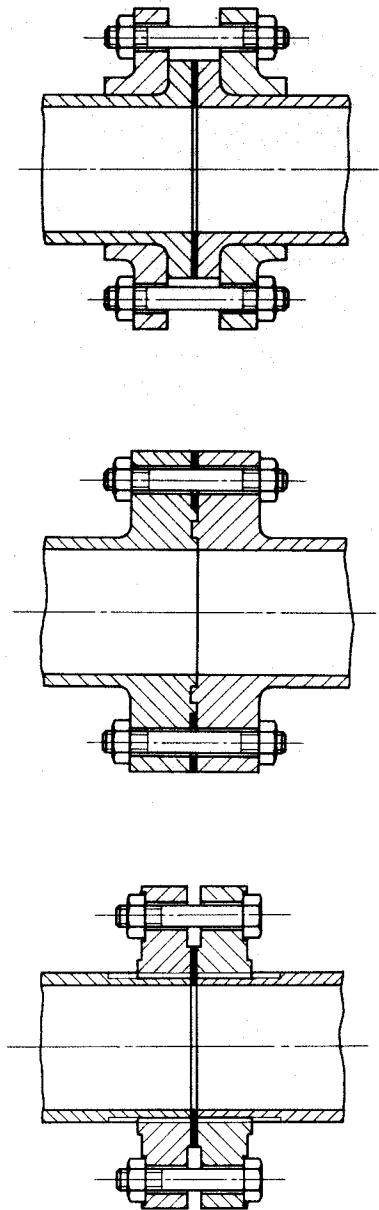

ENGRAXADEIRAS E MARCADORES DE ÓLEO

ENGRAXADEIRAS TECALEMIT

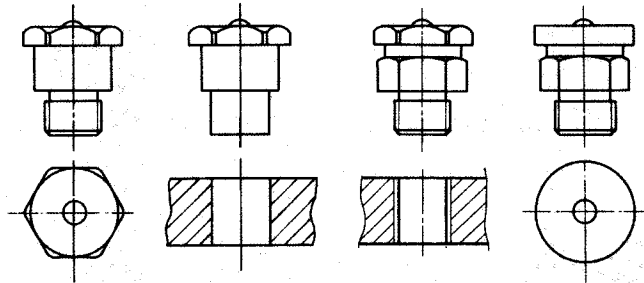

ENGRAXADEIRAS LUB

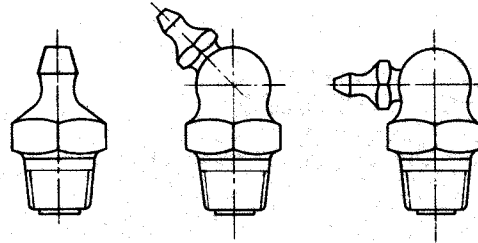

ENGRAXADEIRA STAUFFER

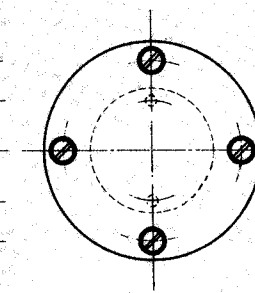
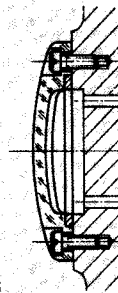
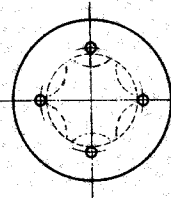
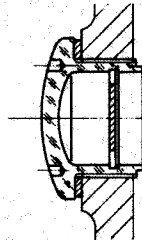
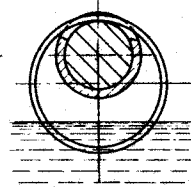
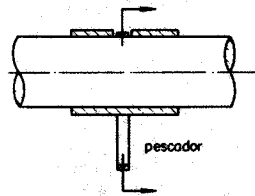
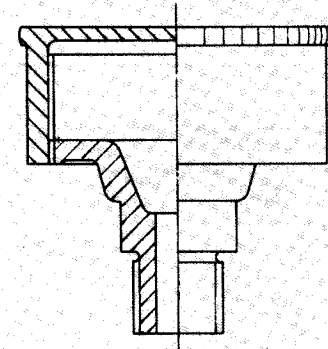

VISORES

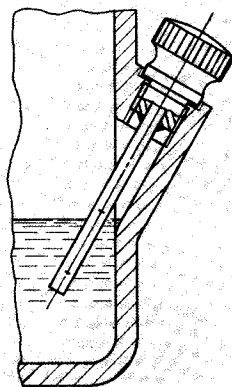
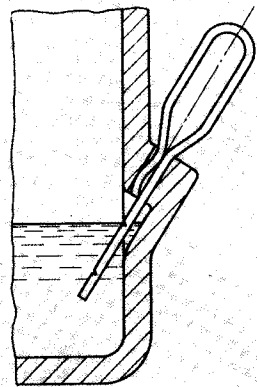

VARETAS

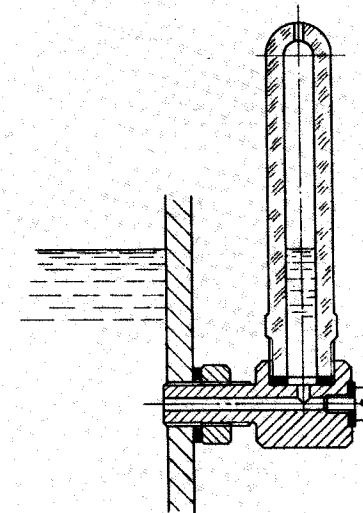
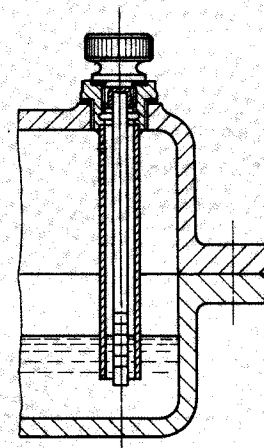

NÍVEL TUBULAR

MOLAS

MOLAS HELICOIDAIS

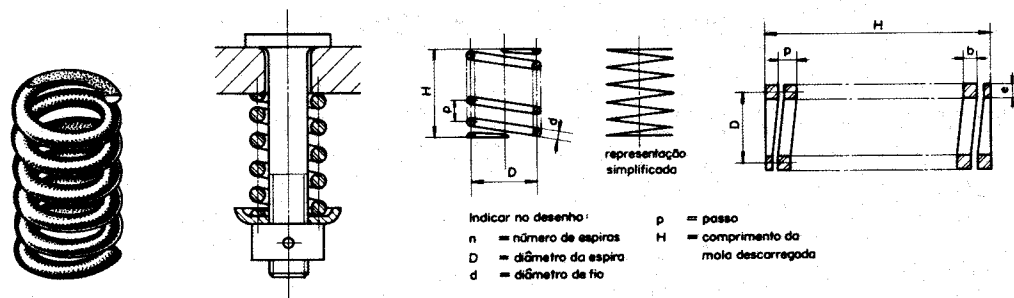

Indicar no desenho:
 n = número de espiras
 D = diâmetro da espira
 d = diâmetro de fio
 p = passo
 H = comprimento da mola descarregada

representação simplificada

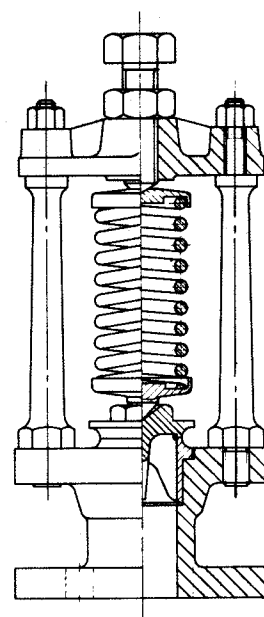
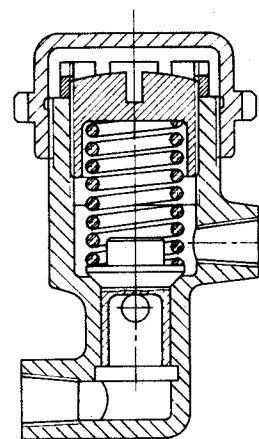
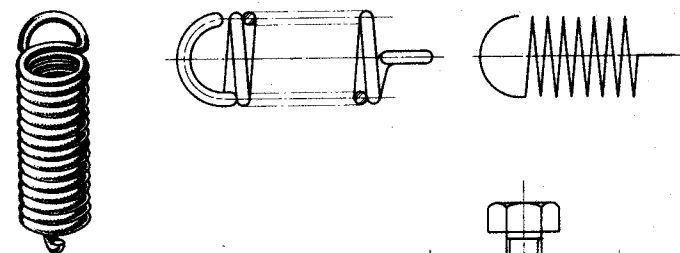

Indicar no desenho:
 n = número de voltas quando descarregada
 $b \times e$ = seção de fita
 d_i = diâmetro do eixo
 d_e = diâmetro externo

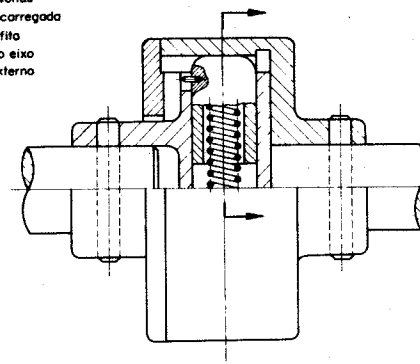

MOLA CÔNICA

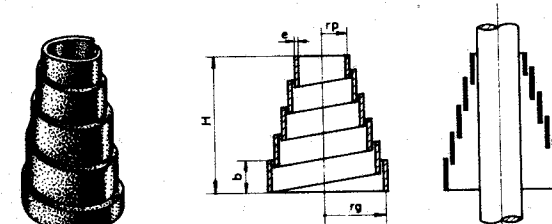

Indicar no desenho:
 $b \times e$ = seção de fita
 H = comprimento da mola descarregada
 r_p = raio pequeno
 r_g = raio grande
 n = número de espiras

MOLA EM ESPIRAL

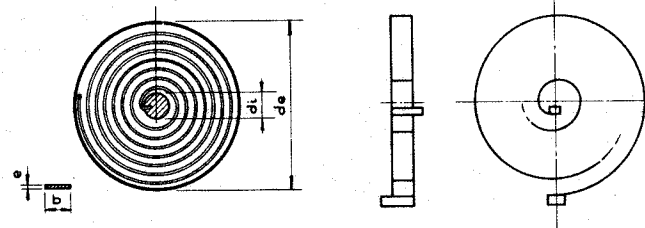
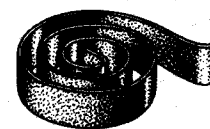

MOLA BALESTRA

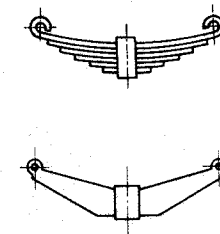
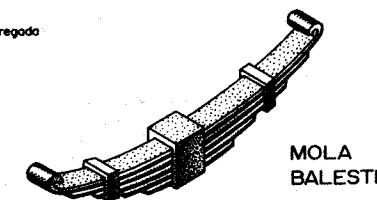

TOLERÂNCIAS E AJUSTES

- 1 - Dimensão efetiva: valor obtido medindo a peça.
- 2 - Dimensão máxima $D_{m\acute{a}x}$: valor máximo admissível para a dimensão efetiva.
- 3 - Dimensão mínima $D_{m\grave{m}n}$: valor mínimo admissível para a dimensão efetiva.
- 4 - Tolerância t : variação permissível da dimensão da peça, dada pela diferença entre a dimensão máxima e a mínima.

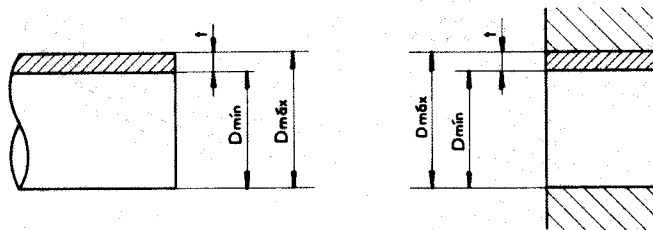

$$t = D_{m\acute{a}x} - D_{m\grave{m}n}$$

- 5 - Linha zero: linha que nos desenhos fixa a dimensão nominal e serve de origem aos afastamentos.
- 6 - Afastamento inferior: diferença entre a dimensão mínima e a nominal. Símbolos: A_i para furo, a_i para eixo.
- 7 - Afastamento superior: diferença entre a dimensão máxima e a nominal. Símbolos: A_s para furo, a_s para eixo.

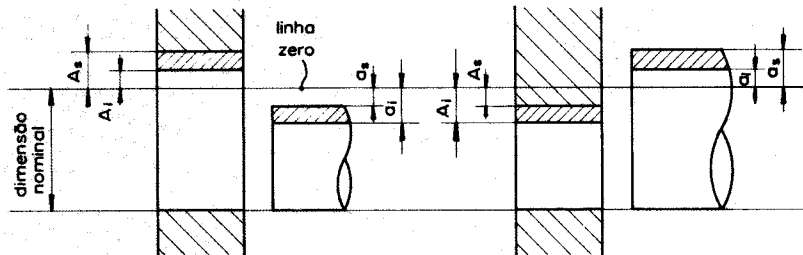

- 8 - Ajuste: comportamento de um eixo num furo, ambos da mesma dimensão nominal, caracterizado pela folga ou interferência apresentada.

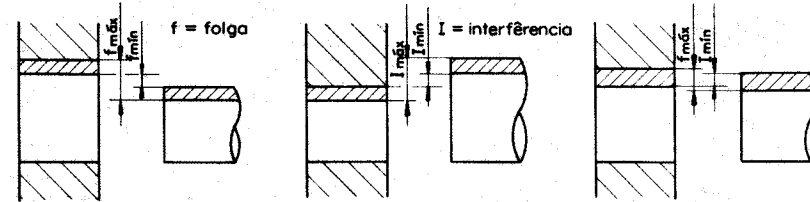

ajuste com folga

ajuste com interferência

ajuste incerto

- 9 - Eixo: termo convencionalmente aplicado para fins de tolerâncias e ajustes, como sendo qualquer parte de uma peça cuja superfície externa é destinada a alojar-se na superfície interna de outra.
- 10 - Eixo base: é o eixo em que o afastamento superior é preestabelecido como sendo igual a zero.
- 11 - Furo: termo convencionalmente aplicado para fins de tolerâncias e ajustes, como sendo todo espaço delimitado por superfície interna de uma peça e destinado a alojar o eixo.
- 12 - Furo base: é o furo em que o afastamento inferior é preestabelecido como sendo igual a zero.
- 13 - Sistema de ajuste: conjunto de princípios, regras, fórmulas e tabelas que permite a escolha racional de tolerâncias no acoplamento eixo-furo, para se obter economicamente uma condição preestabelecida.
- 14 - Sistema de tolerância: conjunto de princípios, regras, fórmulas e tabelas que permite a escolha racional de tolerâncias para a produção econômica das peças mecânicas intercambiáveis. (v. tabelas do "Prontuário do Projetista de Máquinas".)

15 - A escolha das tolerâncias é feita por meio de fórmulas ou por meio de tabelas.

16 - A qualidade de trabalho (campo de tolerância) é designada por números: 01, 0, 1, 2, ..., 15, 16 na ordem decrescente de qualidade.

17 - A posição dos campos de tolerância em relação à dimensão nominal é designada por letras. As letras maiúsculas são reservadas para os furos e as minúsculas para os eixos.

furos: A, B, C, ..., Y, Z eixos: a, b, c, ..., y, z

18 - A indicação da tolerância é feita por meio de símbolos. Cada símbolo é formado acrescentando à letra do campo o número indicativo da qualidade.

Exemplo: Eixo f8 e furo H8.

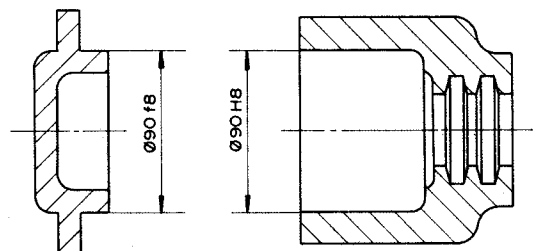

19 - A indicação da tolerância também pode ser feita colocando-se diretamente sobre o desenho os valores obtidos em tabelas.

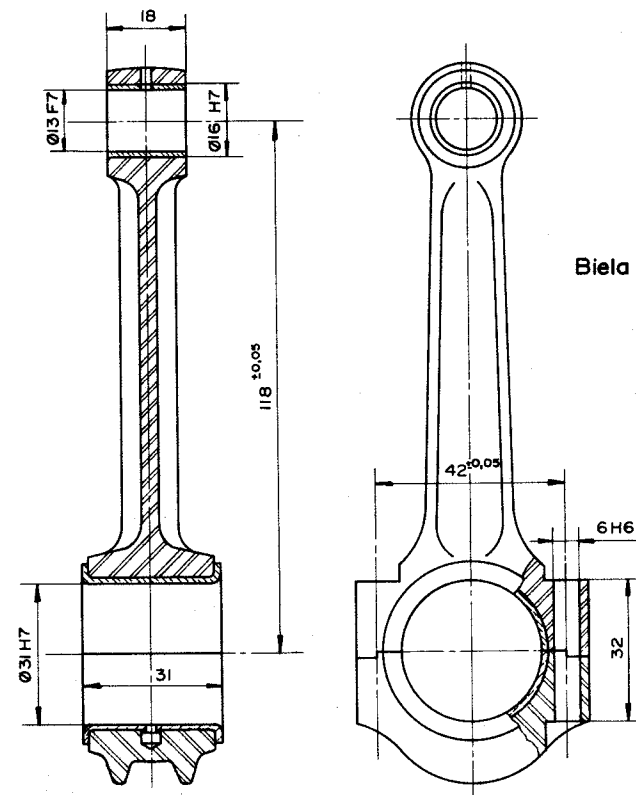
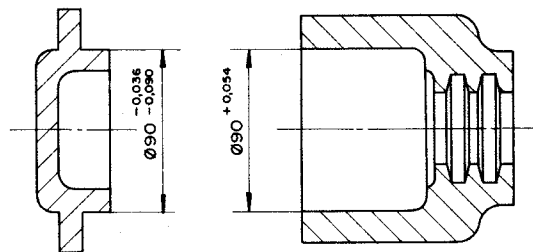

Biela

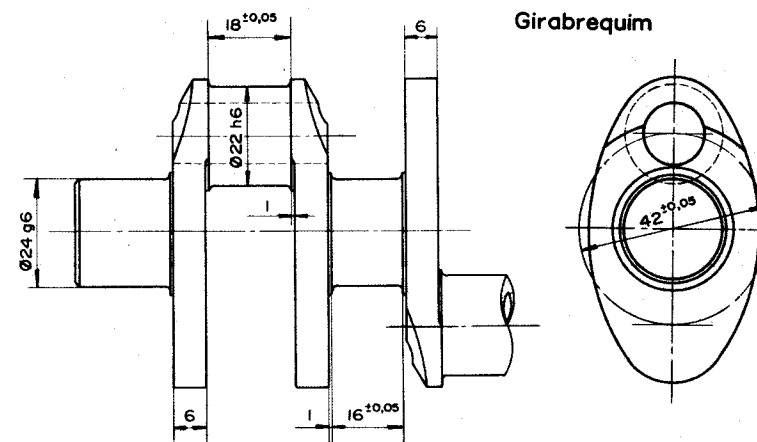

Girabrequim

TIPOS DE ROLAMENTOS

ROLAMENTOS FIXOS DE UMA CARREIRA DE ESFERAS

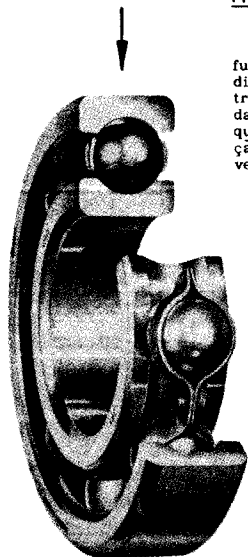

O rolamento fixo de uma carreira de esferas tem pistas profundas, sem orifício para a entrada das esferas. Graças a profundidade das pistas, ao tamanho das esferas e ao íntimo contacto entre as esferas e as pistas, possui esse rolamento grande capacidade de carga, inclusive no sentido axial. É por isso muito adequado para resistir a cargas de todas as direções. Sua construção lhe permite suportar consideráveis cargas axiais, mesmo a velocidades muito elevadas.

ROLAMENTOS AUTOCOMPENSADORES DE ESFERAS

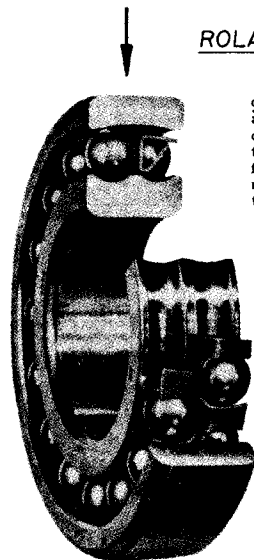

O rolamento autocompensador de esferas tem duas carreiras de esferas e uma pista esférica comum no anel externo. Graças à esfericidade da pista, o rolamento é autocompensador, o que o torna insensível a ligeiros desalinhamentos do eixo provenientes de montagem defeituosa, esforços sobre o eixo, desnível das fundações, etc. Pelo mesmo motivo, o rolamento não pode ocasionar flexões no eixo, o que é de grande importância quando se trata de aplicações em que se requer alta velocidade e exatidão.

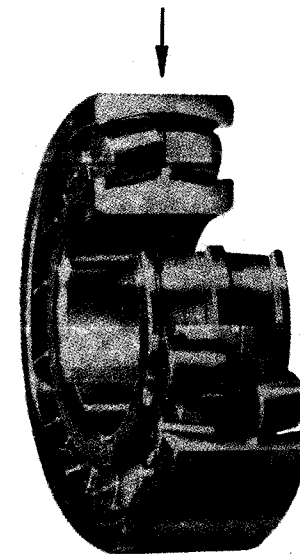

ROLAMENTOS AUTOCOMPENSADORES DE ROLOS

O rolamento autocompensador de rolos tem duas carreiras de rolos e uma pista esférica comum no anel externo, característica à qual deve sua propriedade de alinhamento automático. O número e o tamanho de seus rolos e a exatidão com que estes são guiados, conferem a esse rolamento uma capacidade de carga muito grande. O de tipo longo também pode suportar cargas axiais consideráveis, provenientes de qualquer direção.

ROLAMENTOS DE ROLOS CILÍNDRICOS

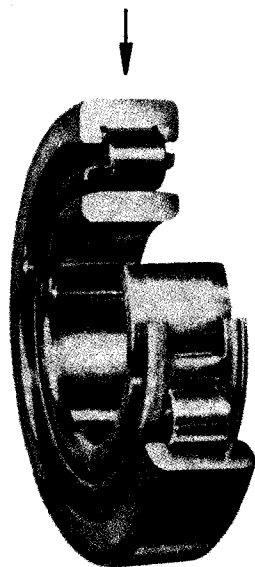

Os rolos do rolamento cilíndrico são guiados por rebordos em um dos anéis. O outro anel geralmente não tem rebordos. Esta execução apresenta a vantagem de permitir que o eixo se desloque axialmente dentro de certos limites, em relação à caixa. Os rolamentos com rebordos nos dois anéis podem fixar axialmente o eixo, sempre que as forças sejam muito reduzidas. A desmontagem é muito fácil, mesmo que ambos os anéis estejam montados com ajuste forte. Este rolamento é adequado para cargas relativamente grandes e pode também suportar altas velocidades.

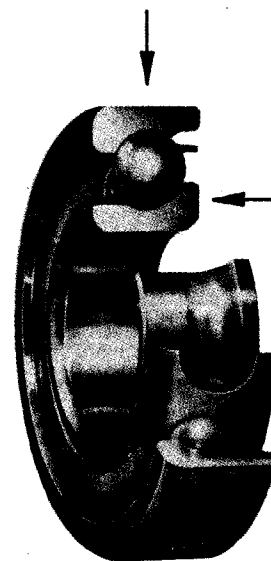

ROLAMENTOS DE CONTACTO ANGULAR

O rolamento de contacto angular de uma carreira de esferas tem as pistas dispostas de forma que a pressão exercida pelas esferas está dirigida em ângulo agudo com respeito ao eixo. Em consequência desta disposição, o rolamento é especialmente apropriado para resistir a uma grande carga axial, devendo-se montá-lo contraposto a outro rolamento que possa receber a carga axial existente em sentido contrário. Este rolamento não é desarmável.

**ROLAMENTOS DE CONTACTO ANGULAR
DE 2 CARREIRAS DE ESFERAS**

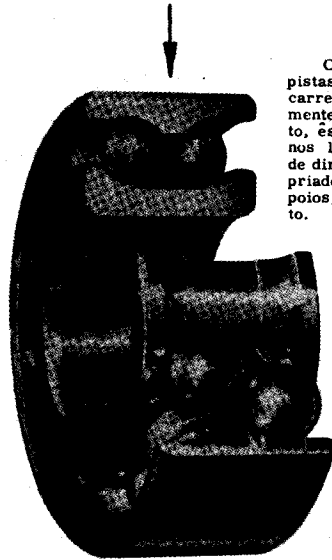

O rolamento de contacto angular de duas carreiras tem as pistas de maneira que as linhas de pressão formadas pelas duas carreiras de esferas se dirigem a dois pontos do eixo relativamente distante entre si. Ao contrário de outros tipos de rolamento, este tem carga prévia, que lhe permite reduzir, entre pequenos limites, os movimentos axiais do eixo, mesmo sob cargas de direção variável. Por sua construção, este rolamento é apropriado para órgãos giratórios de máquinas que requerem dois apoios, porém nos quais se dispõe de espaço para um só rolamento.

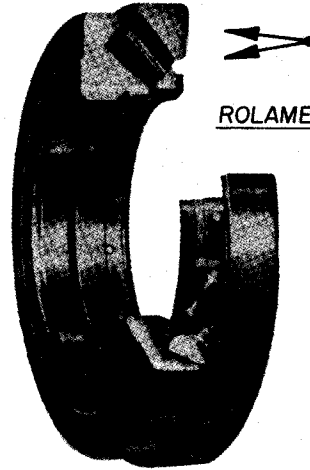

ROLAMENTOS AXIAIS AUTOCOMPENSADORES DE ROLOS

O rolamento axial autocompensador de rolos tem uma carreira de rolos em posição oblíqua, os quais, guiados por um ressalto da placa móvel, giram sobre a superfície esférica da placa fixa. Em consequência, o rolamento possui capacidade de carga muito grande e alinhamento automático perfeito. Graças à execução especial da superfície de apoio dos rolos no ressalto de guia, os rolos giram separados do ressalto por uma fina camada de óleo. O rolamento pode, por isso, girar a grande velocidade, mesmo suportando elevada carga. Contrariamente aos outros rolamentos axiais, este pode, também, resistir a cargas radiais.

**ROLAMENTOS AXIAIS DE ESFERAS
ESCORA SIMPLES**

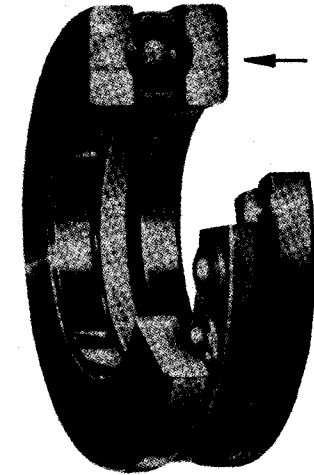

O rolamento axial de esferas de escora simples consta de uma carreira de esferas entre duas placas, uma das quais, a placa móvel, é de assento plano, enquanto que a outra, a placa fixa, pode ter assento plano ou esférico. Neste último caso, o rolamento se apoia em uma contraplaca. Os rolamentos com assento plano no deveriam, sem dúvida, ser preferidos para a maioria das aplicações, porém, os de assento esférico são muito úteis em certos casos, para compensar pequenas inexactidões de fabricação das caixas. O rolamento destina-se a suportar carga axial em uma direção.

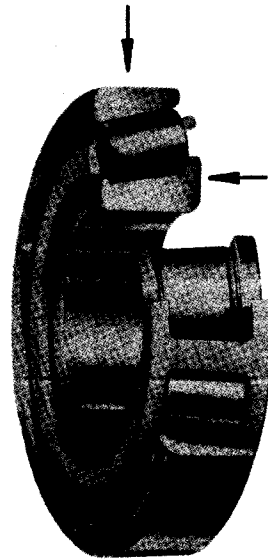

**ROLAMENTOS DE ROLOS CÔNICOS
DE UMA CARREIRA DE ESFERAS**

O rolamento de rolos cônicos, graças à posição oblíqua dos rolos e da pista, é especialmente adequado para resistir a cargas radiais e axiais. Para os casos em que a carga axial é muito importante, há uma série de rolamentos cujo ângulo é muito aberto. Este rolamento deve ser montado contraposto a outro capaz de suportar os esforços axiais em sentido contrário. O rolamento é desarmável; o anel interno com seus rolos e o anel externo armam-se cada um separadamente.

ROLAMENTOS DE AGULHAS

Os rolamentos de agulhas, indicados para suportar esforços radiais intensos, são de pequena espessura, possibilitando, assim, o emprego de assentos mais leves e de dimensões reduzidas; apresentam alta rigidez, o que permite que suportem maiores cargas com muito menor desgaste; funcionam silenciosamente, mesmo quando são submetidos a regimes de altas rotações.

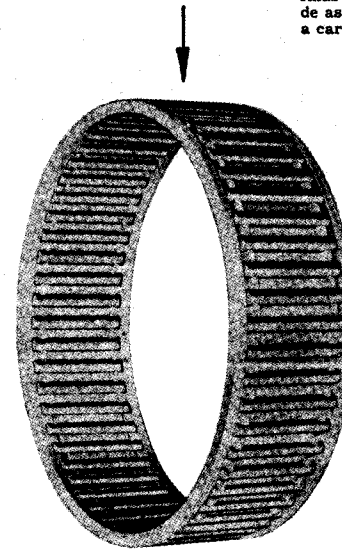

**ROLAMENTOS AXIAIS DE ESFERAS
ESCORA DUPLA**

O rolamento axial de esferas de escora dupla tem duas carreiras de esferas, uma para cada direção de carga, e três placas fixas são iguais às do rolamento de escora simples, podendo ser de assento plano ou esférico. O rolamento destina-se a resistir a cargas axiais de direção variável.

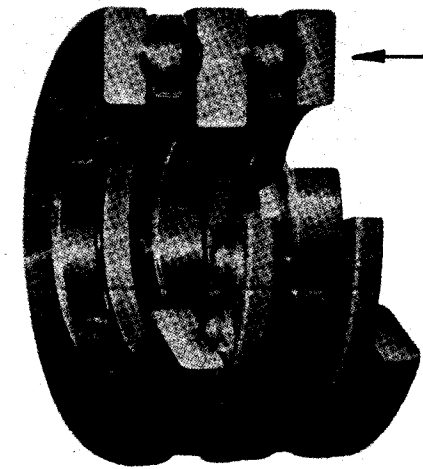

FIXAÇÃO E VEDAÇÃO DE ROLAMENTOS

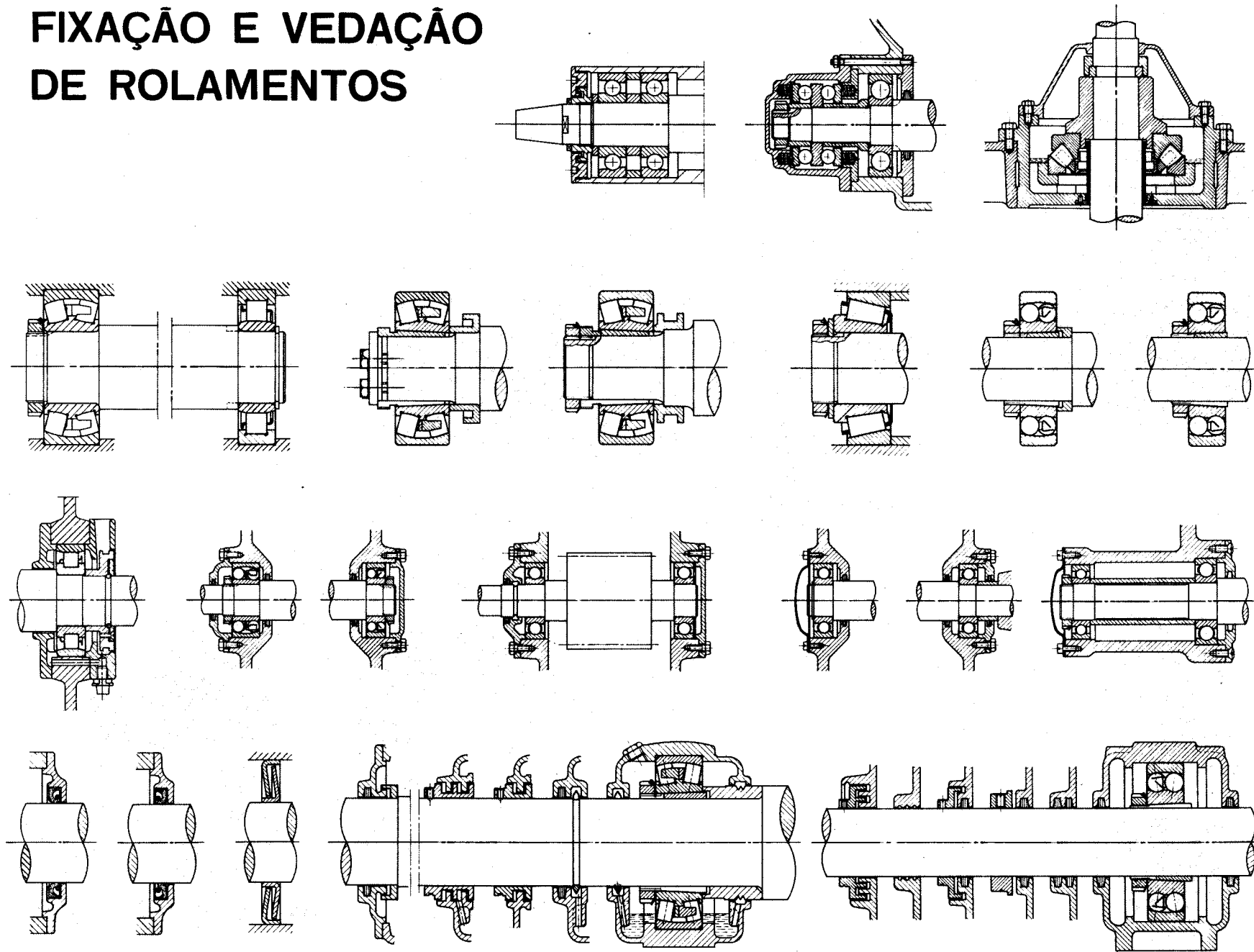

APLICAÇÃO DE ROLAMENTOS

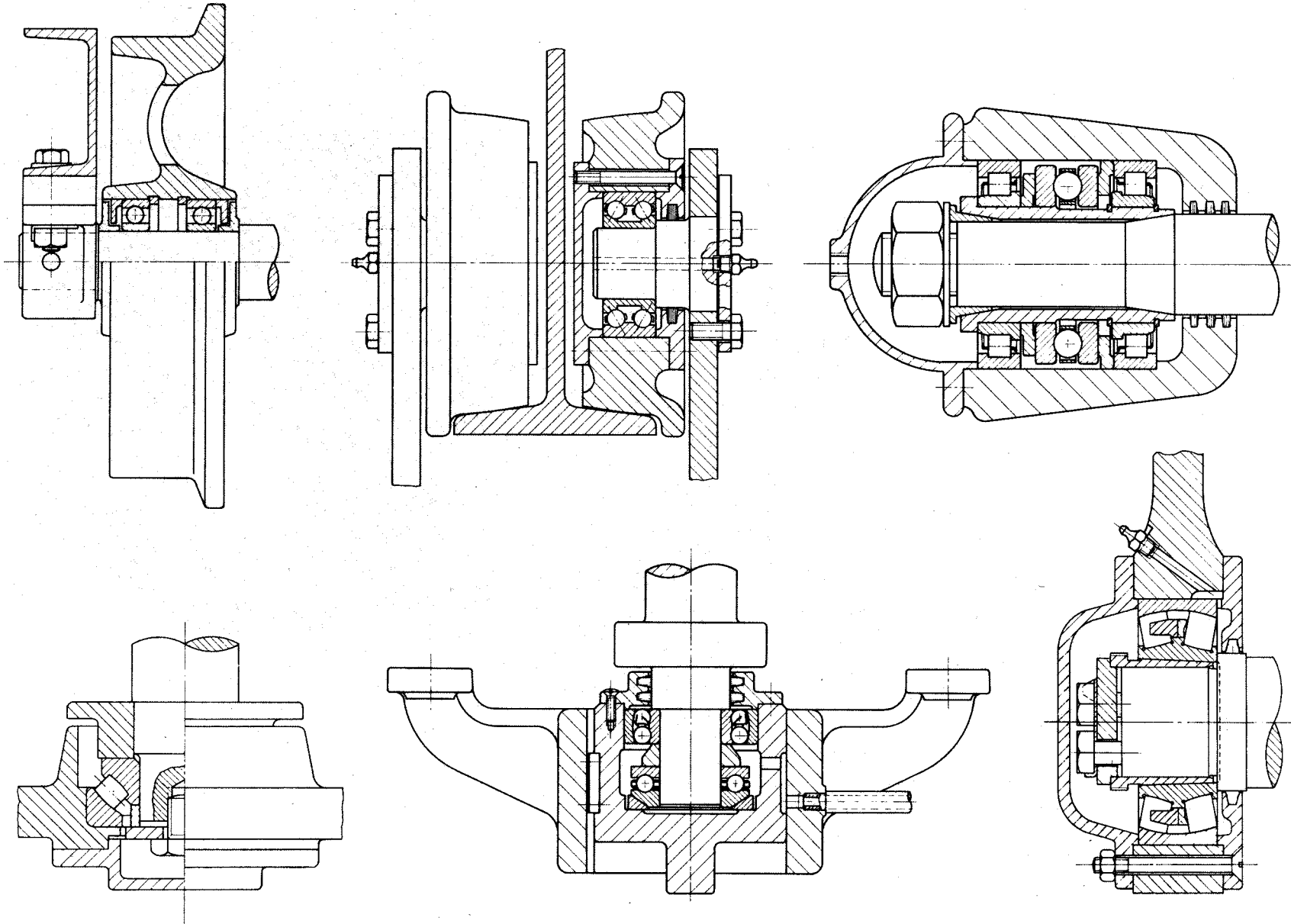

ENGRENAGENS CILÍNDRICAS DE DENTES RETOS

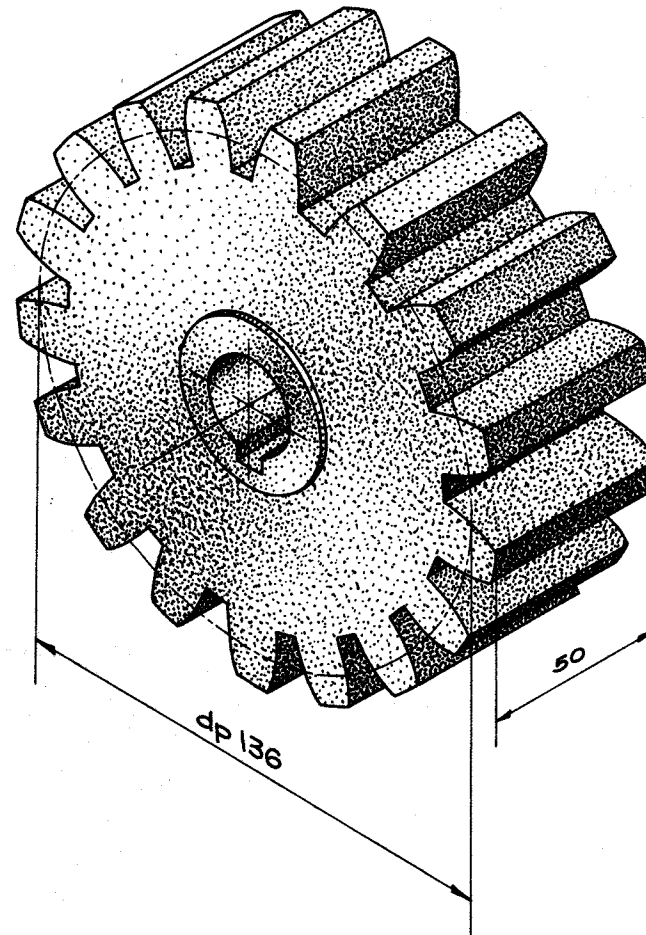
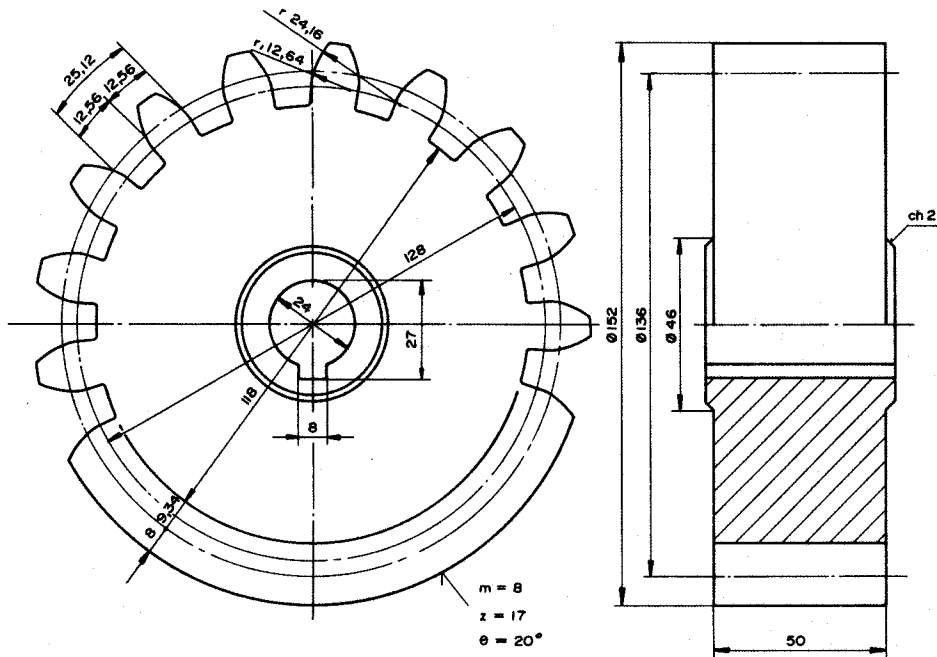

DADOS

módulo $m = 8$ número de dentes $z = 17$

CÁLCULOS PARA O DESENHO

diâmetro primitivo $d_p = mz = 136$

passo $P = m\pi = 25,12$

cabeça do dente $a = m = 8$

pe do dente $b = 1,167m = 9,336 \approx 9,34$

espessura $s = \text{vão } v = P/2 = 12,56$

ângulo de pressão $\theta = 14^\circ 30' - 15^\circ - 20^\circ - 22^\circ 30' \therefore \theta = 20^\circ$

diâmetro de base $d_b = d_p \cos \theta = 128$

r e r_1 : ver pág. 6-105 $r = fm = 3,02 \cdot 8 = 24,16$

$r_1 = f'm = 1,58 \cdot 8 = 12,64$

comprimento do dente $l = (6 \div 20)m = 50$

CÁLCULOS

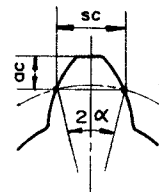
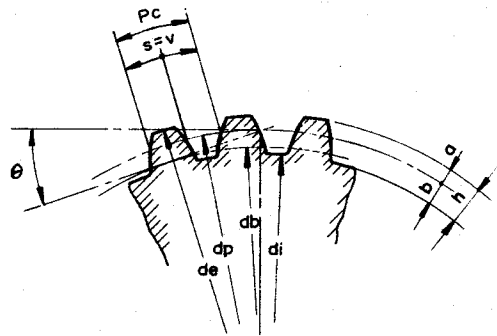
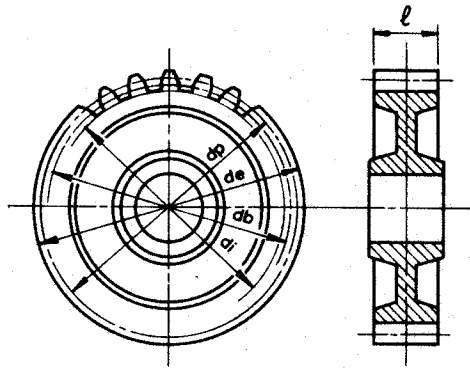

DESCRIÇÃO	ENGRENAGEM
número de dentes	$z = 17$
módulo	$m = 8$
diâmetro primitivo	$d_p = m z = 136$
passo	$P = m\pi = 25,12$
espessura circular e vão	$s = v = P/2 = 12,56$
espessura cordal	$s_c = m z \text{ sen } \alpha = 12,56$
diâmetro externo	$d_e = m (z + 2) = 152$
diâmetro interno	$d_i = m (z - 2,334) = 117,32$
ângulo de pressão	$\theta = 20^\circ$
diâmetro do círculo de base	$d_b = d_p \cos \theta = 128$
altura da cabeça do dente	$a = m = 8$
altura da cabeça do dente (cordal)	$a_c = m \left[1 + \frac{z}{2} (1 - \cos \alpha) \right] = 8,27$
altura do pé do dente	$b = 1,167 m = 9,34$
altura do dente	$h = a + b = 17,34$
folga no pé do dente	$e = 0,167 m = 1,34$
comprimento do dente	$l = (6 + 20) m = 50$
ângulo do dente	$\alpha = 90/z = 5^\circ 18'$

ENGRENAGENS CILÍNDRICAS DE DENTES RETOS SISTEMA PITCH

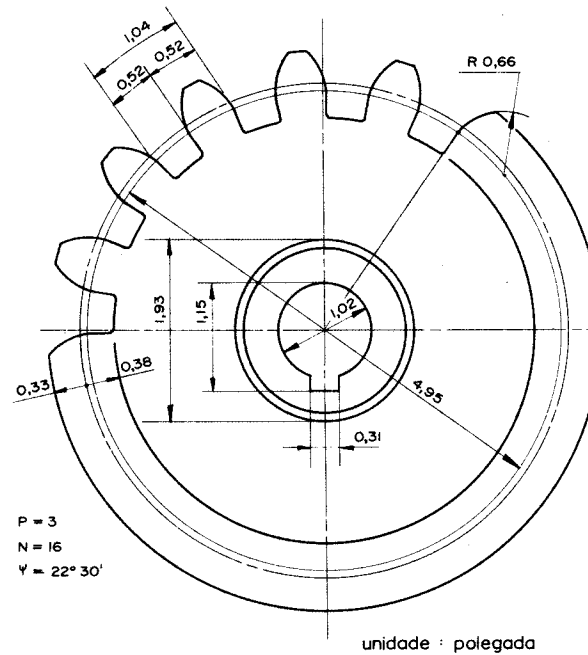
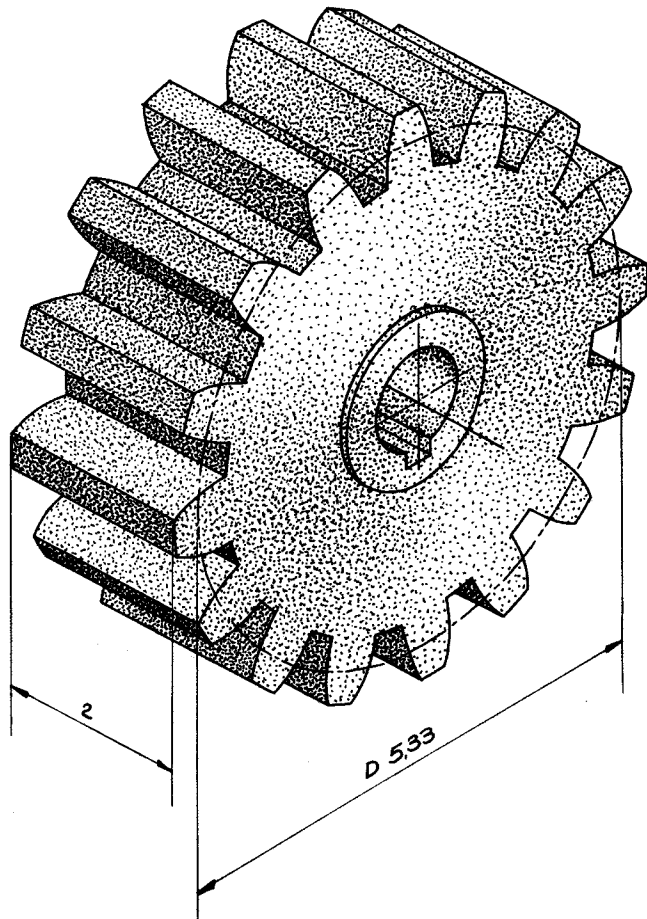

P = 3
N = 16
 $\gamma = 22^\circ 30'$

unidade : polegada

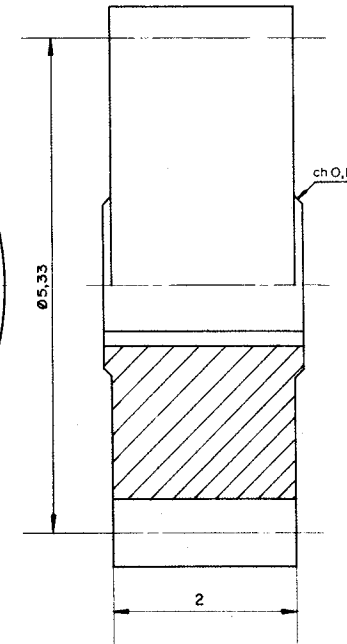

DADOS

Diametral Pitch P = 3 número de dentes N = 16

CÁLCULOS PARA O DESENHO

diâmetro primitivo $D = N/P = 5,33$

passo circunferencial (Circular Pitch) $P' = \pi/P = 1,04$

cabeça do dente $A = 1/P = 0,33$

pé do dente $B = 1,1571/P = 0,38$

espessura do dente $T_c = P'/2 = 0,52$

ângulo de pressão $\gamma = 22^\circ 30'$

diâmetro de base $D_b = D \cos \gamma = 4,95$

perfil do dente $R = D/8 = 0,66$

comprimento do dente $L = (6 \div 20)/P = 2$

CÁLCULOS

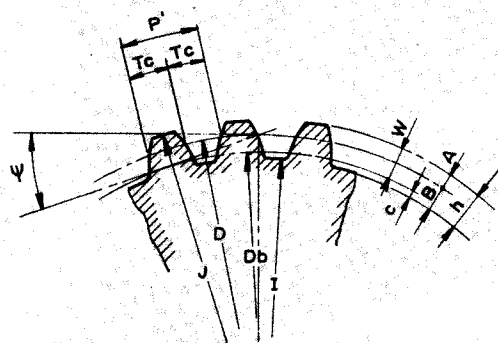
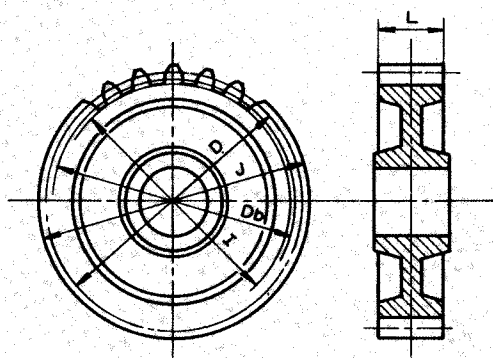

DIAMETRAL PITCH é o número de dentes por polegada de diâmetro primitivo e corresponde ao inverso do módulo : $P = 25,4/m$ [1/pol.]

CIRCULAR PITCH é o passo em polegada

DESCRIÇÃO	ENGRENAGEM
número de dentes	$N = 16$
Diametral Pitch	$P = 3$
diâmetro primitivo	$D = N/P = 5,33$
passo circunf. (Circular Pitch)	$P' = \pi/P = 1,04$
espessura do dente	$T_c = P'/2 = 0,52$
diâmetro externo	$J = (N+2)/P = 6,0$
diâmetro interno	$I = (N-2,3142)/P = 4,56$
ângulo de pressão	$\psi = 22^\circ 30'$
diâmetro do círculo de base	$Db = D \cos \psi = 4,95$
altura da cabeça do dente	$A = 1/P = 0,33$
altura do pé do dente	$B = 1,1571/P = 0,38$
altura do dente	$h = A + B = 0,71$
altura teórica do dente	$W = 2/P = 0,66$
folga no pé do dente	$c = 0,1571/P = 0,05$
comprimento do dente	$L = (6-20)/P = 2$

(polegada)

ENGRENAGEM E CREMALHEIRA

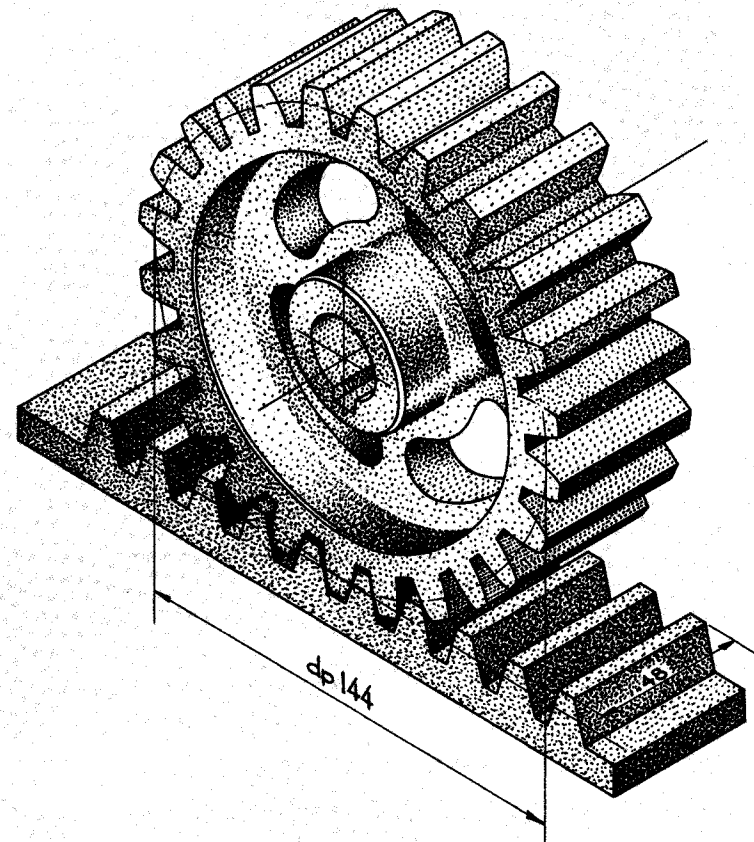
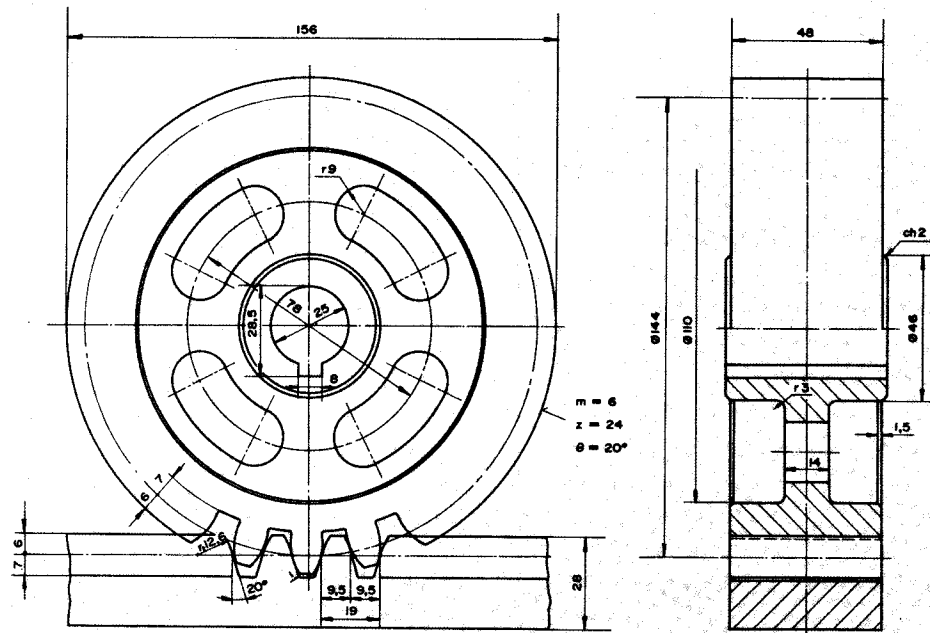

DADOS

$m = 6$ $z = 24$ ângulo de pressão $\theta = 20^\circ$

CÁLCULOS PARA O DESENHO

diâmetro primitivo $dp = mz = 144$

cabeça do dente $a = m = 6$

pé do dente $b = 1,67m = 7$

comprimento do dente $l = (6 \div 20)m = 48$

$r_1 = 2,1m = 12,6$

$r_2 = \frac{m}{6} = 1$

CÁLCULOS

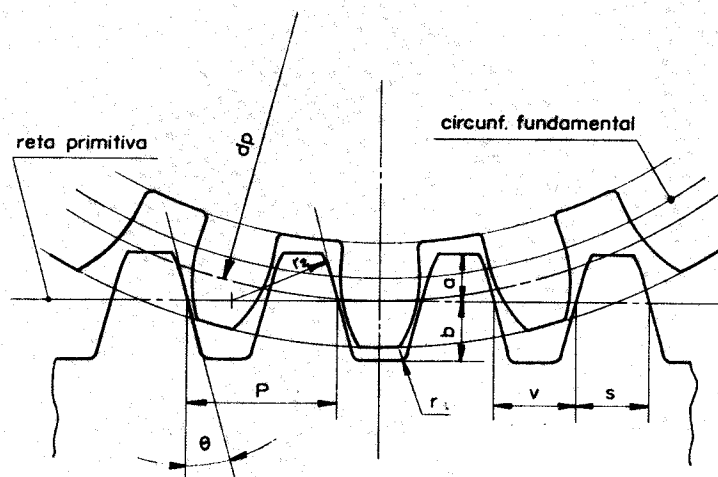

E19
= 1

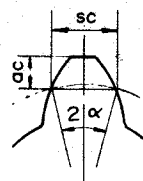

$r_2 = 2,1m$

DESCRIÇÃO	ENGRENAGEM
número de dentes	$z = 24$
módulo	$m = 6$
diâmetro primitivo	$d_p = m z = 144$
passo	$P = m\pi = 18,84$
espessura circular e vão	$s = v = P/2 = 9,42$
espessura cordal	$sc = m z \sin\alpha = 9,417$
diâmetro externo	$d_e = m(z + 2) = 156$
diâmetro interno	$d_i = m(z - 2,334) = 129,99$
ângulo de pressão	$\theta = 20^\circ$
diâmetro do círculo de base	$d_b = d_p \cos\theta = 135,4$
altura da cabeça do dente	$a = m = 6$
altura da cabeça do dente (cordal)	$ac = m \left[1 + \frac{z}{2} (1 - \cos\alpha) \right] = 6,154$
altura do pé do dente	$b = 1,167 m = 7$
altura do dente	$h = a + b = 13$
folga no pé do dente	$e = 0,167 m = 1$
comprimento do dente	$l = (6 + 20) m = 48$
ângulo do dente	$\alpha = 90/z = 3^\circ 45'$

ENGRENAGENS CILÍNDRICAS DE DENTES RETOS

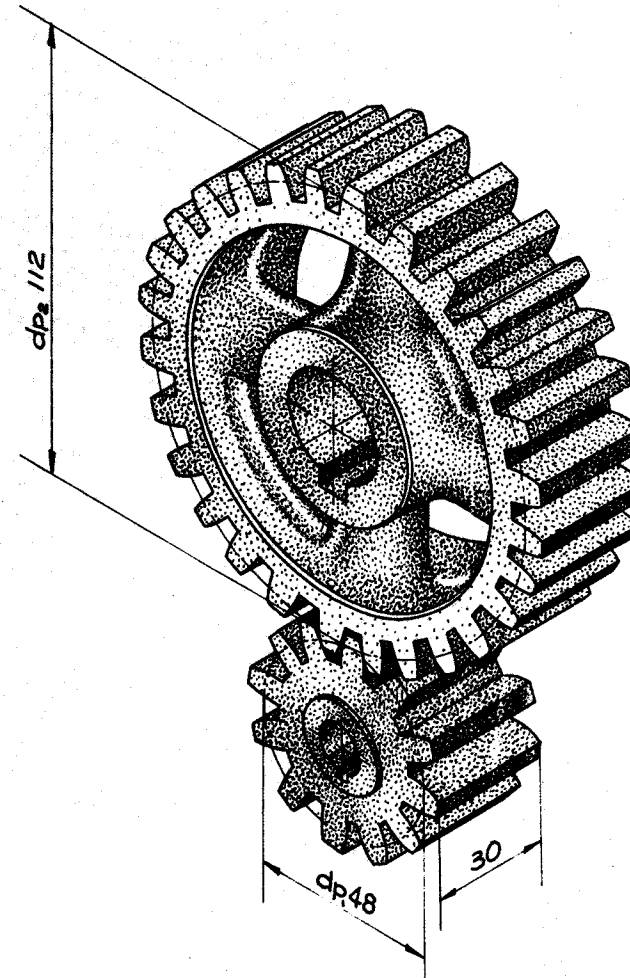
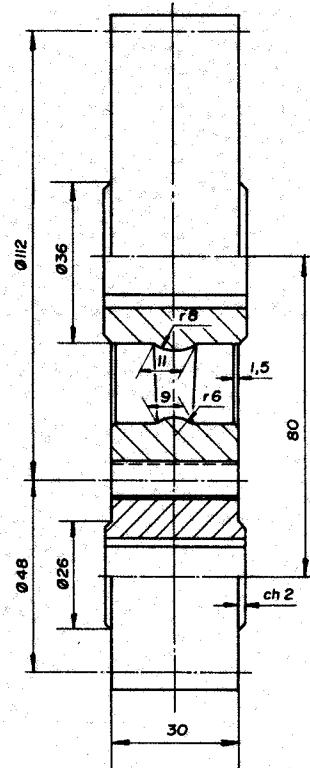
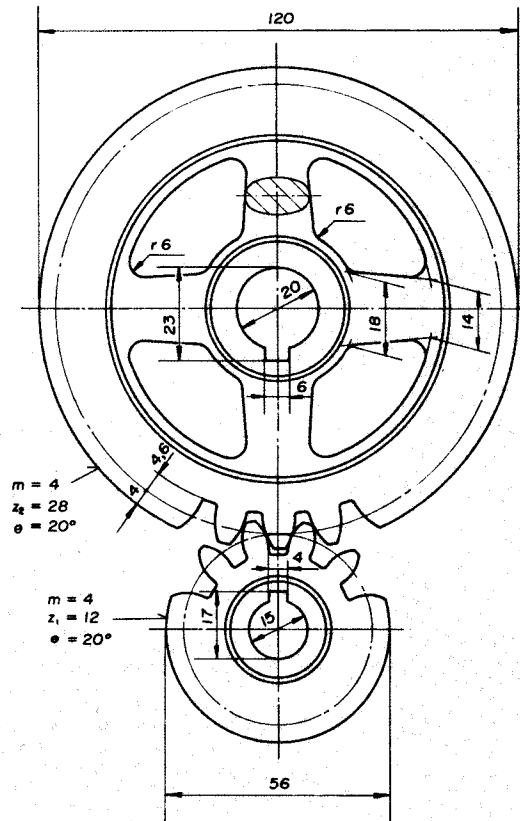

DADOS

módulo $m = 4$ número de dentes do pinhão $z_1 = 12$ da coroa $z_2 = 28$ $\phi = 20^\circ$

CÁLCULOS PARA O DESENHO

diâm. primitivo do pinhão $dp_1 = mz_1 = 48$

diâm. primitivo da coroa $dp_2 = mz_2 = 112$

cabeça do dente $a = m = 4$

pé do dente $b = 1,167m = 4,668$

comprimento do dente $l = (6 - 20) = 30$

CÁLCULOS

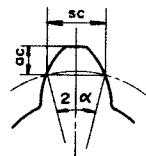
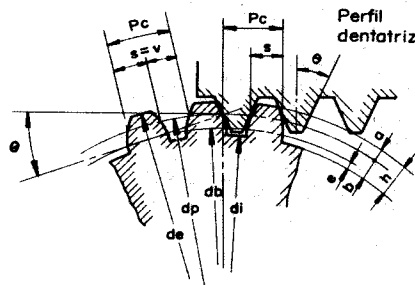
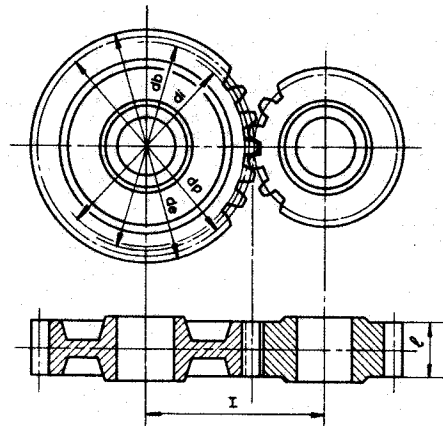

DESCRIÇÃO	PINHÃO	COROA
número de dentes	$z_1 = 12$	$z_2 = 28$
módulo	$m = 4$	
diâmetro primitivo	$dp_1 = m z_1 = 48$	$dp_2 = m z_2 = 112$
passo	$P = m\pi = 12,56$	
espessura circular e vão	$s = v = P/2 = 6,28$	
espessura cordal	$sc_1 = m z_1 \sin \alpha_1 = 6,265$	$sc_2 = m z_2 \sin \alpha_2 = 6,251$
diâmetro externo	$de_1 = m (z_1 + 2) = 56$	$de_2 = m (z_2 + 2) = 120$
diâmetro interno	$di_1 = m (z_1 - 2,334) = 38,664$	$di_2 = m (z_2 - 2,334) = 102,664$
ângulo de pressão	$\theta = 20^\circ$	
diâm. do círc. de base	$db_1 = dp_1 \cos \theta = 45,105$	$db_2 = dp_2 \cos \theta = 105,245$
altura da cabeça do dente	$a = m = 4$	
altura da cabeça (cordal)	$ac_1 = m \left[1 + \frac{z_1}{2} (1 - \cos \alpha_1) \right] = 4,205$	$ac_2 = m \left[1 + \frac{z_2}{2} (1 - \cos \alpha_2) \right] = 4,087$
altura do pé do dente	$b = 1,167 m = 4,668$	
altura do dente	$h = a + b = 8,668$	
folga no pé do dente	$e = 0,167 m = 0,668$	
relação de transmissão	$\varphi = z_1/z_2 = 0,43 = 1:2,34 = 3:7$	
dist. entre centros	$I = (dp_1 + dp_2)/2 = 80$	
comprimento do dente	$l = (6 \div 20) m = 30$	
ângulo do dente	$\alpha_1 = \frac{90}{z_1} = 7^\circ 30'$	$\alpha_2 = \frac{90}{z_2} = 3^\circ 12'$

ENGRENAGENS CILÍNDRICAS DE DENTES HELICOIDAIS

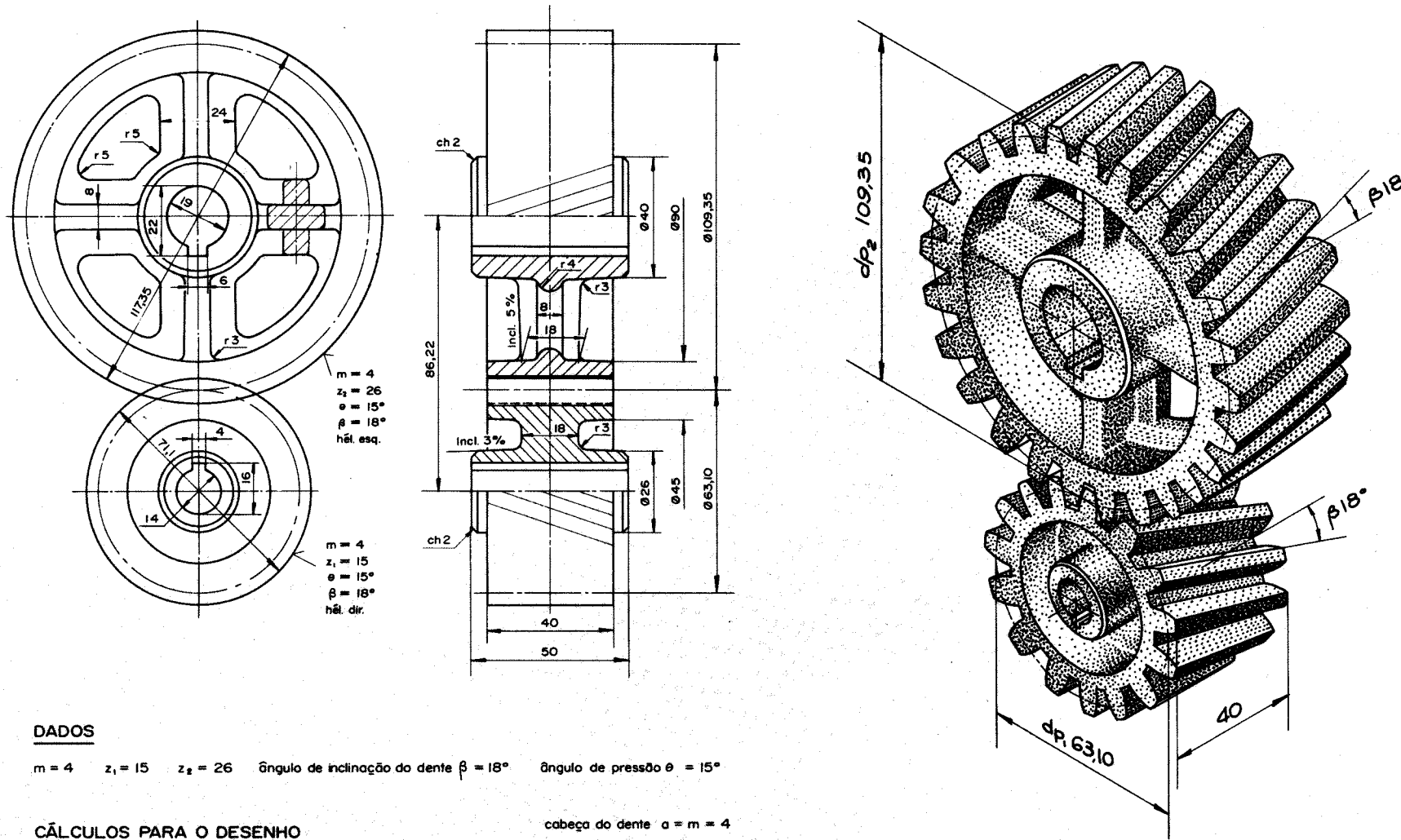

$m = 4$
 $z_1 = 26$
 $\theta = 15^\circ$
 $\beta = 18^\circ$
 hél. esq.

 $m = 4$
 $z_2 = 15$
 $\theta = 15^\circ$
 $\beta = 18^\circ$
 hél. dir.

DADOS

$m = 4$ $z_1 = 26$ $z_2 = 15$ ângulo de inclinação do dente $\beta = 18^\circ$ ângulo de pressão $\theta = 15^\circ$

CÁLCULOS PARA O DESENHO

diâm. primitivo do pinhão $d_p = m z_1 / \cos \beta = 63,08 \approx 63,10$

diâm. primitivo da coroa $d_{p_2} = m z_2 / \cos \beta = 109,35$

cabeça do dente $a = m = 4$

pé do dente $b = 1,167 m = 4,668$

largura da engrenagem $l \approx 3 m \pi / \cos \beta \approx 40$

CÁLCULOS

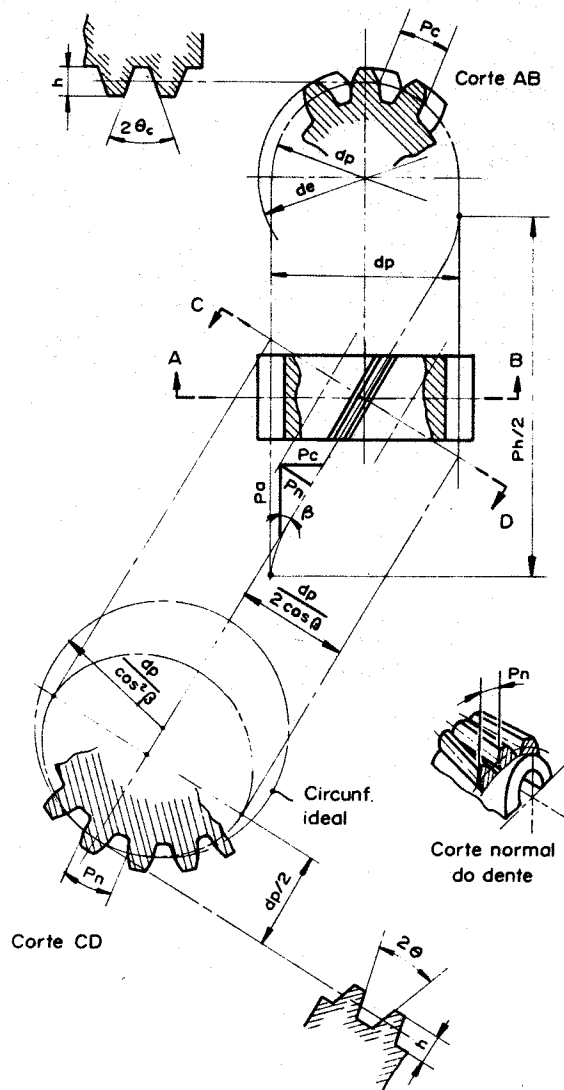

DESCRIÇÃO	PINHÃO	COROA
número de dentes	$z_1 = 15$	$z_2 = 26$
número de dentes ideal	$z_{id1} = z_1 / \cos^3 \beta = 17,424$ (Escolha de fresa)	$z_{id2} = z_2 / \cos^3 \beta = 30,218$
módulo circunferencial	$m_c = m / \cos \beta = 4,206$	
módulo normal	$m = 4$	
módulo axial	$m_a = m / \sin \beta = 12,944$	
diâmetro primitivo	$dp_1 = m_c \cdot z_1 = 63,10$	$dp_2 = m_c \cdot z_2 = 109,35$
diâmetro externo	$de_1 = dp_1 + 2m = 71,10$	$de_2 = dp_2 + 2m = 117,35$
diâmetro primitivo ideal	$dp_{i1} = dp_1 / \cos^2 \beta = 69,732$	$dp_{i2} = dp_2 / \cos^2 \beta = 120,907$
diâmetro interno	$di_1 = dp_1 - 2,334m = 53,764$	$di_2 = dp_2 - 2,334m = 100,014$
altura da cabeça do dente	$a = m = 4$	
altura do pé do dente	$b = 1,167m = 4,668$	
folga no pé do dente	$e = 0,167m = 0,668$	
esp. circ. aparente do dente	$s = m_c \pi / 2 = 6,594$	
esp. cord. aparente do dente	$sc_1 = m_c z_1 \sin \alpha_1 = 6,585$	$sc_2 = m_c z_2 \sin \alpha_2 = 6,588$
passo normal	$P_n = m \pi = 12,56$	
passo circunferencial	$P_c = m_c \pi = 13,188$	
passo da hélice	$Ph_1 = z_1 P_n / \sin \beta = 609,669$	$Ph_2 = z_2 P_n / \sin \beta = 1056,828$
passo axial	$Pa = P_n / \sin \beta = 40,64$	
ângulo de pressão	$\theta = 15^\circ$	
ângulo de pressão circunf.	$\operatorname{tg} \theta_c = \operatorname{tg} \theta / \cos \beta = 0,356 \therefore \theta_c = 19^\circ 35'$	
âng. de inclinação da hélice	$\beta = 8^\circ + 30^\circ \therefore \beta = 38^\circ$	
distância entre centros	$I = (dp_1 + dp_2) / 2 = 86,22$	
relação de transmissão	$\varphi = z_1 / z_2 = 0,57 = 1:1,73$	
largura da engrenagem	$l = (6 \div 16)m = 40$	
ângulo do dente	$\alpha_1 = 90^\circ / z_1 = 6^\circ$	$\alpha_2 = 90^\circ / z_2 = 3^\circ 27'$

ENGRENAGENS CÔNICAS

SEQUÊNCIA DO TRAÇADO

DADOS: δ , m , Z_1 , Z_2

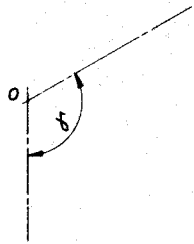
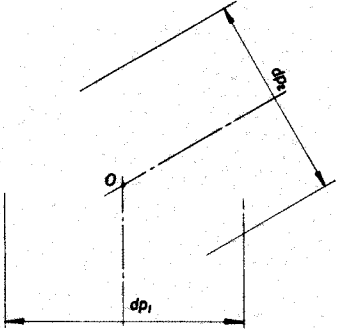
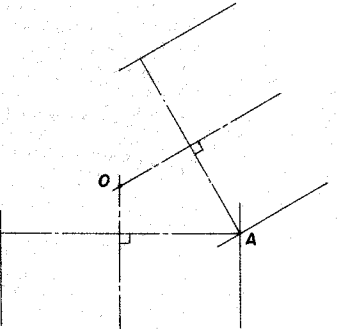
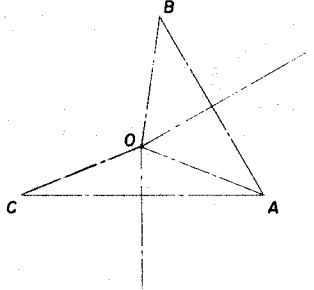
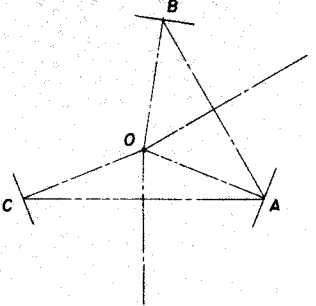
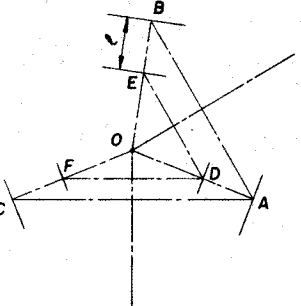
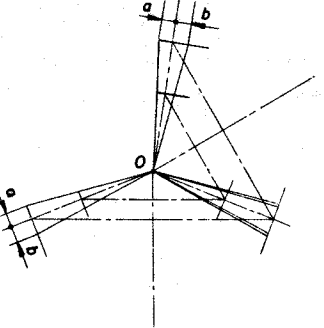
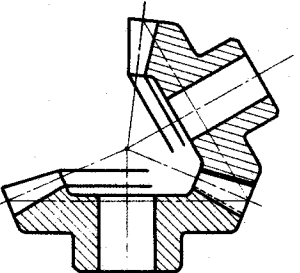
<p>① TRAÇAR OS EIXOS.</p> 	<p>② TRAÇAR OS LUGARES GEOMÉTRICOS DOS DIÂMETROS PRIMITIVOS. ($dp_1 = m Z_1$; $dp_2 = m Z_2$).</p> 	<p>③ TRAÇAR AS PERPENDICULARES AOS EIXOS PELO PONTO A.</p> 	<p>④ LIGAR OS PONTOS ABC COM O CENTRO O, OBTENDO ASSIM OS CONES PRIMITIVOS.</p> 
<p>⑤ TRAÇAR AS PERPENDICULARES ÀS GERATRIZES PELOS PONTOS ABC.</p> 	<p>⑥ MARCAR O COMPRIMENTO ℓ DO DENTE NAS GERATRIZES E TRAÇAR AS PERPENDICULARES PELOS PONTOS DEF.</p> 	<p>⑦ MARCAR A CABEÇA ($a=m$) E O PÉ ($b=1,167m$) DO DENTE.</p> 	<p>⑧ COMPLETAR AS ENGRENAGENS COM OS DADOS DO PROJETO.</p> 

ENGRENAGENS CÔNICAS A 90°

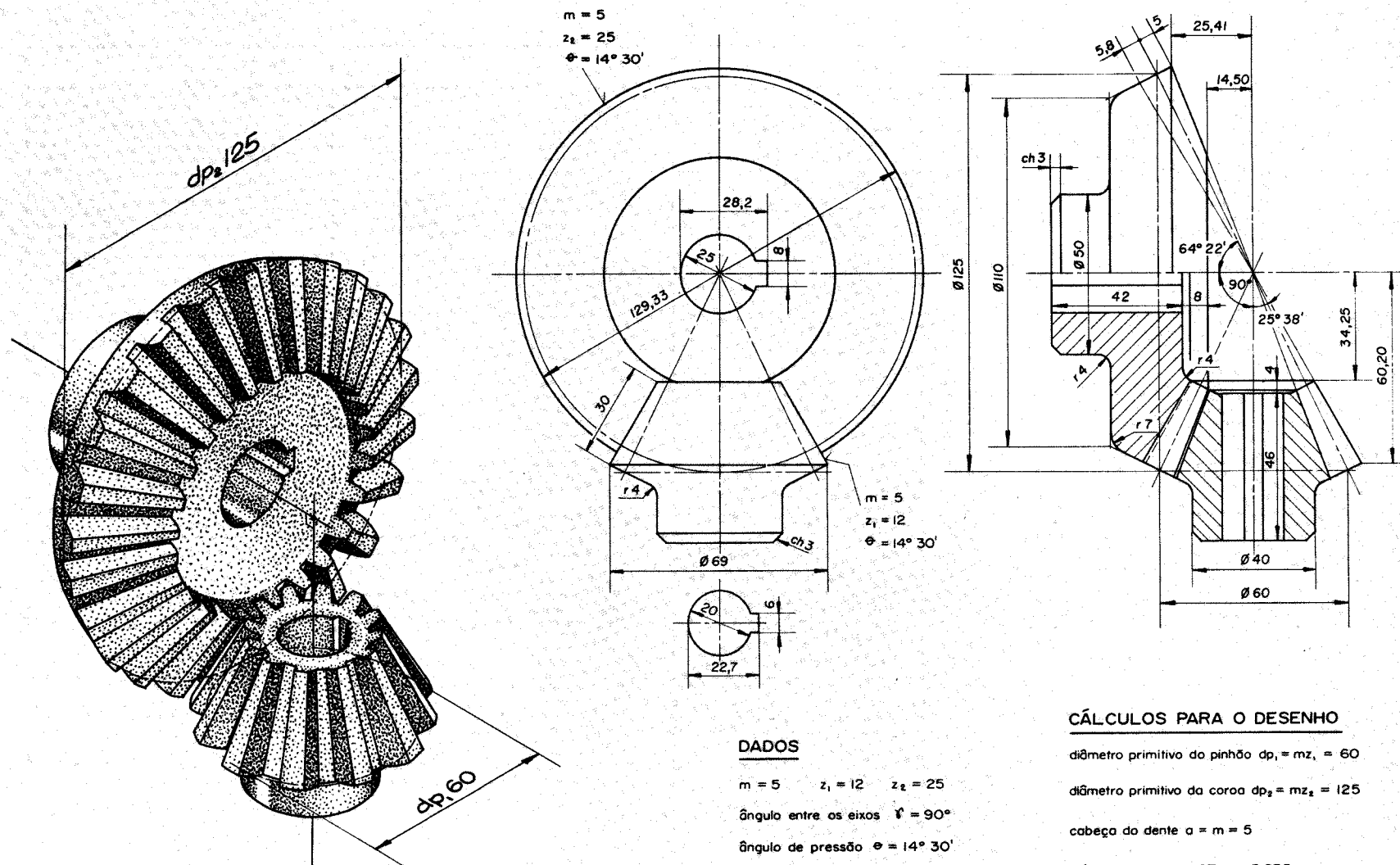

DADOS

$m = 5$ $z_1 = 12$ $z_2 = 25$
 ângulo entre os eixos $\gamma = 90^\circ$
 ângulo de pressão $\phi = 14^\circ 30'$

CÁLCULOS PARA O DESENHO

diâmetro primitivo do pinhão $dp_1 = mz_1 = 60$
 diâmetro primitivo da coroa $dp_2 = mz_2 = 125$
 cabeça do dente $a = m = 5$
 pé do dente $b = 1,167m = 5,835$
 comprimento do dente $l = (5 + 12)m = 30$

CÁLCULOS

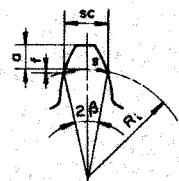
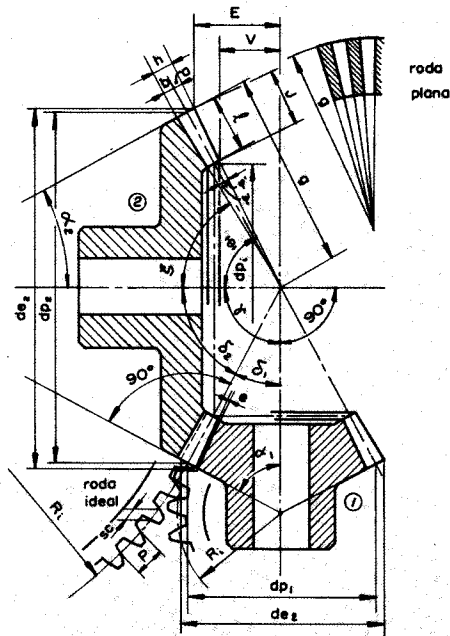

DESCRIÇÃO	PINHÃO	COROA
número de dentes	$z_1 = 12$	$z_2 = 25$
nº de dentes da roda ideal	$z_{i1} = z_1 / \cos \delta_1 = 13,309$	$z_{i2} = z_2 / \cos \delta_2 = 57,788$
nº de dentes da roda plana	$z_{p1} = z_1 / \sin \delta_1 = 27,738$	$z_{p2} = z_2 / \sin \delta_2 = 27,729$
diâmetro primitivo	$dp_1 = m z_1 = 60$	$dp_2 = m z_2 = 125$
diâmetro primitivo interno	$dp_{i1} = dp_1 - 2l \sin \delta_1 = 34,04$	$dp_{i2} = dp_2 - 2l \sin \delta_2 = 70,905$
diâmetro externo	$de_1 = dp_1 + 2a \cos \delta_1 = 69,015$	$de_2 = dp_2 + 2a \cos \delta_2 = 129,326$
módulo	$m = 5$	
passo circular	$P = m\pi = 15,70$	
cabeça do dente	$a = m = 5$	
pé do dente	$b = 1,167 m = 5,835$	
altura total do dente	$h = a + b = 10,835$	
folga no pé do dente	$e = 0,167 m = 0,835$	
âng. de incl. dos eixos	$\gamma = 90^\circ$	
semi-âng. do cone primitivo	$\text{arc tg } \delta_1 = \text{sen } \gamma' / (1/\psi + \cos \gamma') = 25^\circ 38'$	$\text{arc tg } \delta_2 = \text{sen } \gamma' / (\psi + \cos \gamma') = 64^\circ 22'$
semi-âng. do cone externo	$\phi_1 = \delta_1 + \psi' = 29^\circ 46'$	$\phi_2 = \delta_2 + \psi' = 68^\circ 30'$
semi-âng. do cone interno	$\xi_1 = \delta_1 - \psi = 20^\circ 50'$	$\xi_2 = \delta_2 - \psi = 59^\circ 34'$
semi-âng. do cone complementar	$\alpha_1 = 90^\circ - \delta_1 = 64^\circ 22'$	$\alpha_2 = 90^\circ - \delta_2 = 25^\circ 38'$
ângulo da cabeça do dente	$\text{arc tg } \psi' = m/g = 4^\circ 8'$	
âng. do pé do dente	$\text{arc tg } \psi = b/g = 4^\circ 48'$	
geratriz primitiva	$g = dp_1 / 2 \sin \delta_1 = 69,34$	$g = dp_2 / 2 \sin \delta_2 = 69,34$
geratriz do cone complementar	$R_{i1} = dp_1 / 2 \cos \delta_1 = 33,3$	$R_{i2} = dp_2 / 2 \cos \delta_2 = 144,4$
geratriz do dente	$J = l / \cos \psi' = 30$	
comprimento do dente	$l = (5 + 12) m = 30$	
flecha do dente	$f_1 = R_{i1} - R_{i1} \cos \beta_1 = 0,234$	$f_2 = R_{i2} - R_{i2} \cos \beta_2 = 0,145$
espes. cordal do dente	$sc_1 = 2 R_{i1} \sin \beta_1 = 7,828$	$sc_2 = 2 R_{i2} \sin \beta_2 = 7,812$
dist. do vért. ao dente (superior)	$V_1 = (g - l) \cos \phi_1 = 34,249$	$V_2 = (g - l) \cos \phi_2 = 14,418$
dist. do vért. ao dente (inferior)	$E_1 = g \cos \phi_1 = 60,19$	$E_2 = g \cos \phi_2 = 25,41$
relação de transmissão	$\psi = z_1 / z_2 = 0,48 = 1 : 2,083$	
ângulo do dente	$\beta_1 = 90^\circ / z_1 = 6,76 \dots 6^\circ 45'$	$\beta_2 = 90^\circ / z_{i2} = 1,55 \dots 1^\circ 33'$

ENGRENAGENS CÔNICAS A 90° - SISTEMA PITCH

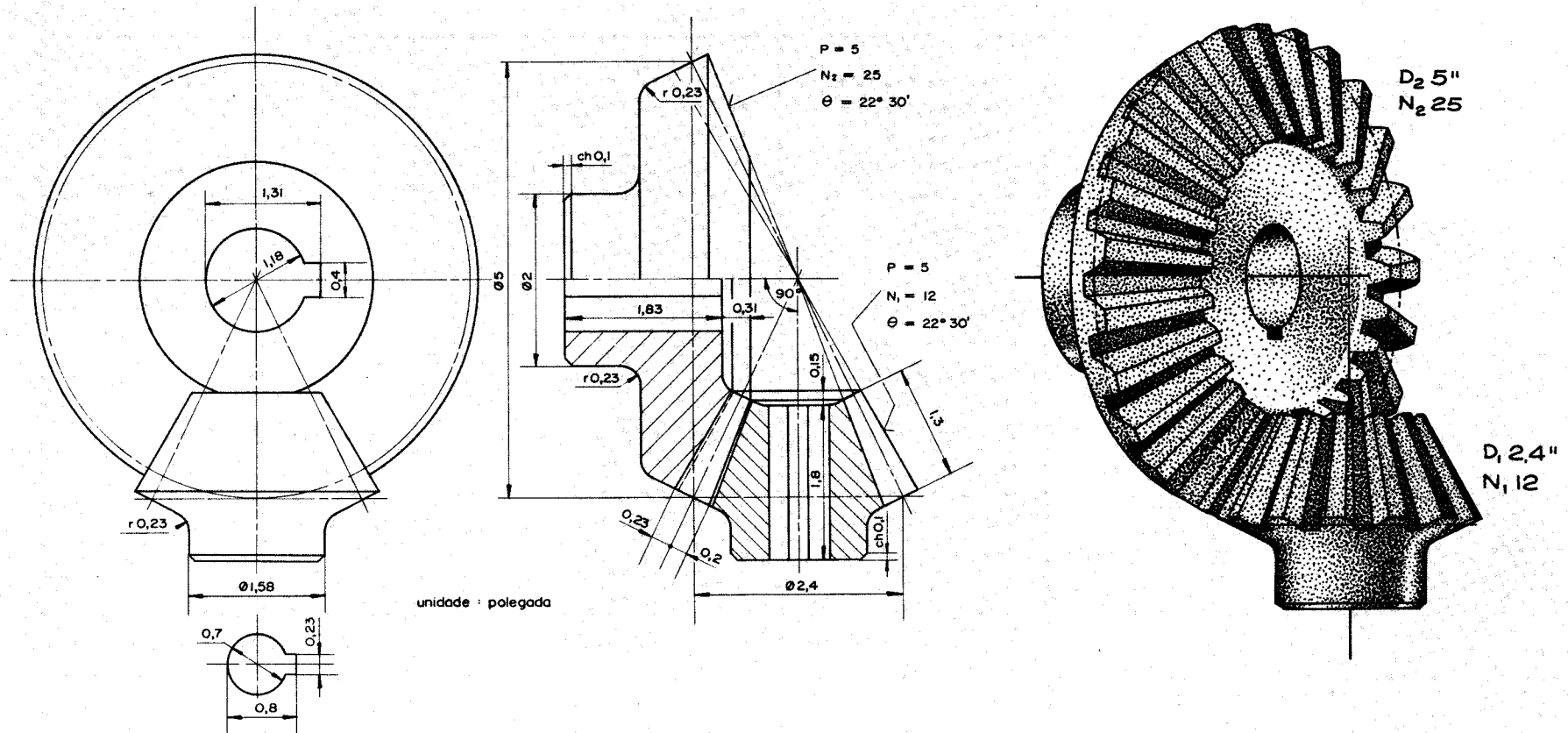

unidade : polegada

DADOS

Diametral Pitch $P = 5$ $N_1 = 12$ $N_2 = 25$
 $\theta = 22^\circ 30'$

CÁLCULOS PARA O DESENHO

diâmetro primitivo do pinhão $D_1 = N_1 / P = 2,4$
diâmetro primitivo da coroa $D_2 = N_2 / P = 5$

cabeça do dente $A = 1/P = 0,2$

pé do dente $B = 1,571/P = 0,23$

comprimento do dente $L = (5 - 12)/P = 33 = 1,3$

CÁLCULOS

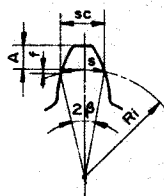
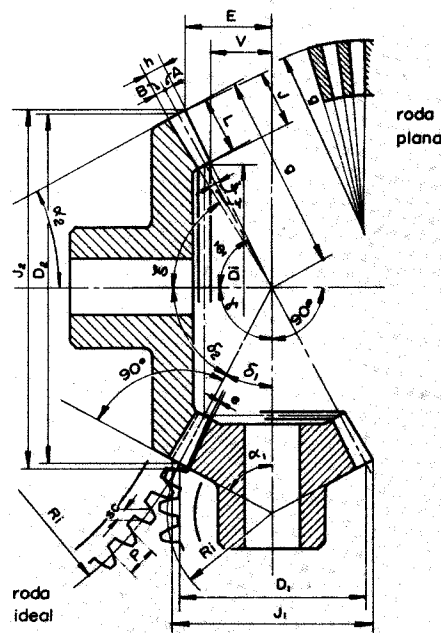

DESCRIÇÃO	PINHÃO	COROA
número de dentes	$N_1 = 12$	$N_2 = 25$
nº de dentes da roda ideal	$N_{i1} = N_1 / \cos \delta_1 = 13,309$	$N_{i2} = N_2 / \cos \delta_2 = 57,788$
nº de dentes da roda plana	$N_{p1} = N_1 / \sin \delta_1 = 27,738$	$N_{p2} = N_2 / \sin \delta_2 = 27,729$
diâmetro primitivo	$D_1 = N_1 / P = 2,4$	$D_2 = N_2 / P = 5$
diâmetro primitivo interno	$D_{i1} = D_1 - 2L \sin \delta_1 = 1,276$	$D_{i2} = D_2 - 2L \sin \delta_2 = 2,658$
diâmetro externo	$J_1 = D_1 + 2A \cos \delta_1 = 2,760$	$J_2 = D_2 + 2A \cos \delta_2 = 5,173$
diâmetro pitch	$P = 5$	
circular pitch	$P' = \pi / P = 0,628$	
cabeça do dente	$A = 1 / P = 0,2$	
pé do dente	$B = 1,1571 / P = 0,231$	
altura total do dente	$h = A + B = 0,43$	
talga no pé do dente	$e = 0,1571 / P = 0,031$	
âng. de inclin. dos eixos	$\gamma = 90^\circ$	
semi-âng. do cone primitivo	$\arctg \delta_1 = \text{sen } \gamma / (\psi + \cos \gamma) = 25^\circ 38'$	$\arctg \delta_2 = \text{sen } \gamma / (\psi + \cos \gamma) = 64^\circ 22'$
semi-âng. do cone externo	$\phi_1 = \delta_1 + \psi' = 29^\circ 46'$	$\phi_2 = \delta_2 + \psi' = 68^\circ 30'$
semi-âng. do cone interno	$\xi_1 = \delta_1 - \psi' = 20^\circ 52'$	$\xi_2 = \delta_2 - \psi' = 59^\circ 34'$
semi-âng. do cone complementar	$\alpha_1 = 90^\circ - \delta_1 = 64^\circ 22'$	$\alpha_2 = 90^\circ - \delta_2 = 25^\circ 38'$
ângulo da cabeça do dente	$\arctg \psi' = A/g = 4^\circ 8'$	
âng. do pé do dente	$\arctg \psi' = B/g = 4^\circ 46'$	
geratriz primitiva	$g_1 = D_1 / 2 \text{sen } \delta_1 = 2,774$	$g_2 = D_2 / 2 \text{sen } \delta_2 = 2,777$
geratriz do cone complementar	$R_{i1} = D_1 / 2 \cos \delta_1 = 1,333$	$R_{i2} = D_2 / 2 \cos \delta_2 = 5,780$
geratriz do dente	$J = L / \cos \psi' = 1,3$	
comprimento do dente	$L = (5 + 12) / P = 33 = 1,3$	
flecha do dente	$f_1 = R_{i1} - R_{i1} \cos \beta_1 = 0,01$	$f_2 = R_{i2} - R_{i2} \cos \beta_2 = 0,006$
espes. cordal do dente	$sc_1 = 2 R_{i1} \text{sen } \beta_1 = 0,312$	$sc_2 = 2 R_{i2} \text{sen } \beta_2 = 0,312$
dist. do vért. ao dente (superior)	$V_1 = (g_1 - L) \cos \phi_1 = 1,279$	$V_2 = (g_2 - L) \cos \phi_2 = 0,560$
dist. vért. ao dente (inferior)	$E_1 = g_1 \cos \phi_1 = 2,407$	$E_2 = g_2 \cos \phi_2 = 1,016$
relação de transmissão	$\varphi = N_1 / N_2 = 0,48 = 1:2,083$	
ângulo do dente	$\beta_1 = 90^\circ / N_{i1} = 6,76 \dots 6^\circ 45'$	$\beta_2 = 90^\circ / N_{i2} = 1,55 \dots 1^\circ 33'$

ENGRENAGENS CÔNICAS A 75°

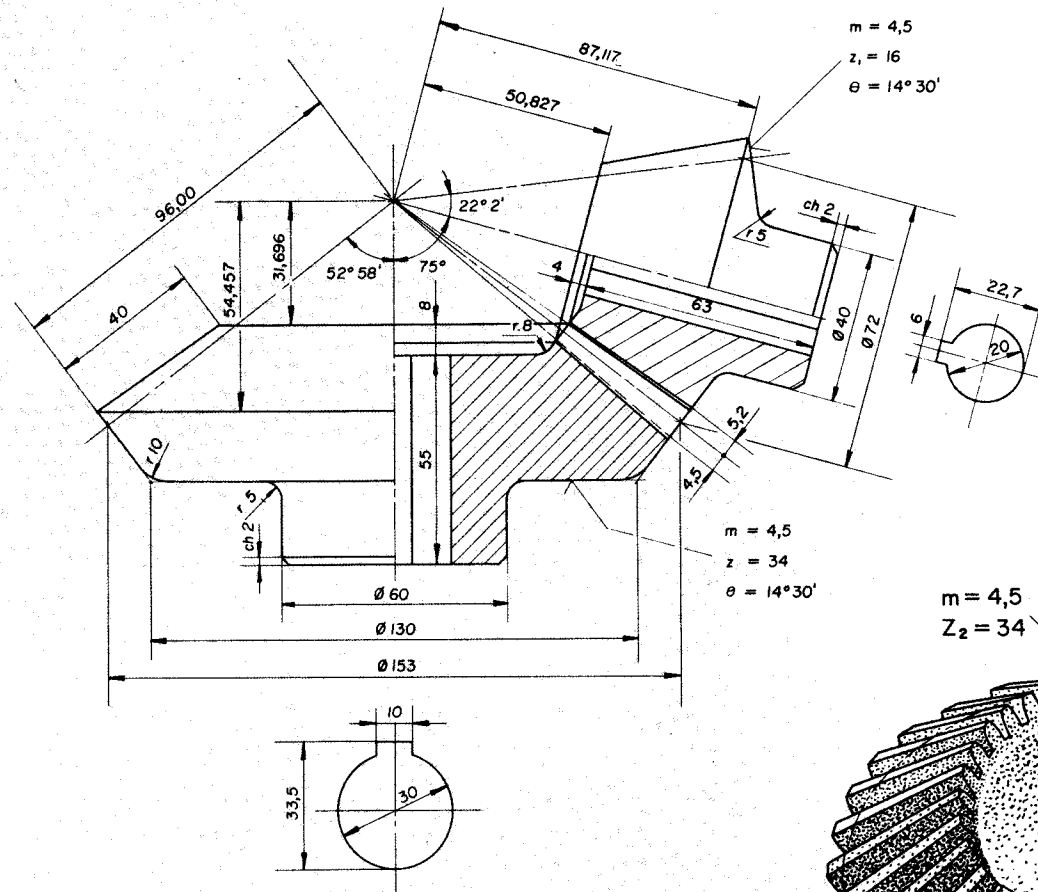

$m = 4,5$
 $z_1 = 16$
 $\theta = 14^\circ 30'$

$m = 4,5$
 $z = 34$
 $\theta = 14^\circ 30'$

$m = 4,5$
 $Z_2 = 34$

$m = 4,5$
 $Z_1 = 16$

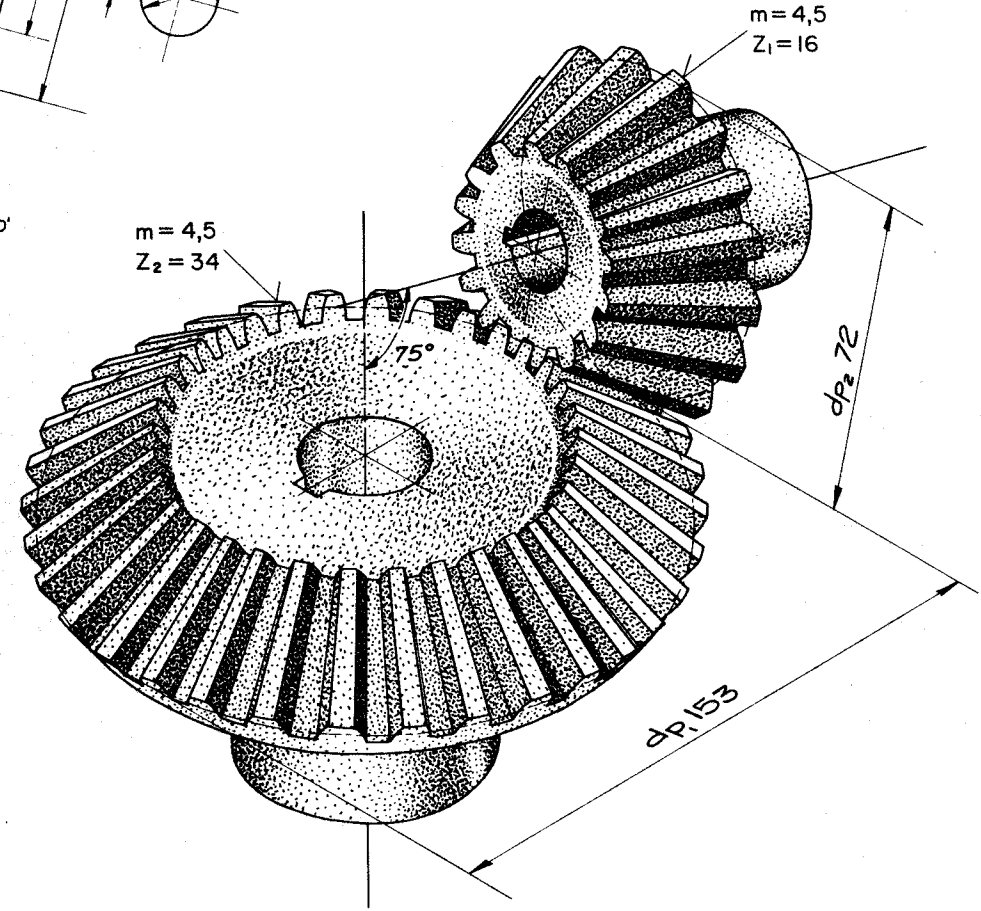

DADOS

$m = 4,5$ $z_1 = 16$ $z_2 = 34$ $\hat{\gamma} = 75^\circ$ $\theta = 14^\circ 30'$

CÁLCULOS PARA O DESENHO

diâmetro primitivo do pinhão $dp_1 = mz_1 = 72$

diâmetro primitivo da coroa $dp_2 = mz_2 = 153$

cabeça do dente $a = m = 4,5$

pé do dente $b = 1,167m = 5,251$

comprimento do dente $l = (5 - 12)m = 40$

CÁLCULOS

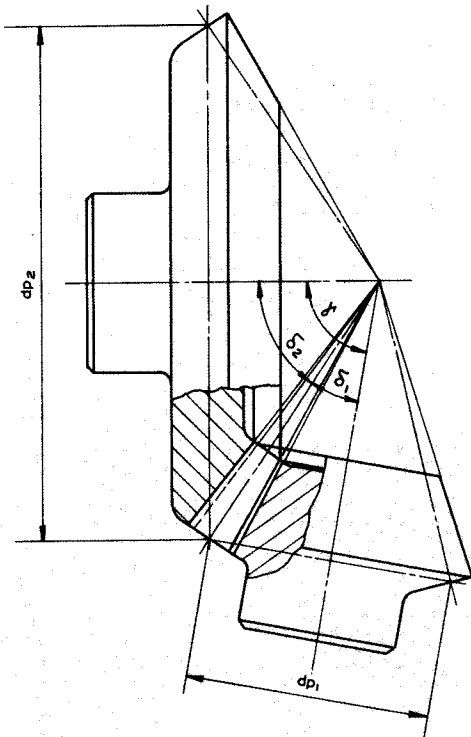

DESCRIÇÃO	PINHÃO	COROA
número de dentes	$z_1 = 16$	$z_2 = 34$
nº de dentes da roda ideal	$z_{i1} = z_1 / \cos \delta_1 = 16,610$	$z_{i2} = z_2 / \cos \delta_2 = 56,452$
nº de dentes da roda plana	$z_{p1} = z_1 / \sin \delta_1 = 42,649$	$z_{p2} = z_2 / \sin \delta_2 = 42,591$
diâmetro primitivo	$dp_1 = m z_1 = 72$	$dp_2 = m z_2 = 153$
diâmetro primitivo interno	$dpi_1 = dp_1 - 2l \sin \delta_1 = 41,988$	$dpi_2 = dp_2 - 2l \sin \delta_2 = 89,136$
diâmetro externo	$de_1 = dp_1 + 2a \cos \delta_1 = 80,667$	$de_2 = dp_2 + 2a \cos \delta_2 = 158,420$
módulo	$m = 4,5$	
passo circular	$P = m\pi = 14,13$	
cabeça do dente	$a = m = 4,5$	
pé do dente	$b = 1,167 m = 5,251$	
altura total do dente	$h = a + b = 9,751$	
folga no pé do dente	$e = 0,167 m = 0,751$	
âng. de inclin. dos eixos	$\delta = 75^\circ$	
semi-âng. do cone primitivo	$\arctg \delta_1 = \sin \delta / (\cos \varphi + \cos \delta) = 22^\circ 2'$	$\arctg \delta_2 = \sin \delta / (\cos \varphi + \cos \delta) = 52^\circ 58'$
semi-âng. do cone externo	$\phi_1 = \delta_1 + \varphi' = 24^\circ 44'$	$\phi_2 = \delta_2 + \varphi' = 55^\circ 30'$
semi-âng. do cone interno	$\xi_1 = \delta_1 - \psi = 18^\circ 52'$	$\xi_2 = \delta_2 - \psi = 49^\circ 50'$
semi-âng. do cone complementar	$\alpha_1 = 90^\circ - \delta_1 = 67^\circ 58'$	$\alpha_2 = 90^\circ - \delta_2 = 37^\circ 2'$
ângulo da cabeça do dente	$\arctg \varphi' = m/g = 2^\circ 42'$	
âng. do pé do dente	$\arctg \psi = b/g = 3^\circ 8'$	
geratriz primitiva	$g = dp_1 / 2 \sin \delta_1 = 95,961 \cong 96$	$g = dp_2 / 2 \sin \delta_2 = 95,829 \cong 96$
geratriz do cone complementar	$R_{i1} = dp_1 / 2 \cos \delta_1 = 37,384$	$R_{i2} = dp_2 / 2 \cos \delta_2 = 127,017$
geratriz do dente	$J = l / \cos \varphi' = 39,93 \cong 40$	
comprimento do dente	$l = (5 + 12) m = 40$	
flecha do dente	$f_1 = R_{i1} - R_{i1} \cos \beta_1 = 0,166$	$f_2 = R_{i2} - R_{i2} \cos \beta_2 = 0,128$
espes. cordal do dente	$sc_1 = 2 R_{i1} \sin \beta_1 = 7,274$	$sc_2 = 2 R_{i2} \sin \beta_2 = 7,069$
dist. do vért. ao dente (superior)	$V_1 = (g - l) \cos \phi_1 = 50,827$	$V_2 = (g - l) \cos \phi_2 = 31,696$
dist. do vért. ao dente (inferior)	$E_1 = g \cos \xi_1 = 87,117$	$E_2 = g \cos \xi_2 = 54,457$
relação de transmissão	$\varphi = z_1 / z_2 = 0,470 = 1 : 2,125$	
ângulo do dente	$\beta_1 = 90^\circ / z_1 = 5,41 = 5^\circ 24'$	$\beta_2 = 90^\circ / z_2 = 1,59 = 1^\circ 35'$

ENGRENAGENS CÔNICAS A 120°

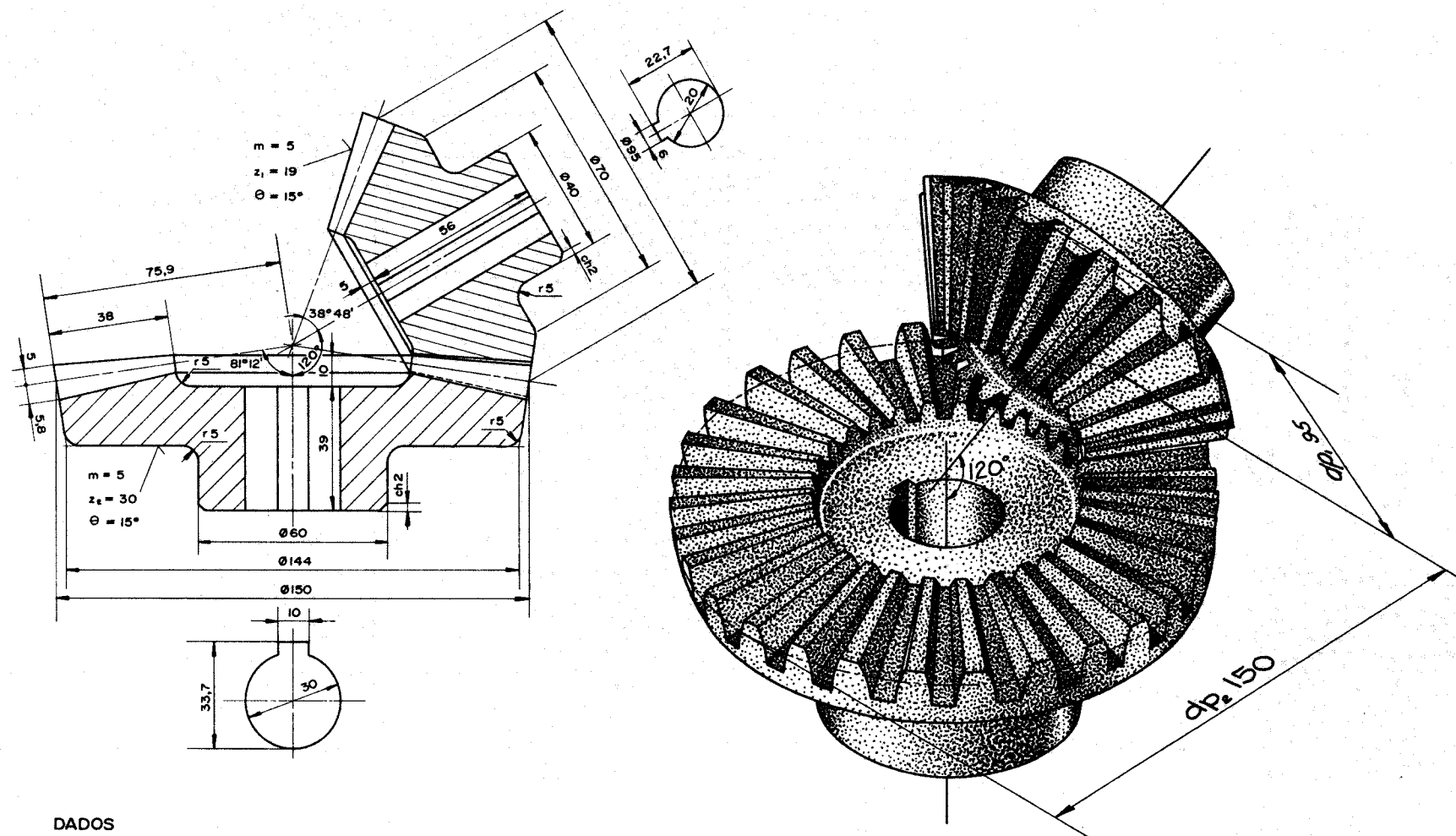

DADOS

$m = 5$ $z_1 = 19$ $z_2 = 30$ $\gamma = 120^\circ$ $\theta = 15^\circ$

CÁLCULOS PARA O DESENHO

diâmetro primitivo do pinhão $dp_1 = mz_1 = 95$

diâmetro primitivo da coroa $dp_2 = mz_2 = 150$

cabeca do dente $a = m = 5$

pê do dente $b = 1,167m = 5,835$

comprimento do dente $l = (5 \div 2)m = 38$

CÁLCULOS

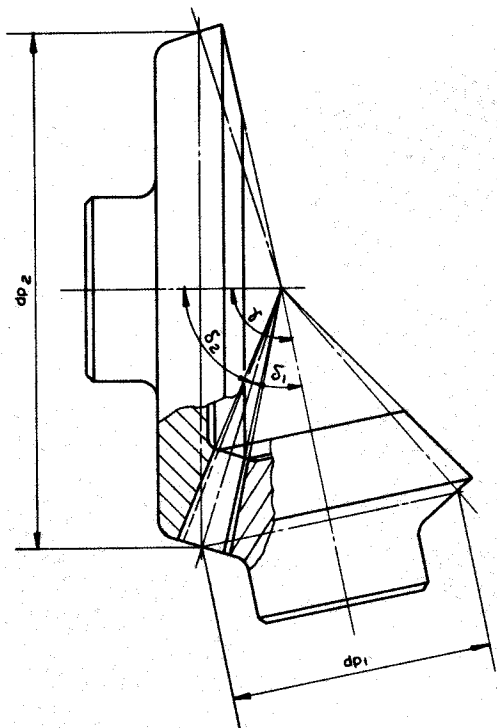

DESCRIÇÃO	PINHÃO	COROA
número de dentes	$z_1 = 19$	$z_2 = 30$
nº de dentes da roda ideal	$z_{i1} = z_1 / \cos \delta_1 = 24,271$	$z_{i2} = z_2 / \cos \delta_2 = 194,344$
nº de dentes da roda plana	$z_{p1} = z_1 / \sin \delta_1 = 30,535$	$z_{p2} = z_2 / \sin \delta_2 = 30,364$
diâmetro primitivo	$dp_1 = m z_1 = 95$	$dp_2 = m z_2 = 150$
diâmetro primitivo interno	$d_{pi1} = dp_1 - 2 \ell \sin \delta_1 = 47,379$	$d_{pi2} = dp_2 - 2 \ell \sin \delta_2 = 74,895$
diâmetro externo	$de_1 = dp_1 + 2 a \cos \delta_1 = 102,793$	$de_2 = dp_2 + 2 a \cos \delta_2 = 151,529$
módulo	$m = 5$	
passo circular	$P = m \pi = 15,70$	
cabeça do dente	$a = m = 5$	
pé do dente	$b = 1,167 m = 5,835$	
altura total do dente	$h = a + b = 10,835$	
folga no pé do dente	$e = 0,167 m = 0,835$	
âng. de inclin. dos eixos	$\gamma = 120^\circ$	
semi-âng. do cone primitivo	$\arctg \delta_1 = \text{sen } \gamma / (1/\varphi - \cos \gamma) = 38^\circ 48'$	$\arctg \delta_2 = \text{sen } \gamma / (\varphi - \cos \gamma) = 81^\circ 12'$
semi-âng. do cone externo	$\Phi_1 = \delta_1 + \varphi' = 42^\circ 34'$	$\Phi_2 = \delta_2 + \varphi' = 84^\circ 58'$
semi-âng. do cone interno	$\xi_1 = \delta_1 - \psi = 34^\circ 24'$	$\xi_2 = \delta_2 - \psi = 76^\circ 48'$
semi-âng. do cone complementar	$\alpha_1 = 90^\circ - \delta_1 = 51^\circ 12'$	$\alpha_2 = 90^\circ - \delta_2 = 8^\circ 48'$
ângulo da cabeça do dente	$\arctg \varphi' = m/g = 3^\circ 46'$	
âng. do pé do dente	$\arctg \psi = b/g = 4^\circ 24'$	
geratriz primitiva	$g = dp_1 / 2 \text{sen } \delta_1 \approx 75,9$	$g = dp_2 / 2 \text{sen } \delta_2 \approx 75,9$
geratriz do cone complementar	$R_{i1} = dp_1 / 2 \cos \delta_1 = 60,949$	$R_{i2} = dp_2 / 2 \cos \delta_2 = 490,228$
geratriz do dente	$J = \ell / \cos \varphi' = 38,082$	
comprimento do dente	$\ell = (5 + 12) m = 38$	
flecha do dente	$f_1 = R_{i1} - R_{i1} \cos \beta_1 = 0,127$	$f_2 = R_{i2} - R_{i2} \cos \beta_2 = 0,150$
espes. cordal do dente	$sc_1 = 2 R_{i1} \text{sen } \beta_1 = 7,830$	$sc_2 = 2 R_{i2} \text{sen } \beta_2 = 7,696$
dist. do vért. ao dente (superior)	$V_1 = (g - \ell) \cos \Phi_1 = 27,913$	$V_2 = (g - \ell) \cos \Phi_2 = 3,355$
dist. do vért. ao dente (inferior)	$E_1 = g \cos \xi_1 = 55,899$	$E_2 = g \cos \xi_2 = 6,659$
relação de transmissão	$\varphi = z_1 / z_2 = 0,634 = 1:1,579$	
ângulo do dente	$\beta_1 = 90^\circ / z_{i1} = 3,69 = 3^\circ 41'$	$\beta_2 = 90^\circ / z_{i2} = 0,45 = 0^\circ 27'$

COROA E ROSCA SEM-FIM

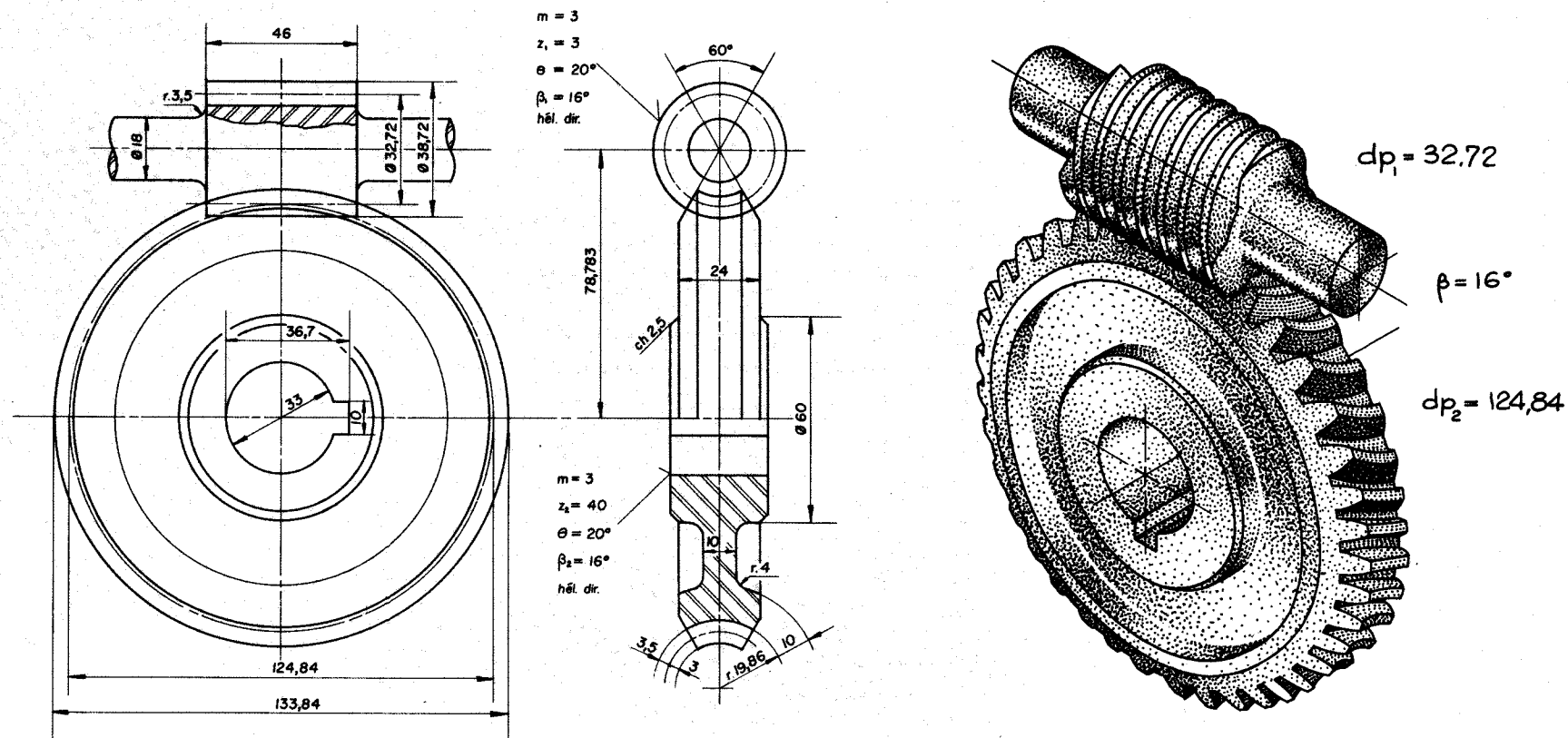

DADOS

$m = 3$ $z_1 = 3$ $z_2 = 40$
 $\beta_1 = 16^\circ$ hél. dir. $\beta_2 = 16^\circ$ hél. dir.
 $\theta = 20^\circ$

CÁLCULOS PARA O DESENHO

diâmetro primitivo da rêsca $dp_1 = mz_1 / \sin \beta = 32,72$
 diâmetro primitivo da coroa $dp_2 = mz_2 / \cos \beta = 124,84$
 cabeça do dente $a = m = 3$

pé do dente $b = 1,167m = 3,501$

ângulo do chanfro da coroa $\alpha_1 = 60^\circ \div 90^\circ \dots \alpha_1 = 60^\circ$

comprimento da rêsca $l_1 = 2 \frac{m}{\cos \beta} (1 + \sqrt{z_1}) = 46$

largura da coroa $l_2 = (6 \div 8)m = 24$

CÁLCULOS

β_1 é medido em relação ao plano normal ao eixo da rêsca.

β_2 é medido em relação ao eixo da coroa.

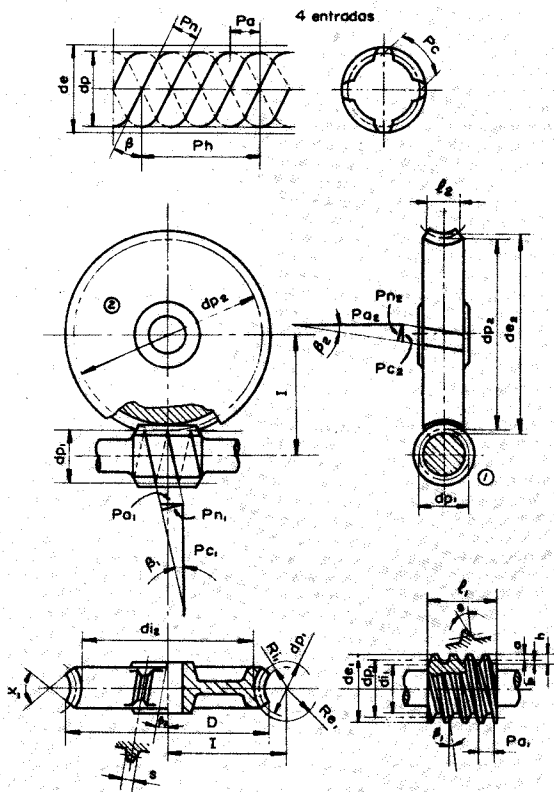

$$\beta_1 = \beta_2 = \beta$$

O valor de θ é escolhido de acordo com o valor de β

β	$\leq 12^\circ$	$12^\circ - 20^\circ$	$20^\circ - 25^\circ$	$> 25^\circ$
θ	$14^\circ 30'$	20°	$22^\circ 30'$	25°

DESCRIÇÃO	SEM-FIM	COROA
nº de dentes	$z_1 = 3$ entradas	$z_2 = 40$
módulo normal	$m = 3$	
módulo axial	$ma_1 = m / \cos \beta = 3,121$	$ma_2 = m / \sin \beta = 10,909$
módulo circunferencial	$mc_1 = m / \sin \beta = 10,909$	$mc_2 = m / \cos \beta = 3,121$
passo normal	$Pn = m\pi = 9,42$	
passo axial	$Pa_1 = ma_1\pi = 9,799$	$Pa_2 = ma_2\pi = 34,254$
passo circunferencial	$Pc_1 = mc_1\pi = 34,254$	$Pc_2 = mc_2\pi = 9,799$
passo da hélice	$Ph_1 = Pa_1 z_1 = 29,397$	$Ph_2 = Pa_2 z_2 = 1370,160$
diâmetro primitivo	$dp_1 = mc_1 z_1 = 32,727$	$dp_2 = mc_2 z_2 = 124,840$
diâmetro externo	$de_1 = dp_1 + 2m = 38,727$	$de_2 = dp_2 + 2m = 130,840$
diâmetro interno	$di_1 = dp_1 - 2,334 m = 25,725$	$di_2 = dp_2 - 2,334 m = 117,838$
altura da cabeça do dente	$a = m = 3$	
altura do pé do dente	$b = 1,167 m = 3,501$	
altura do dente	$h = a + b = 6,501$	
folga no pé do dente	$e = 0,167 m = 0,501$	
esp. circunferencial do dente	$s = Pn/2 = 4,71$	
diâm. máx. externo da coroa		$D \cong dp_2 + 3 m = 133,840$
largura da coroa		$l_2 = (6 \div 8) m = 24 < 0,75 de_1$
comprimento da sem-fim	$l_1 = 2 ma_1 (1 + \sqrt{z_2}) = 46$	
semi-ângulo do dente	$\theta = 20^\circ$	
ângulo da hélice	$\beta_1 = 16^\circ$	$\beta_2 = 16^\circ$
âng. do chanfro da coroa	$\alpha_1 = 60^\circ \div 90^\circ \therefore \alpha_1 = 60^\circ$	
raio externo da garganta		$Re = I - di_2/2 = 19,864$
raio interno da garganta		$Ri = I - de_2/2 = 13,363$
distância entre centros	$I = (dp_1 + dp_2)/2 = 78,783$	
relação de transmissão	$\psi = z_1/z_2 = 0,075 = 13,333$	

ENGRENAGENS HELICOIDAIS DE EIXOS ORTOGONAIS

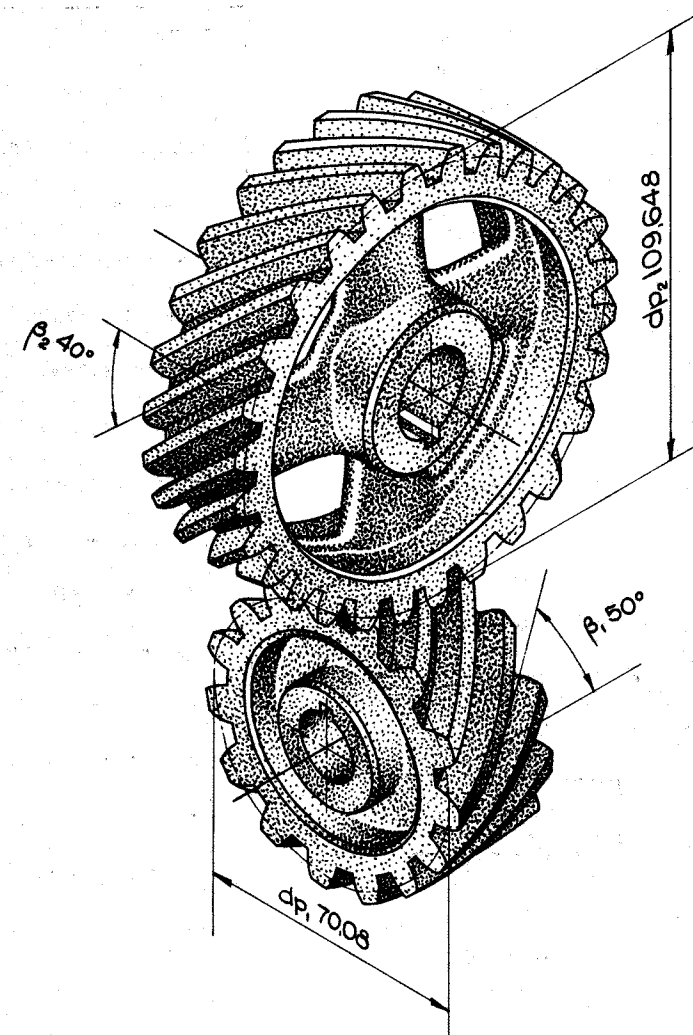
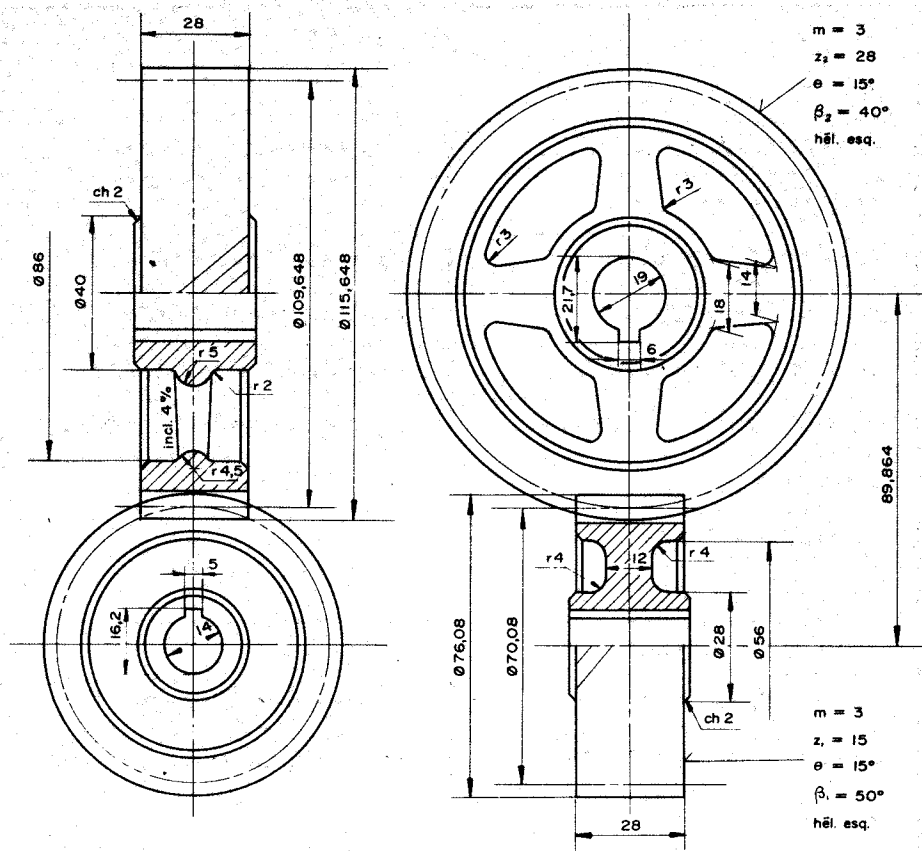

DADOS

$m = 3$ $z_1 = 15$ $z_2 = 28$ $\beta_1 = 50^\circ$ hêl. esq. $\beta_2 = 40^\circ$ hêl. esq. $e = 15^\circ$

CÁLCULOS PARA O DESENHO

diâmetro primitivo do pinhão $dp_1 = mz_1 / \cos \beta_1 = 70,08$

diâmetro primitivo da coroa $dp_2 = mz_2 / \cos \beta_2 = 109,648$

cabeca do dente $a = m = 3$

pé do dente $b = 1,167m = 3,501$

largura das engrenagens $l = (6 - 16)m = 28$

CALCULOS

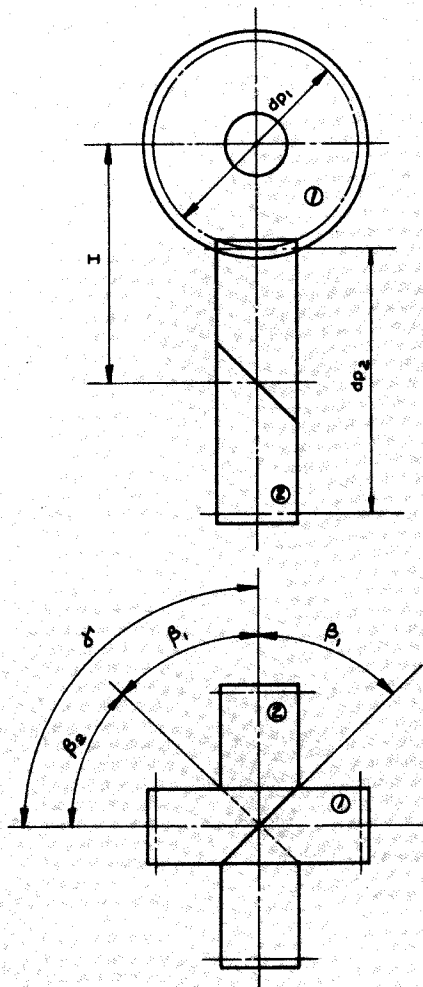

DESCRIÇÃO	PINHÃO	COROA
número de dentes	$z_1 = 15$	$z_2 = 28$
módulo normal	$m = 3$	
módulo circunferencial	$mc_1 = m / \cos \beta_1 = 4,672$	$mc_2 = m / \cos \beta_2 = 3,916$
passo normal	$P_n = m\pi = 9,42$	
passo circunferencial	$P_{c1} = mc_1\pi = 14,670$	$P_{c2} = mc_2\pi = 12,296$
diâmetro primitivo	$dp_1 = mc_1 z_1 = 70,080$	$dp_2 = mc_2 z_2 = 109,648$
diâmetro externo	$de_1 = dp_1 + 2m = 76,080$	$de_2 = dp_2 + 2m = 115,648$
diâmetro interno	$di_1 = dp_1 - 2,334m = 63,078$	$di_2 = dp_2 - 2,334m = 102,646$
altura da cabeça do dente	$a = m = 3$	
altura do pé do dente	$b = 1,167m = 3,501$	
altura do dente	$h = a + b = 6,501$	
folga no pé do dente	$e = 0,167m = 0,501$	
esp. circ. aparente do dente	$s_1 = mc_1\pi/2 = 7,335$	$s_2 = mc_2\pi/2 = 6,148$
esp. cord. aparente do dente	$sc_1 = mc_1 z_1 \sin \alpha_1 = 7,288$	$sc_2 = mc_2 z_2 \sin \alpha_2 = 6,030$
largura da engrenagem	$l = (6 \div 16)m = 28$	
ângulo de pressão	$\theta = 15^\circ$	
ângulo entre os eixos	$\delta = \beta_1 + \beta_2 = 50^\circ + 40^\circ = 90^\circ$	
distância entre centros	$I = (dp_1 + dp_2)/2 = 89,864$	
relação de transmissão	$\varphi = z_1/z_2 = 0,535 = 1:1,866$	
ângulo do dente	$\alpha_1 = 90^\circ/z_1 = 6^\circ$	$\alpha_2 = 90^\circ/z_2 = 3^\circ 12'$

ENGRENAGENS HELICOIDAIS DE EIXOS REVERSOS

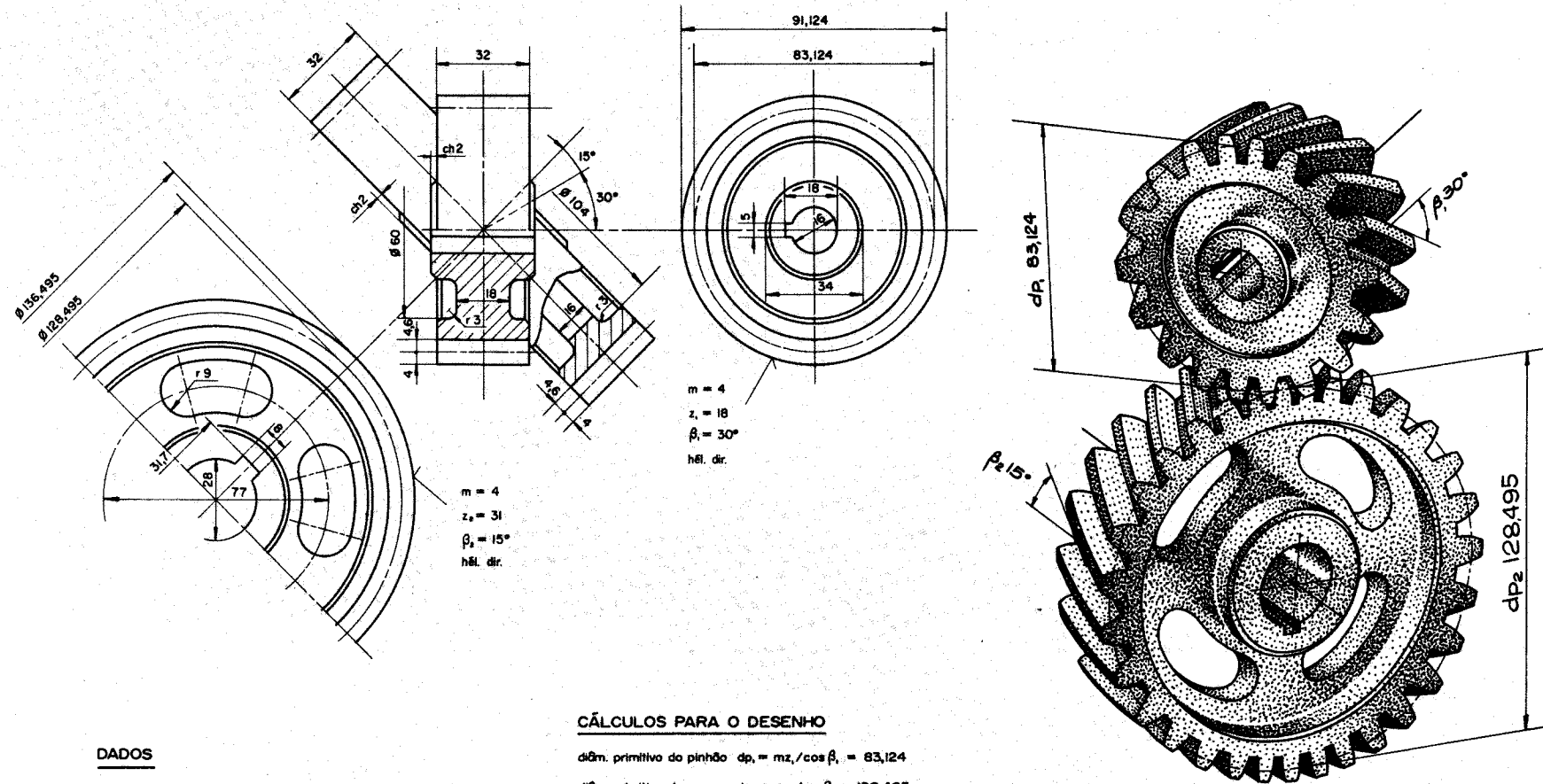

DADOS

$m = 4$ $z_1 = 18$ $z_2 = 31$
 $\beta_1 = 30^\circ$ héli. dir. $\beta_2 = 15^\circ$ héli. dir. $\theta = 20^\circ$

CÁLCULOS PARA O DESENHO

diâm. primitivo do pinhão $d_{p1} = m z_1 / \cos \beta_1 = 83,124$
 diâm. primitivo da coroa $d_{p2} = m z_2 / \cos \beta_2 = 128,495$
 cabeça do dente $a = m = 4$
 pé do dente $b = 1,167 m = 4,668$
 largura das engrenagens $\{ = (6 + 16) m = 32$

SEQUÊNCIA DO TRAÇADO

1ª etapa

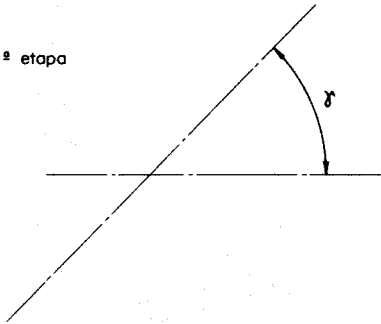

2ª etapa

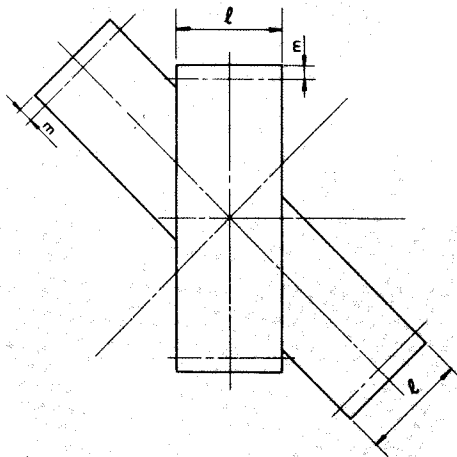
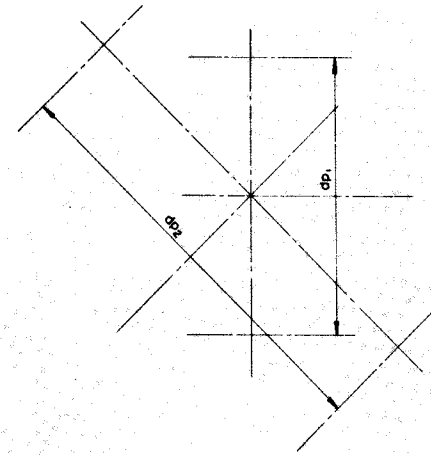
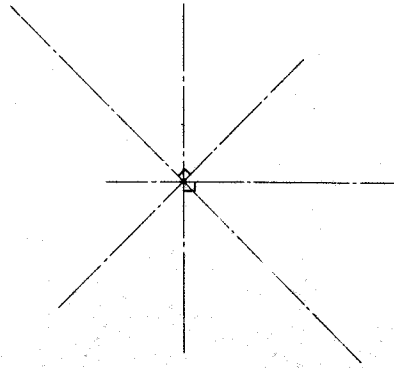

4ª etapa

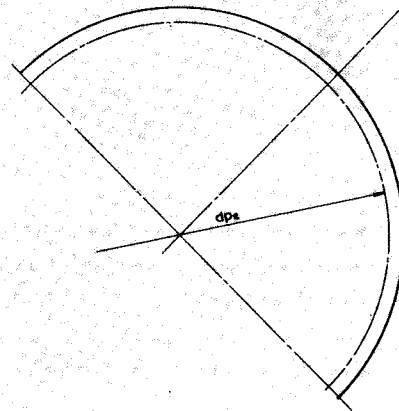

5ª etapa

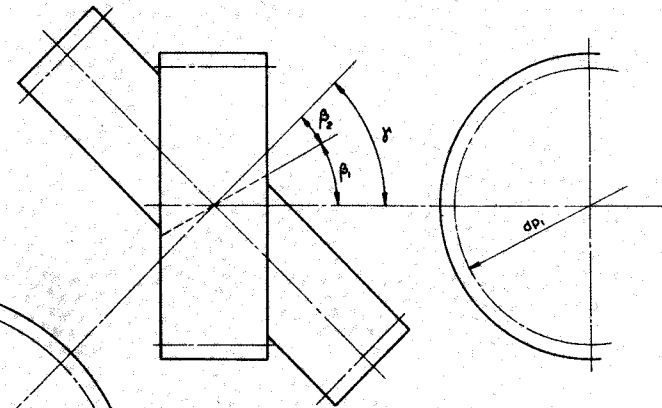

CÁLCULOS

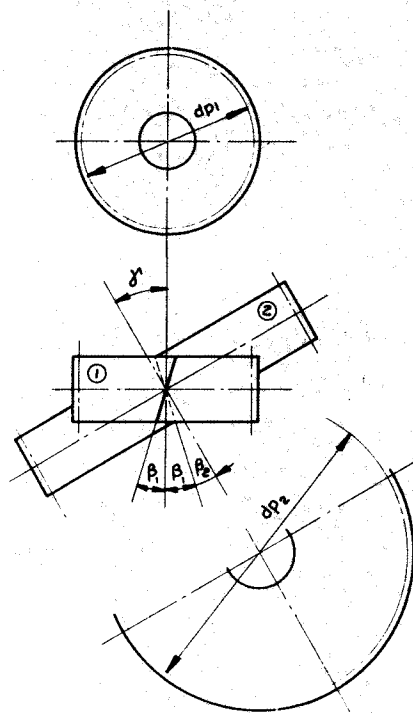

DESCRIÇÃO	PINHÃO	COROA
número de dentes	$z_1 = 18$	$z_2 = 31$
módulo normal	$m = 4$	
módulo circunferencial	$mc_1 = m / \cos \beta_1 = 4,618$	$mc_2 = m / \cos \beta_2 = 4,145$
passo normal	$Pn = m\pi = 12,56$	
passo circunferencial	$Pc_1 = mc_1 \pi = 14,500$	$Pc_2 = mc_2 \pi = 13,015$
diâmetro primitivo	$dp_1 = mc_1 z_1 = 83,124$	$dp_2 = mc_2 z_2 = 128,495$
diâmetro externo	$de_1 = dp_1 + 2m = 91,124$	$de_2 = dp_2 + 2m = 136,495$
diâmetro interno	$di_1 = dp_1 - 2,334m = 73,788$	$di_2 = dp_2 - 2,334m = 119,159$
altura da cabeça do dente	$a = m = 4$	
altura do pé do dente	$b = 1,167m = 4,668$	
altura do dente	$h = a + b = 8,668$	
folga no pé do dente	$e = 0,167m = 0,668$	
esp. circ. aparente do dente	$s_1 = mc_1 \pi / 2 = 7,250$	$s_2 = mc_2 \pi / 2 = 6,507$
esp. cord. aparente do dente	$sc_1 = mc_1 z_1 \sin \alpha_1 = 7,231$	$sc_2 = mc_2 z_2 \sin \alpha_2 = 6,424$
largura da engrenagem	$l = (6+16)m = 32$	
ângulo de pressão	$\theta = 20^\circ$	
ângulo entre os eixos	$\delta = \beta_1 + \beta_2 = 30^\circ + 15^\circ = 45^\circ$	
distância entre centros	$I = (dp_1 + dp_2) / 2 = 105,809$	
relação de transmissão	$\varphi = z_1 / z_2 = 0,58 = 1:1,722$	
ângulo do dente	$\alpha_1 = 90^\circ / z_1 = 5^\circ$	$\alpha_2 = 90^\circ / z_2 = 2^\circ 54'$

MUDANÇA DE MARCHA

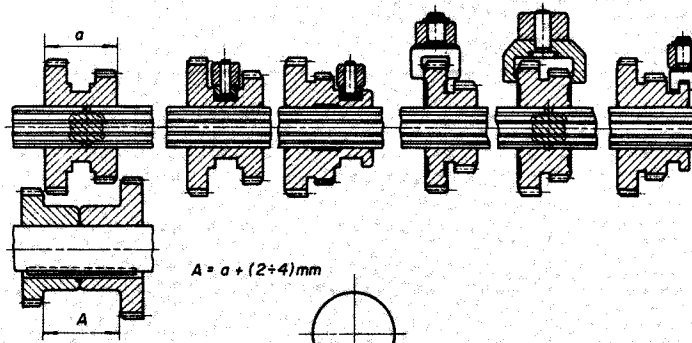
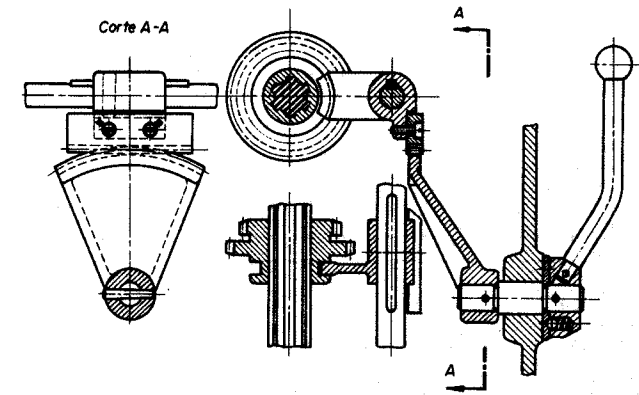

3 MARCHAS

$A = a + (2+4)mm$
 $B = b + (1+2)mm$
 $C = c + (2+4)mm$

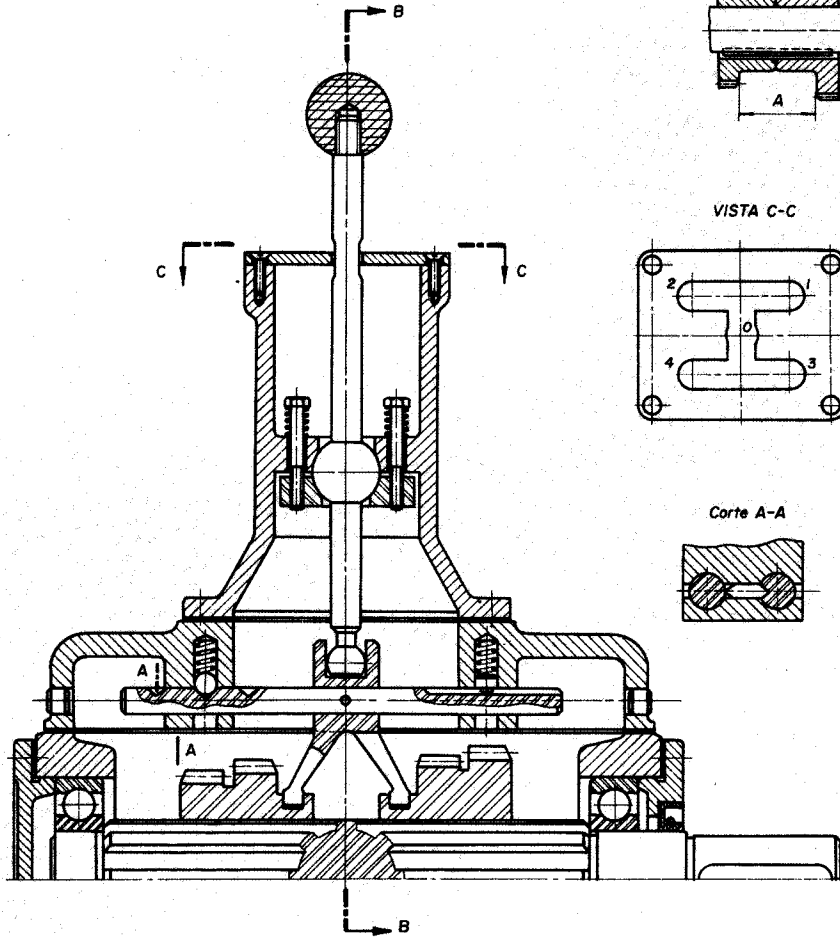
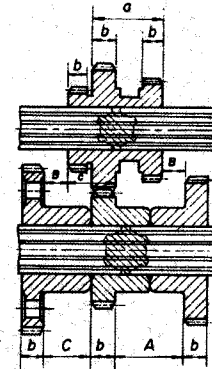

VISTA C-C

Corte A-A

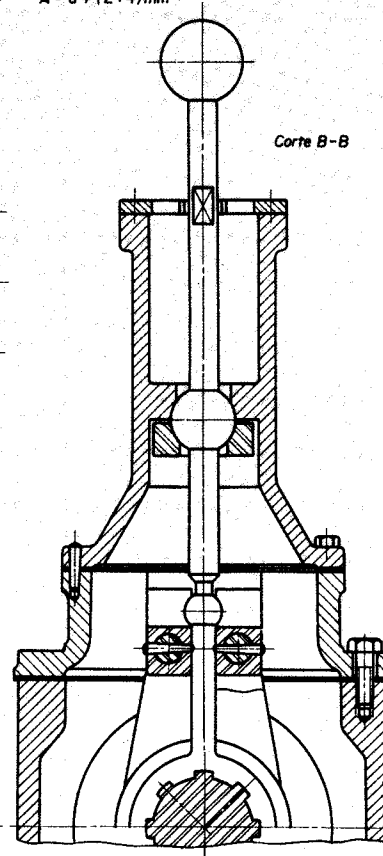

4 MARCHAS

$A = a + (1+2)mm$
 $B = b + (1+2)mm$
 $C = c + (2+4)mm$
 $E = e + (2+4)mm$

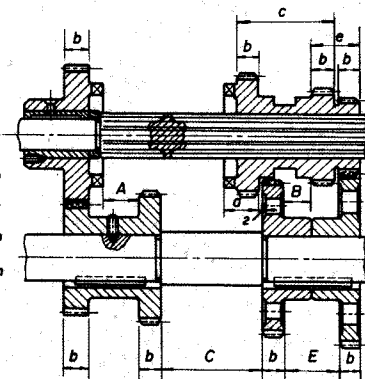

4 MARCHAS

$A = a + (2+4)mm$
 $B = b + (1+2)mm$
 $C = c - 2mm$
 $E = e + (2+4)mm$

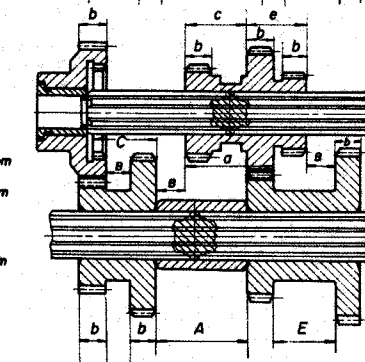

ODONTÓGRAFO DE GRANT

PARA TRAÇADO APROXIMADO DE PERFIS A EVOLVENTE

Nº DE DENTES	COEFICIENTES	
	f	f'
8	2,10	0,45
10	2,28	0,69
11	2,40	0,83
12	2,51	0,96
13	2,62	1,09
14	2,72	1,22
15	2,82	1,34
16	2,92	1,46
17	3,02	1,58
18	3,12	1,69
19	3,22	1,79
20	3,32	1,89
21	3,41	1,98
22	3,49	2,06
23	3,57	2,15
24	3,64	2,24
25	3,71	2,33
26	3,78	2,42
27	3,85	2,50
28	3,92	2,59
29	3,99	2,67
30	4,06	2,76
32	4,20	2,93
33	4,27	3,01
34	4,33	3,09
35	4,39	3,16
36	4,45	3,23
37-40	4,20	
41-45	4,63	
46-51	5,06	
52-60	5,74	
61-70	6,52	
71-90	7,72	
91-120	7,78	
121-180	13,38	
181-360	21,62	

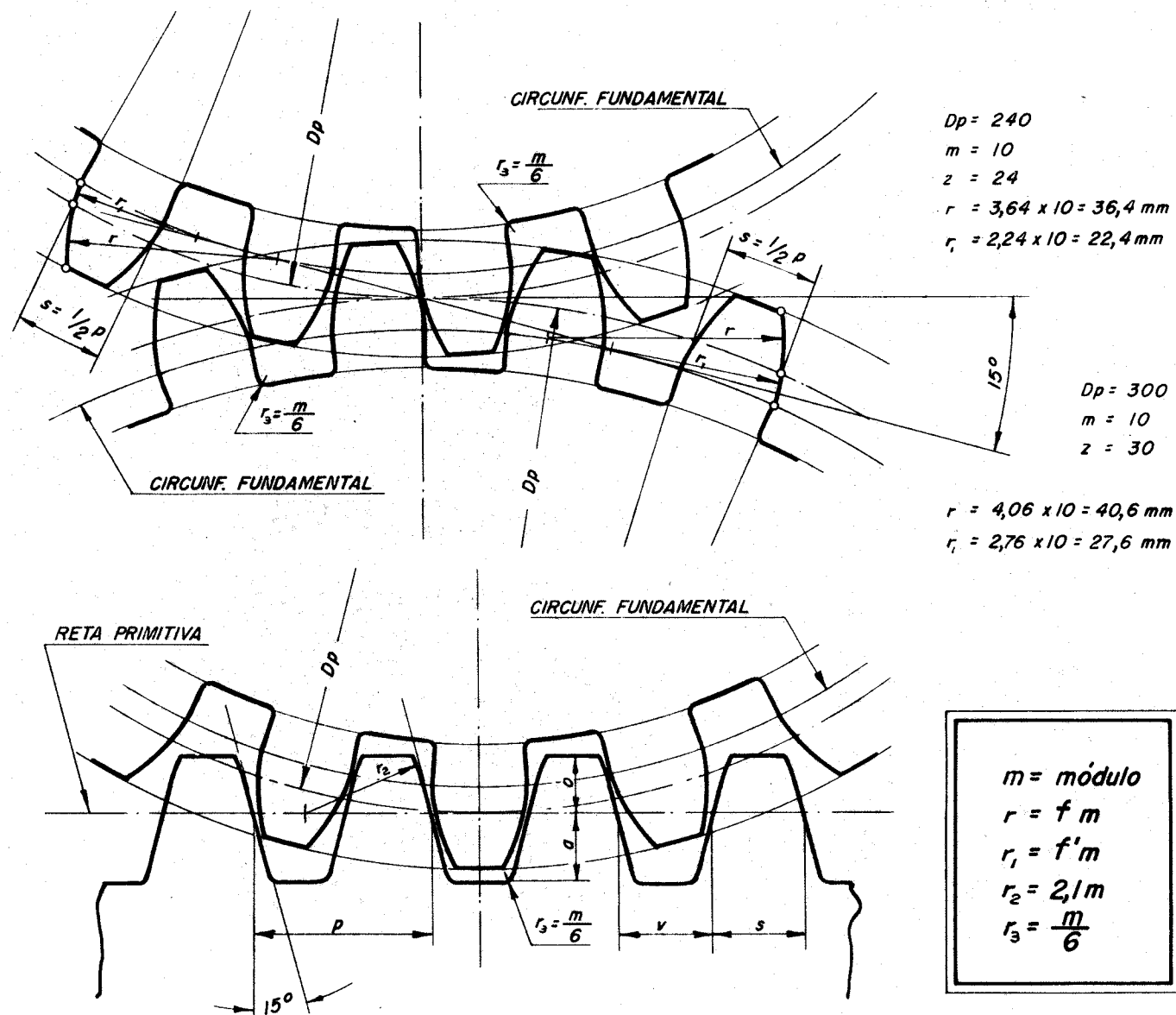

ENGRENAMENTOS A CICLÓIDES

LEI DO ENGRENAMENTO

As superfícies de engrenamento deverão apresentar normal comum no ponto de contacto.

ENGRENAMENTO EXTERNO

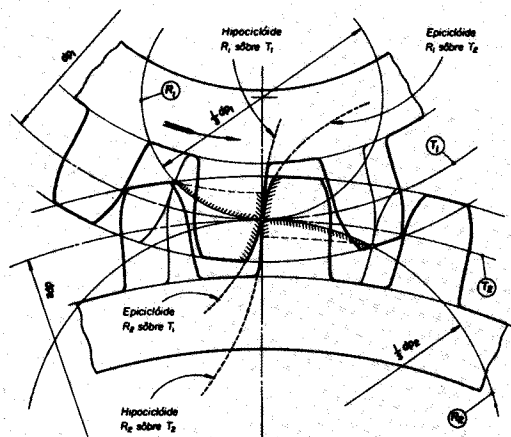

ENGRENAMENTO INTERNO

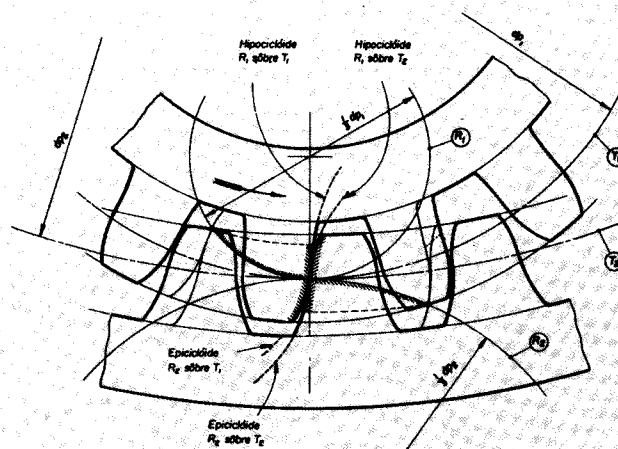

ENGRENAGEM E CREMALHEIRA

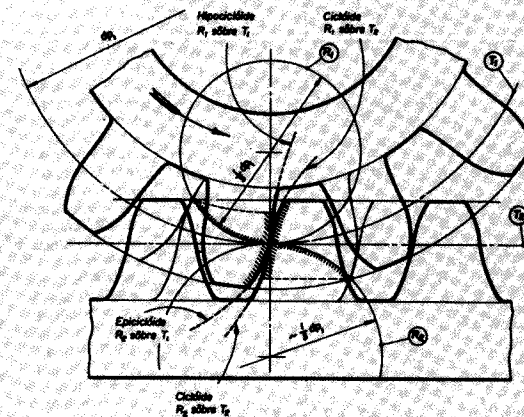

ENGRENAMENTOS A EVOLVENTES

ENGRENAMENTO EXTERNO

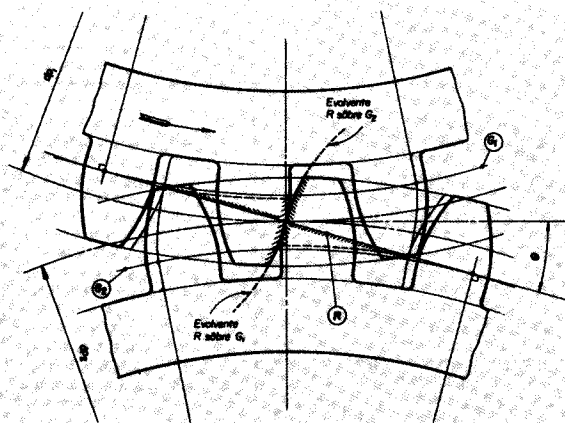

ENGRENAMENTO INTERNO

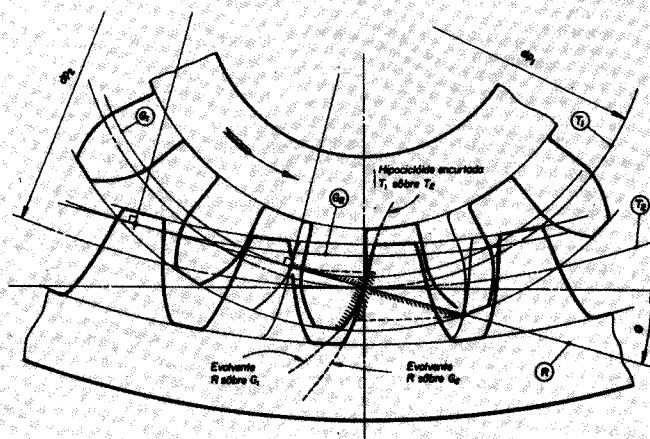

ENGRENAGEM E CREMALHEIRA

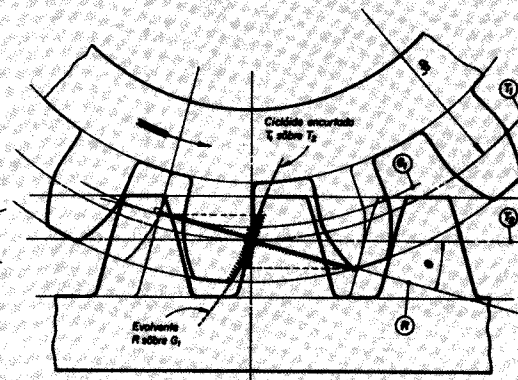

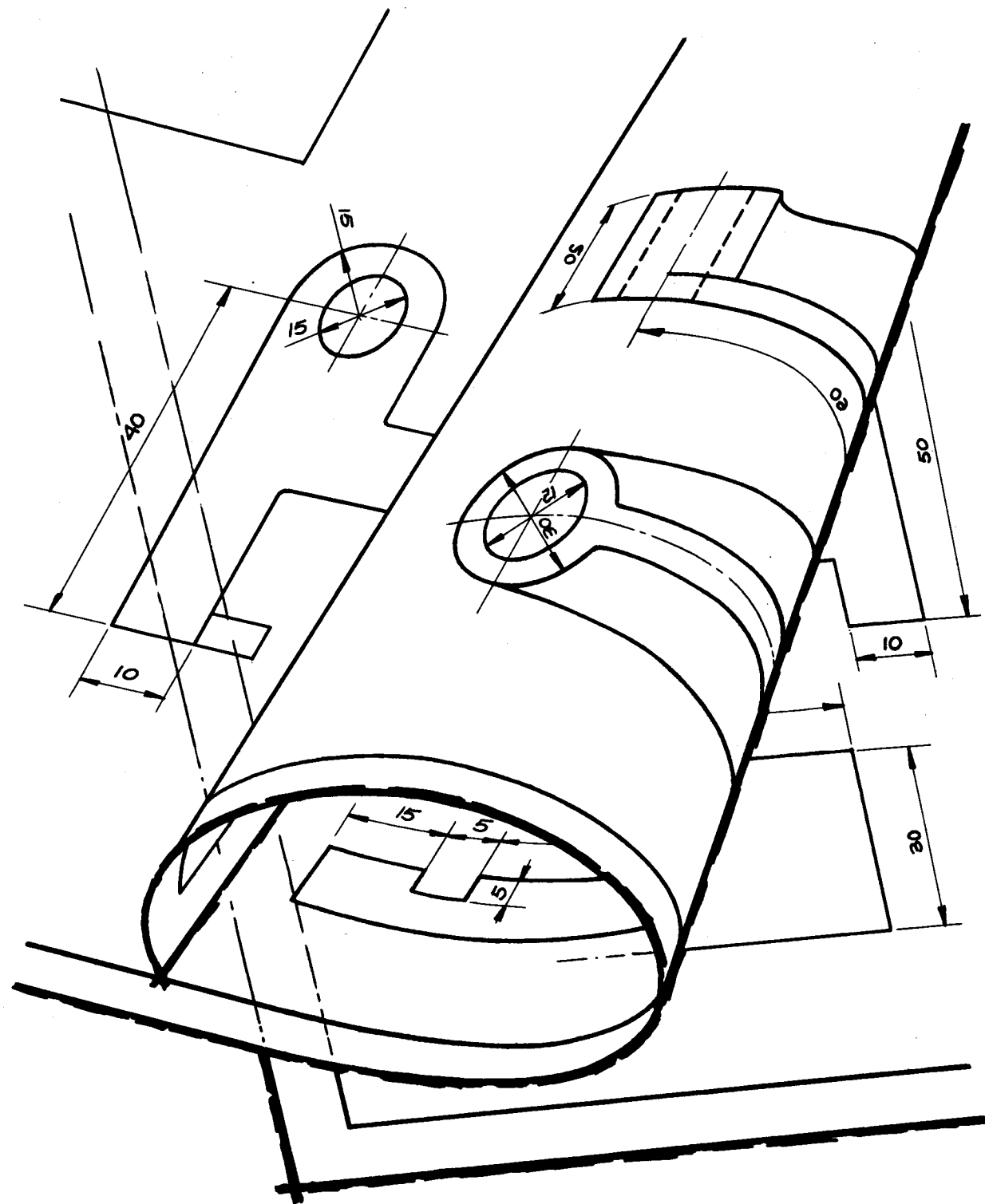

7

conjuntos e detalhes

ferramentas
de oficina
máquinas
hidráulicas
peças
de motor
correias
aplicações de
rolamentos
estruturas
máquinas
operatrizes
layout
isométrico
ferramentas



DISPOSITIVO DE FURAR ANÉIS

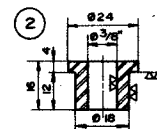
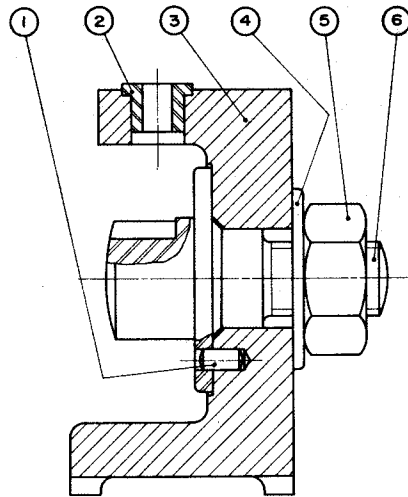
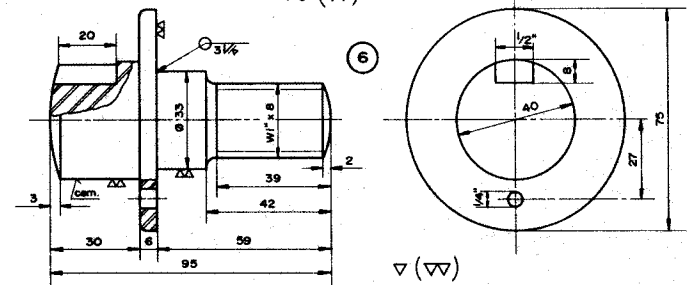
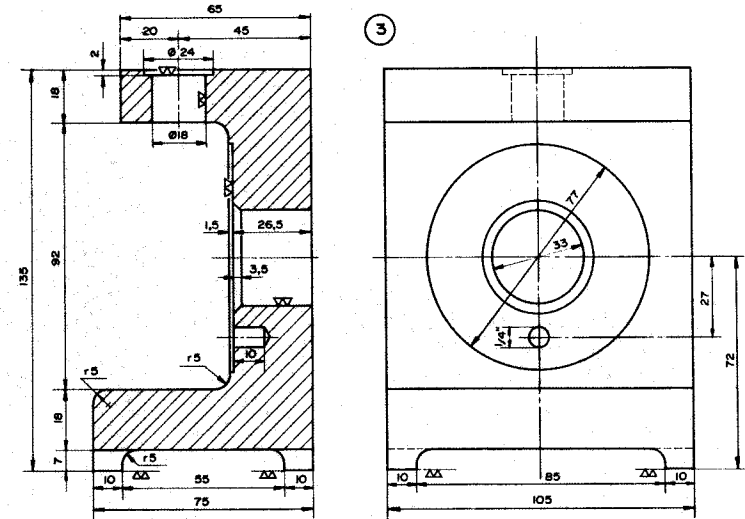
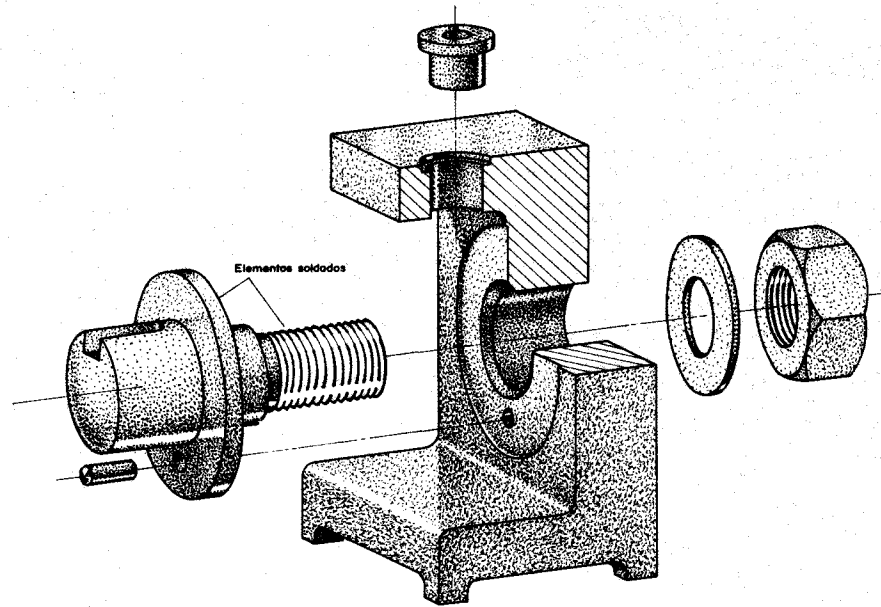

Nº	DENOMINAÇÕES	Quant.	MATERIAL E DIMENSÕES
6	Eixo	1	Aço NB 1030 Ø75 x 95
5	Porca sextavada	1	Aço NB 1020 Ø1"
4	Arruela	1	Aço NB 1020 Ø26
3	Suporte	1	Aço fundido 3525 AF
2	Bucha	1	Aço NB 1030 Ø24 x 16 lamp. cam.
1	Pino cilíndrico	1	Aço prata Ø 1/4" x 15

TORNINHO DE MECÂNICO

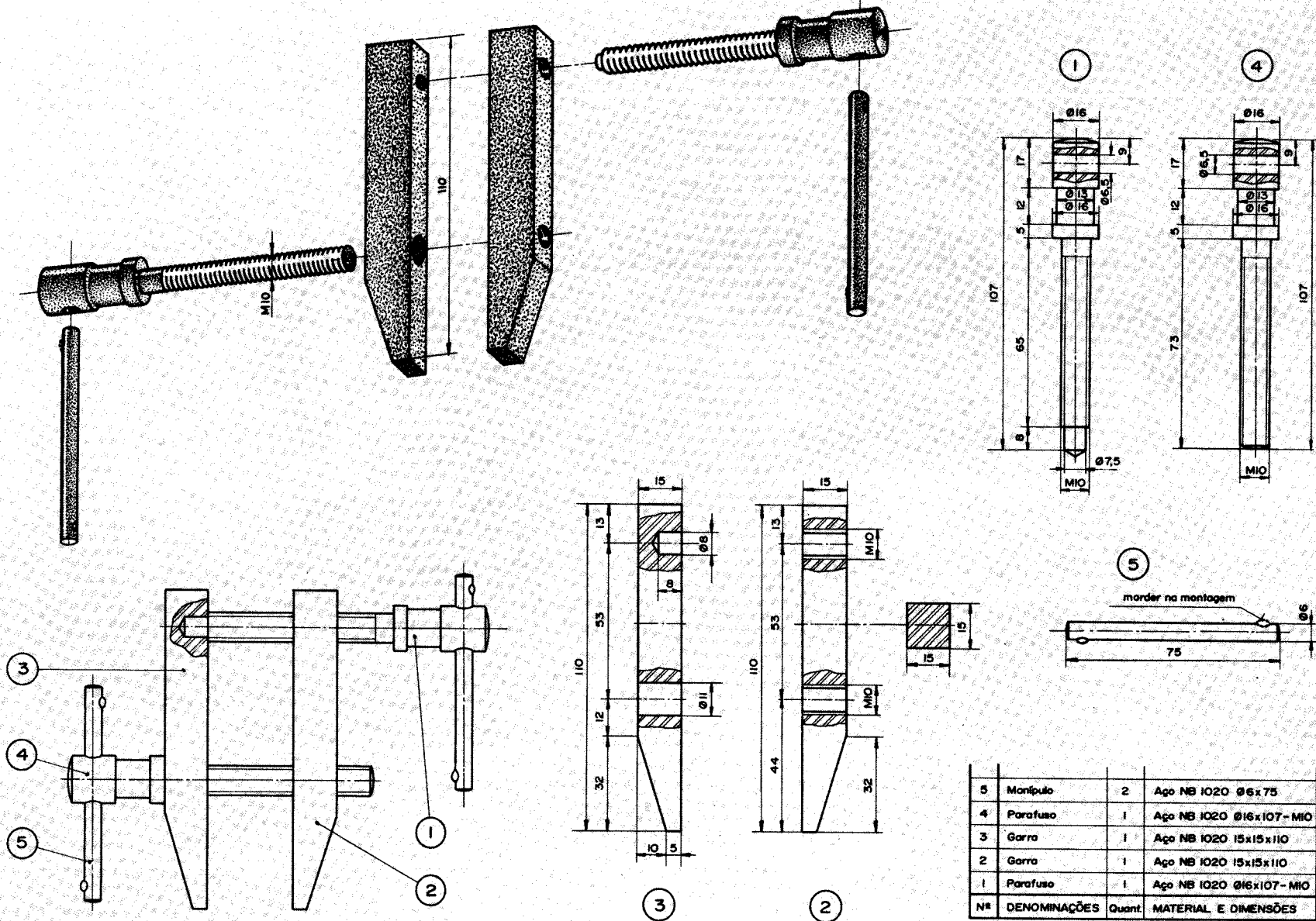

Nº	DENOMINAÇÕES	Quant.	MATERIAL E DIMENSÕES
5	Manípulo	2	Aço NB 1020 $\phi 6 \times 75$
4	Parafuso	1	Aço NB 1020 $\phi 16 \times 107$ -M10
3	Garra	1	Aço NB 1020 15x15x110
2	Garra	1	Aço NB 1020 15x15x110
1	Parafuso	1	Aço NB 1020 $\phi 16 \times 107$ -M10

TORNINHO PARALELO

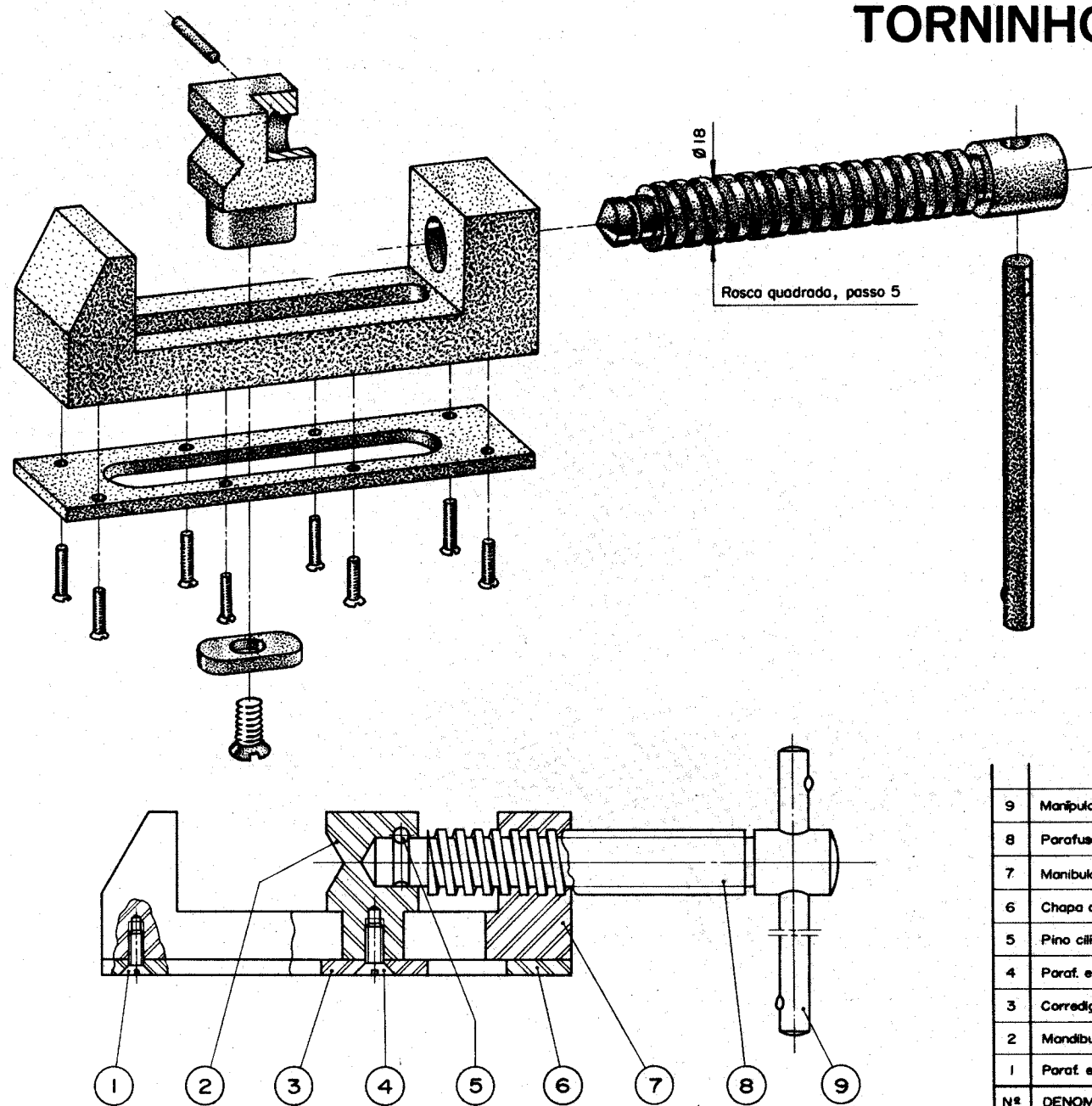

9	Manípulo	1	Aço NB 1020 Ø8x100
8	Parafuso	1	Aço NB 1030 Ø18x132
7	Maníbula fixa	1	Aço NB 1020 40x40x130
6	Chapa de guia	1	Aço NB 1020 40x130x4
5	Pino cilíndrico	1	Aço prata Ø 4x40
4	Paraf. escareado	1	Ø 5/16" x 14
3	Corrediça	1	Aço NB 1020 18x28x4
2	Mandíbula móvel	1	Aço NB 1020 40x40x26
1	Paraf. escareado	8	Ø 1/8" x 12
Nº	DENOMINAÇÕES	Quant.	MATERIAL E DIMENSÕES

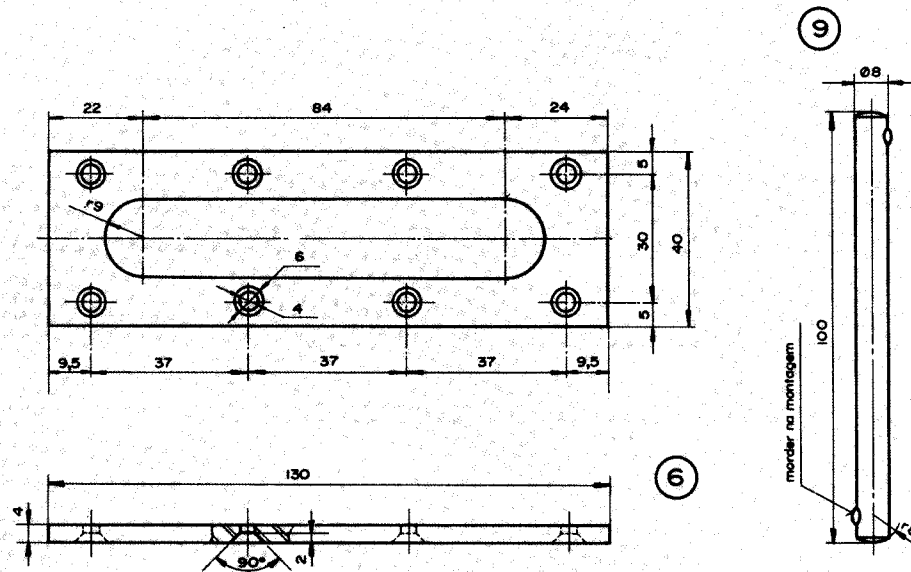
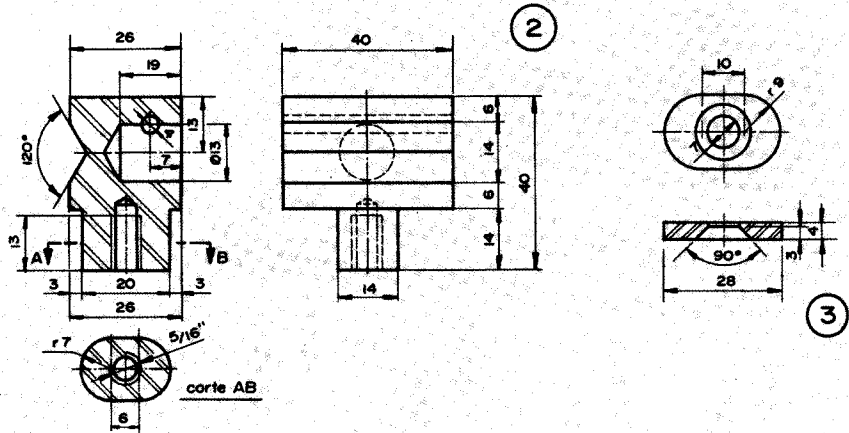
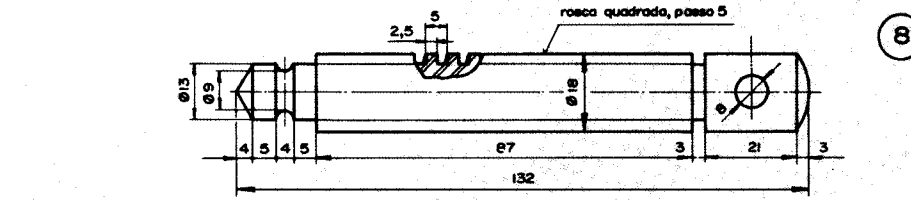
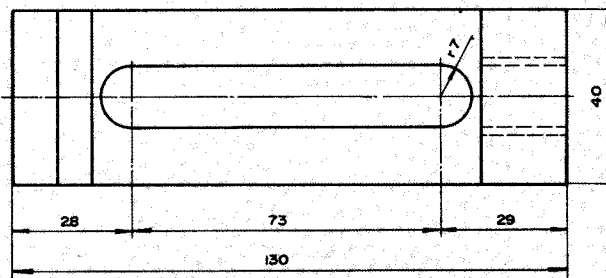
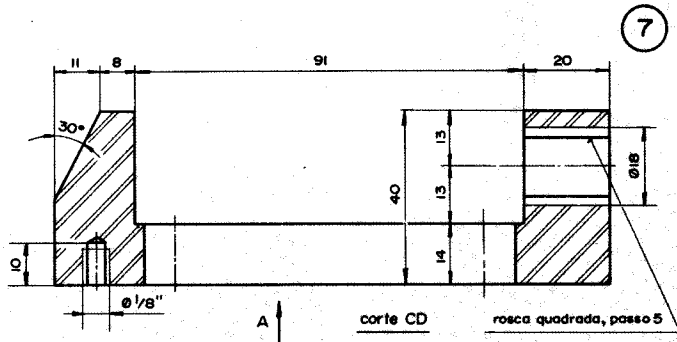
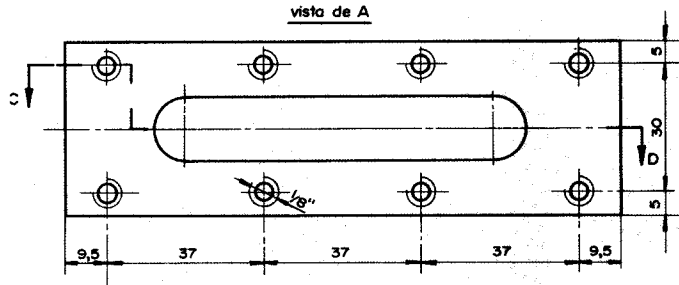

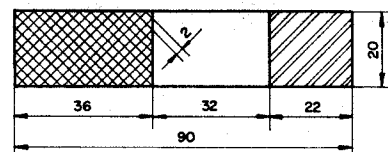
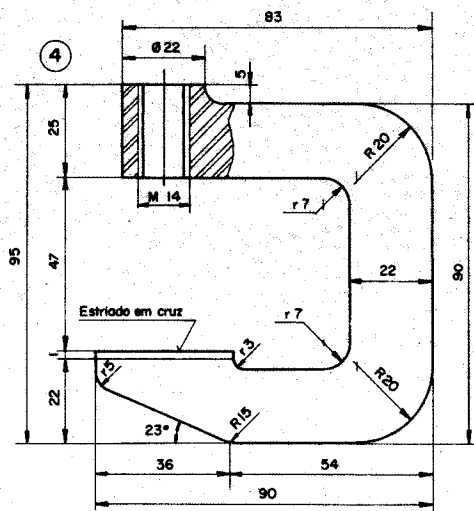
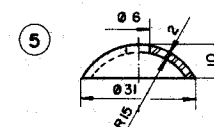
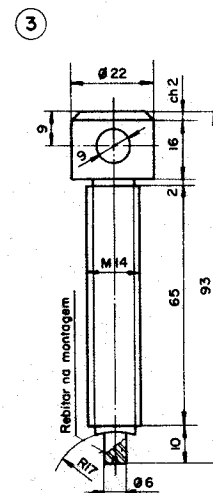
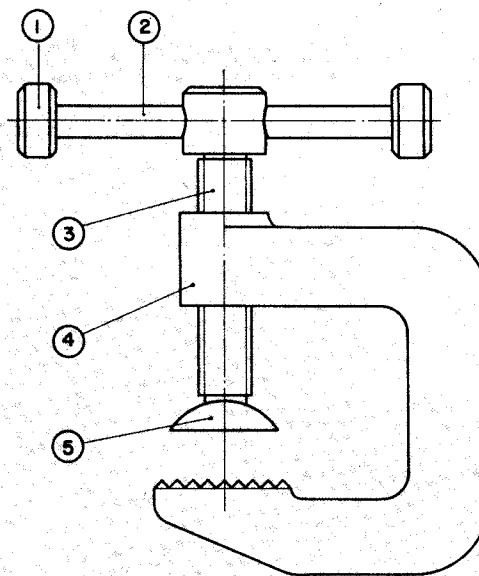
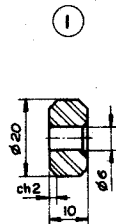
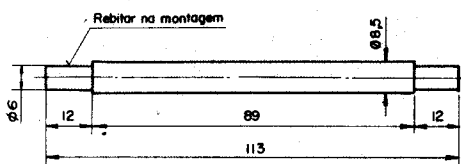
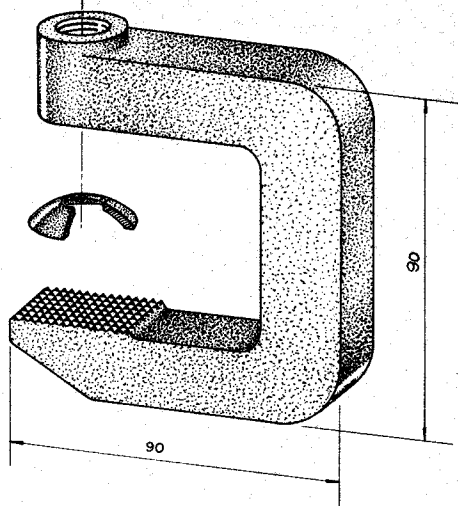
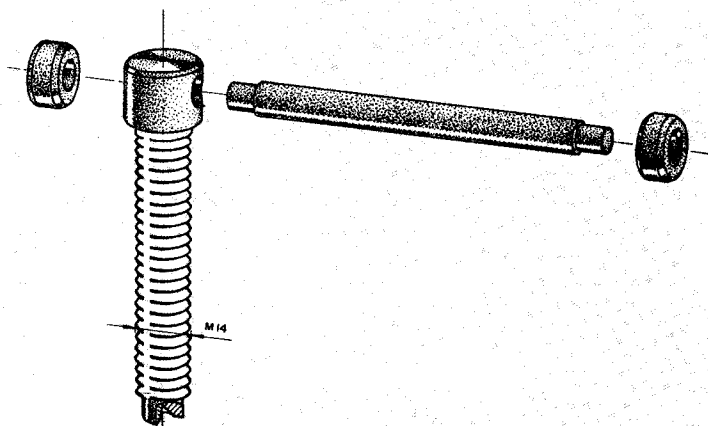

GRAMPO

Nº	DENOMINAÇÕES	Quant.	MATERIAL E DIMENSÕES
5	Mordente	1	Aço NB 1020
4	Corpo	1	Aço forjado NB 1020
3	Parafuso	1	Aço NB 1020 Ø22x93-M14
2	Manipulo	1	Aço NB 1020 Ø8,5x113
1	Encosto	2	Aço NB 1020 Ø20x10

GRAMPO DE AÇÃO RÁPIDA

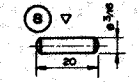
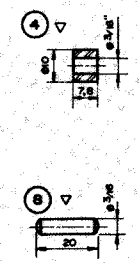
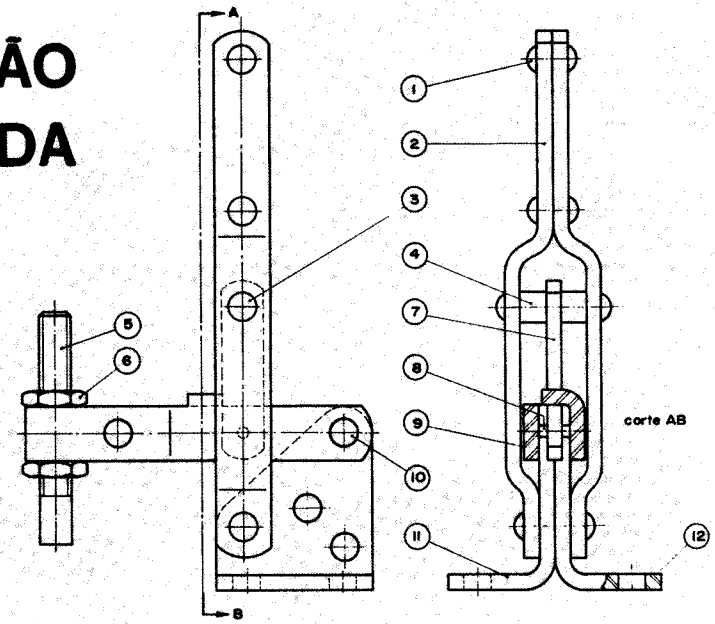
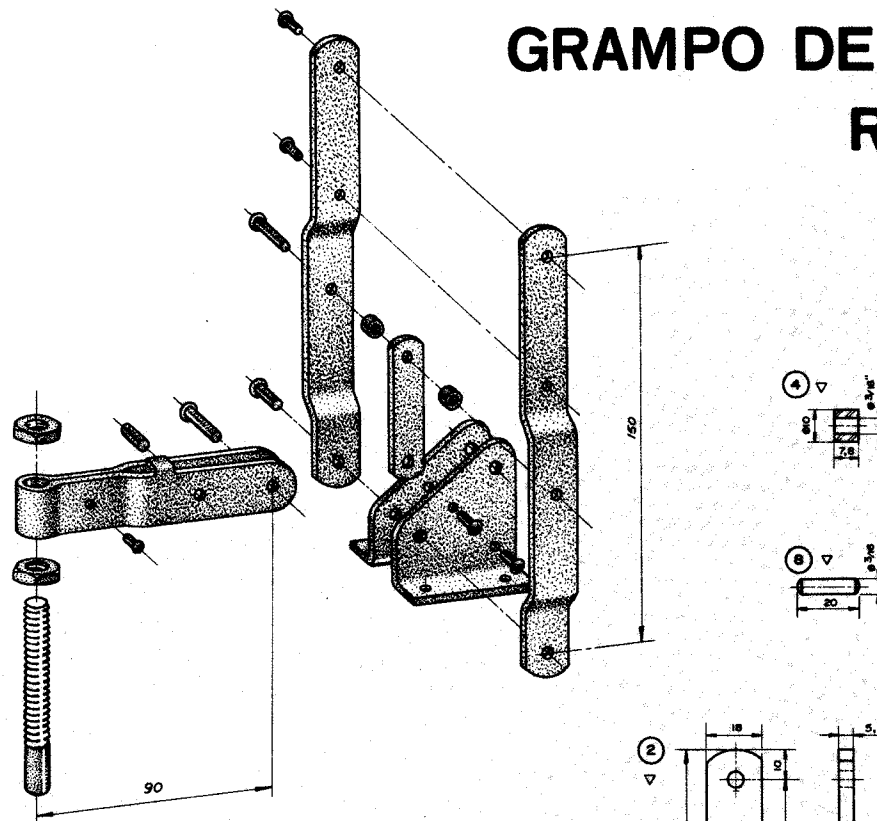

11 Igual à peça nº 12 porém dobrada à esquerda.

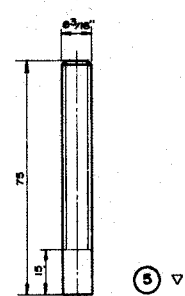
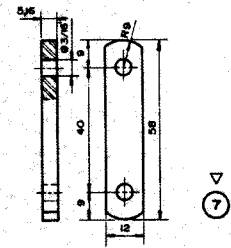
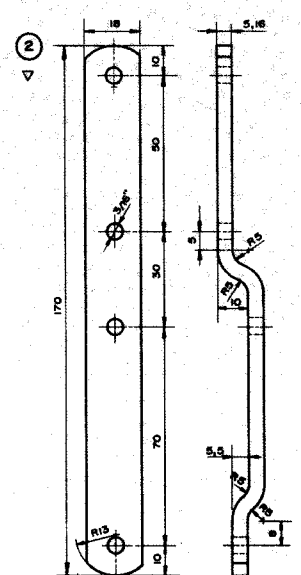
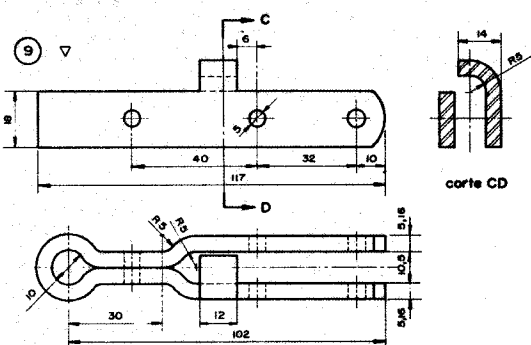
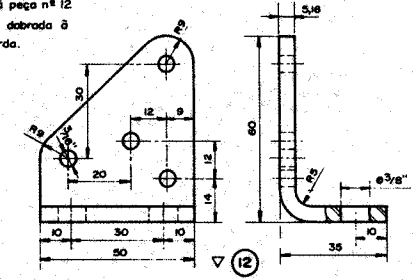

Nº	DENOMINAÇÕES	Quant.	MATERIAL E DIMENSÕES
12	Base direita	1	Aço NB 1020 Chapa 6G # 6
11	Base esquerda	1	Aço NB 1020 Chapa 6G # 6
10	Rabite	2	Aço NB 1010 Ø 3/16" x 1 1/8"
9	Travessa	1	Aço NB 1020 Chapa 6G # 6
8	Pino	1	Aço NB 1040 Ø 3/16" x 20
7	Trava	1	Aço NB 1020 Chapa 6G # 6
6	Parca sextavada	2	Aço NB 1020 Ø 3/16"
5	Fixador	1	Aço NB 1020 Ø 3/16" x 75
4	Distanciador	2	Aço NB 1020 Ø 10 x 7,8
3	Rabite	1	Aço NB 1010 Ø 3/16" x 1 1/2"
2	Alavanca	2	Aço NB 1020 Chapa 6G # 6
1	Rabite	5	Aço NB 1010 Ø 3/16" x 1 1/16"

EXTRATOR

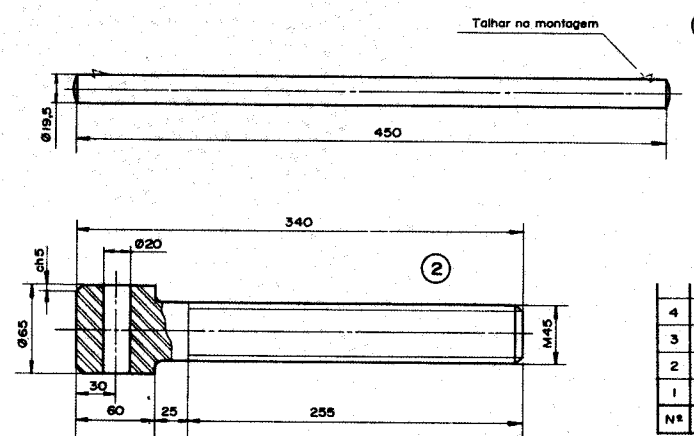
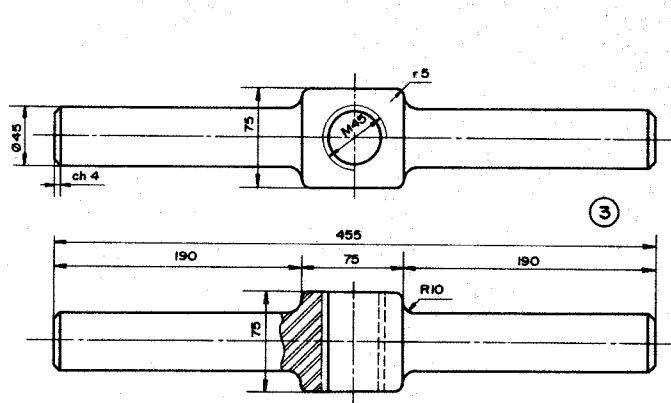
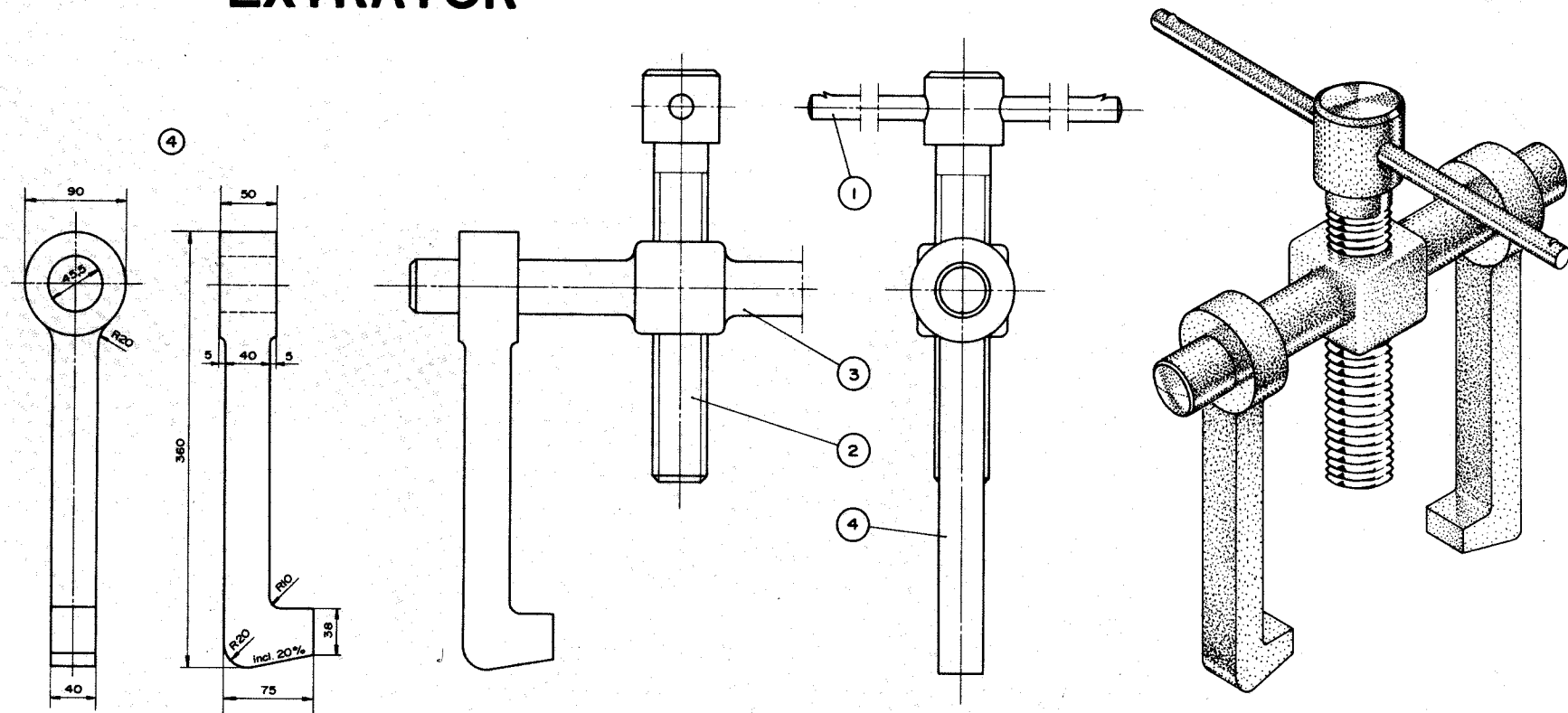

Nº	DENOMINAÇÕES	Quant.	MATERIAL E DIMENSÕES
4	Garra	2	Aço NB 1020 Forjado
3	Travessa	1	Aço NB 1020 Forjado
2	Parafuso	1	Aço NB 1020 Ø65x340-M45
1	Manípulo	1	Aço NB 1020 Ø19,5 x 450

EXTRATOR

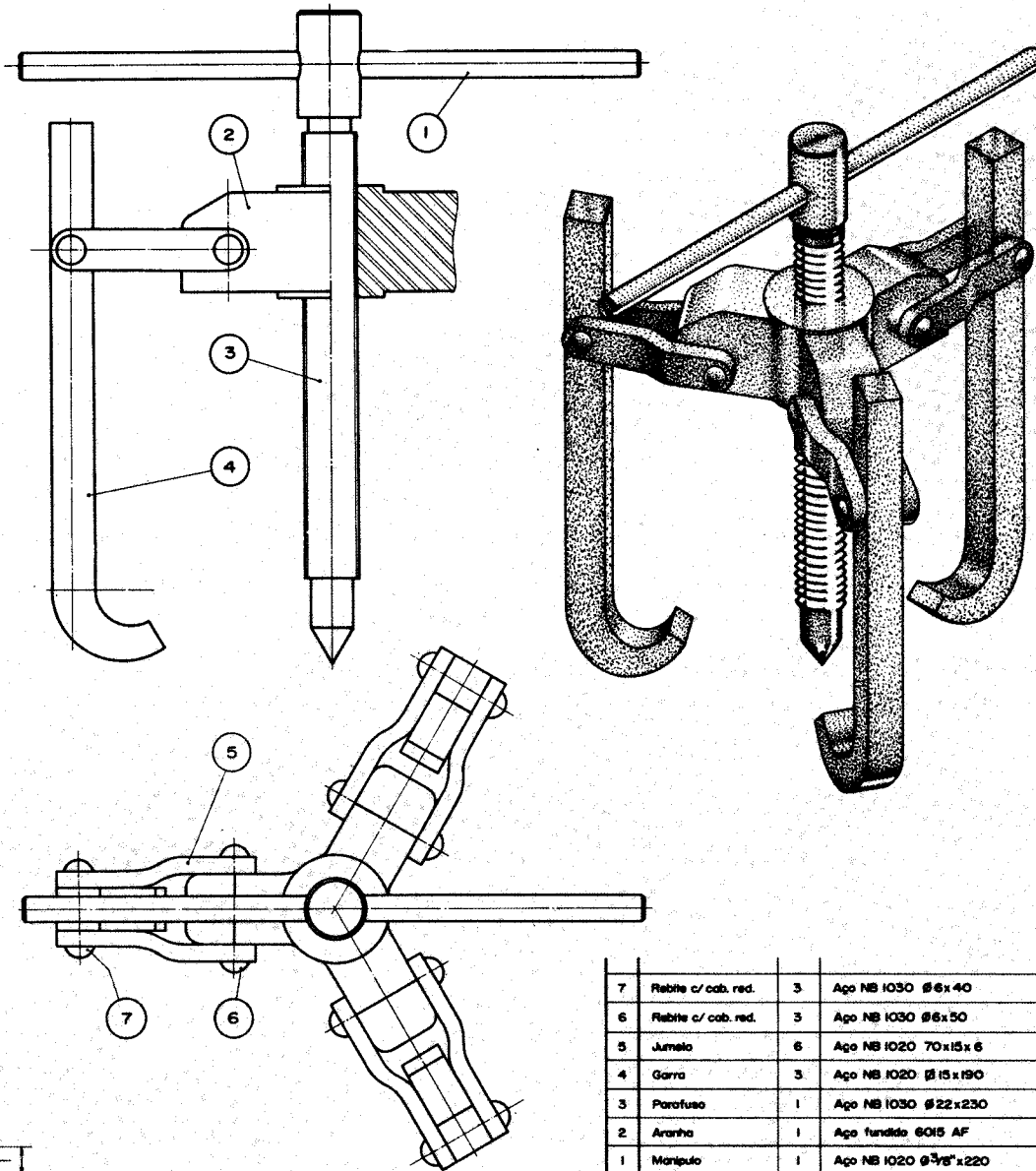
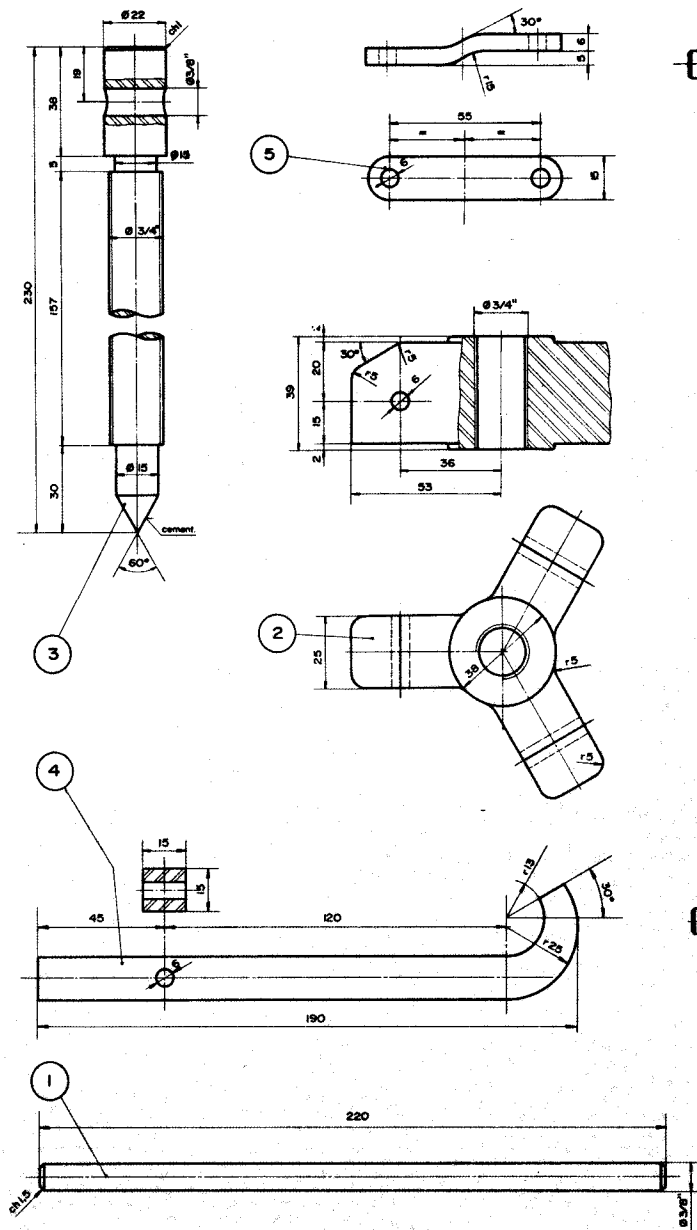

7	Rebite c/ cob. red.	3	Aço NB 1030 Ø6x40
6	Rebite c/ cob. red.	3	Aço NB 1030 Ø6x50
5	Jumela	6	Aço NB 1020 70x15x6
4	Garra	3	Aço NB 1020 Ø15x190
3	Parafuso	1	Aço NB 1030 Ø22x230
2	Aranha	1	Aço fundido 6015 AF
1	Manipulo	1	Aço NB 1020 Ø3/8"x220
Nº	DENOMINAÇÕES	Quant.	MATERIAL E DIMENSÕES

MACACO

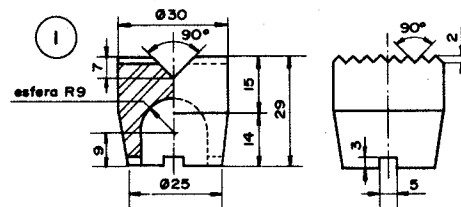
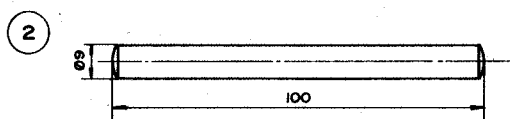
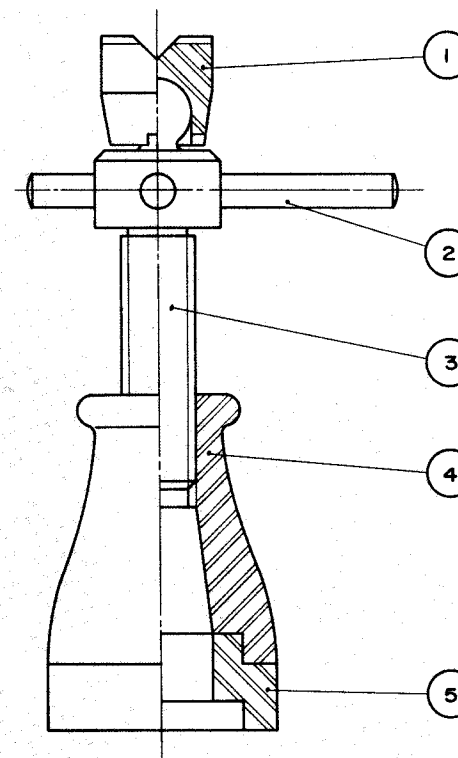
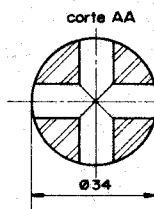
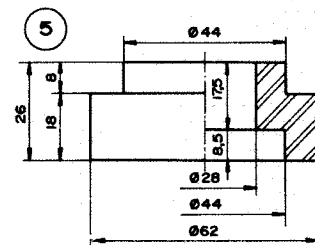
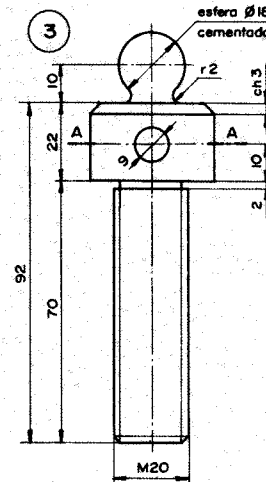
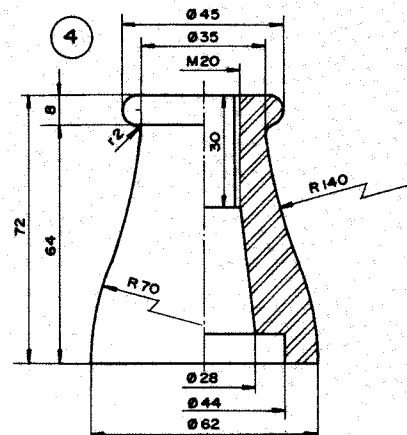
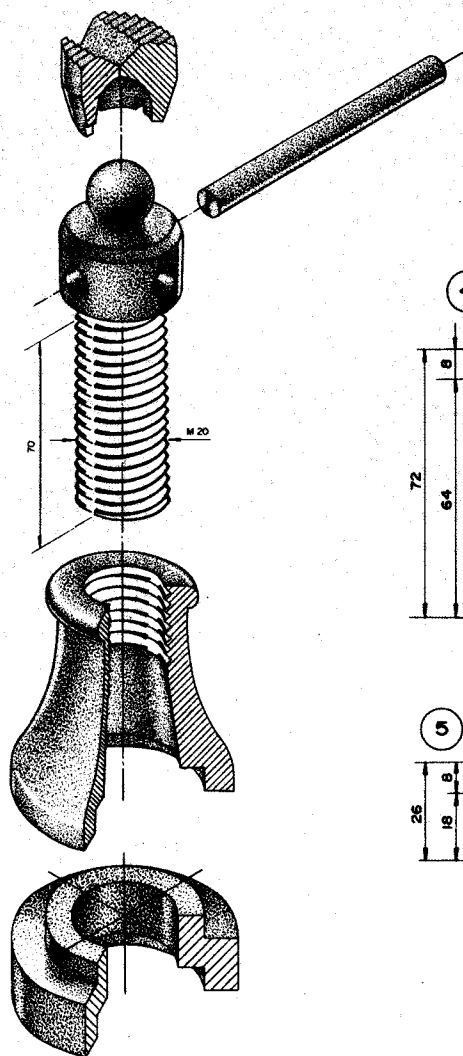

Nº	DENOMINAÇÕES	Quant.	MATERIAL E DIMENSÕES
5	Suplemento	1	Aço NB 1030 Ø62x26
4	Corpo	1	Aço NB 1030 Ø62x72
3	Parafuso	1	Aço NB 1030 Ø34x111
2	Manípulo	1	Aço NB 1020 Ø9x100
1	Chapéu	1	Aço NB 1030 Ø30x29 temp. cem.

ALAVANCA DE COMANDO

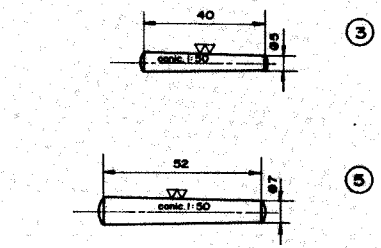
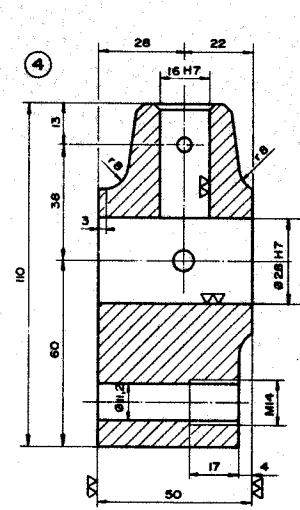
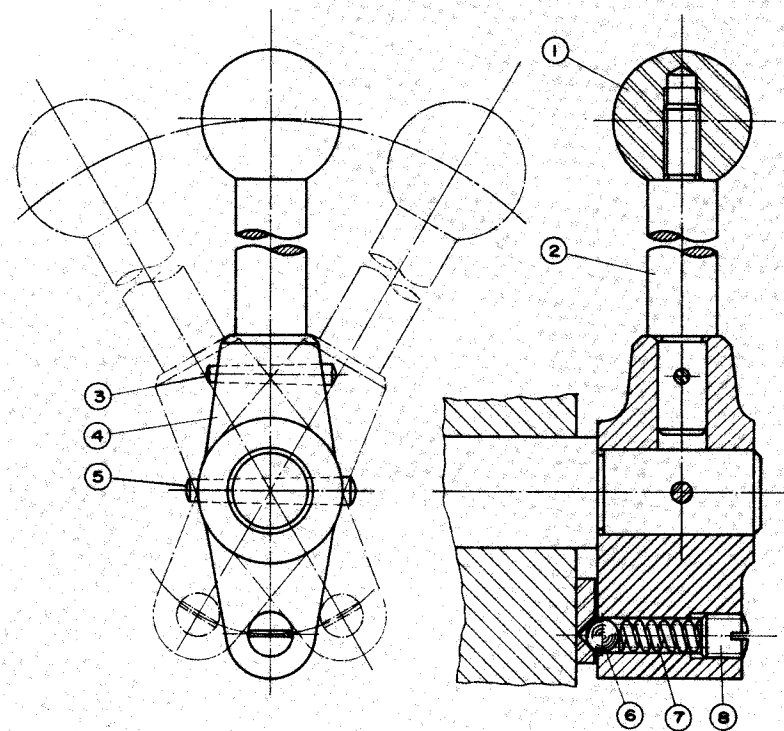
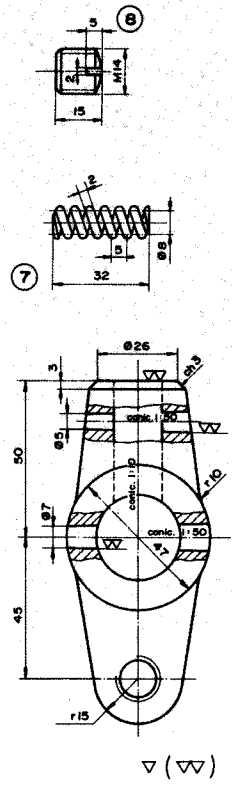
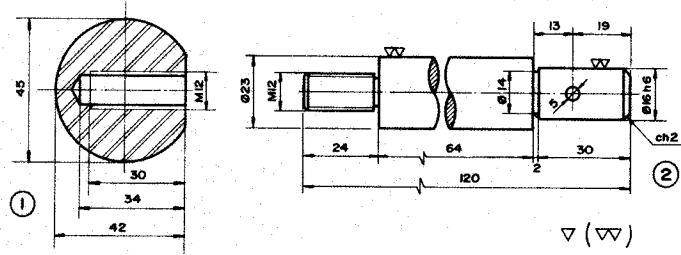
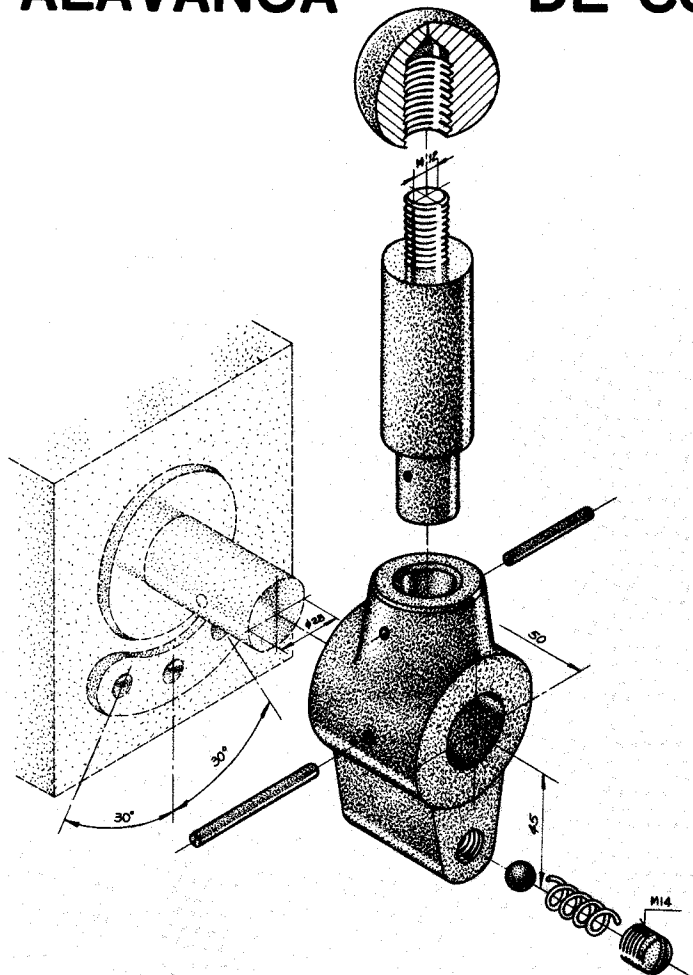

Nº	DENOMINAÇÕES	Quant.	MATERIAL E DIMENSÕES
8	Parafuso sem cob.	1	Aço 1020 M14 x 15
7	Mola	1	Aço NB 1070
6	Esfera	1	Aço forjado SFC- Ø 7/16"
5	Pino cônico	1	Aço preto Ø 5 x 40
4	Corpo	1	Ferro fundido
3	Pino cônico	1	Aço preto Ø 5 x 40
2	Alavanca	1	Aço NB 1020 - Ø 23 x 120
1	Esfera	1	Aço NB 1000 Ø 45

CHAVE DE GRIFO

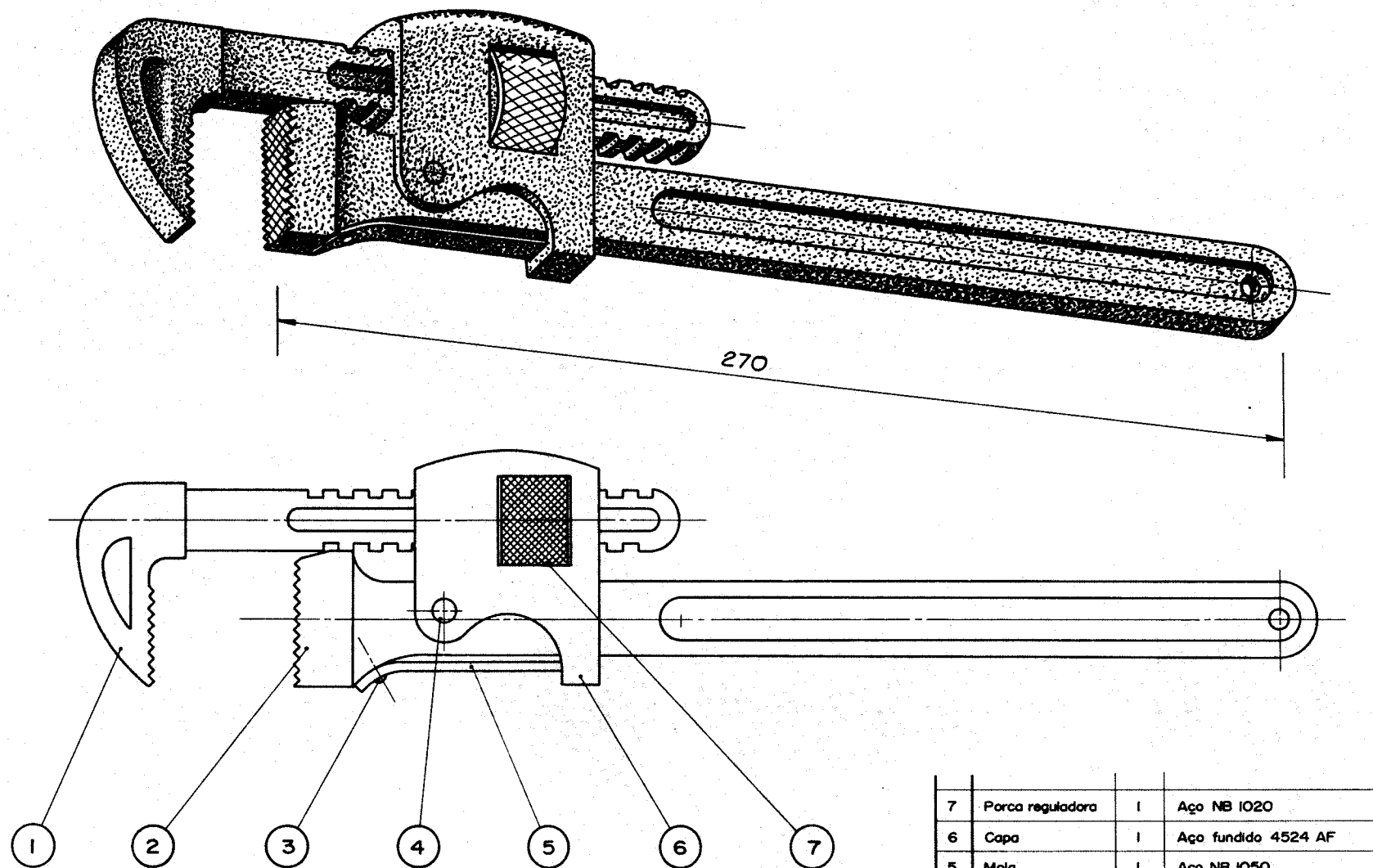

7	Porca reguladora	1	Aço NB 1020
6	Capa	1	Aço fundido 4524 AF
5	Mola	1	Aço NB 1050
4	Pino cônico	1	Aço NB 1050 Ø6x21
3	Paraf. cab. red.	1	Aço NB 1020 Ø 1/8" x 6
2	Mandíbula fixa	1	Aço forjado NB 1030
1	Mandíbula móvel	1	Aço forjado NB 1030
Nº	DENOMINAÇÕES	Quant.	MATERIAL E DIMENSÕES

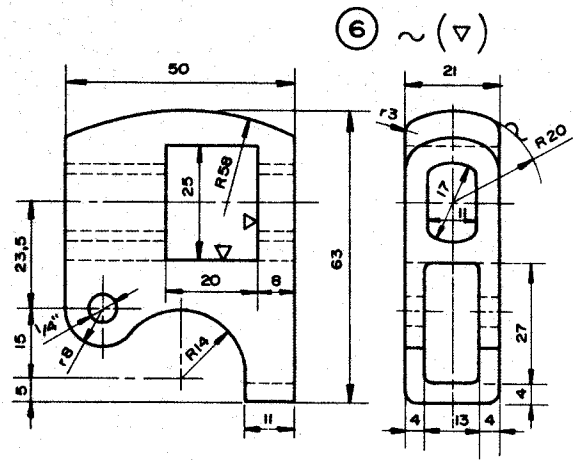
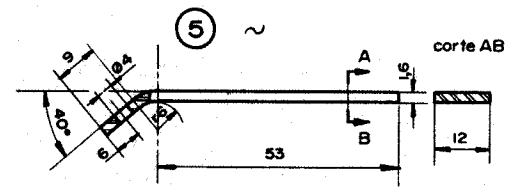
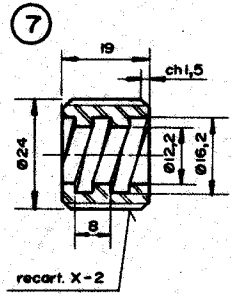
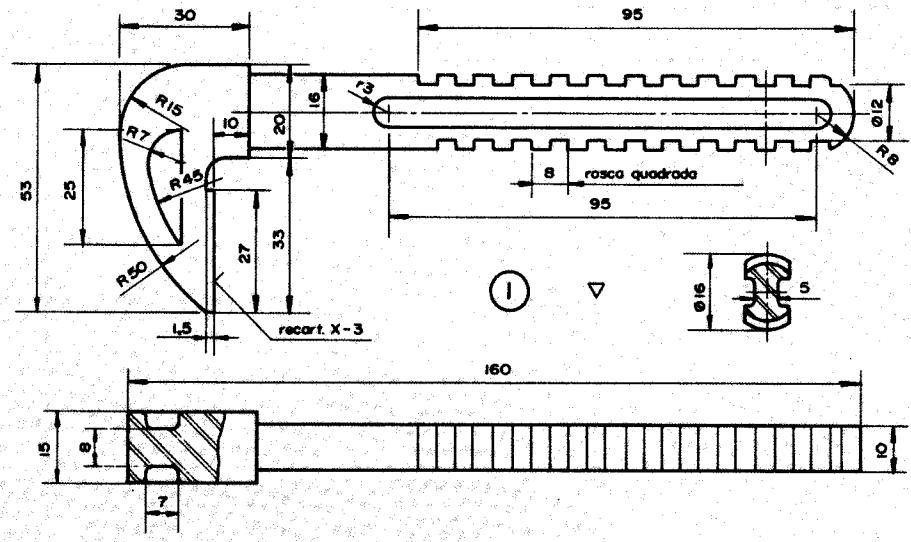
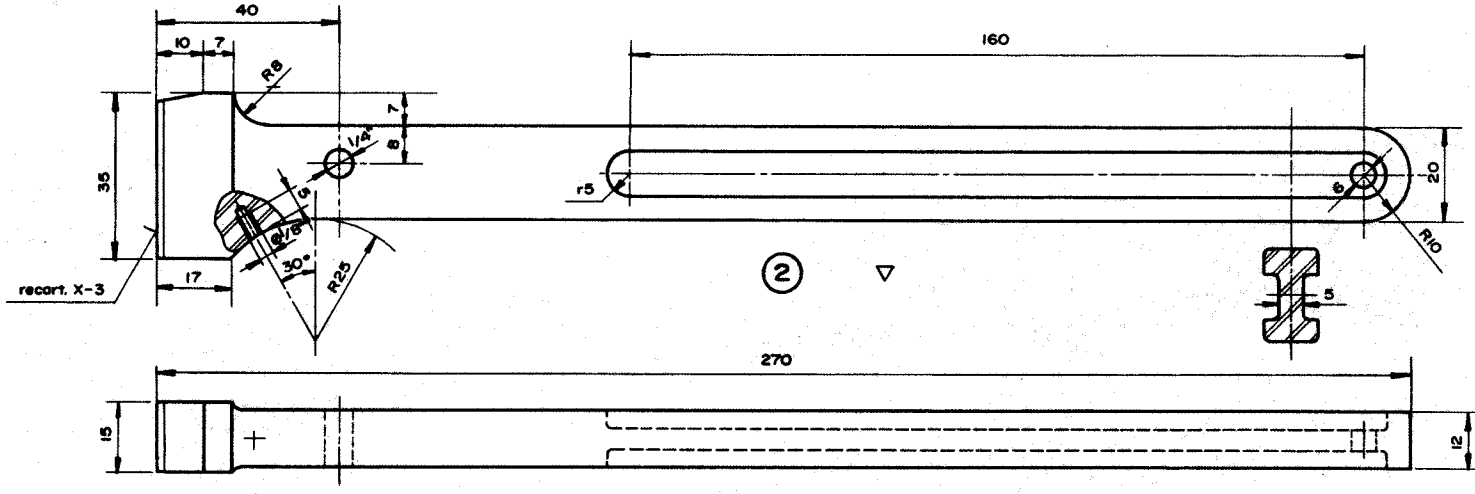

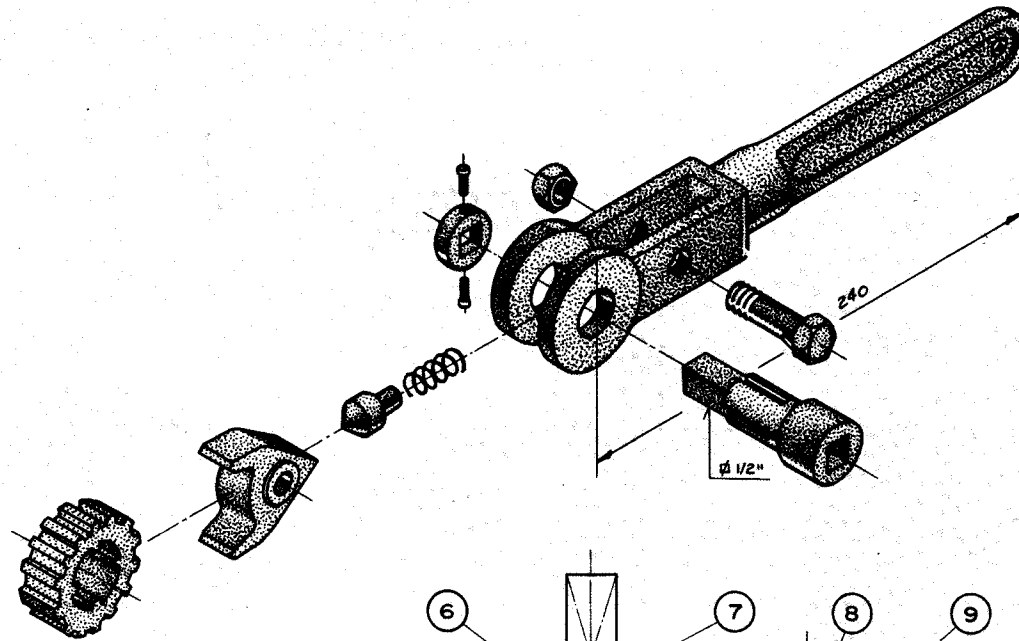

CHAVE ROQUETE

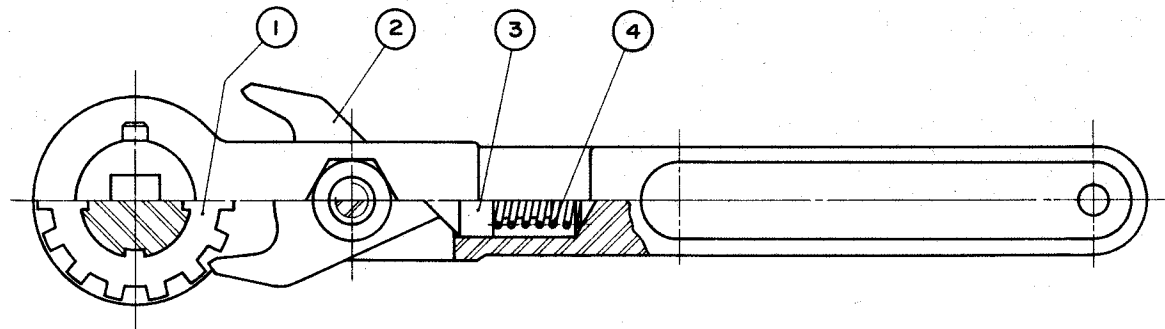
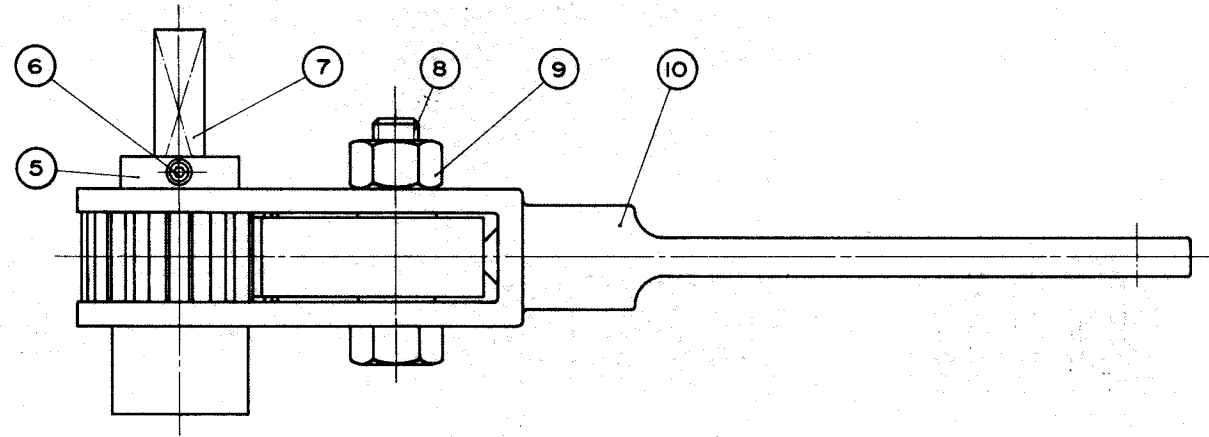

10	Braco	1	Aço fundido 3525 AF
9	Porca sext.	1	M12
8	Paraf. sext. c/nerv.	1	M12 x 52
7	Encaixe	1	Aço NB 1030 Temp. e cem.
6	Paraf. Allen	2	Ø 3/16" x 1/2"
5	Encosto	1	Aço NB 1020
4	Mola	1	Aço NB 1070
3	Trava	1	Aço NB 1020 Temp. e cem.
2	Tranqueta	1	Aço NB 1030 " "
1	Catraca	1	Aço NB 1030 " "
Nº	DENOMINAÇÕES	Quant.	MATERIAL E DIMENSÕES

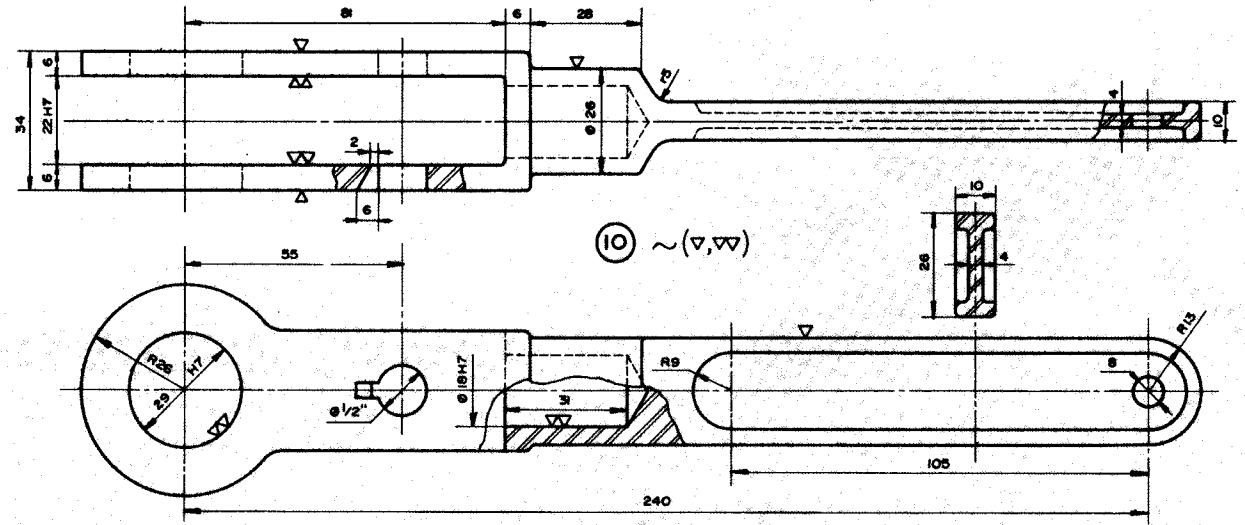

⑩ ~ (∇, ∇)

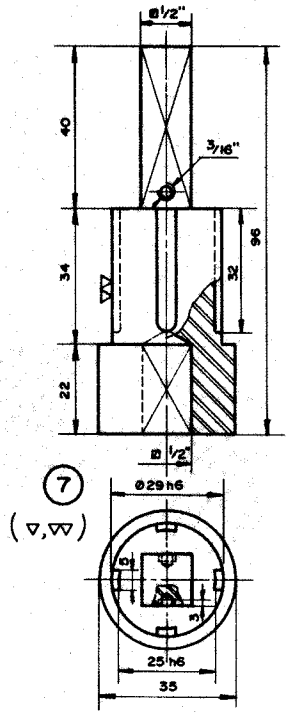

⑦ (∇, ∇)

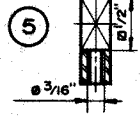
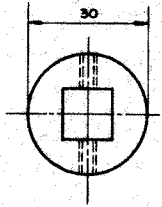
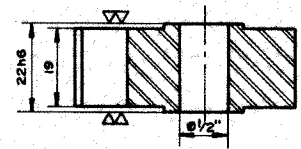
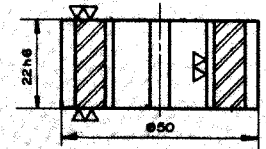

⑤

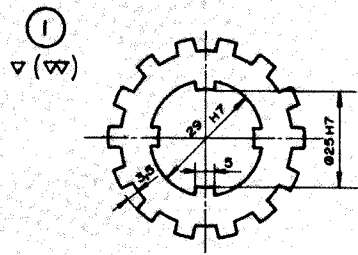

① (∇)

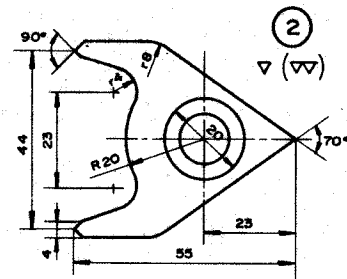

② (∇)

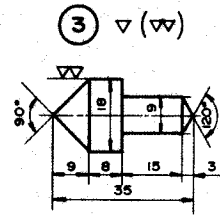

③ (∇)

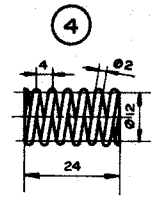

④

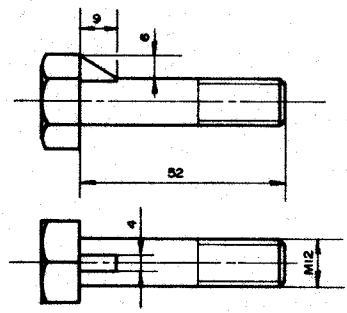

⑧

MORSA DE BANCADA

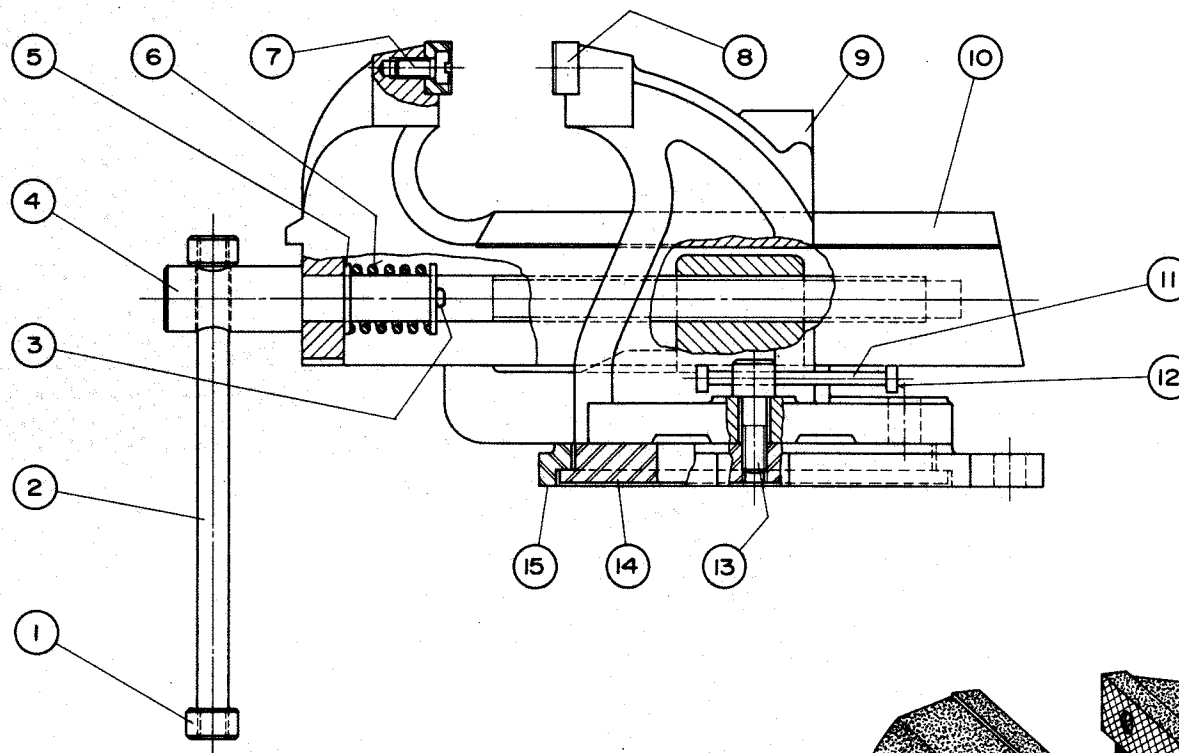

15	Suporte	1	Aço NB 1020 13x158x178
14	Placa	1	Aço NB 1020 12x 120
13	Parafuso	2	Aço NB 1020 Ø14 x 35
12	Encoito	4	Aço NB 1020 Ø8x 4
11	Brogo	2	Aço NB 1020 Ø4x63
10	Carro	1	Ferro fundido 230 x 98 x 84
9	Corpo	1	Ferro fundido 158x124x122
8	Mordente	1	Aço NB 1020 8x16x84
7	Paraf. cob. cilind.	4	Aço NB 1010 Ø1/4"x16
6	Placa seção circ.	1	Aço NB 1045 D=18, p=6, d=3
5	Arruela	2	Aço NB 1010 Ø15
4	Paraf. de aperto	1	Aço NB 1020 Ø20x248
3	Contrapino	1	Aço Ø3x22
2	Brego	1	Aço NB 1020 Ø9x154
1	Encoito	2	Aço NB 1020 Ø15x9
Nº	DENOMINAÇÕES	Quant.	MATERIAL E DIMENSÕES

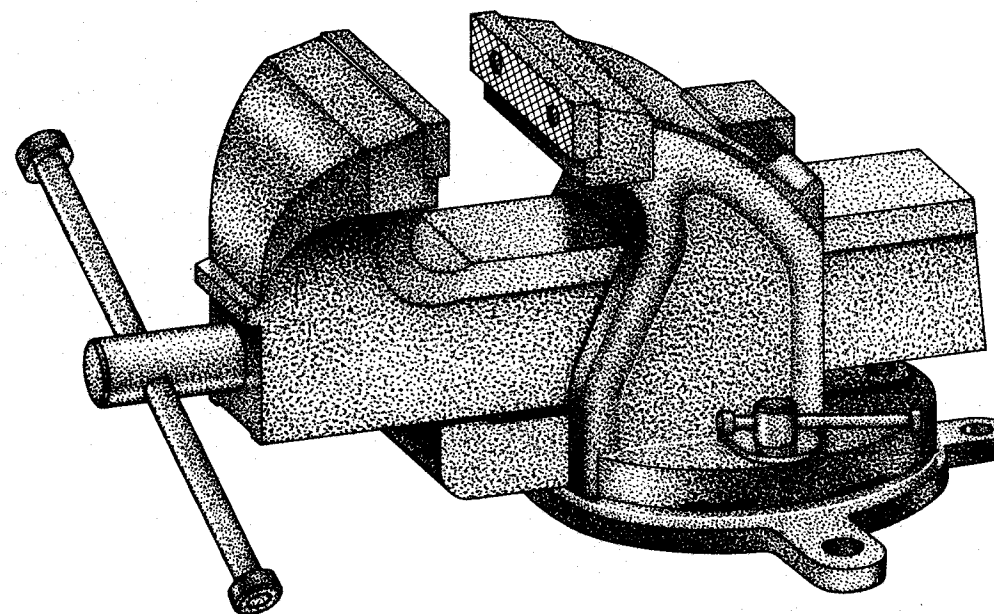

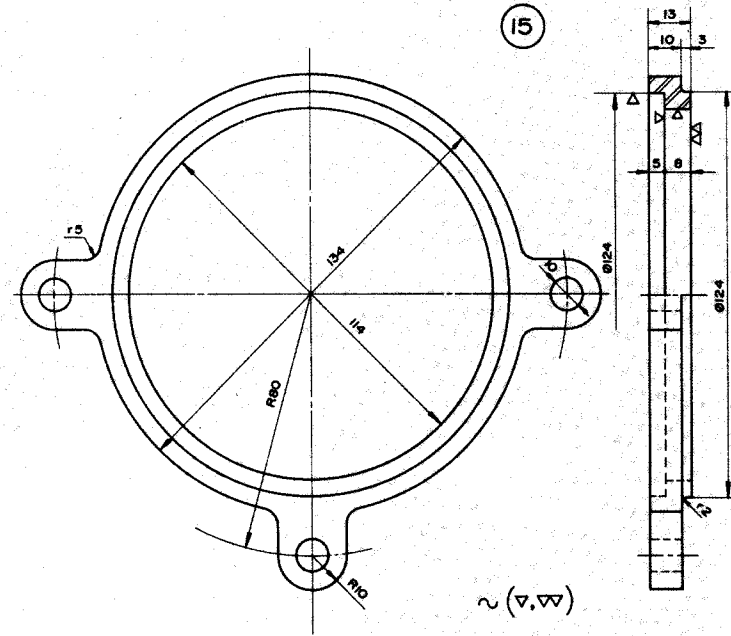
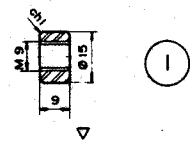
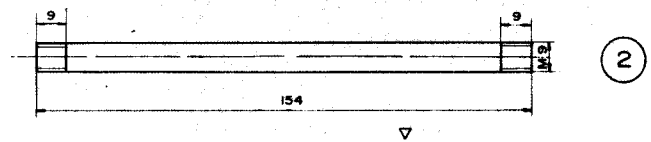
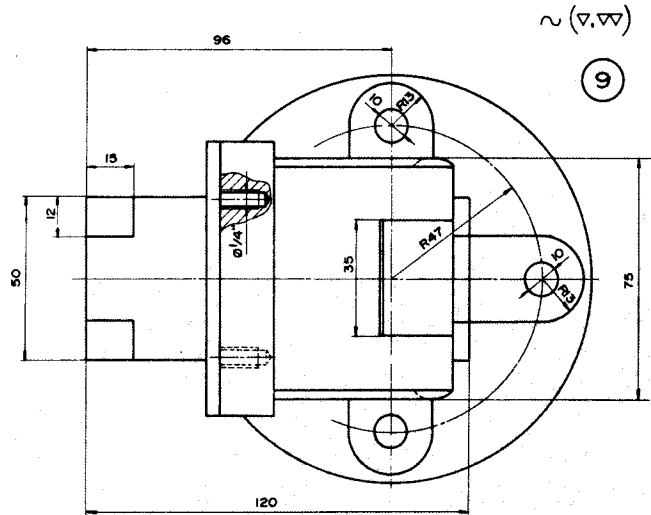
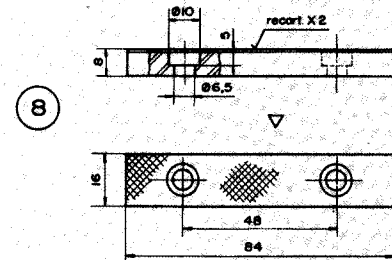
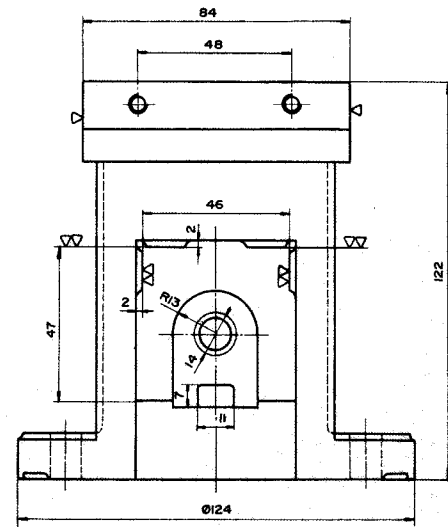
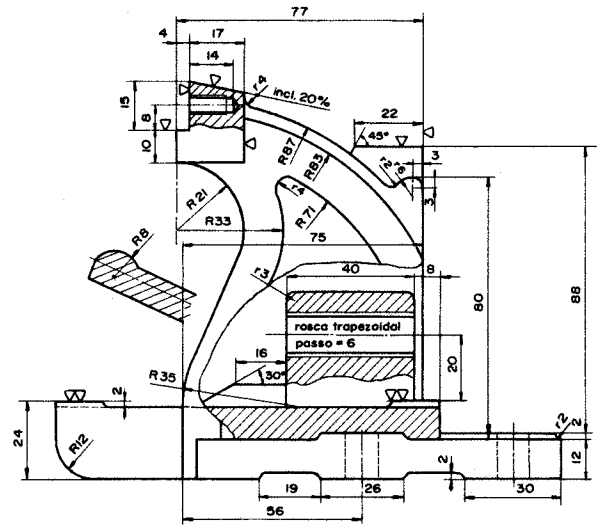

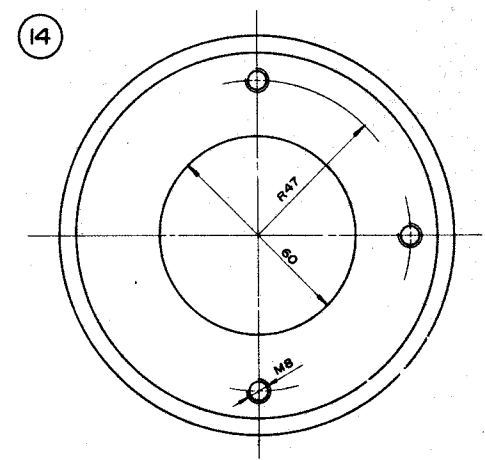
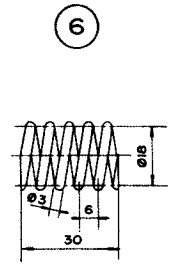
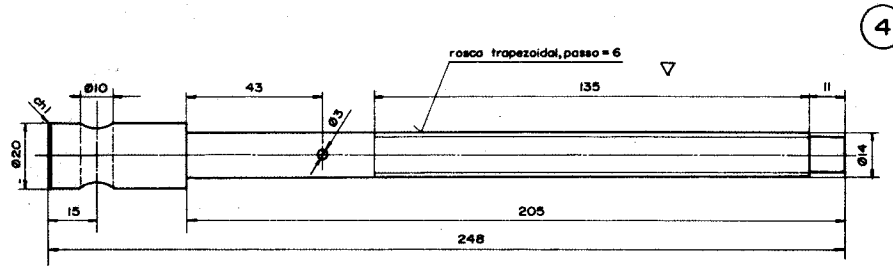
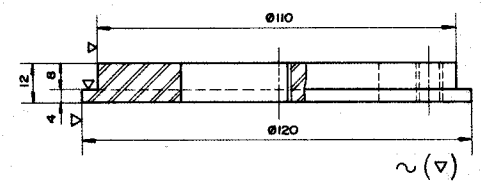
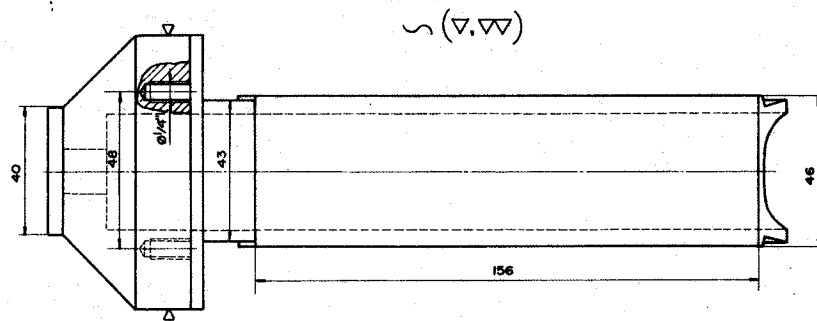
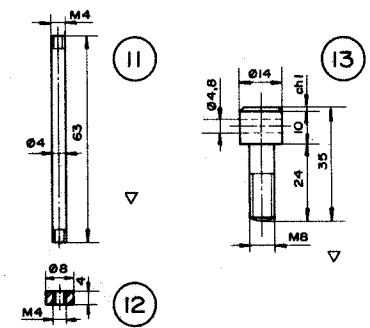
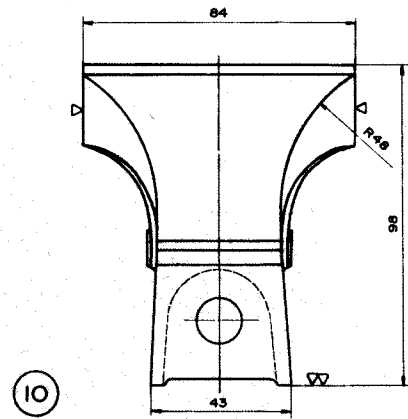
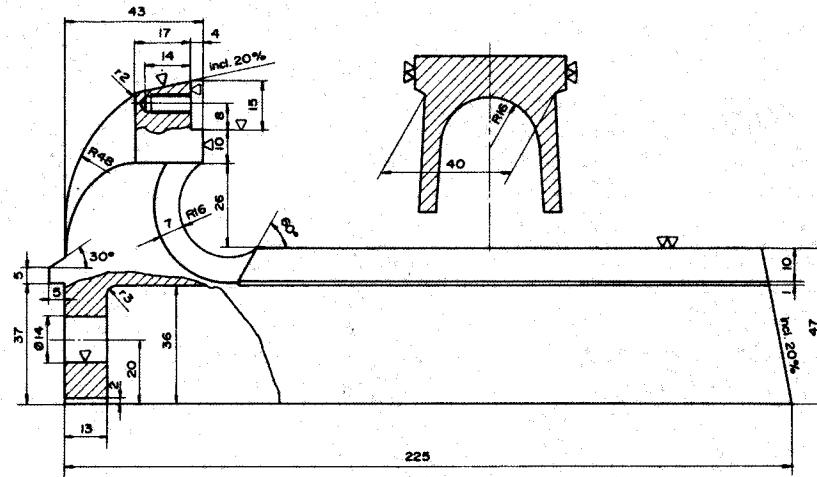

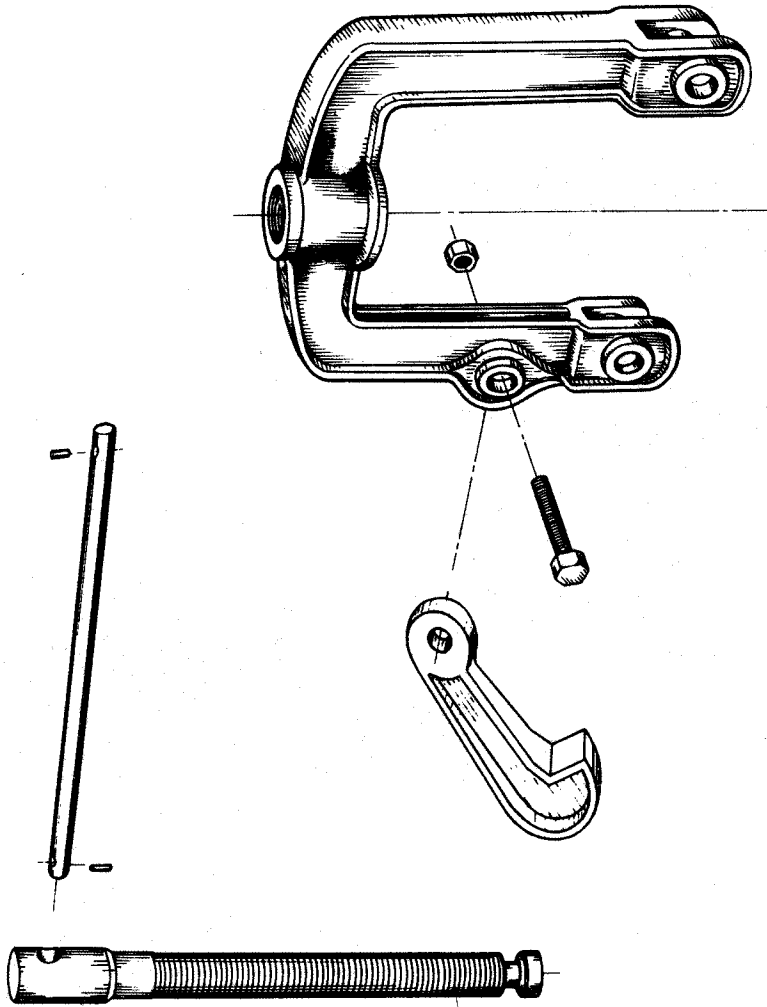

MORSA PARA CANOS

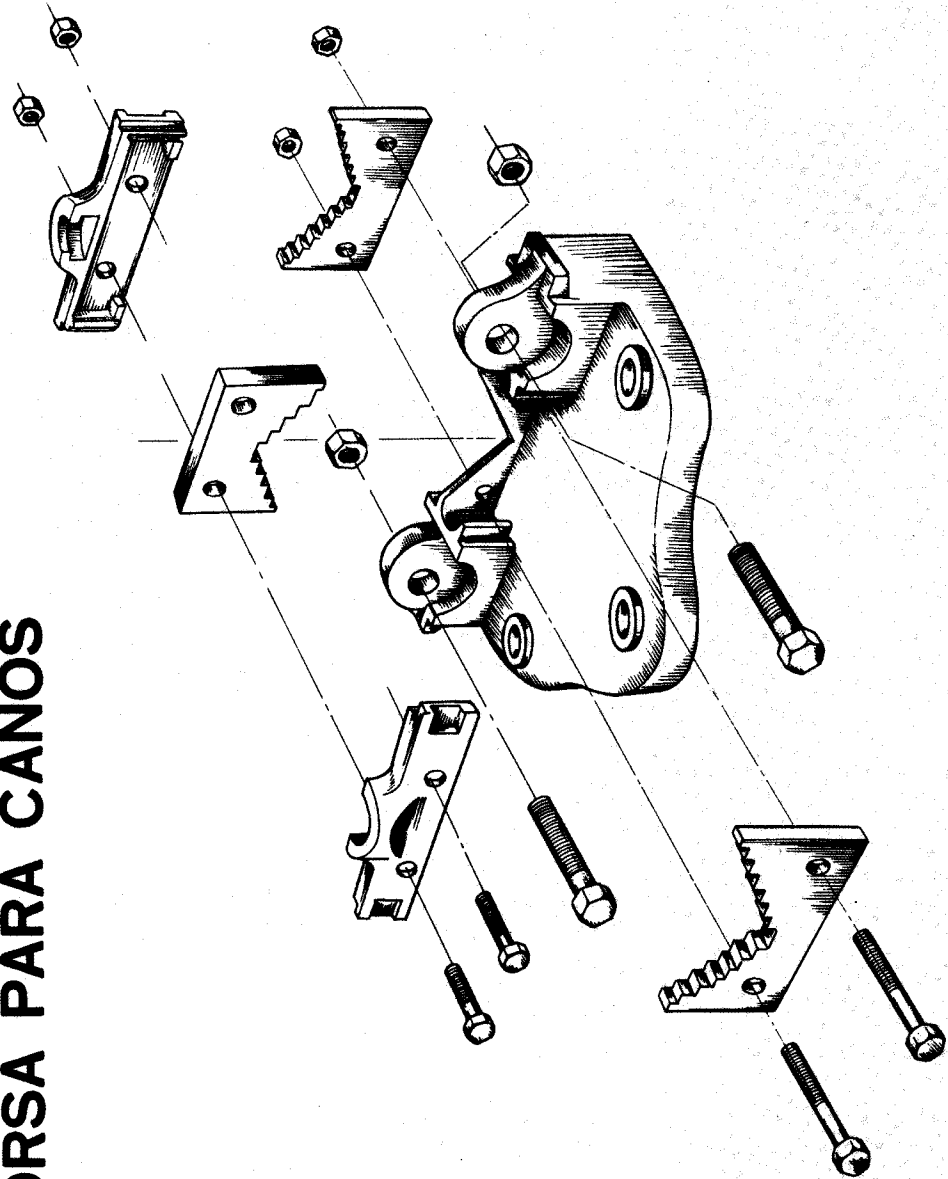

MORSA PARA CANOS

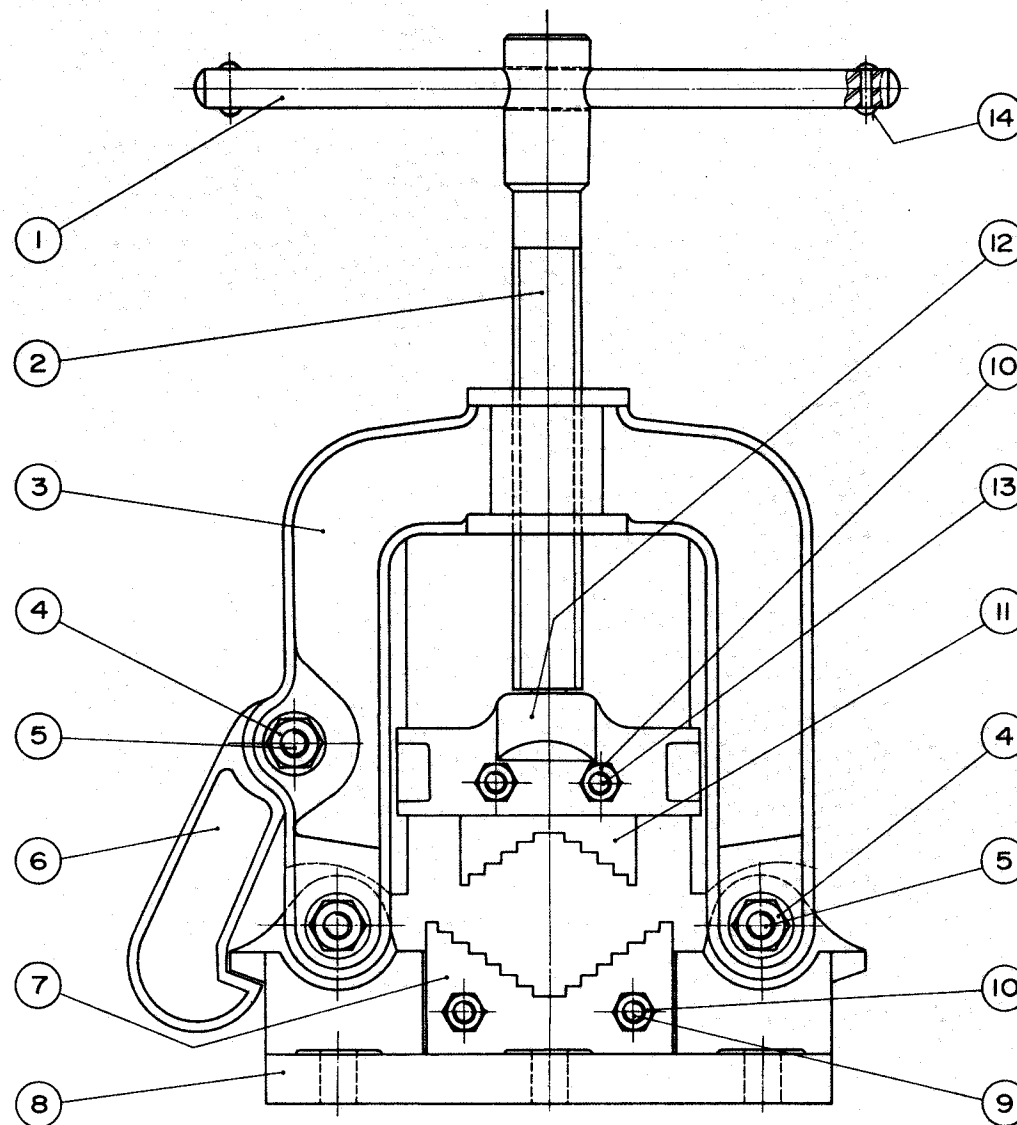

Nº	DENOMINAÇÕES	Quant.	MATERIAL E DIMENSÕES
14	Pino	2	Ferro Ø3x18
13	Paraf. cab. sext.	2	Ferro Ø1/4" x 7/8"
12	Guia	2	Aço 3525 AF 86x34 x14
11	Garra superior	1	Aço NB 1020 50x37x9
10	Porca sext.	4	Ferro Ø1/4"
9	Paraf. cab. sext.	2	Ferro Ø1/4" x 1 3/4"
8	Base	1	Aço 3525 AF 180x118x64
7	Garra inferior	2	Aço NB 1020 70x37x8
6	Trava	1	Aço 3525 AF
5	Paraf. cab. sext.	3	Ferro Ø3/8" x 1 1/2"
4	Porca sext.	3	Ferro Ø3/8"
3	Corpo	1	Aço 3525 AF Ø46x165x161
2	Paraf. de aperto	1	Aço NB 1020 Ø24x195
1	Braço	1	Aço NB 1010 Ø3/8" x 200

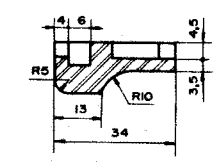
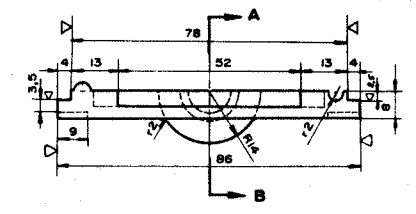
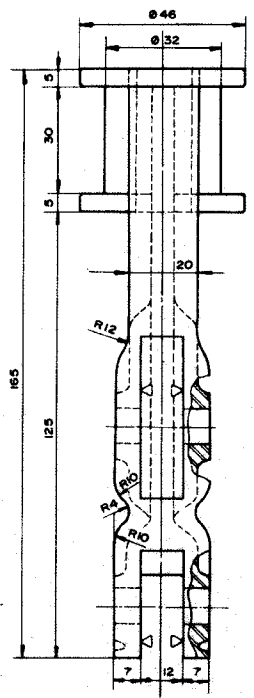
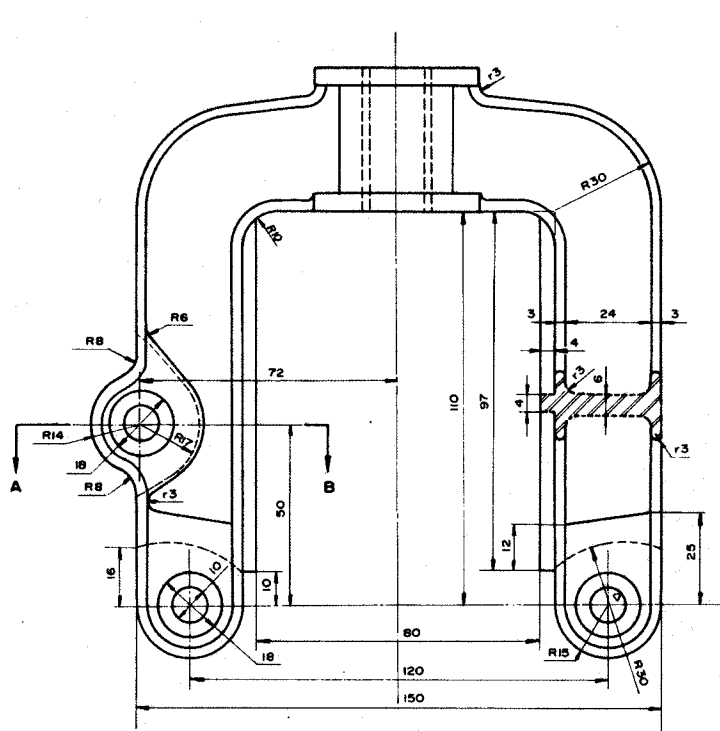

~ (▽)

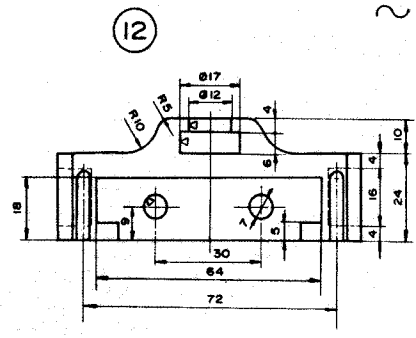

3

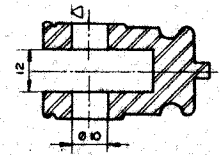
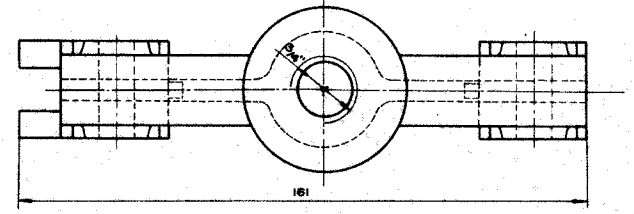

corte AB

~ (▽)

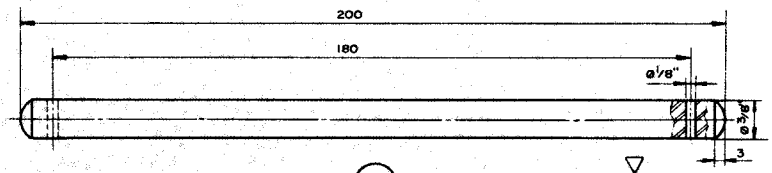

1

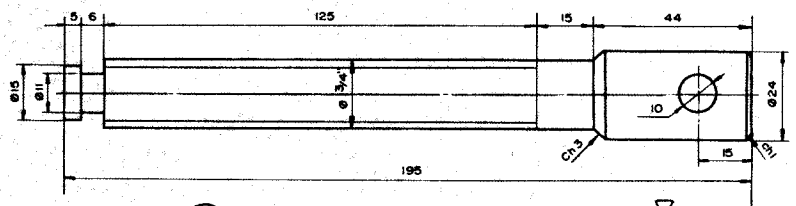

2

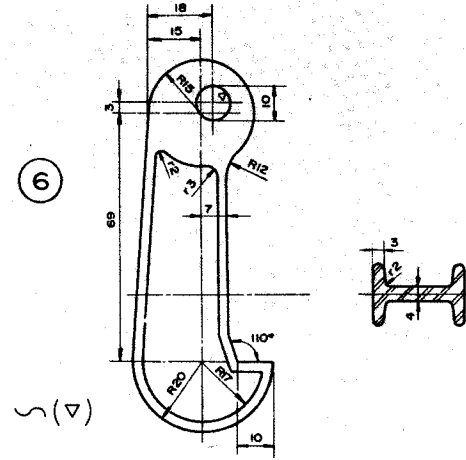
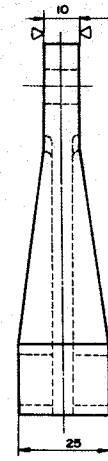
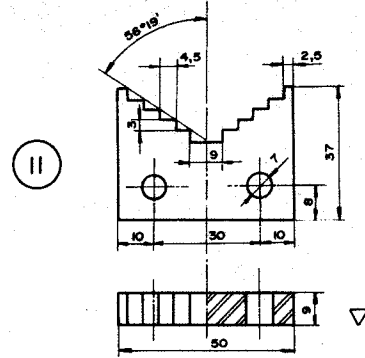
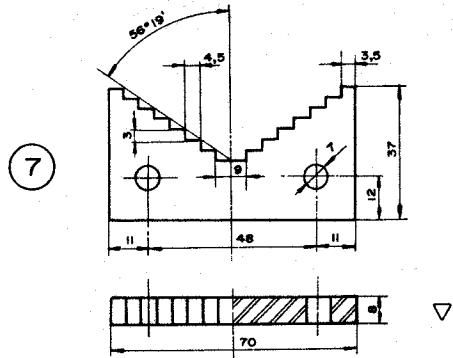
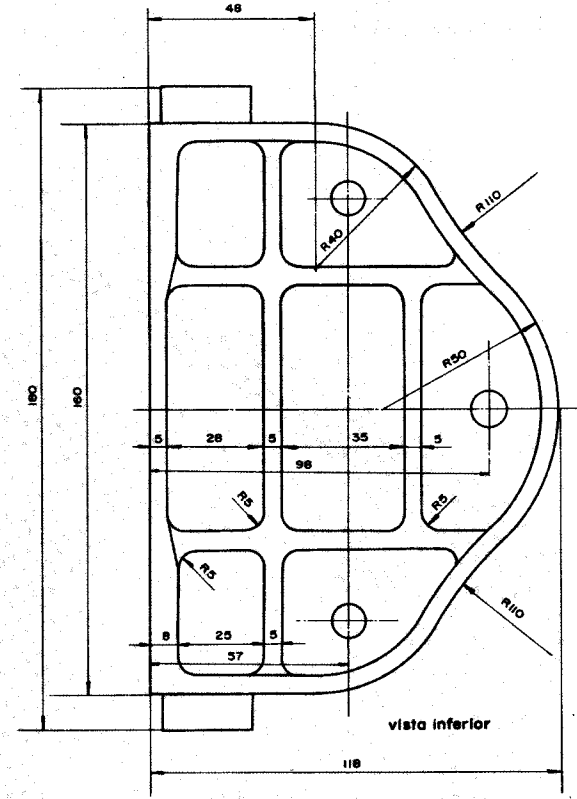
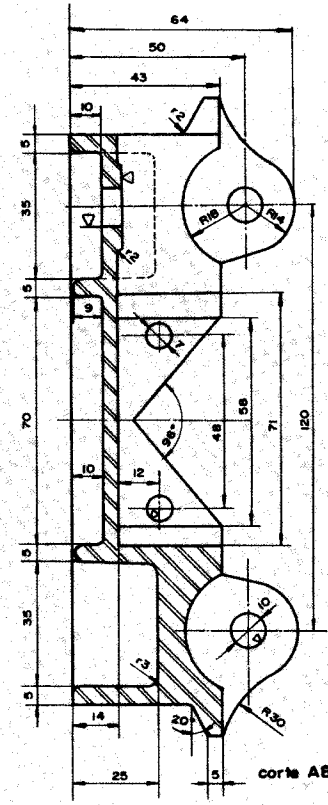
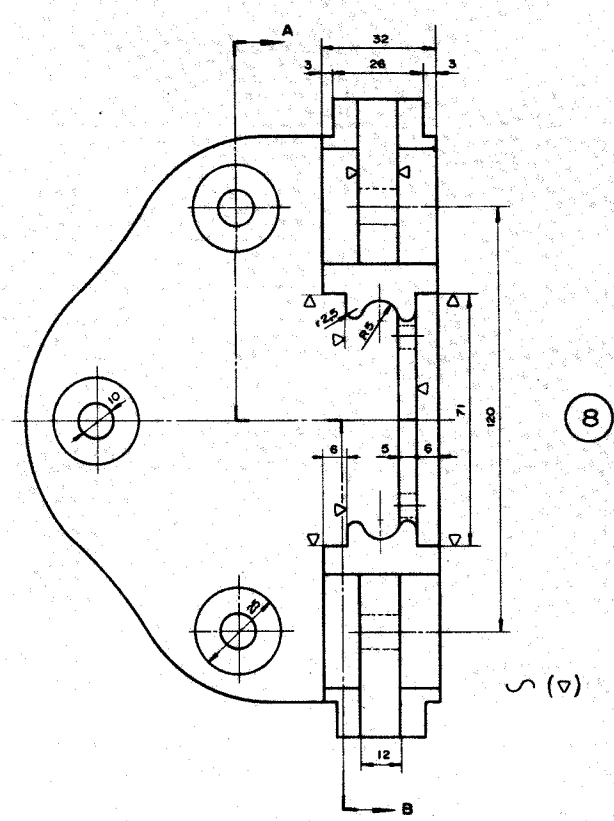

FURADOR

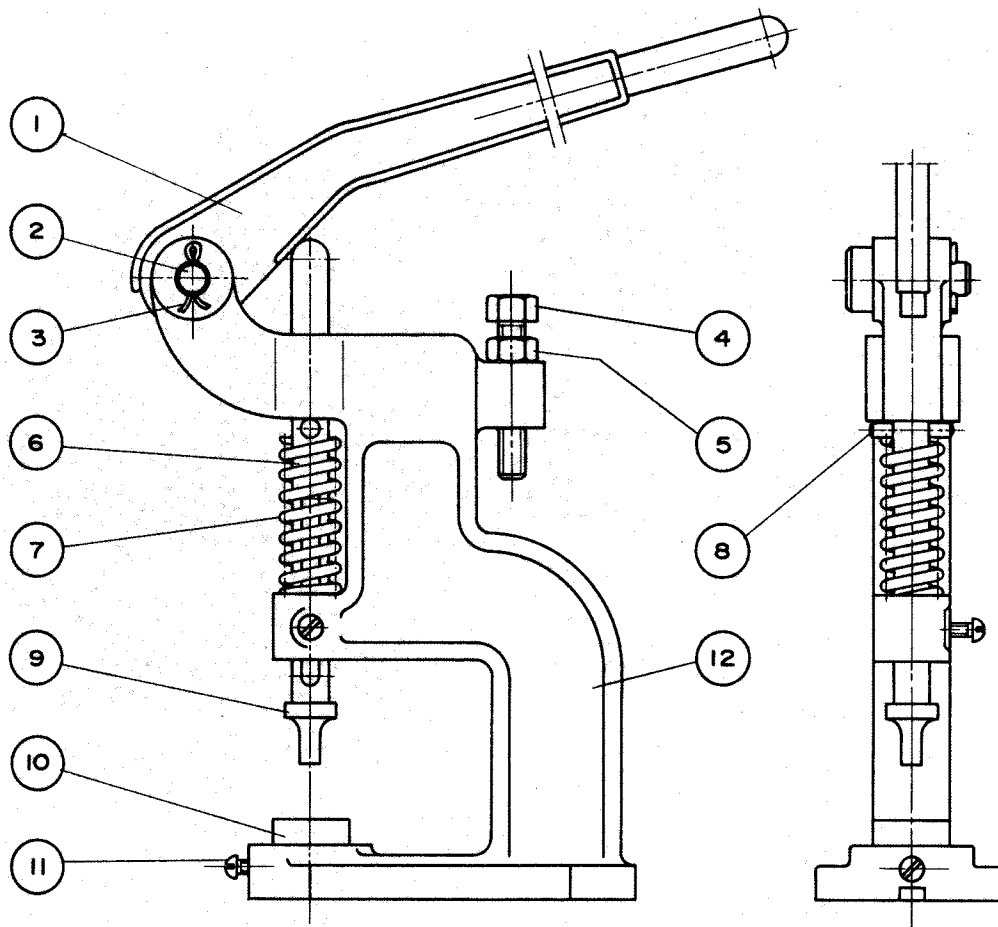
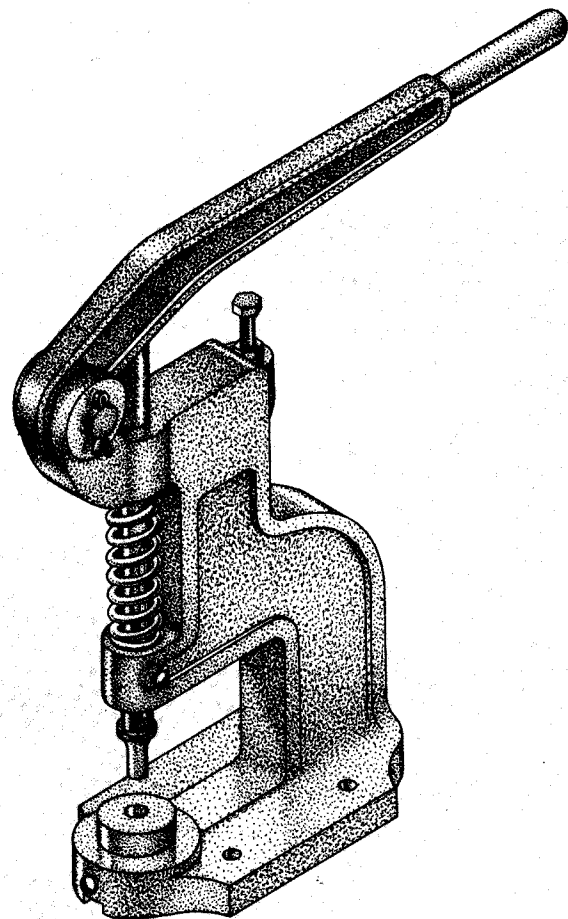

12	Corpo	1	Aço fundido 3525 AF	5	Porca sext.	1	Ø 5/8"
11	Paraf c/cab. red.	2	Ø 5/16" x 7/8"	4	Parafuso sext.	1	Ø 5/8" x 3 1/2"
10	Matriz	1	Aço RCC Temp. retif.	3	Contra-pino	1	Aço Ø 1/4" x 40
9	Punção	1	Aço RCC Temp. retif.	2	Pino c/cabeça	1	Aço NB 1020
8	Pino conico	1	Aço prata Ø 3/16" x 45	1	Alavanca	1	Aço fundido 3525 AF
7	Mola	1	Aço NB 1070	Nº	DENOMINAÇÕES	Quant.	MATERIAL E DIMENSÕES
6	Porta-punção	1	Aço NB 1020 Temp. cement.				

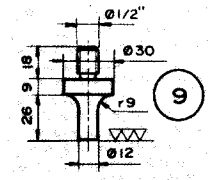
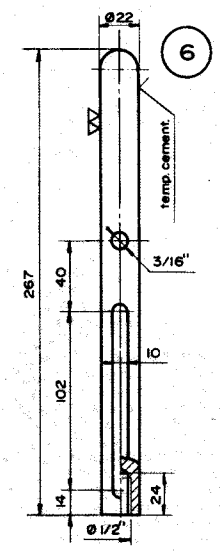
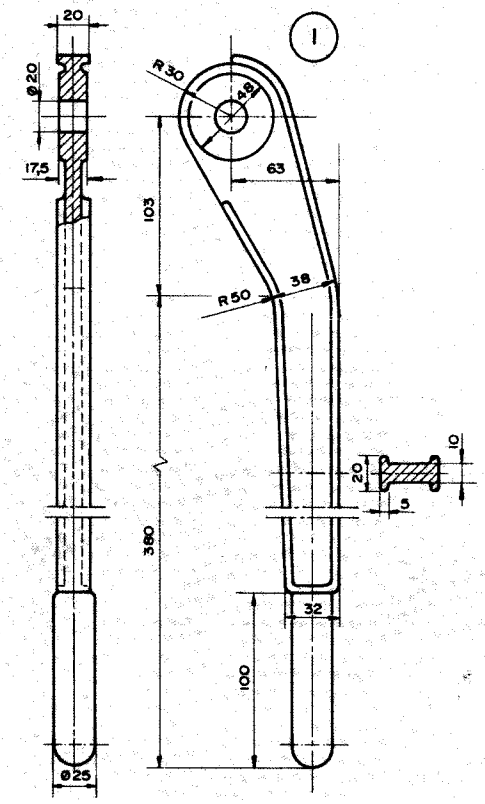
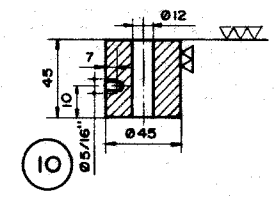
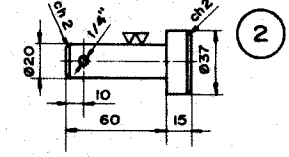
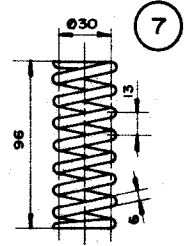
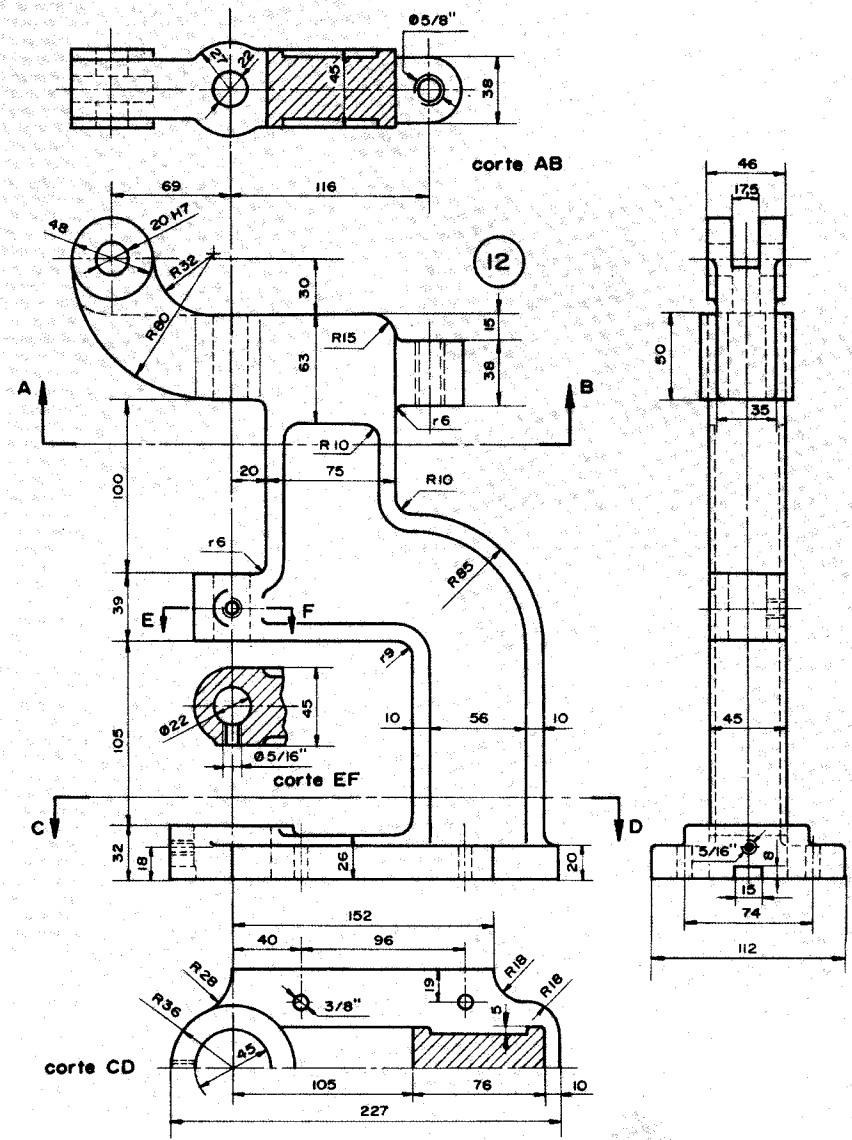

TESOURÃO DE BANCADA

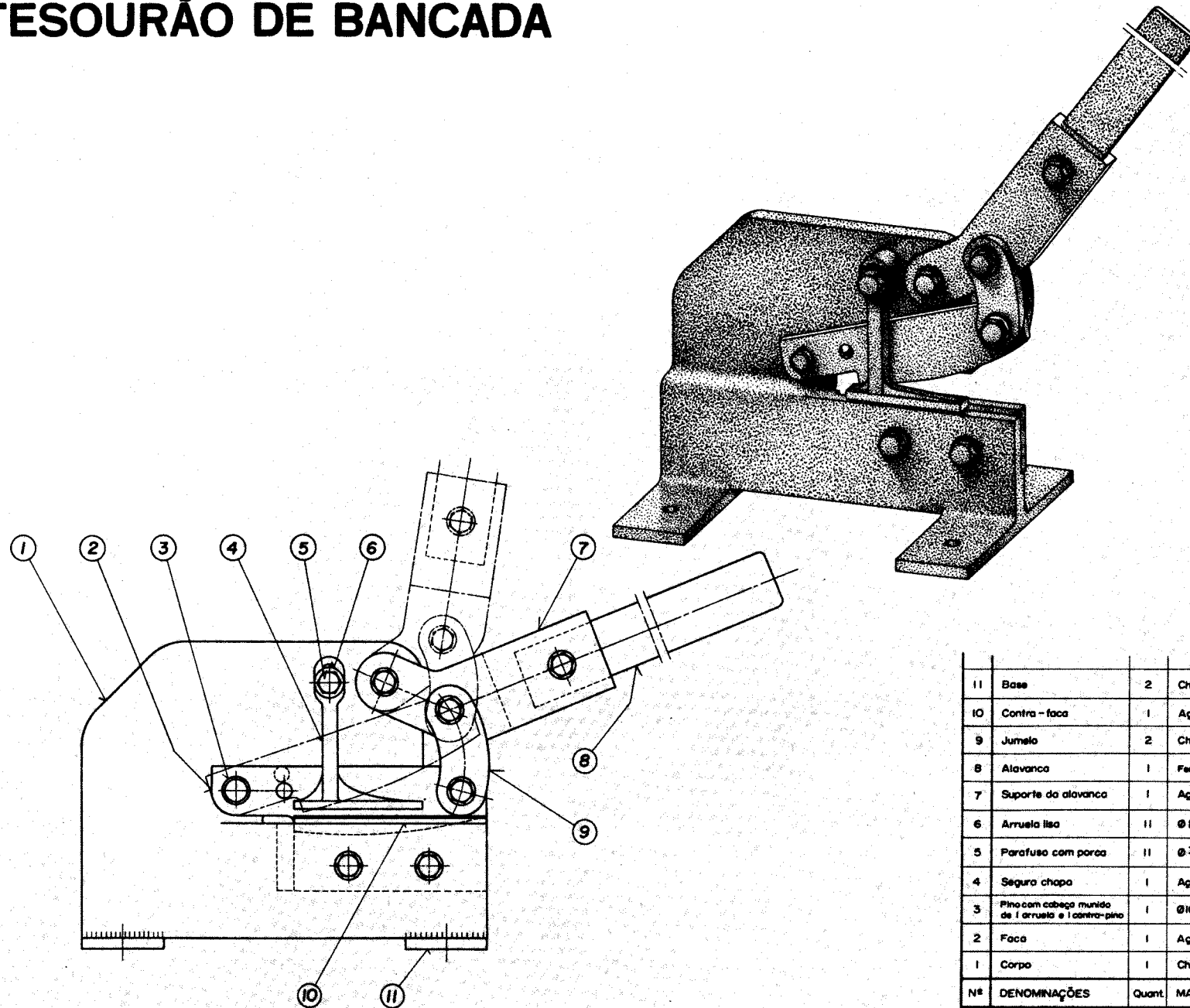

11	Base	2	Chapa de aço $\frac{5}{16}$ "
10	Contra-faca	1	Aço Villares VW-3
9	Junelo	2	Chapa de aço $\frac{5}{16}$ "
8	Alavanca	1	Ferro chato $\frac{3}{8}$ " x $1\frac{3}{8}$ " x 1000
7	Suporte da alavanca	1	Aço fundido 7010 AF
6	Arruela lisa	11	$\varnothing 10$ DIN-1440
5	Parafuso com porca	11	$\varnothing \frac{3}{8}$ " x 45
4	Segura chapa	1	Aço fundido 3525 AF
3	Pinho com cabeça munido de 1 arruela e 1 contra-pinho	1	$\varnothing 10$ x $\varnothing 26,5$ - 30
2	Faca	1	Aço Villares VW-3
1	Corpo	1	Chapa de aço $\frac{5}{8}$ "
Nº	DENOMINAÇÕES	Quant.	MATERIAL E DIMENSÕES

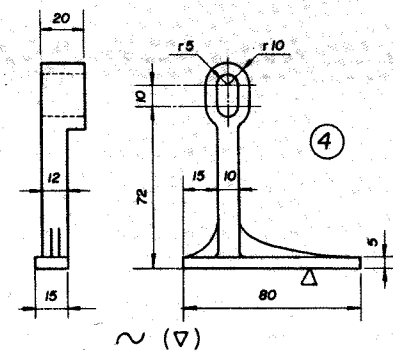
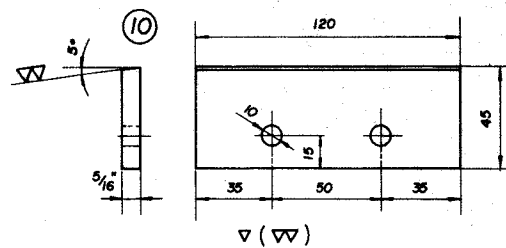
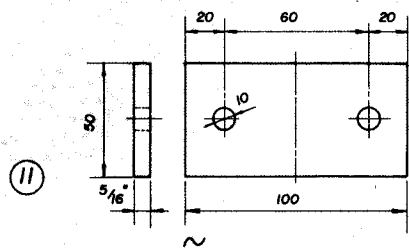
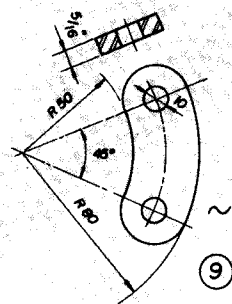
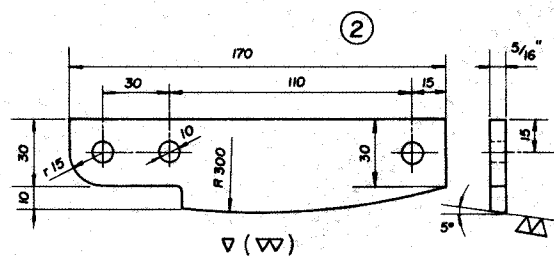
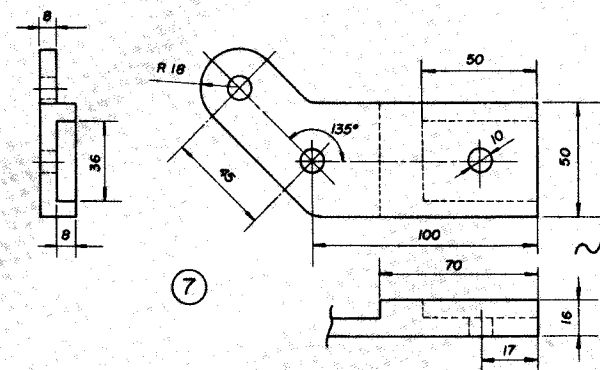
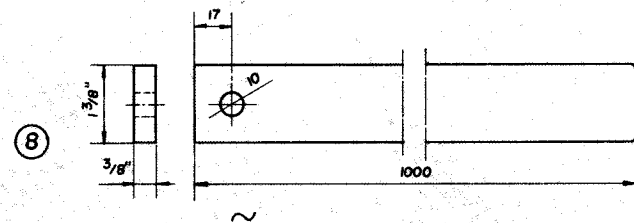
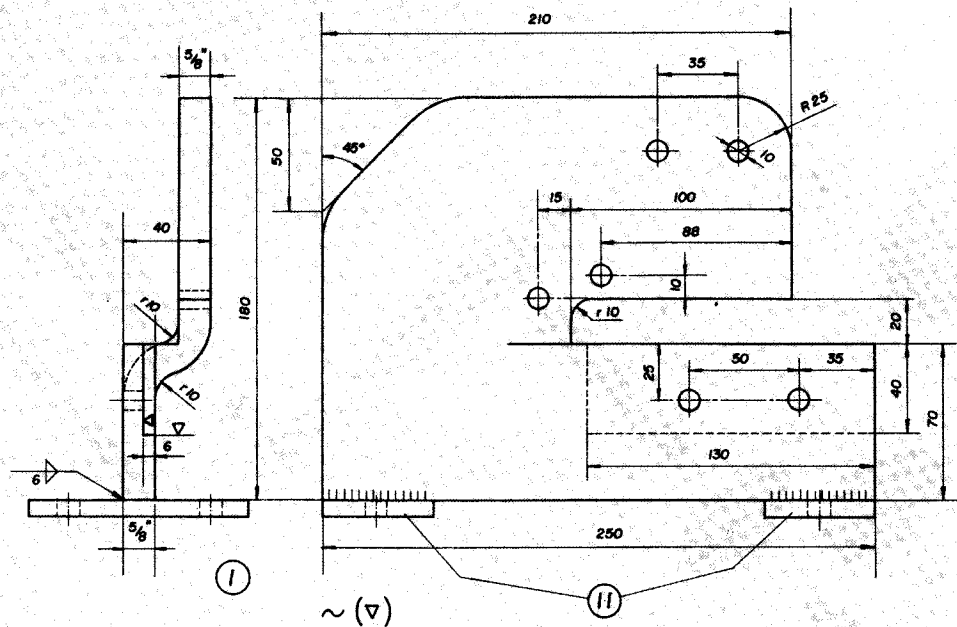

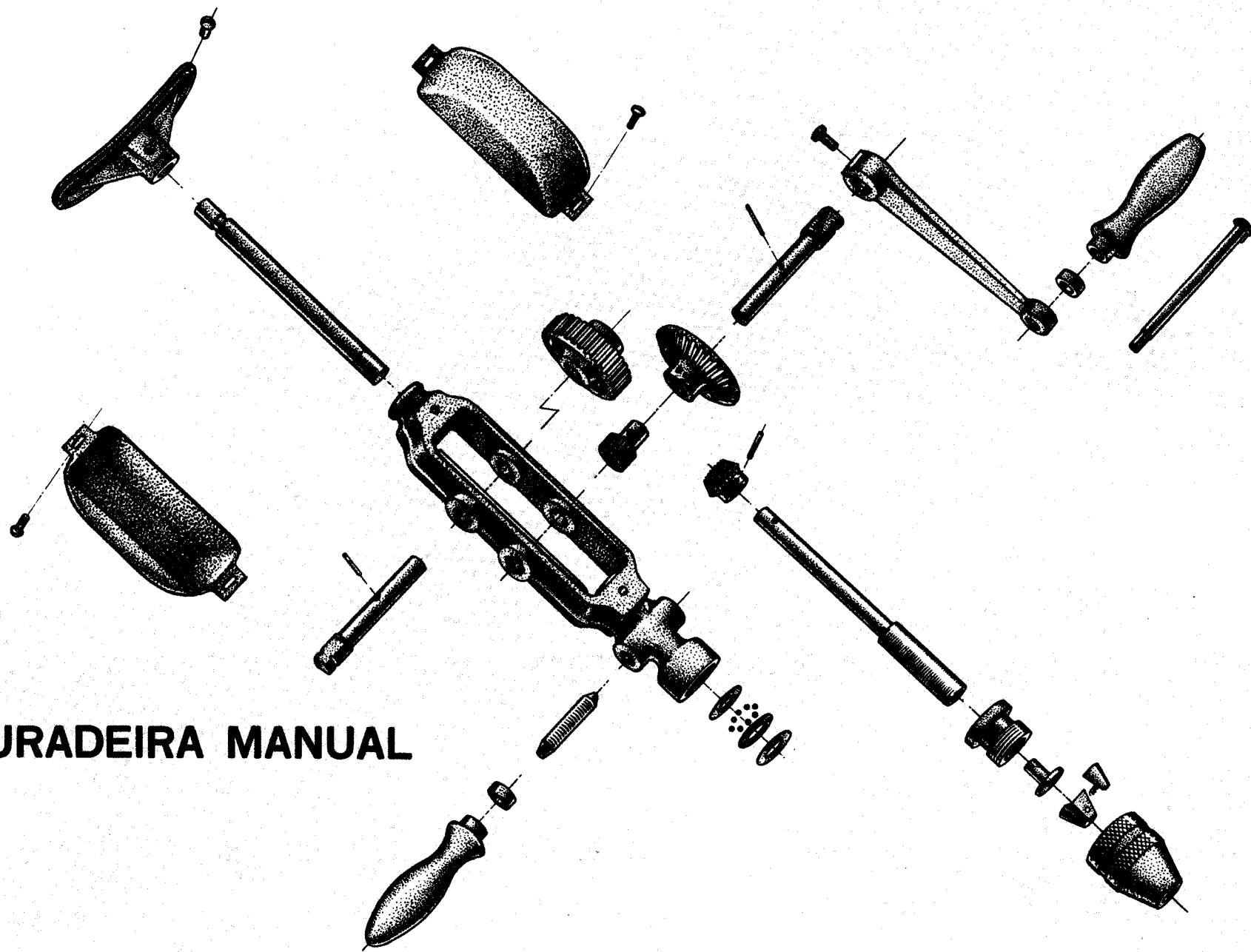

FURADEIRA MANUAL

FURADEIRA MANUAL

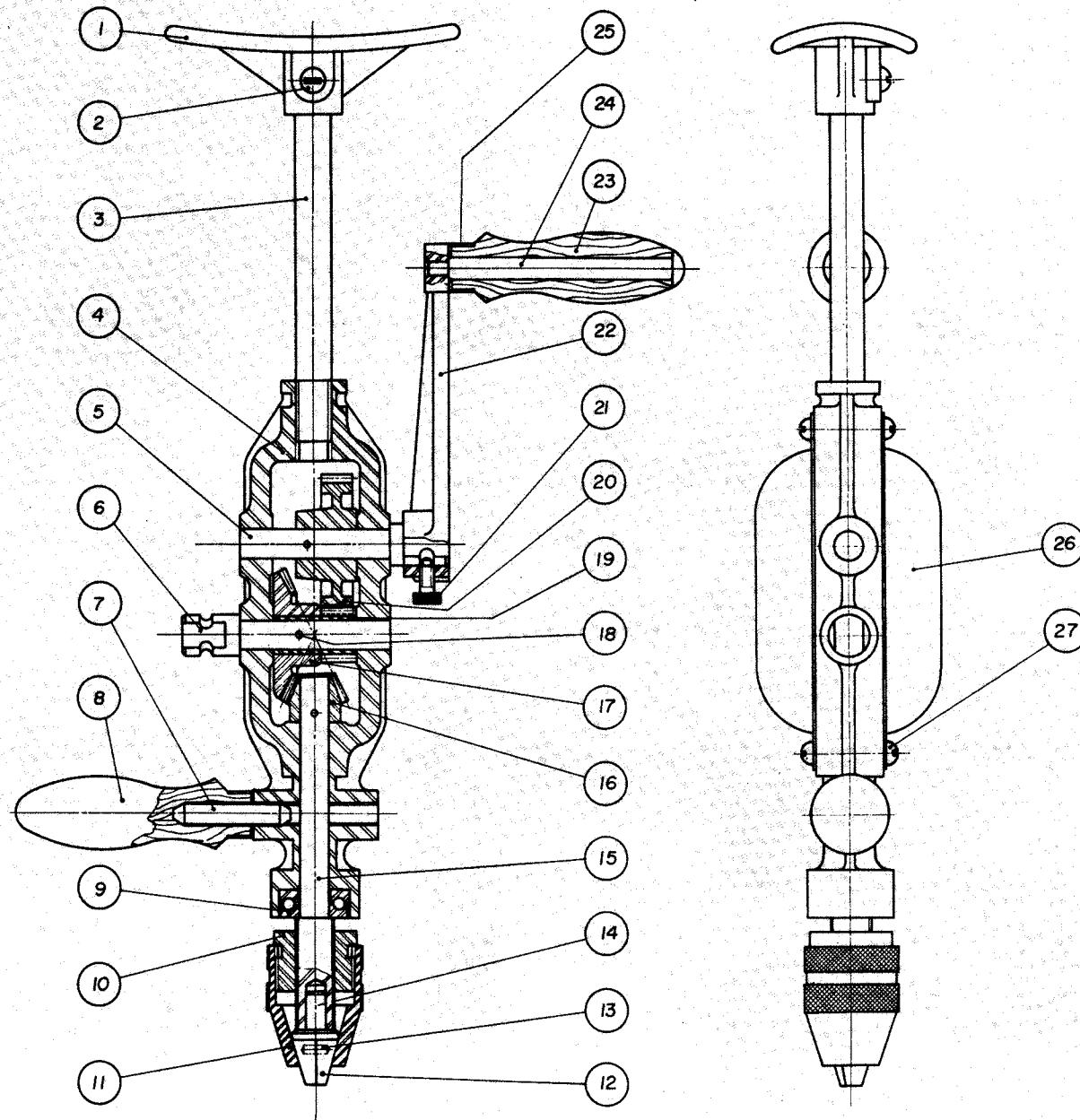

27	Paraf. cab. red.	4	Ferro $\phi 1/8" \times 3/16"$
26	Caixa de proteção	2	Chapa preta BG # 20
25	Capa da base do punho	2	Chapa preta BG # 20
24	Pino do punho	1	Ferro
23	Punho do manivela	1	Madeira
22	Manivela	1	Aço fundido 3525 AF
21	Paraf. de fixação	1	Ferro M5x10
20	Coroa cilíndrica	1	Aço NB 1030
19	Pinhão cilíndrico	1	Aço NB 1030
18	Pino de fix. dos engrn.	3	Ferro $\phi 3 \times 22$
17	Coroa cônica	1	Aço NB 1030
16	Pinhão cônico	1	Aço NB 1030
15	Eixo	1	Aço NB 1020
14	Pino de ejeção	1	Aço NB 1010
13	Mola	3	Aço NB 5150
12	Castanha	3	Aço NB 1020 ^{temp. convant.}
11	Capa do mandril	1	Aço NB 1020
10	Parca reguladora	1	Aço NB 1020
9	Rolamento axial	1	SKF 5100 $\phi 24 \times 9$
8	Punho fixo	1	Madeira
7	Paraf. s/cab. do punho fixo	1	Ferro $\phi 5/16" \times 40$
6	Eixo superior	1	Aço NB 1020 $\phi 10 \times 70$
5	Eixo inferior	1	Aço NB 1020 $\phi 10 \times 70$
4	Chassi	1	Aço fundido 3525 AF
3	Haste do encosto	1	Aço NB 1010 $\phi 12 \times 125$
2	Paraf. de fixação do encosto	1	Ferro $\phi 3/16" \times 3/8"$
1	Encosto	1	Aço fundido 3525 AF
Nº	DENOMINAÇÕES	Quant.	MATERIAL E DIMENSÕES

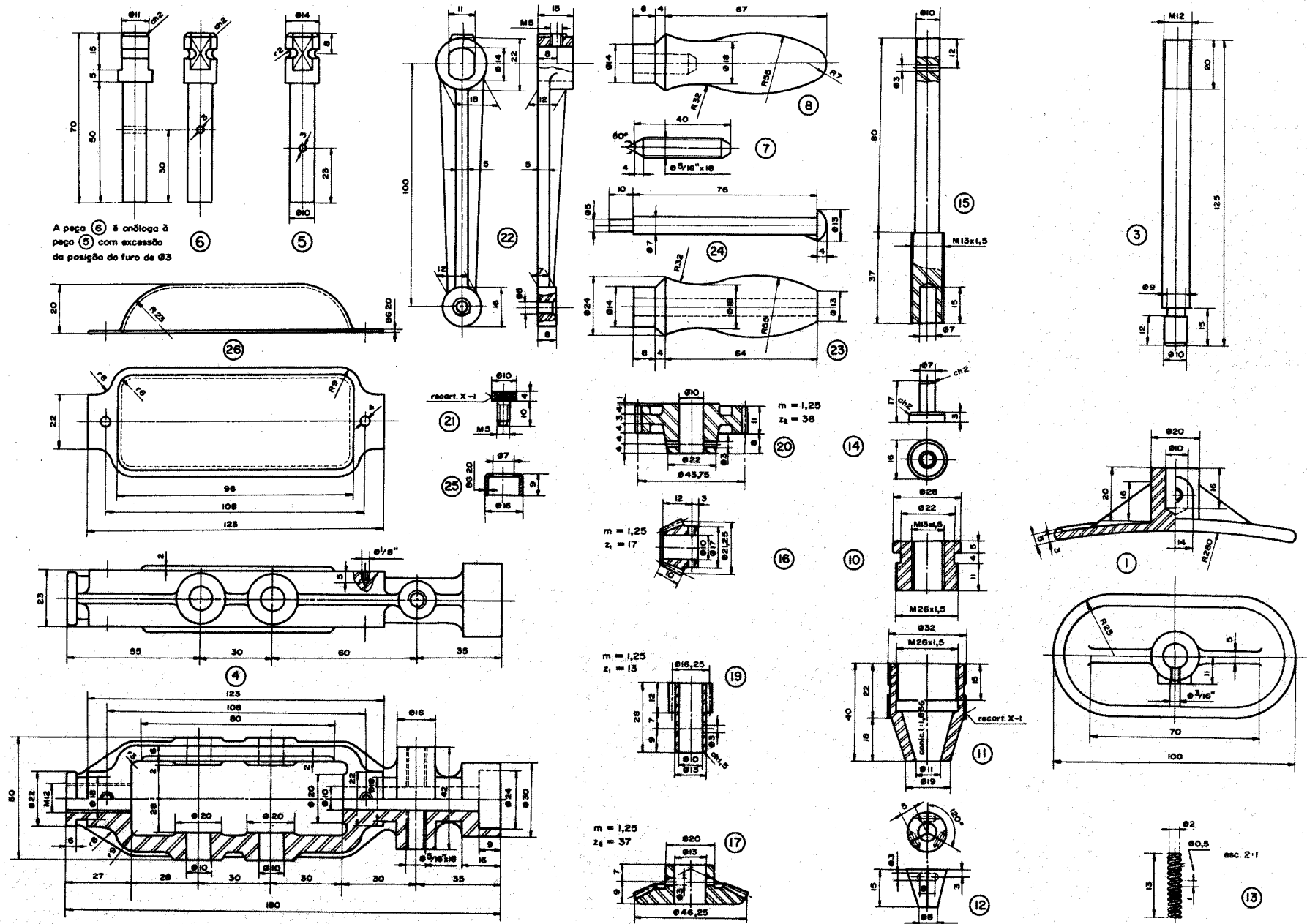

VÁLVULA DE SEGURANÇA

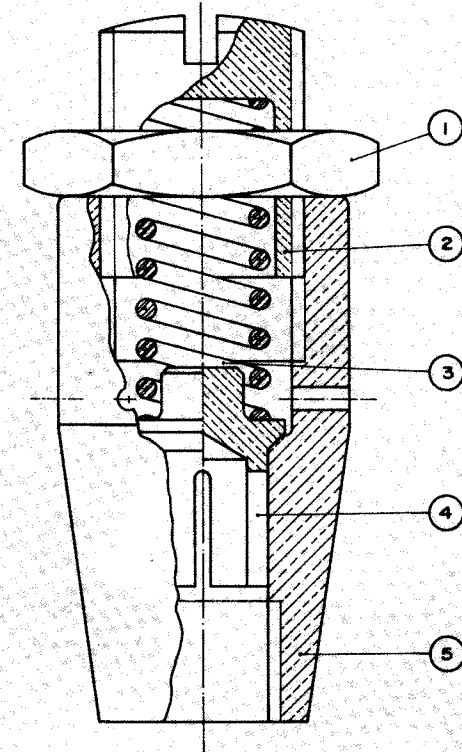
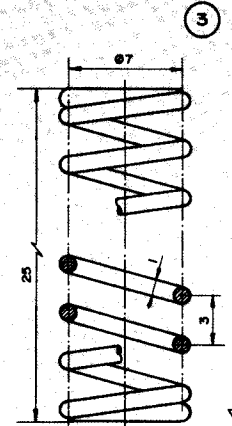
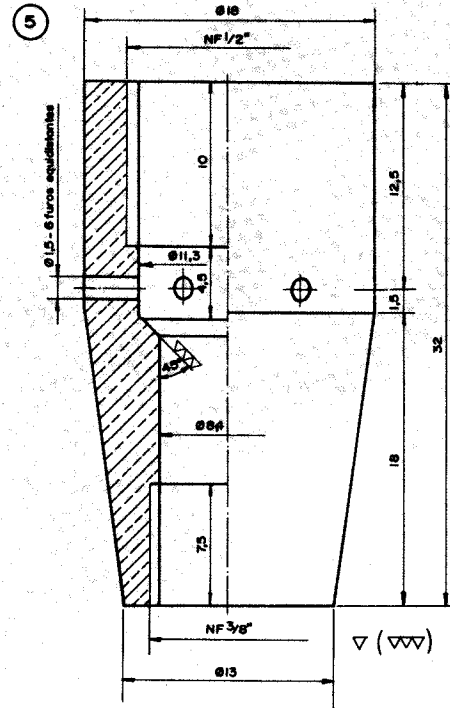
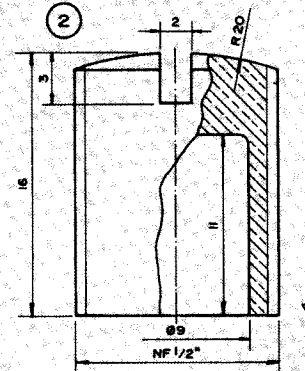
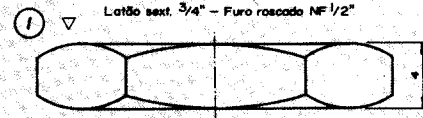
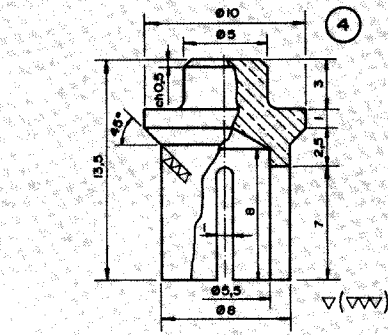
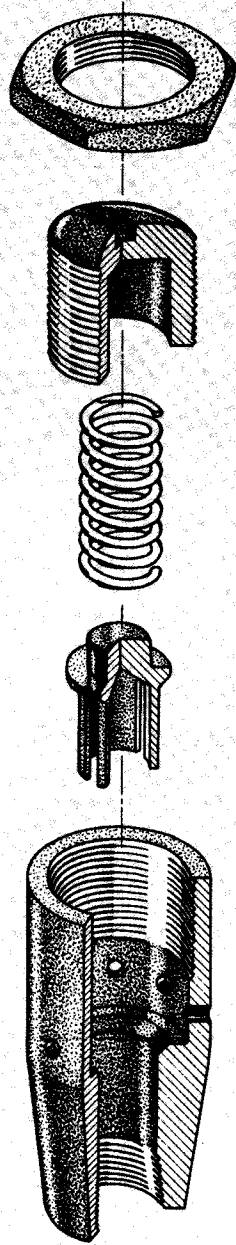

Nº	DENOMINAÇÕES	Quant.	MATERIAL E DIMENSÕES
5	Corpo	1	Latão TM - Liga "U" - Ø16x32
4	Pino	1	Latão TM - Liga "U" - Ø10x13,5
3	Mola	1	Aço NB 1070 BWG # 18
2	Parafuso	1	Latão TM - Liga "U" - NF 1/2"x16
1	Porca sextavada	1	Latão sext. D = 18 Liga "U" TM NF 1/2"x4

BOMBINHA DE ÓLEO

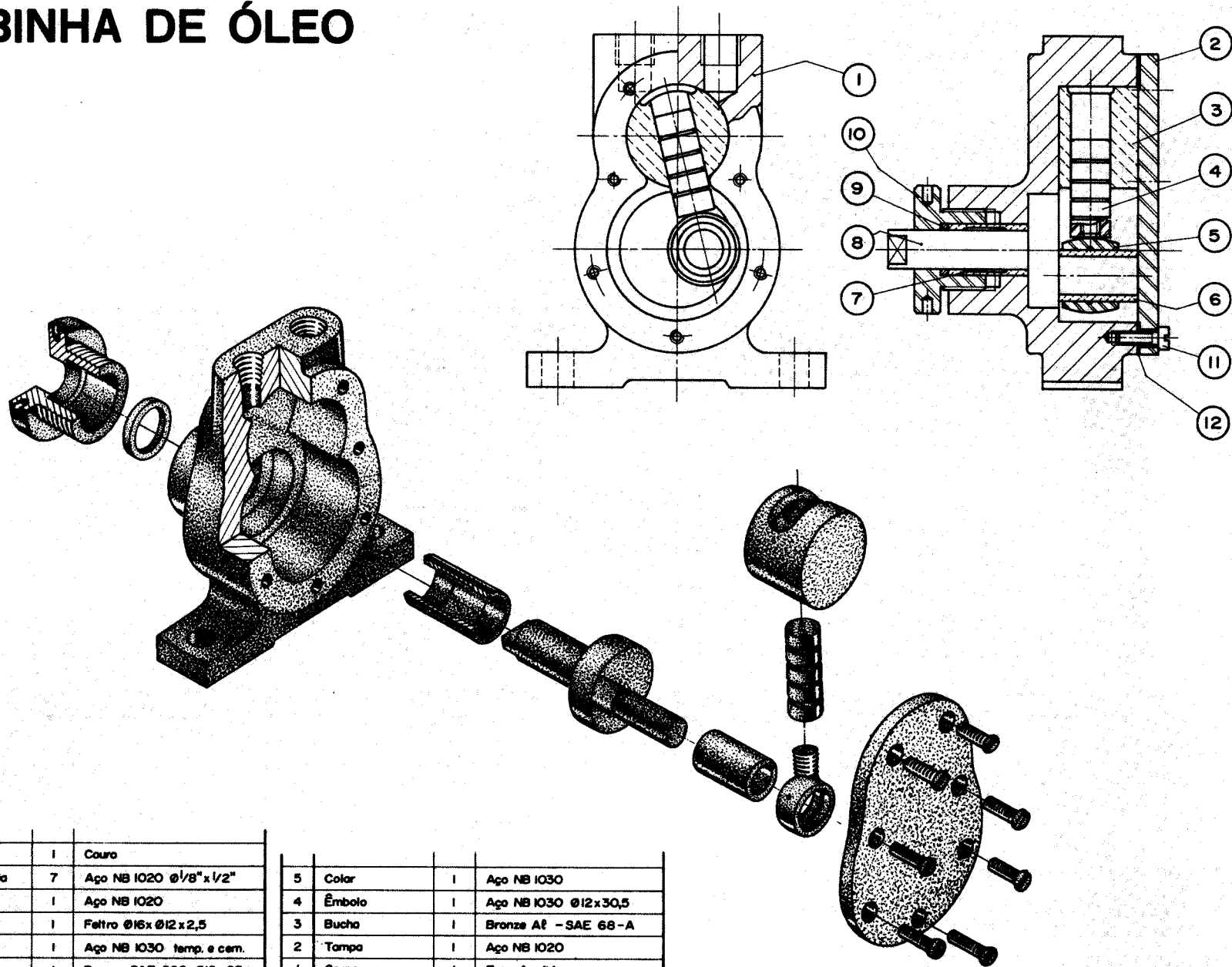

12	Guarnição	1	Couro
11	Paraf. de fenda	7	Aço NB 1020 @1/8" x 1/2"
10	Tampão	1	Aço NB 1020
9	Vedação	1	Feltro Ø16x Ø12x2,5
8	Eixo	1	Aço NB 1030 temp. e cam.
7	Bucha	1	Bronze SAE 660 Ø12x25
6	Bucha	1	Bronze SAE 660 Ø12x25

5	Color	1	Aço NB 1030
4	Êmbolo	1	Aço NB 1030 Ø12x30,5
3	Bucha	1	Bronze Al - SAE 68 - A
2	Tampa	1	Aço NB 1020
1	Corpo	1	Ferro fundido
Nº	DENOMINAÇÕES	Quant.	MATERIAL E DIMENSÕES

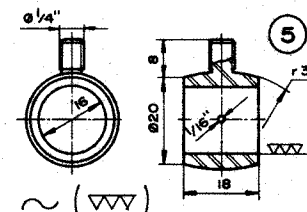
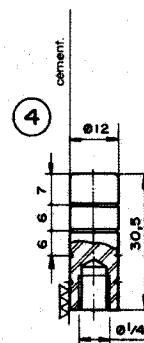
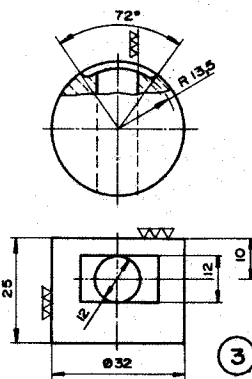
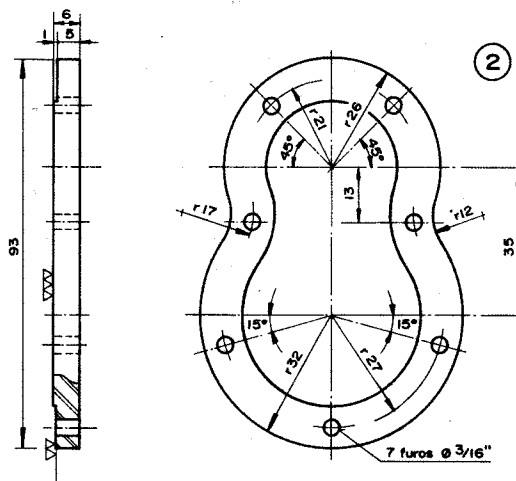
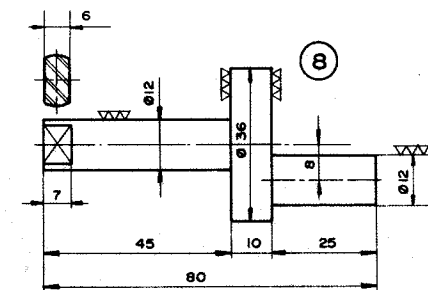
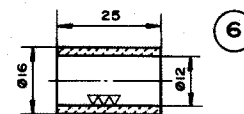
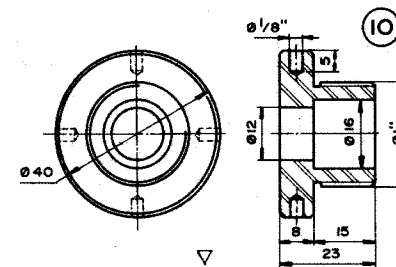
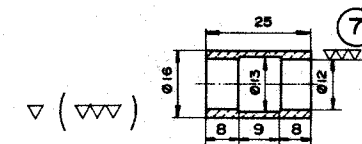
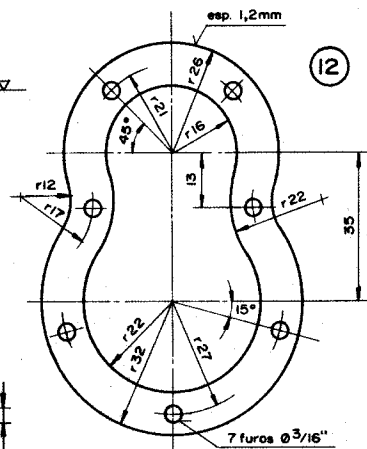
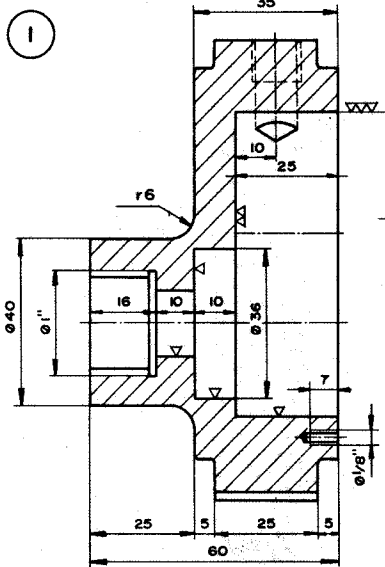
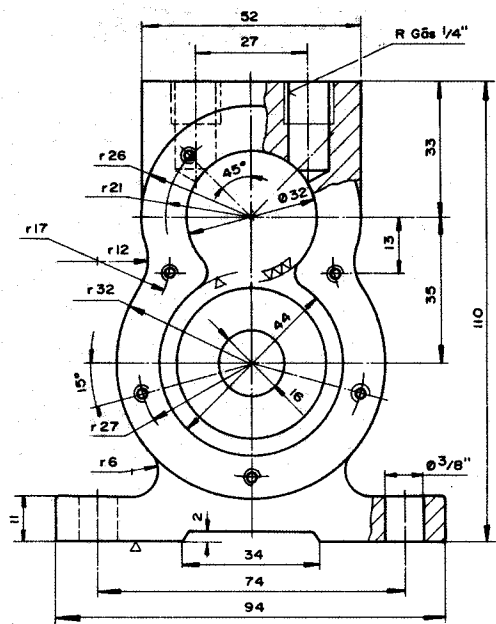

▽ (▽▽▽)

▽ (▽▽)

▽ (▽▽)

INFLADOR

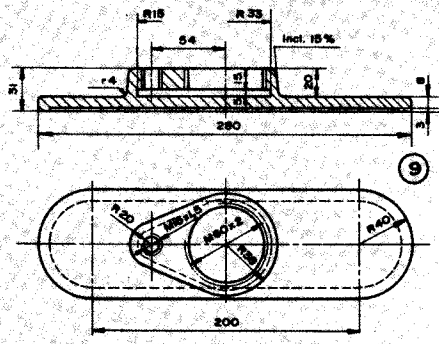
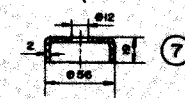
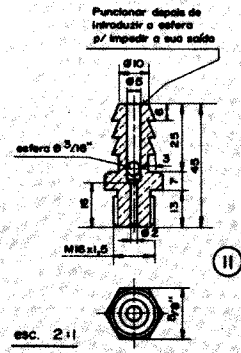
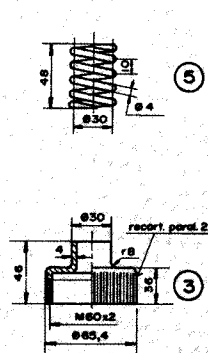
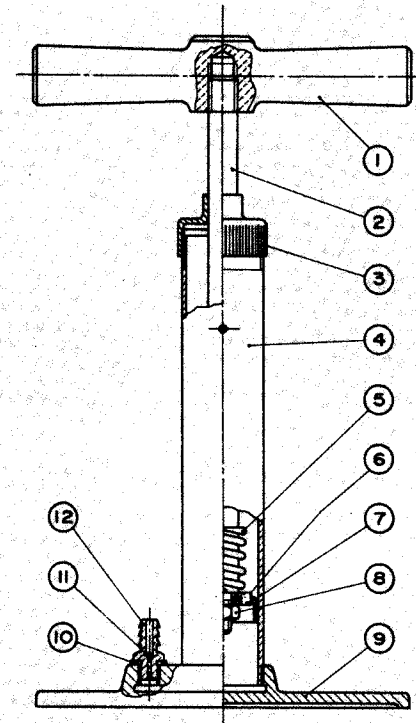
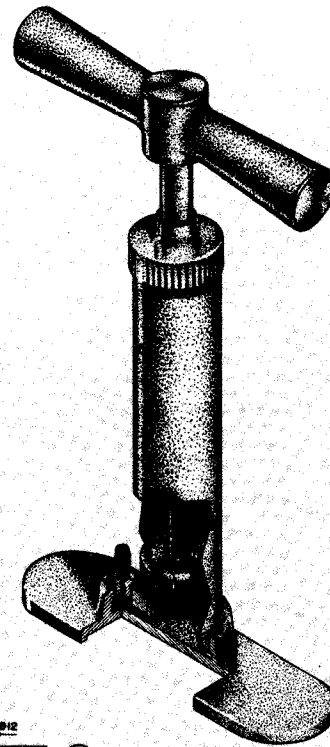
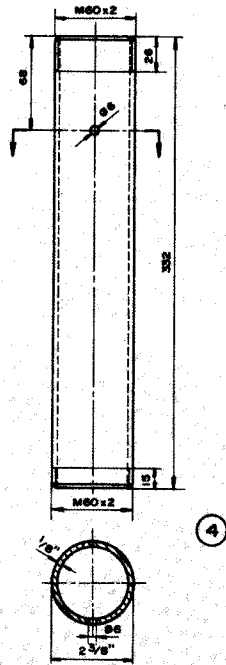
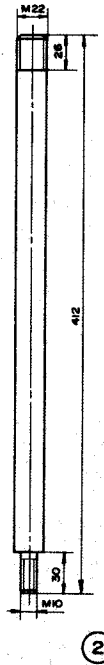
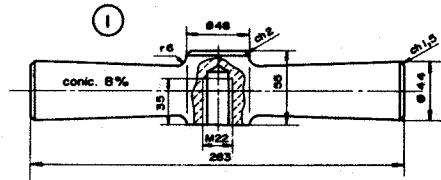

Nº	DENOMINAÇÕES	Quant	MATERIAL E DIMENSÕES
12	Bico	1	Latão TM - Sext 5/8" - Liga 1/2
11	Esfera	1	Aço SKF Ø 3/16"
10	Arruela	1	Couro Ø 15 x Ø 30 x 3
9	Base	1	Aço fundido NB 3525 AF
8	Parca	1	M10x8
7	Pistão	1	Couro
6	Arruela iso	2	Aço NB 1010 Ø 15 x Ø 50 x 2
5	Mola	1	Aço NB 1070 - Ø 4
4	Corpo	1	Latão LNM Ø 2 3/8" x 1/8"
3	Tampa	1	Latão TONOLLI L1
2	Moeda	1	Aço NB 1020 Ø 22 x 412
1	Manípulo	1	Alumínio TONOLLI A1

COMPRESSOR DE PALHETAS

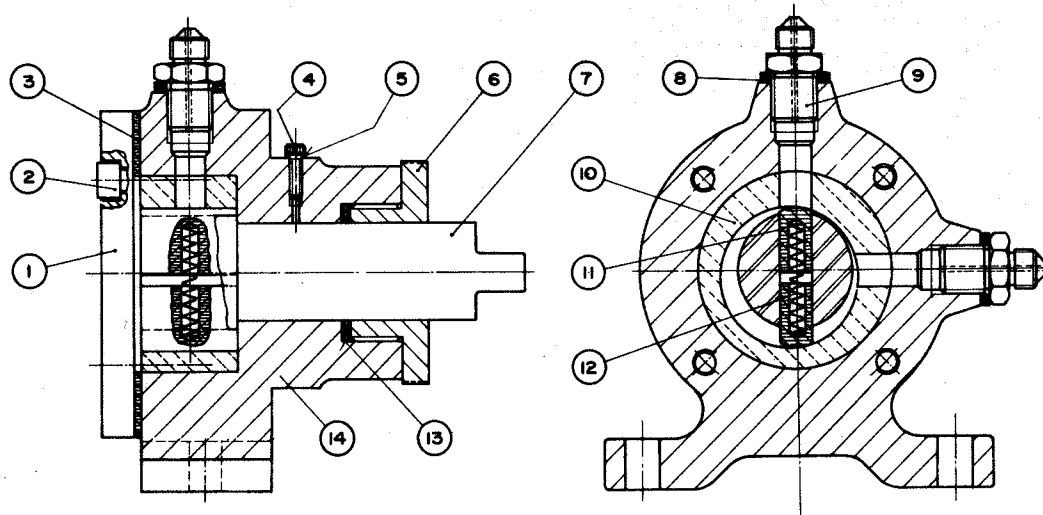
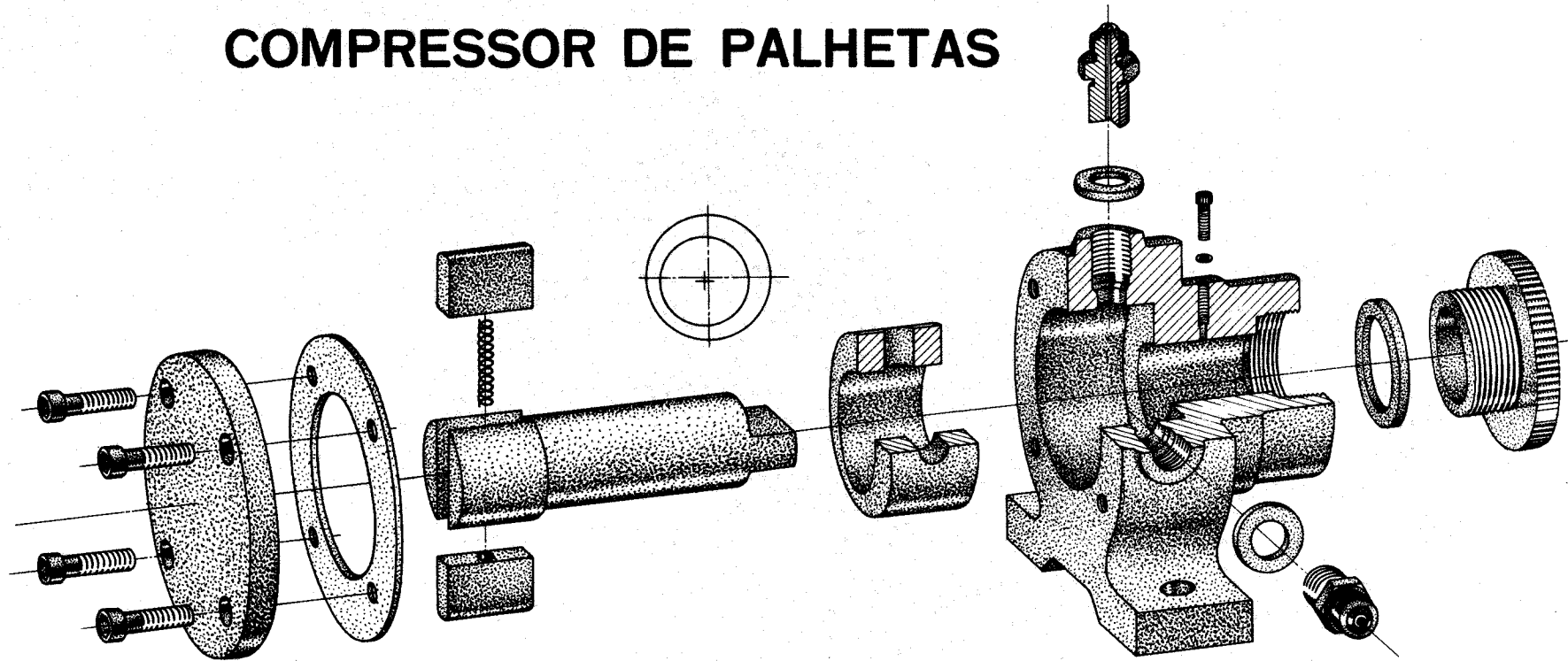

14	Corpo	1	Ferro fundido
13	Guarnição	1	Neoprene Ø 40xØ30x4
12	Mola	1	Aço p/ mola
11	Palheta	2	Fibra Celeran
10	Excêntrica	1	Bronze
9	Bico	2	Aço NB 1010
8	Guarnição	2	Neoprene Ø 24 x Ø 12 x 2
7	Eixo	1	Aço NB 1020
6	Préso estopa	1	Ferro fundido
5	Guarnição	1	Neoprene Ø 5xØ 7x1,5
4	Paraf. Allen recart.	1	# 10x12
3	Guarnição	1	Couro
2	Paraf. Allen	4	Ø 5/16"x20
1	Tampa	1	Ferro fundido
Nº	DENOMINAÇÕES	Quant.	MATERIAL E DIMENSÕES

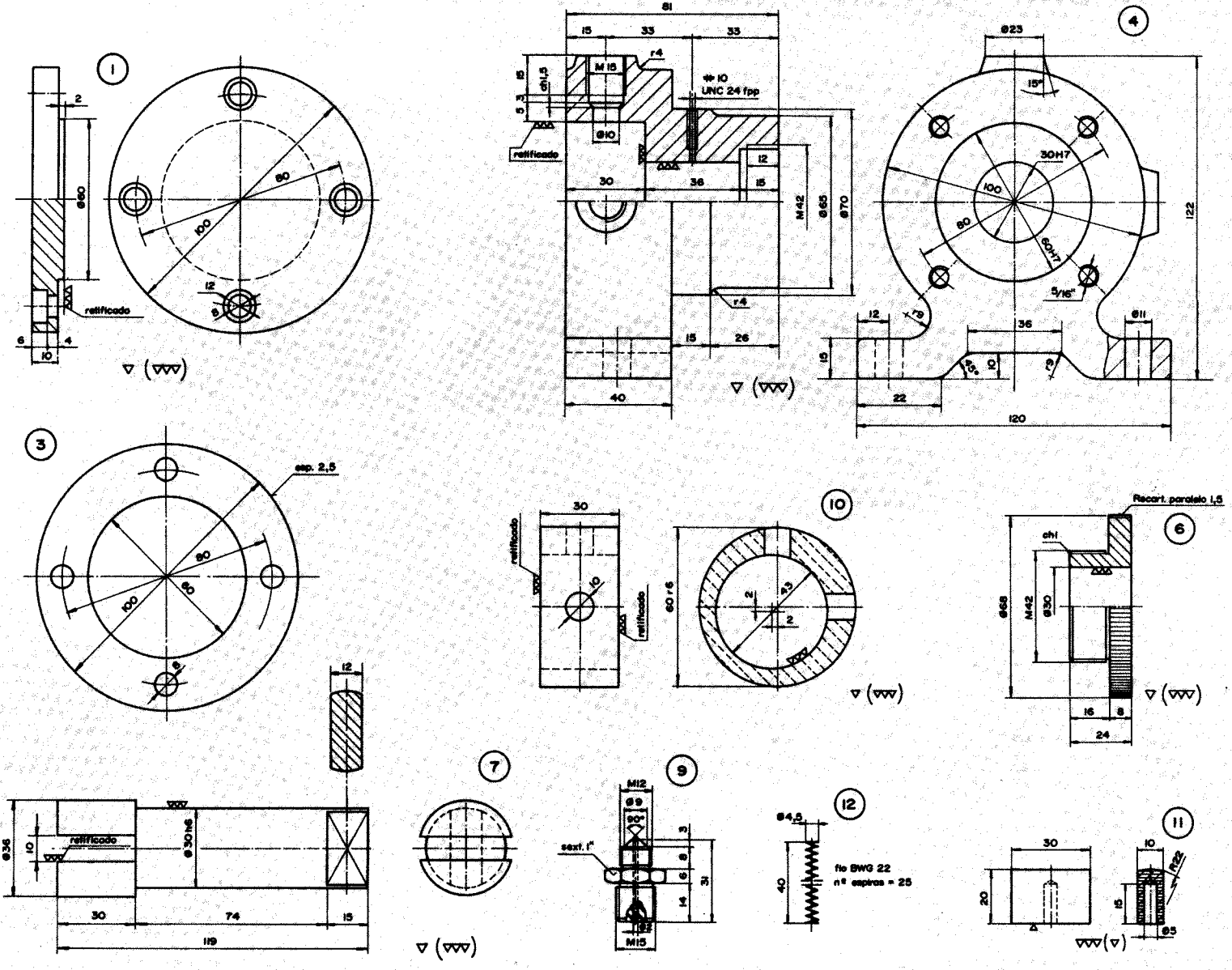

MOTO REDUTOR A AR COMPRIMIDO

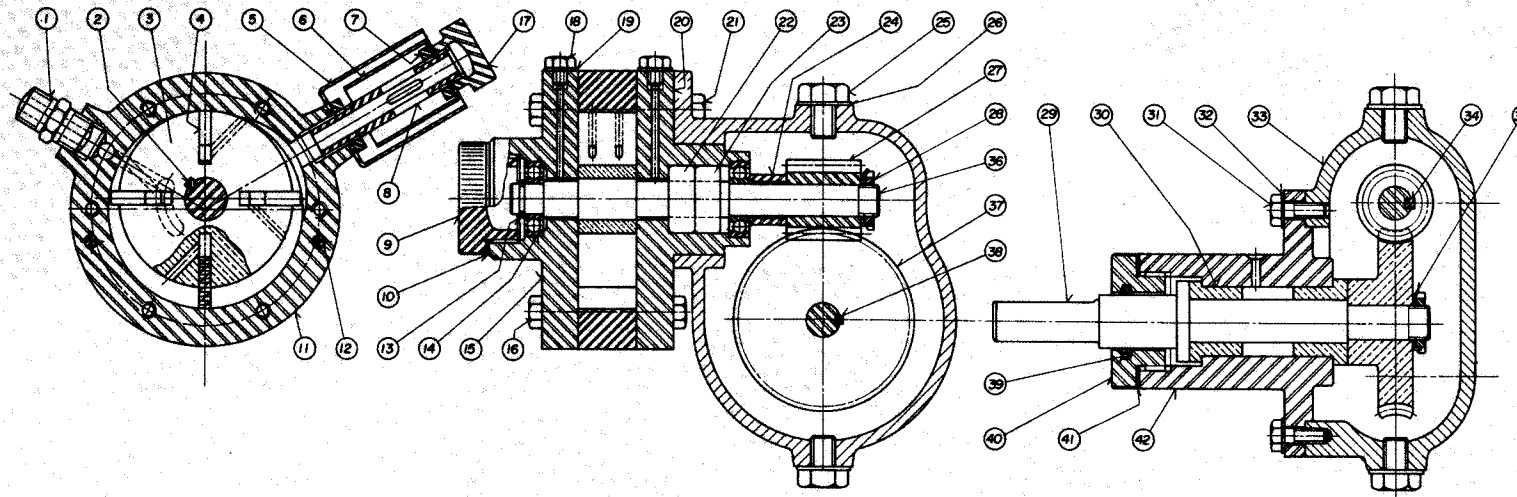

42	Manca!	1	aco 3525 AF	#4" x 73
41	Guarnição	1	couro	#37 x #50 x 1,5
40	Tampa	1	aco NB 1020	#2" x 21
39	Anel de Nitro	1	SKF-F15	#20 x #31 x 3,5
38	Chaveta	1	aco NB 1020	3/16" x 4 x 24
37	Corbo	1	bronzes SAE 680	#5" x 24,5
36	Eixo	1	Villares VT-38	#5/8" x 140
35	Arruela de segurança	2	SKF-MB1	#10,5 x #25 x 1
34	Chaveta de ajuste fixo	1	aco NB 1020	3/16" x 4 x 28
33	Caixa	1	ferro fundido	ver detalhes
32	Guarnição	4	couro	#1/4" x #13 x 1,5
31	Parafuso de cob. sext.	4	---	#1/4"-20 x 5/8"
30	Bucha	2	bronzes SAE 680	#1 1/2" x 20
29	Eixo	1	Villares VT-38	#1 1/2" x 167

28	Porca de fixação	2	SKF-KM1X	#12 x #22 x 4
27	Rôca sem-fim	1	Villares VT-38	#1 1/4" x 28
26	Guarnição	2	couro	#3/8" x #20 x 1,5
25	Parafuso de cob. sext.	2	---	#3/8"-16 x 1/2"
24	Anel distancador	1	aco NB 1020	#3/4" x 14
23	Retentor de óleo	1	---	#1/2" x #1" x 3/8"
22	Retentor de ar	1	---	#1/2" x #1" x 3/8"
21	Parafuso de cob. sext.	4	---	#1/4"-20 x 1 1/4"
20	Tampa interna	1	aco 3525 AF	2" x #100
19	Guarnição	2	couro	#1/4" x #13 x 1,5
18	Parafuso de cob. sext.	2	---	#1/4" x 3/8"
17	Tampa do silenciador	1	aco NB 1020	#1 1/2" x 15
16	Parafuso de cob. sext.	8	---	#1/4"-20 x 7/8"
15	Tampa externa	1	aco 3525 AF	1 1/2" x #100
14	Rolamento fixo	2	SKF 6001 X	#12 x #28 x 8

13	Anel elástico	1	---	DAe #12
12	Pino	2	ferro treilhado	#3/16" x 50
11	Anel	1	aco 3525 AF	1" x #125
10	Guarnição	1	couro	#33 x #40 x 1,5
9	Tampa	1	ferro fundido	#1 3/8" x 21
8	Canô do silenciador	1	ferro	#1/2" x 60
7	Porca leve	2	ferro	#1/8" gds
6	Capô interno do silenciador	1	chapa preto B.G.16	ver detalhes
5	Capô externo do silenciador	1	chapa preto B.G.16	ver detalhes
4	Palheta	4	celoron	3/16" x 22 x 19
3	Retor	1	bronzes SAE 680	#3" x 22
2	Chaveta de ajuste fixo	1	aco NB 1020	3/16" x 4 x 20
1	Niple	1	bronzes SAE 40	#1/4" gds
ITEM	Denominações	Quant.	Material e dimensões	

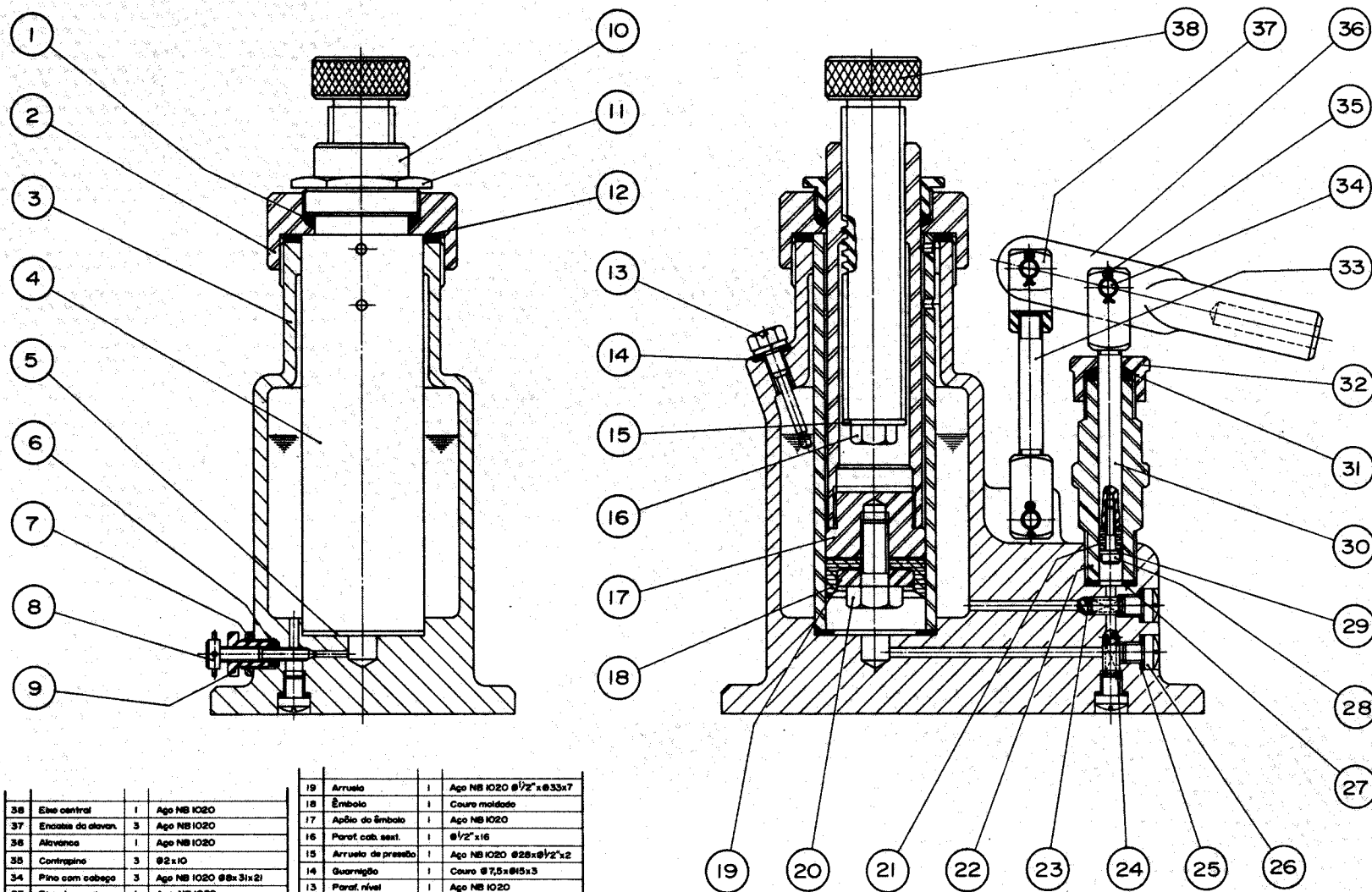

38	Eixo central	1	Aço NB 1020	19	Arruela	1	Aço NB 1020 $\frac{1}{2}$ " x ϕ 33x7
37	Encosta do elevan.	3	Aço NB 1020	18	Êmbolo	1	Couro moldado
36	Alavanca	1	Aço NB 1020	17	Apêlo do êmbolo	1	Aço NB 1020
35	Contingine	3	ϕ 2 x 10	16	Paraf. cab. sext.	1	$\frac{1}{2}$ " x 16
34	Pino com cabeça	3	Aço NB 1020 ϕ 8 x 3x21	15	Arruela de pressão	1	Aço NB 1020 ϕ 28 x $\frac{1}{2}$ " x 2
33	Eixo do encaste	1	Aço NB 1020	14	Guarnição	1	Couro ϕ 7,5 x ϕ 15 x 3
32	Parca especial	1	Aço NB 1020	13	Paraf. nível	1	Aço NB 1020
31	Guarnição	1	Estopo anelada	12	Guarnição	1	Couro ϕ 50 x ϕ 65 x 3
30	Eixo injeror	1	Aço NB 1020 ϕ 10 x 95	11	Parca especial	1	Aço NB 1020 M50 x 1,5
29	Arruela lisa	1	ϕ 3/16"	10	Espiga	1	Aço NB 1030 ϕ 40 x 162
28	Paraf. "ALLEN"	1	ϕ 3/16" x 8	9	Paraf. da agulha	1	Aço NB 1020 $\frac{1}{2}$ " x 18
27	Guarnição	1	Couro ϕ 10 x ϕ 22 x 3	8	Agulha	1	Aço NB 1030
26	Paraf. cab. red.	4	ϕ 5/8" x 6	7	Parca trava	1	Aço NB 1020 $\frac{1}{2}$ " x 4
25	Guarnição	4	Couro ϕ 7,5 x ϕ 15 x 2	6	Guarnição	1	Couro ϕ 4 x ϕ 10 x 5
24	Mola (5 espiras)	2	$\frac{1}{4}$ " x 15 anela $\frac{1}{16}$ "	5	Guarnição	1	Couro ϕ 35 x ϕ 50 x 2,5
23	Estere	2	SKF $\frac{1}{4}$ "	4	Carreta	1	Aço NB 1030
22	Luzo do pistão	1	Aço NB 1030	3	Carca	1	Ferro fundido
21	Gaxeta	1	Couro ϕ 3/16" x ϕ 10 x 10	2	Parca especial	1	Aço NB 1020
20	Paraf. cab. sext.	1	$\frac{1}{2}$ " x 75	1	Guarnição	1	Estopo anelada
				Nº	DENOMINAÇÕES		MATERIAL E DIMENSÕES

MACACO HIDRÁULICO

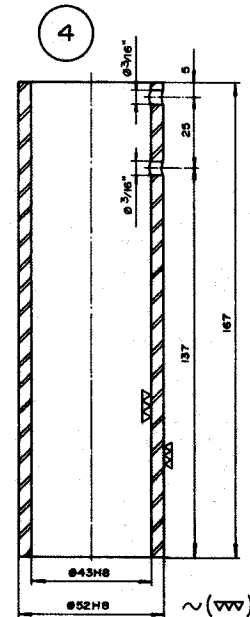
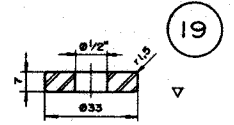
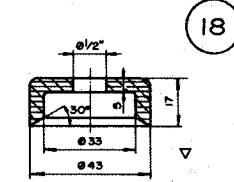
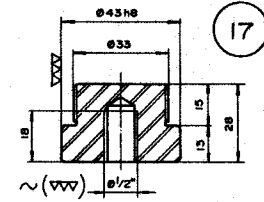
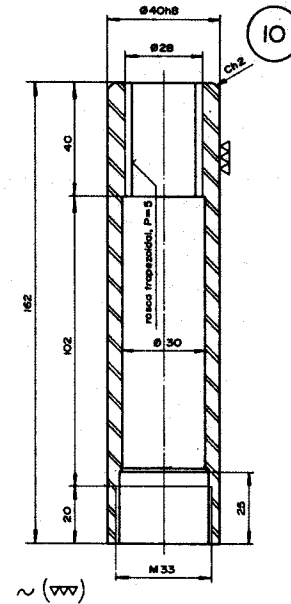
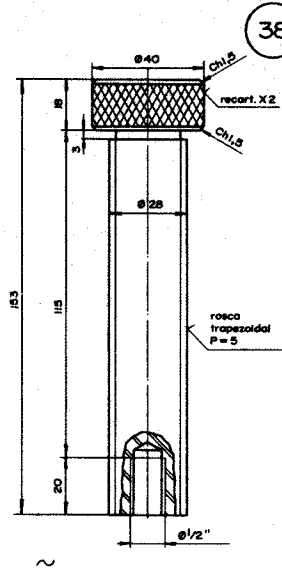
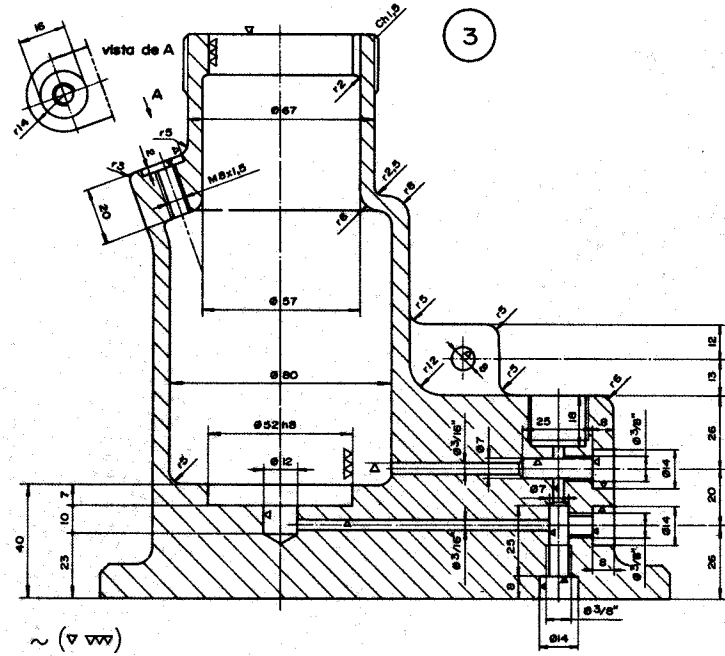
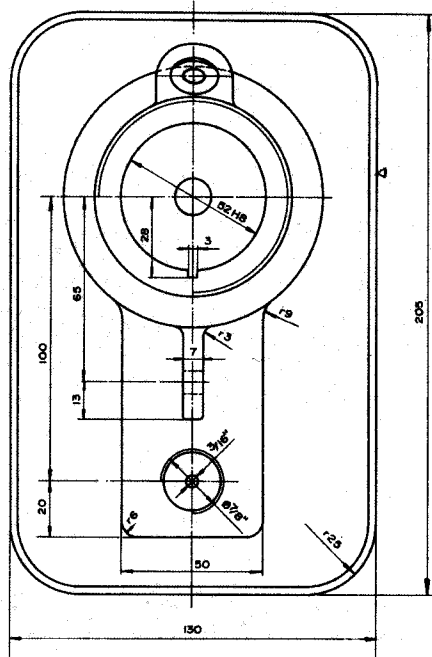
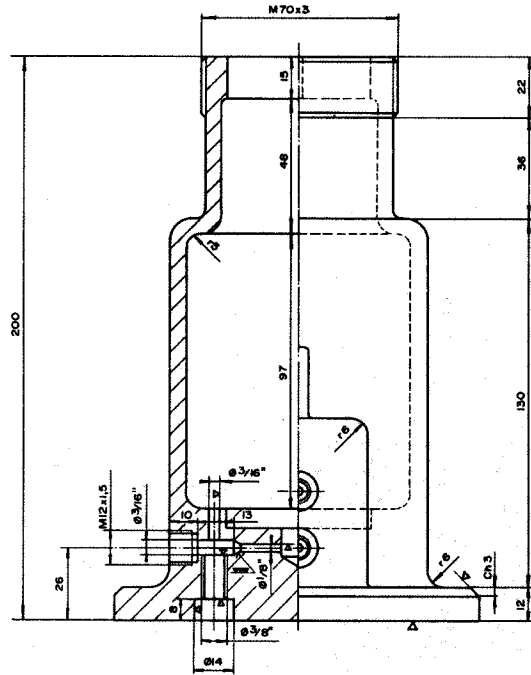

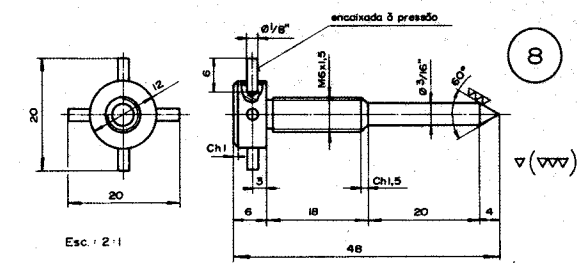
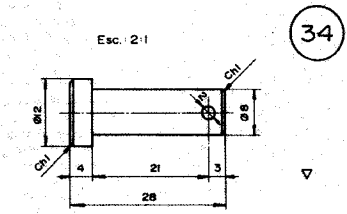
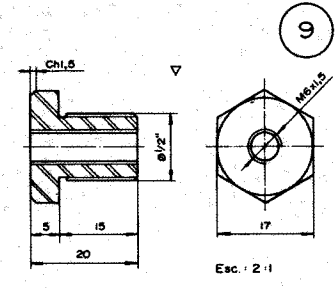
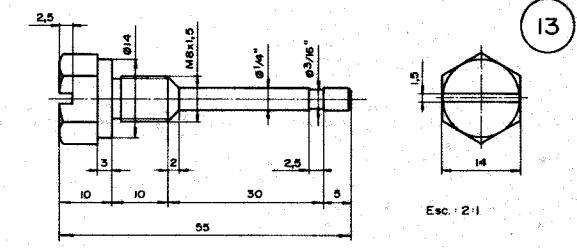
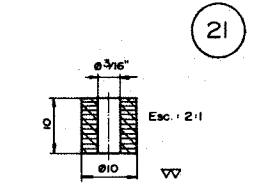
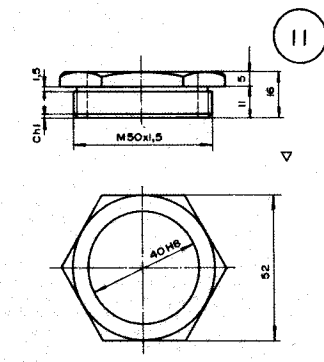
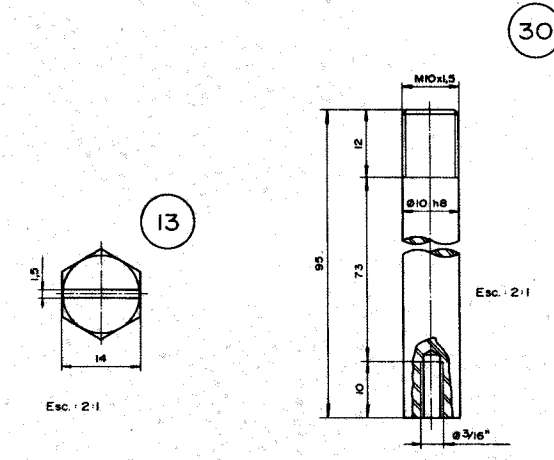
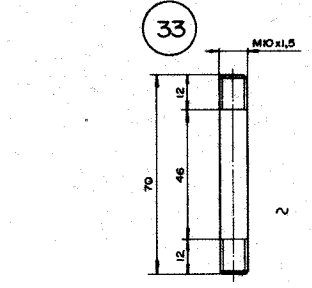
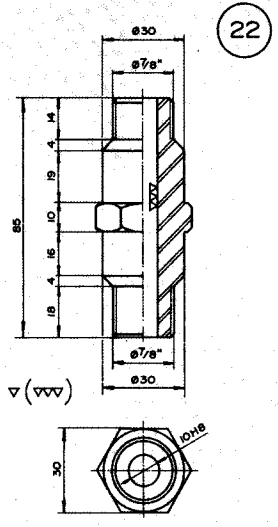
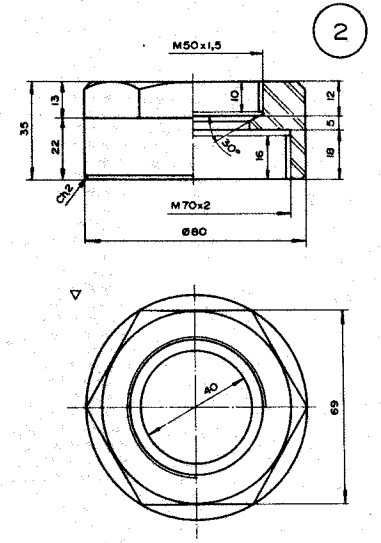
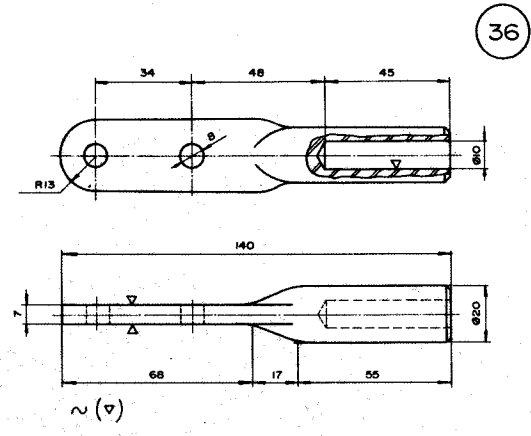
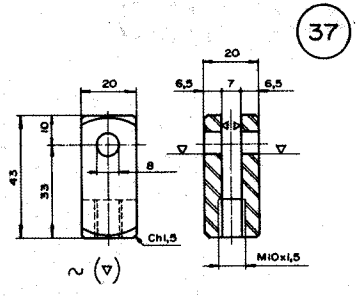
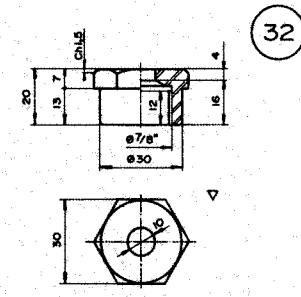

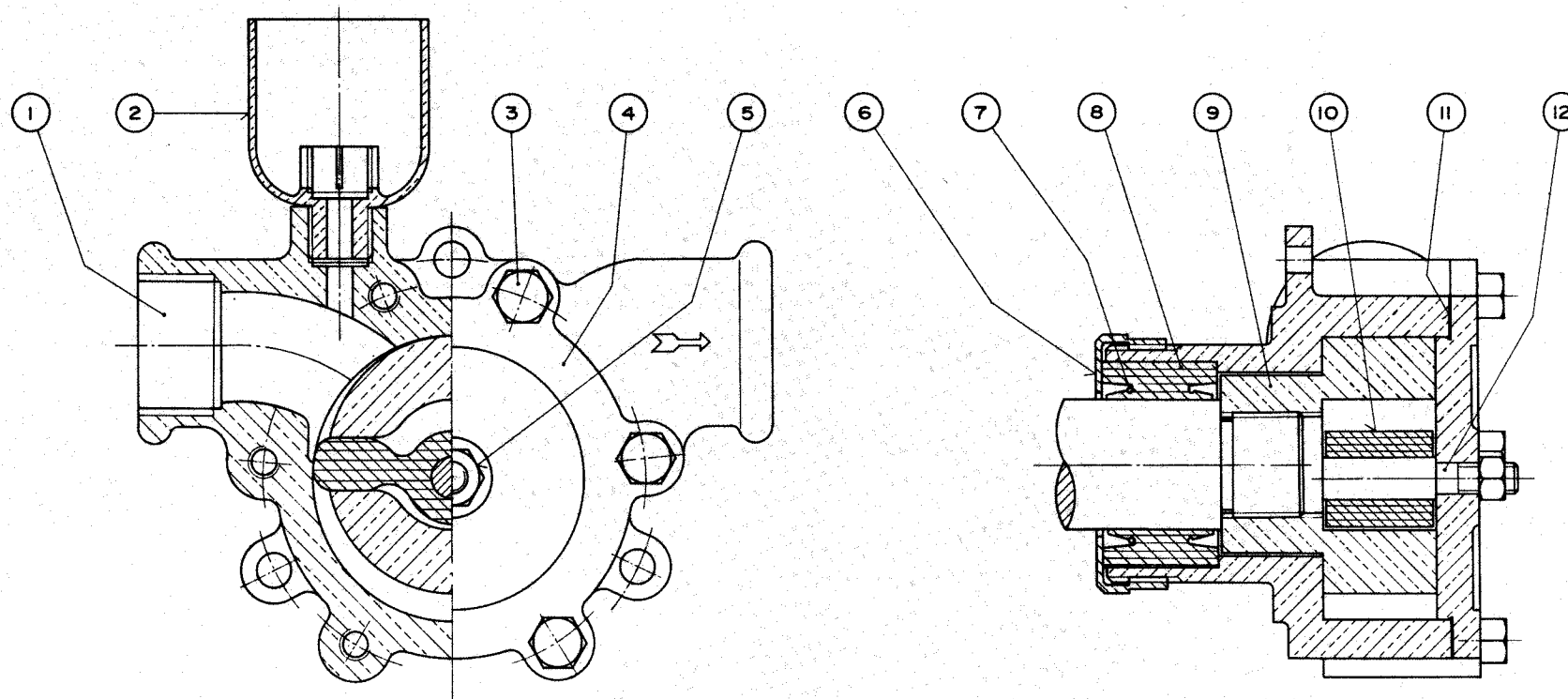

BOMBA DE ÁGUA

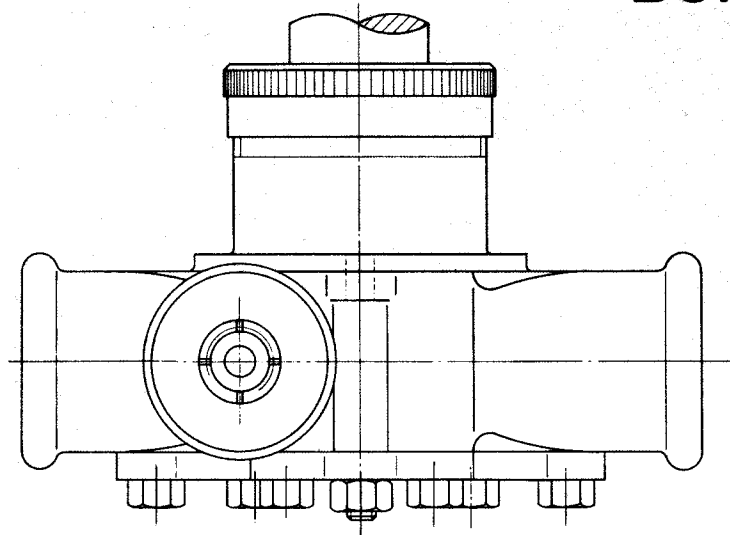

12	Eixo	1	Aço NB 1030 Ø8x37
11	Guarnição	1	Papel Ø55xØ70x1
10	Palheta	1	Celaron
9	Gua da palheta	1	Latão
8	Retentor	1	Borracha Ø40xØ25x22
7	Anel do retentor	1	Aço NB 1045 Ø29
6	Porca especial	1	Latão
5	Porca sextavada	1	M6
4	Tampa	1	Latão
3	Paraf. cob. sext.	6	M5x15
2	Copinho	1	Latão
1	Carcaga	1	Latão
Item	DENOMINAÇÕES	Quant.	MATERIAL E DIMENSÕES

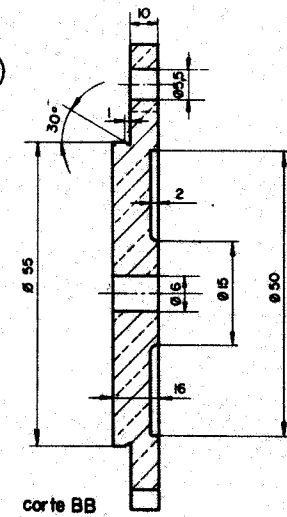
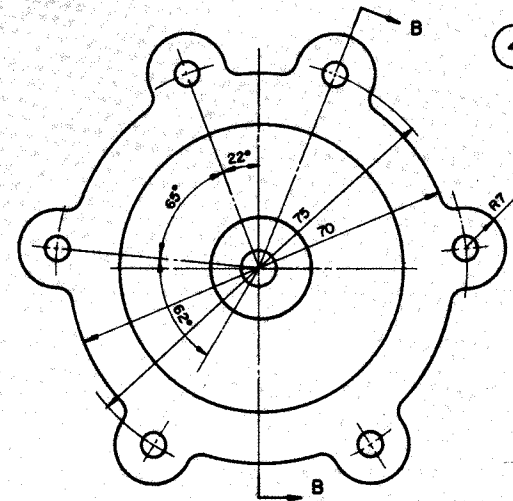
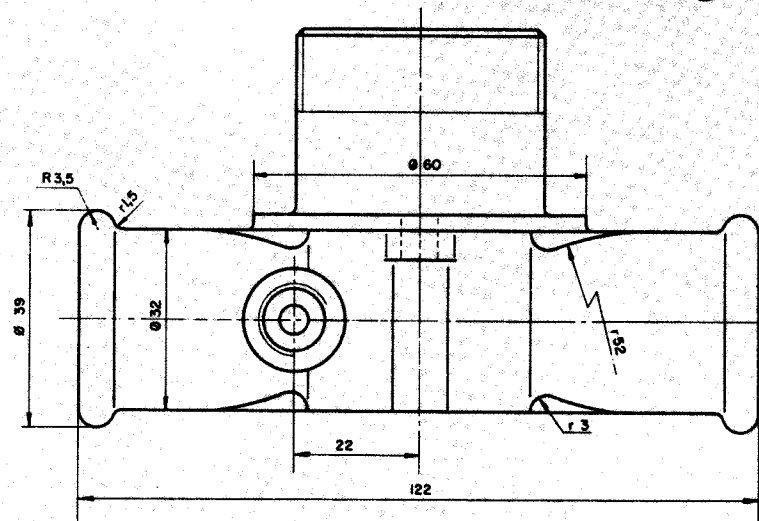
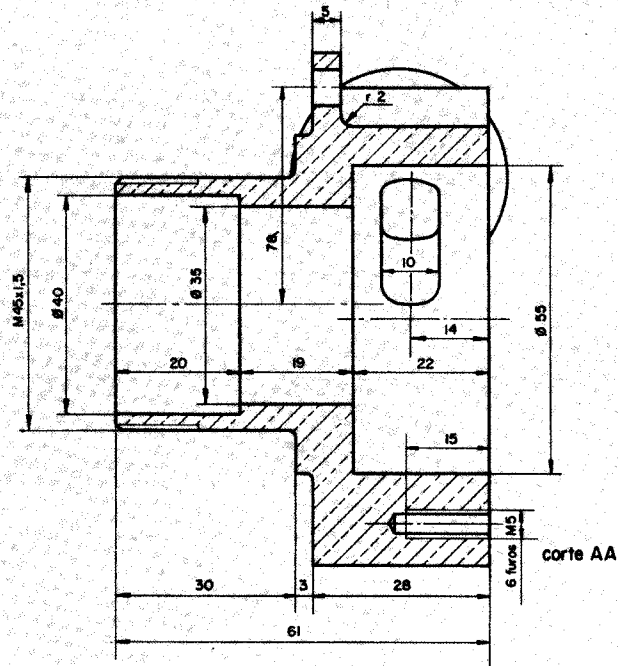
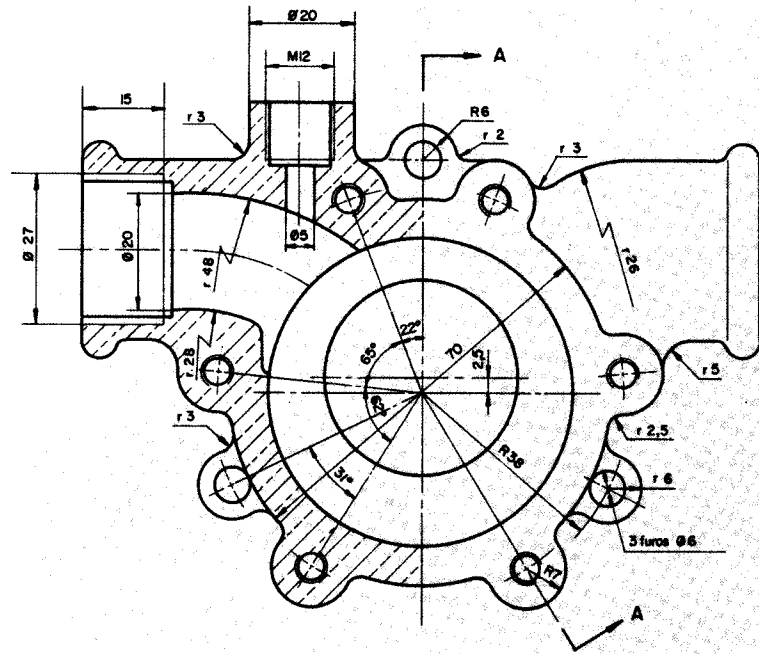

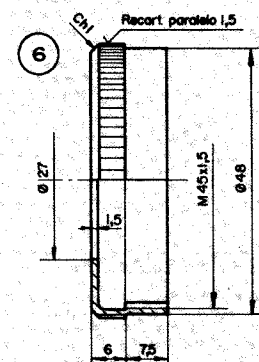
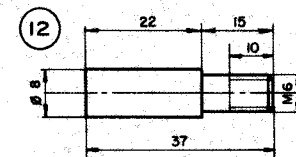
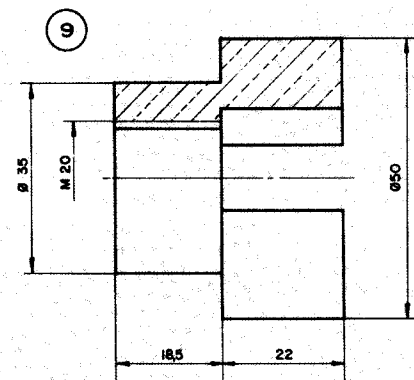
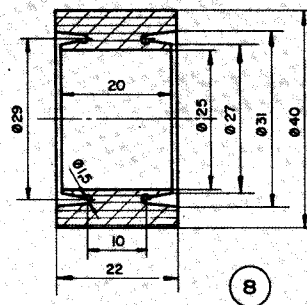
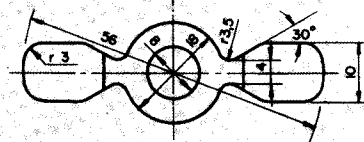
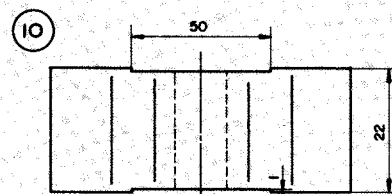
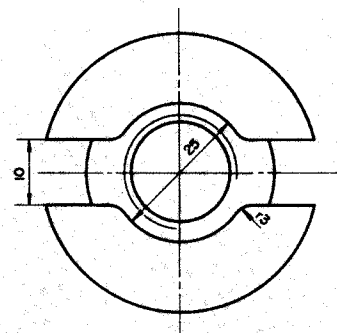
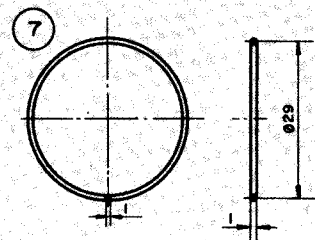
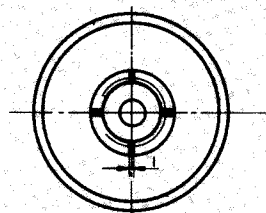
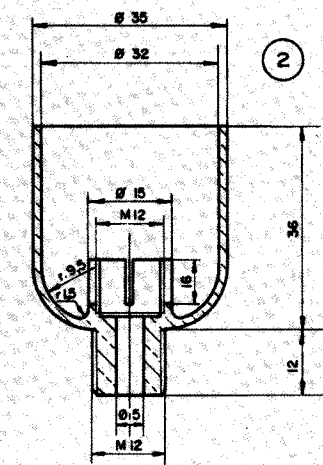

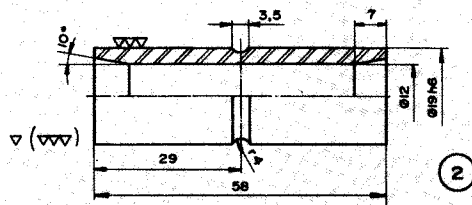
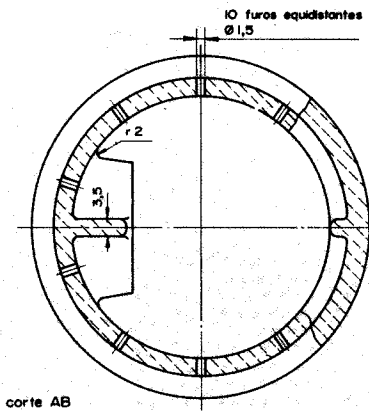
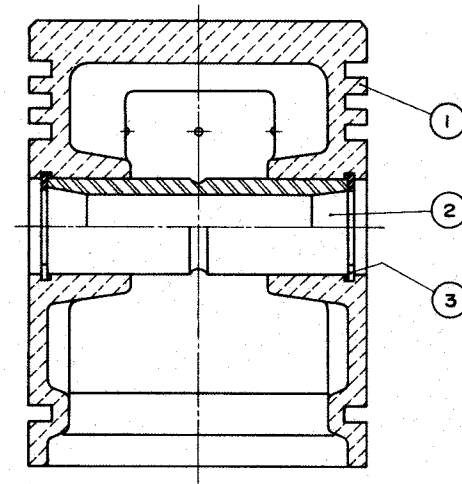
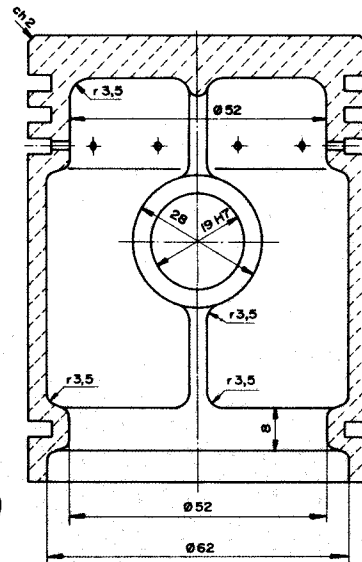
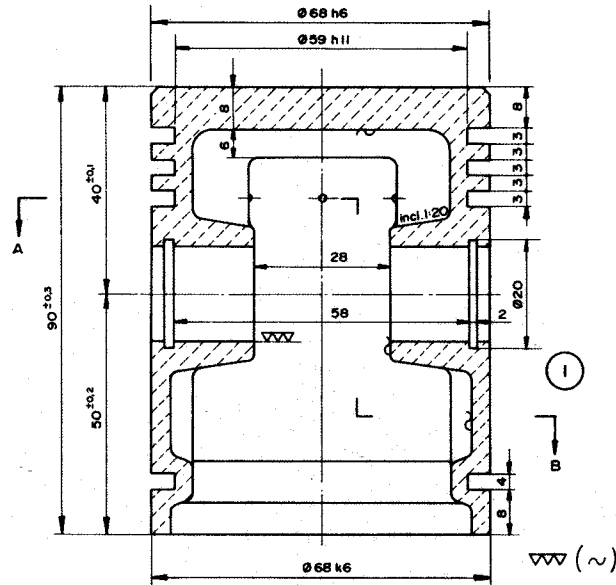

PISTÃO

Nº	DENOMINAÇÕES	Quant.	MATERIAL E DIMENSÕES
3	Anel elástico	2	DAI Ø 19 (DANIEL ABRAHAM, S.P)
2	Pino	1	Aço NB 1030 Ø 19 x 58
1	Pistão	1	Alumínio Ø 68 x 90

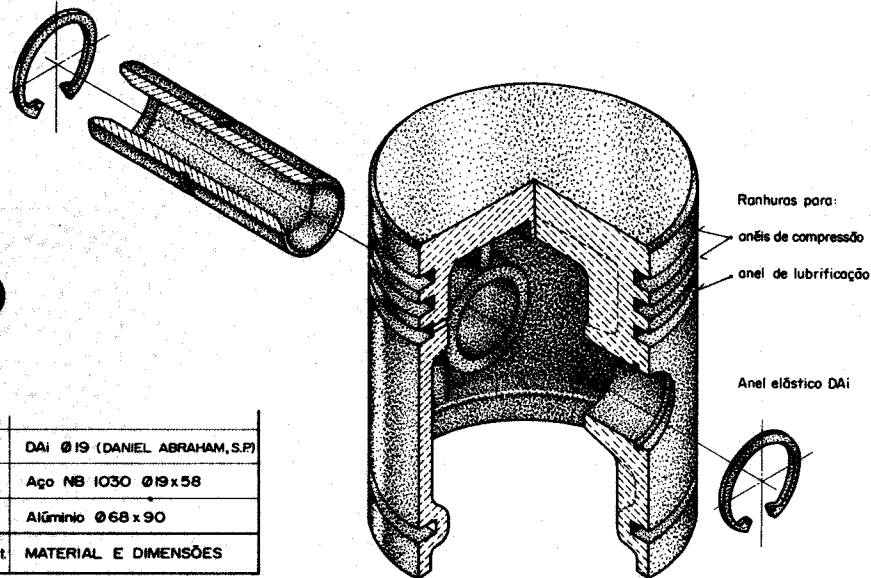

PISTÃO

PARA MOTOR DE 4 TEMPOS, CILINDRO DE 68mm DE DIÂMETRO, CURSO DE 75mm E 8,5 CV POR CILINDRO A 4500 R.P.M.

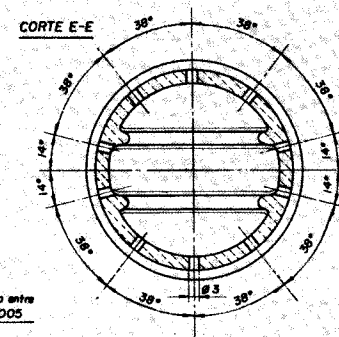
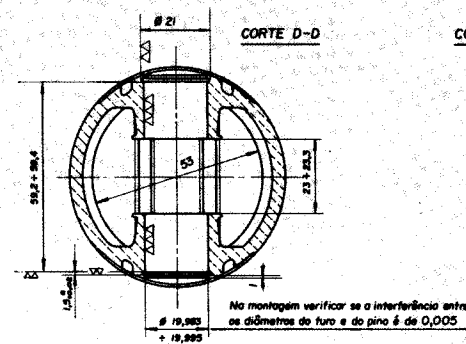
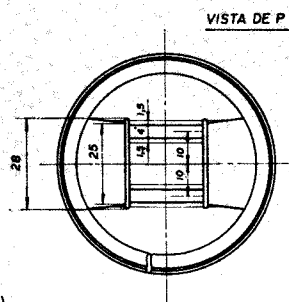
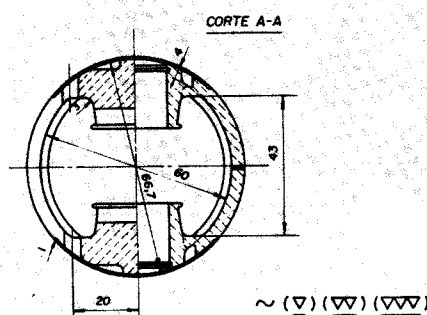
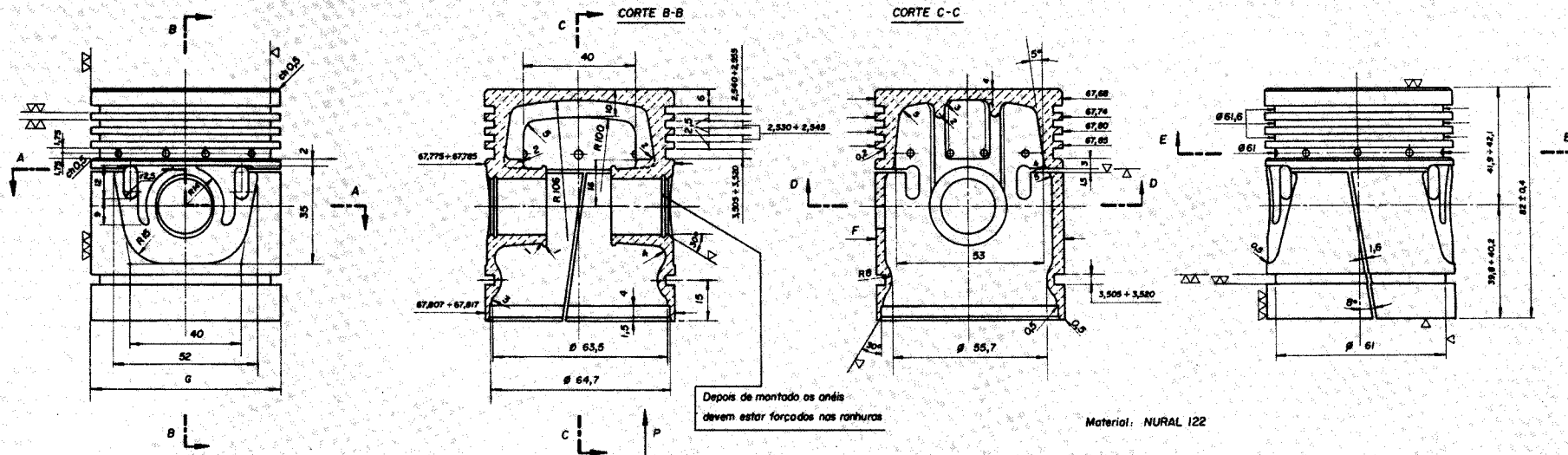

Estampar no pistão a letra A, B ou C, segundo a tolerância usada.

G	A: 67,967 + 67,977	F	A: 67,935 + 67,945
	B: 67,977 + 67,987		B: 67,945 + 67,955
	C: 67,987 + 67,997		C: 67,955 + 67,965

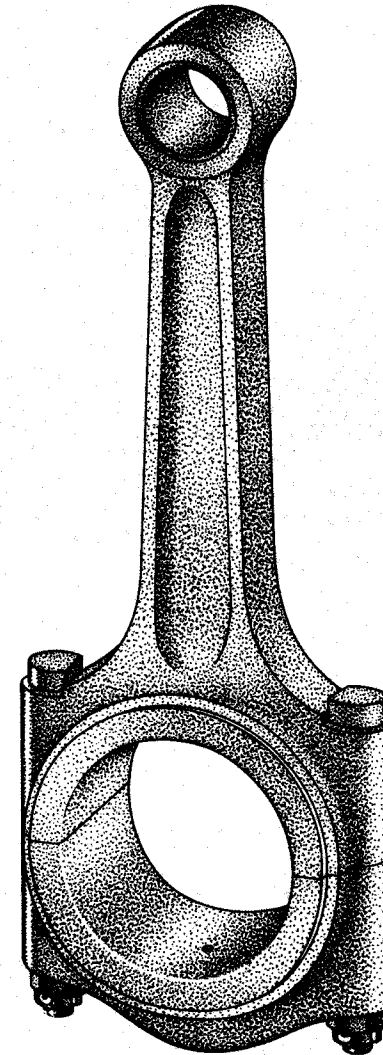
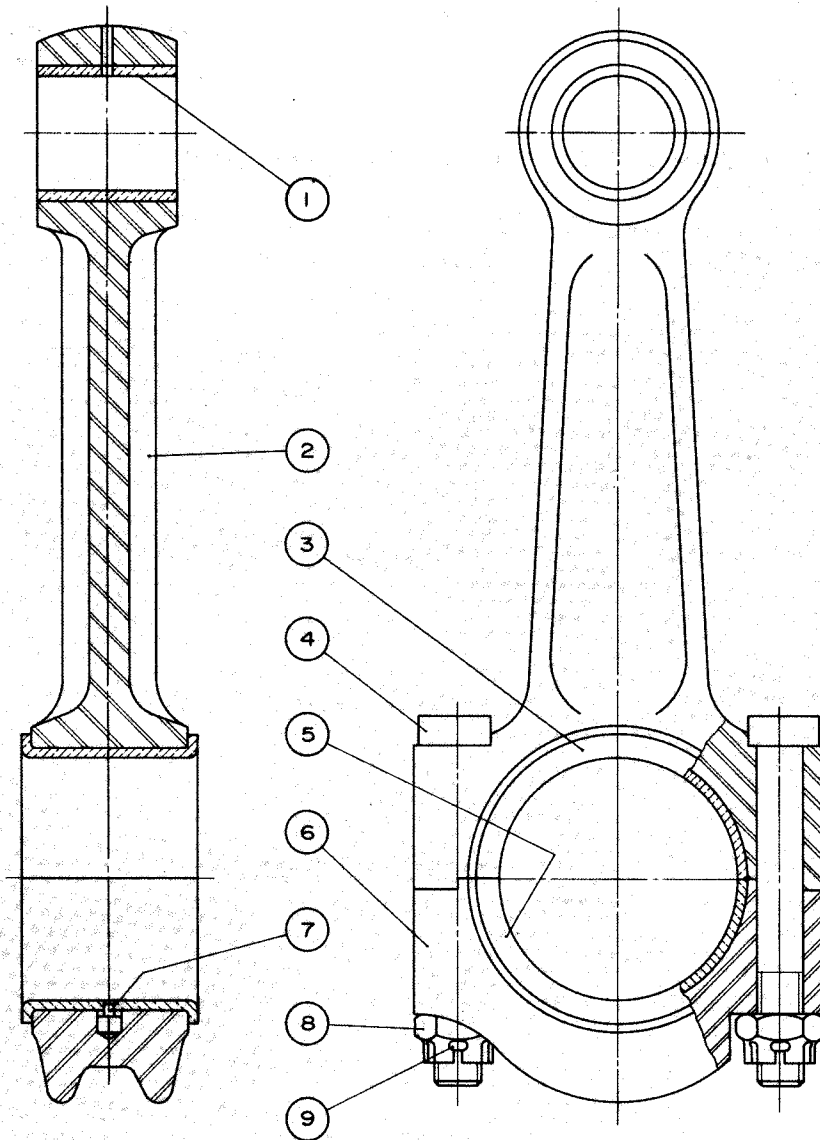

BIELA

9	Cupilha	2	Ø 2 x 28	4	Parafuso	2	Aço NB 1040 M8x57
8	Porco castelo	2	Aço NB 1040 M8	3	Casoilho superior	1	Bronze SAE 660
7	Pino do bronzino	1	Aço NB 1020	2	Haste	1	Aço NB 1040
6	Tampa	1	Aço NB 1040	1	Bucho	1	Bronze SAE 660
5	Casoilho inferior	1	Bronze SAE 660	Nº	DENOMINAÇÕES	Quant.	MATERIAL E DIMENSÕES

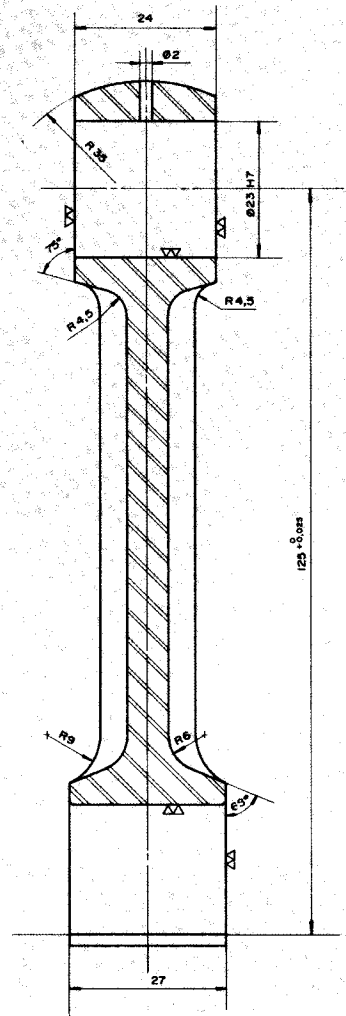

~ (∇, ∇∇)

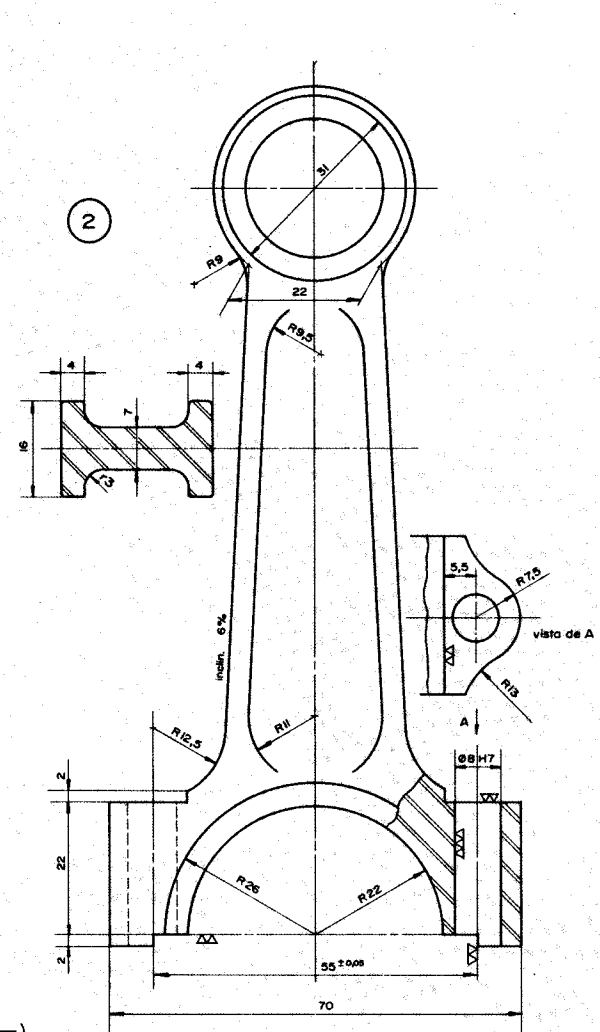

2

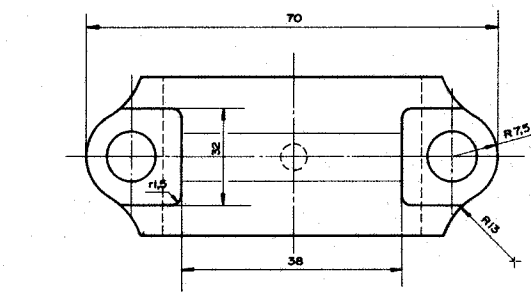

6

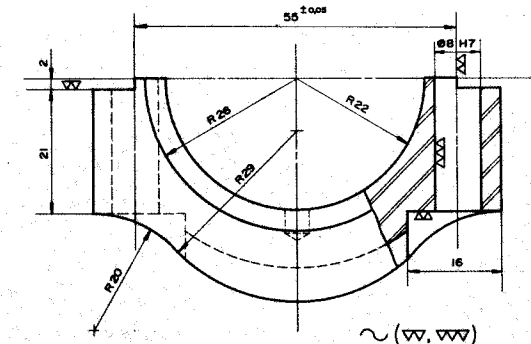

~ (∇, ∇∇)

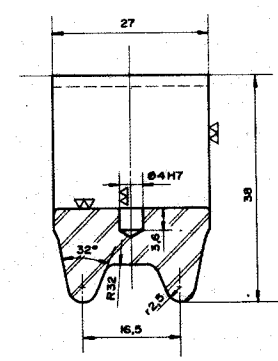

5

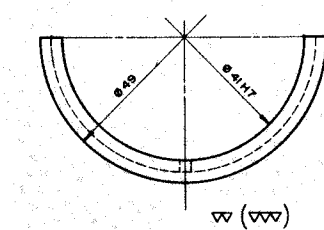
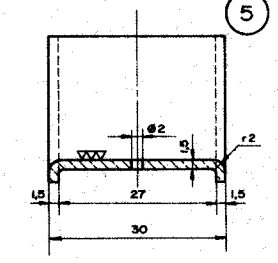

∇ (∇∇)

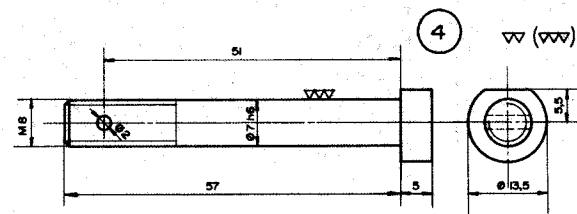

4

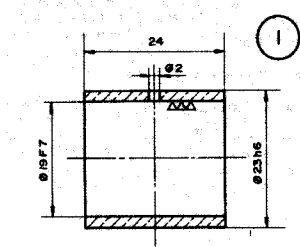

1

∇ (∇∇)

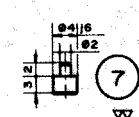

7

A peça nº 3 será análoga à nº 5 porém sem o furo de Ø2.

3

BIELA

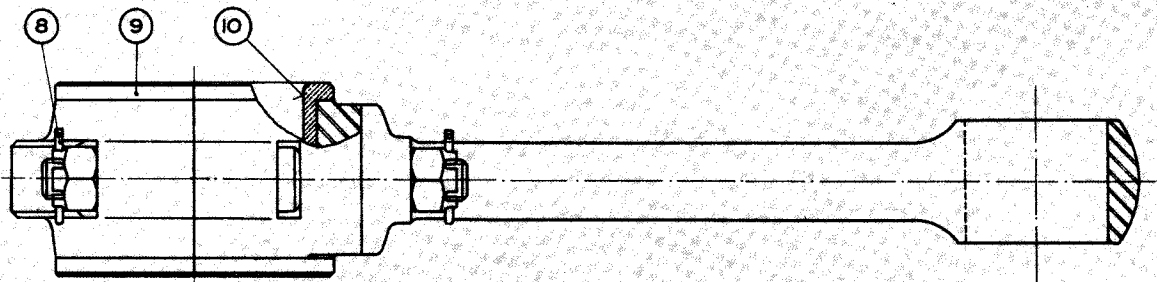
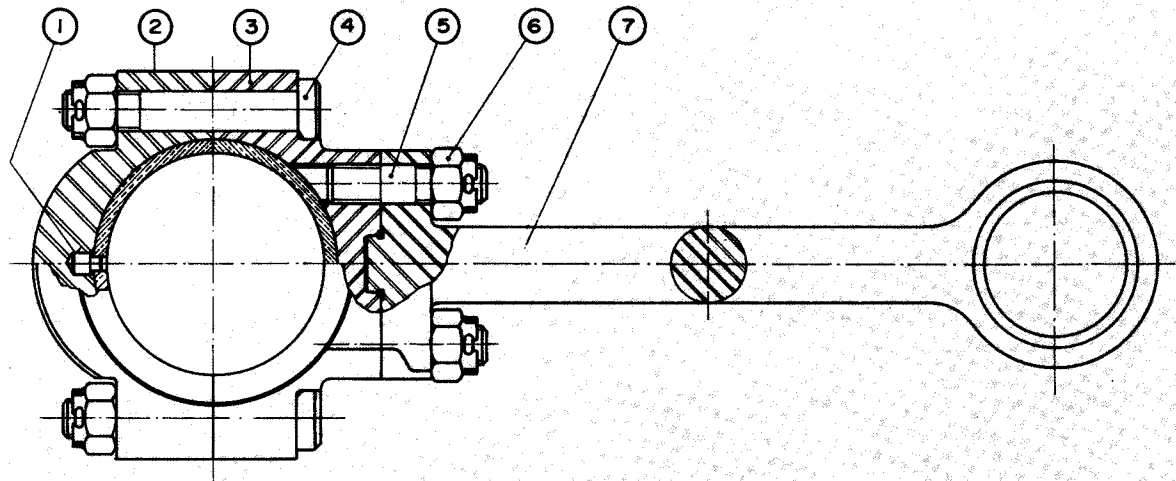

10	Bronzina da cabeça	1	Bronze SAE 660
9	Bronzina da tampa	1	Bronze SAE 660
8	Contrapino	4	Aço NB 1040 Ø3x35
7	Haste	1	Aço NB 9837
6	Porca castelo	4	Aço NB 1040 M14x1,5
5	Prisioneiro	2	Aço NB 1040 M14x1,5x55
4	Parafuso da tampa	2	Aço NB 1040
3	Cabeça	1	Aço NB 9837
2	Tampa	1	Aço NB 9837
1	Pino da bronzina	1	Aço NB 1040
Nº	DENOMINAÇÕES	Quant.	MATERIAL E DIMENSÕES

VIRABREQUIM

MOTOR DE AUTOMÓVEL DE QUATRO CILINDROS, 35 CV E 4500 RPM.

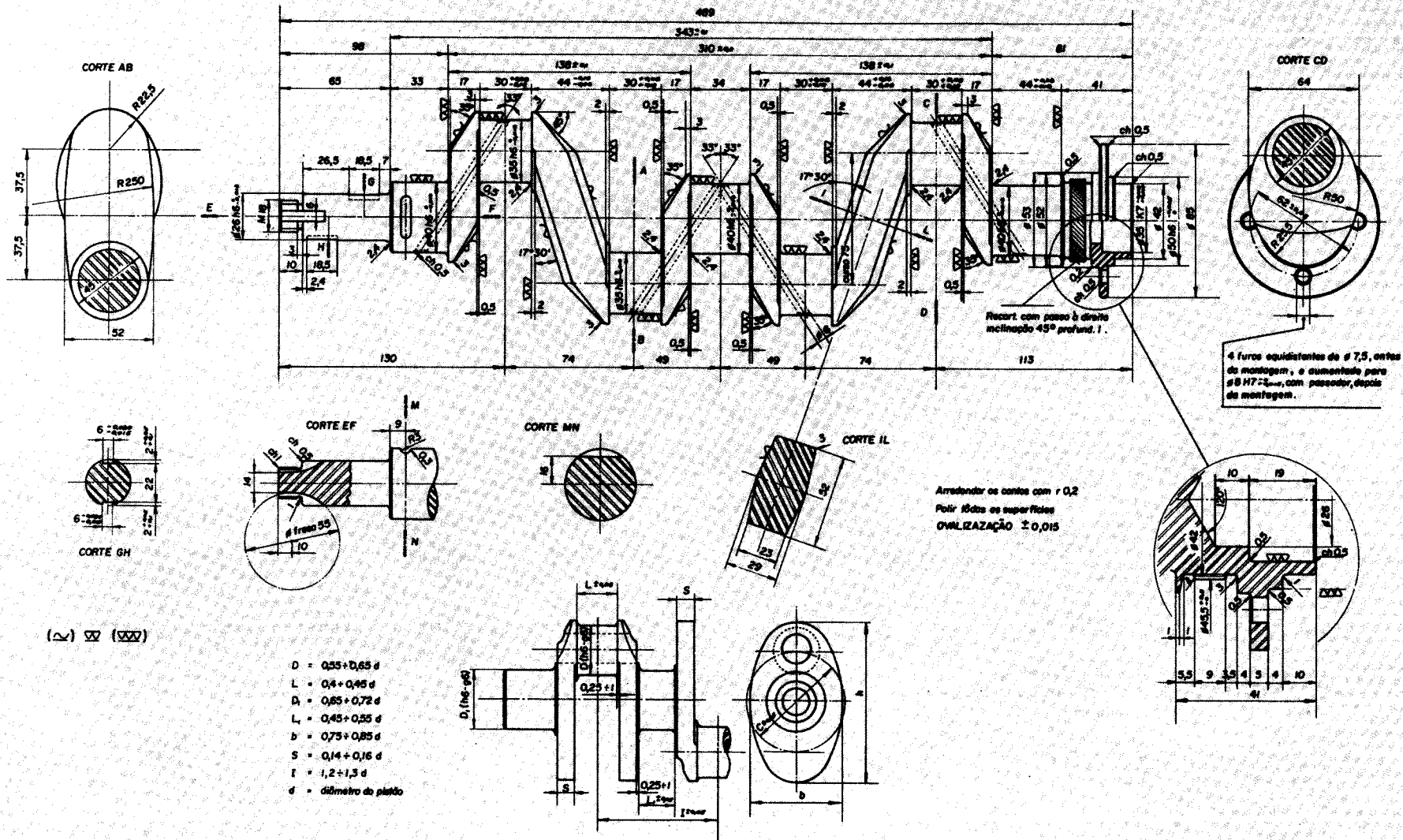

VIRABREQUIM DE MOTOR EM LINHA COM DOIS SUPORTES POR CILINDRO

VIRABREQUIM

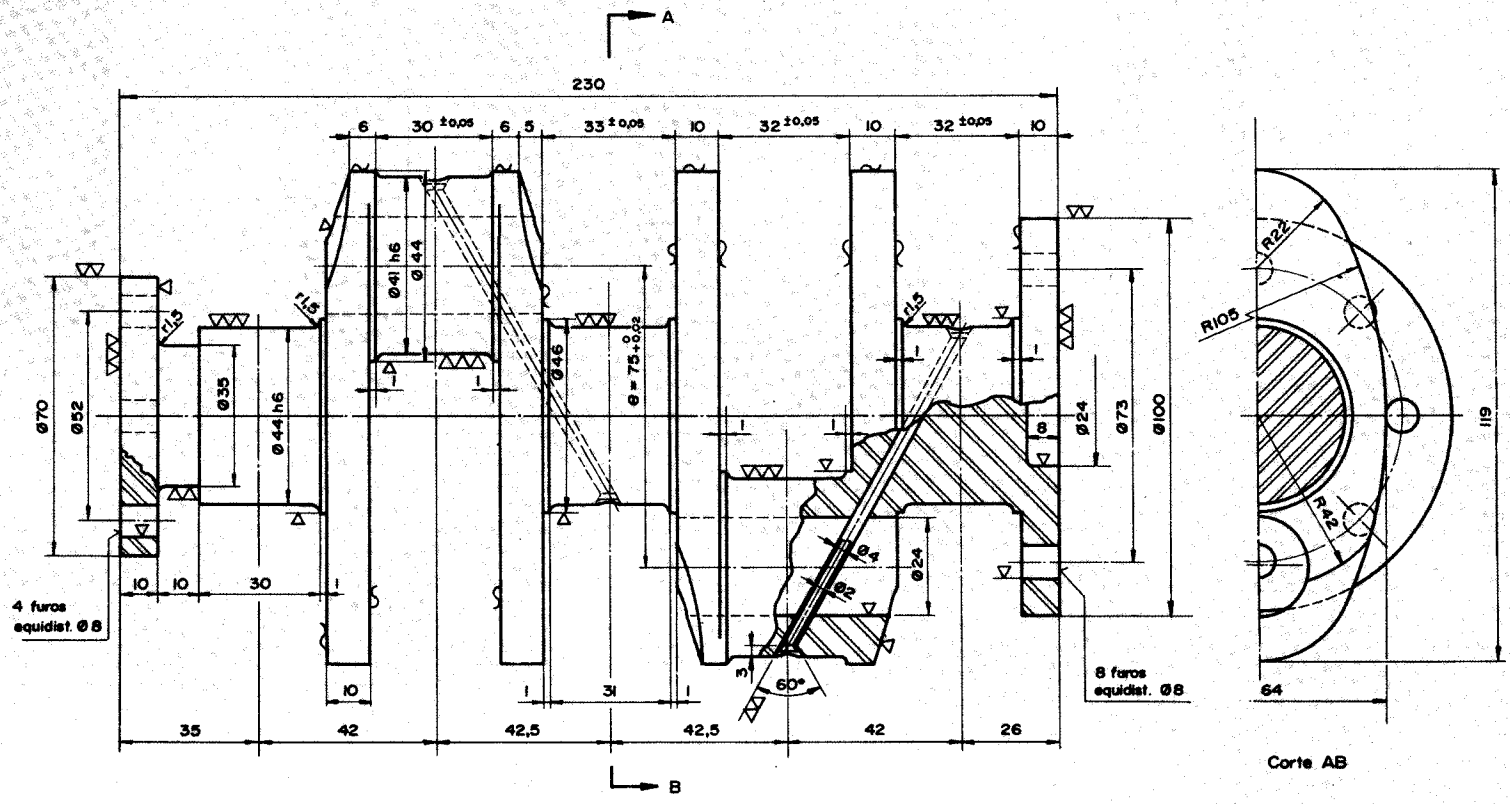
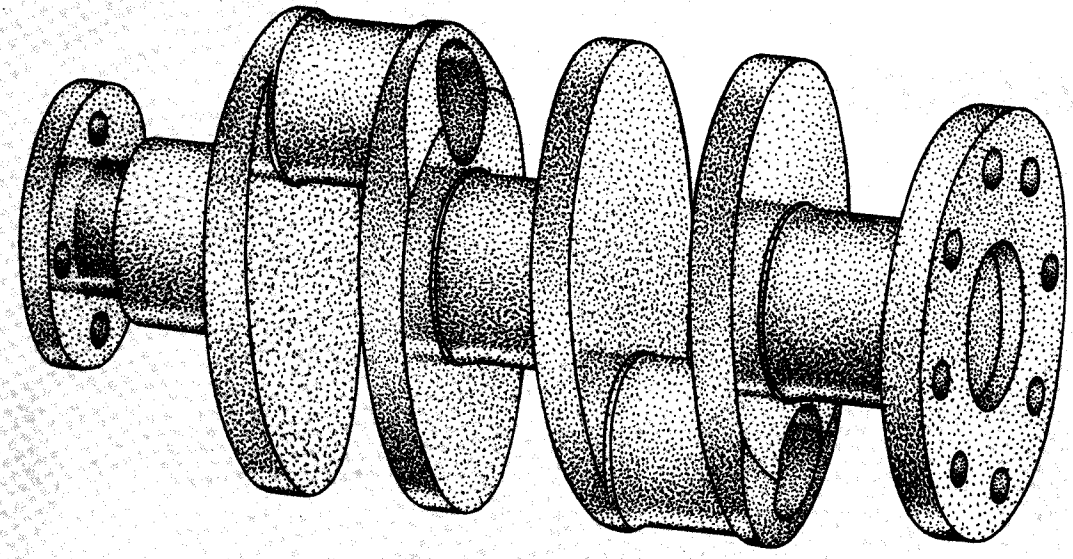

TUCHO PARA VÁLVULA

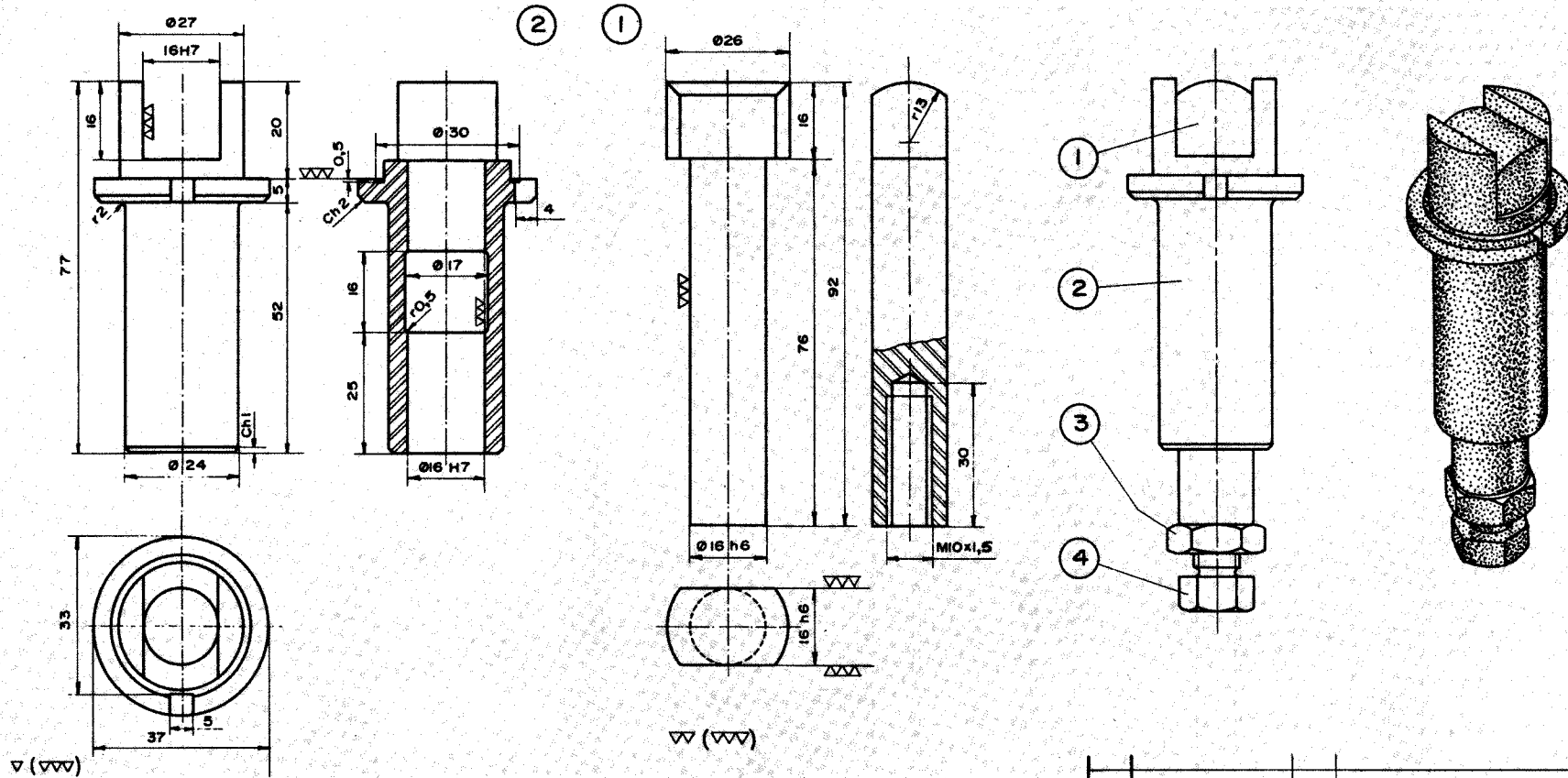

4	Paraf. cab. sext.	1	M10x1,5 x24
3	Porca sext.	1	M10x1,5
2	Bucha	1	Aço NB 1060
1	Haste	1	Aço NB 1060
Item	DENOMINAÇÕES	Quant.	MATERIAL E DIMENSÕES

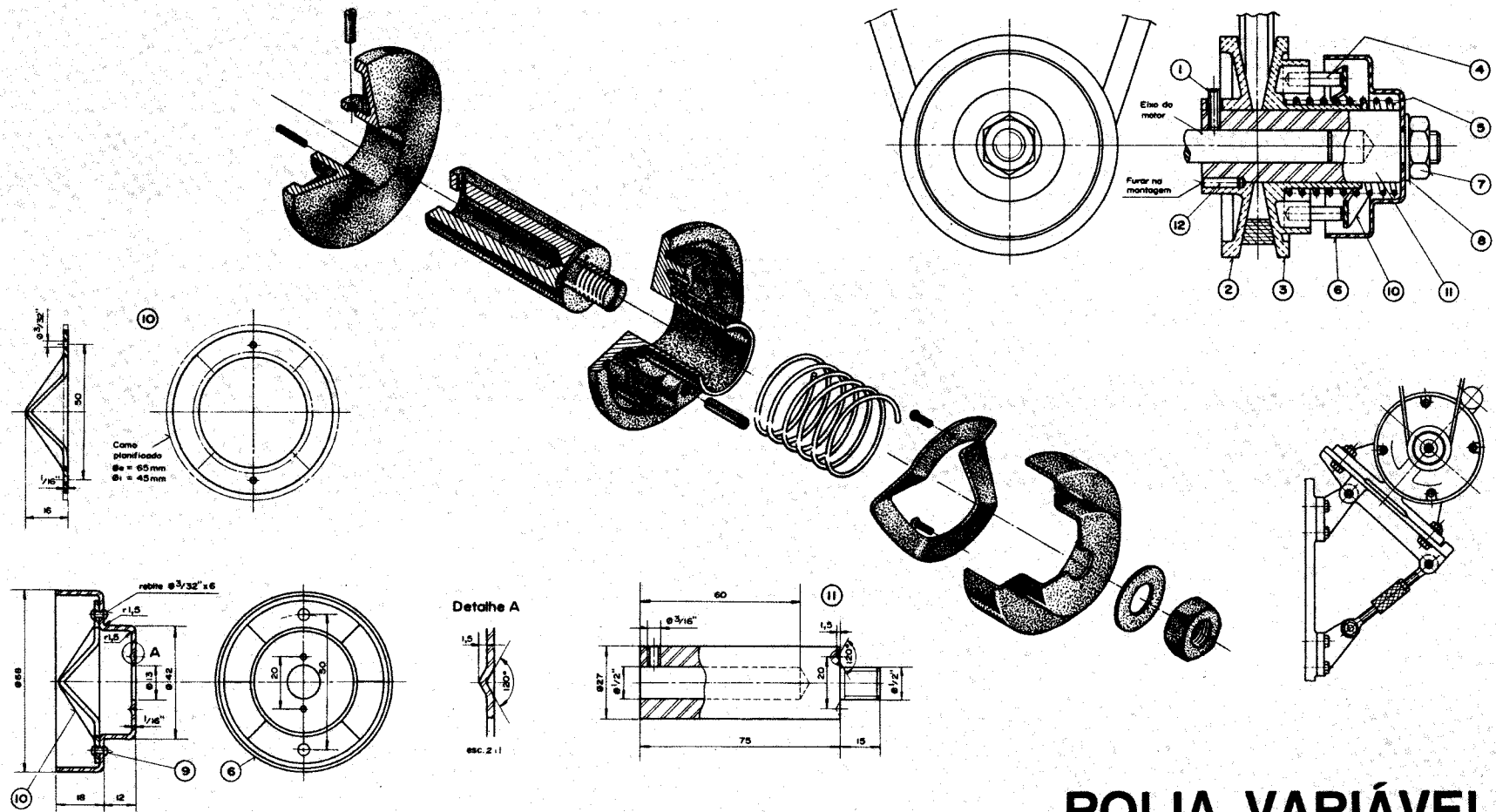

POLIA VARIÁVEL

Nº	DENOMINAÇÕES	Quant.	MATERIAL E DIMENSÕES
12	Pino de fixação	1	Aço prata Ø3x15
11	Eixo	1	Aço NB 1020 Ø27 x 90
10	Como	1	Chapa de aço NB 1010 BG 16
9	Rebite	2	Aço NB 1010 Ø3/32 x 6
8	Arruela	1	Aço NB 1020 Ø13
7	Porca	1	Aço NB 1020 Ø1/2"
6	Proteção	1	Chapa de aço NB 1010 BG 16
5	Mola	1	Aço NB 1070 $\begin{matrix} \sigma = 35 \\ \rho = 5 \\ \nu = 9 \end{matrix}$
4	Pino de madeira	2	Peroba Ø5x20
3	Faca da polia	1	Duralumínio Ø82 x 40
2	Faca da polia	1	Duralumínio Ø82 x 20
1	Paraf. sem cab.	1	Aço NB 1020 Ø3/16" x 15

ESTICADOR DE CORREIA

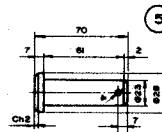
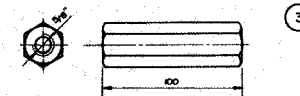
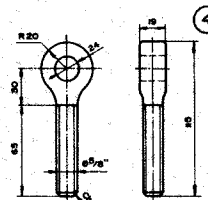
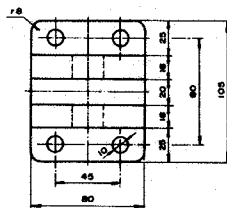
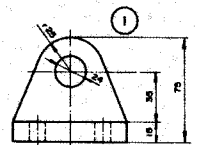
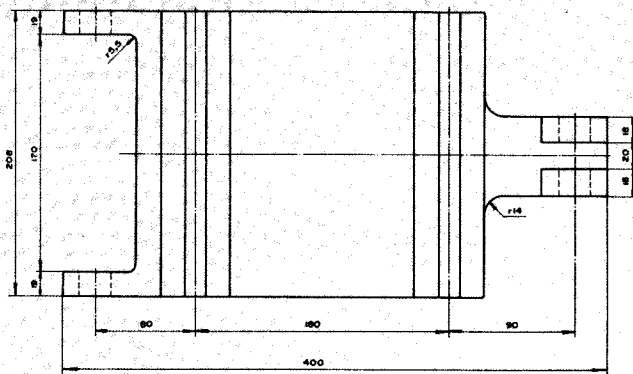
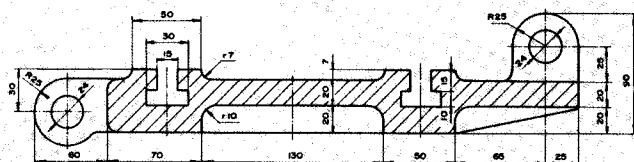
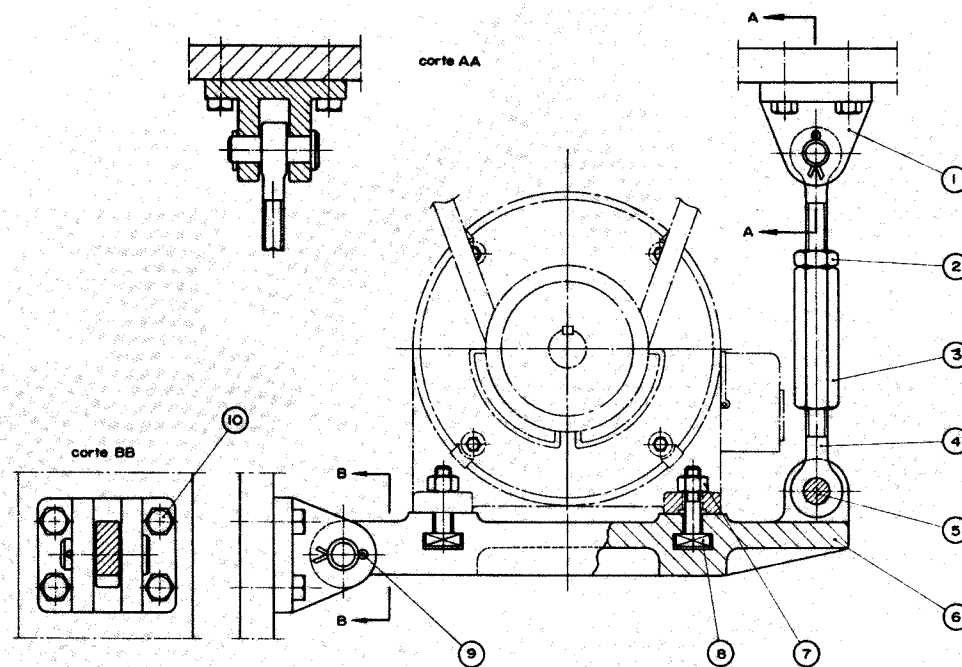
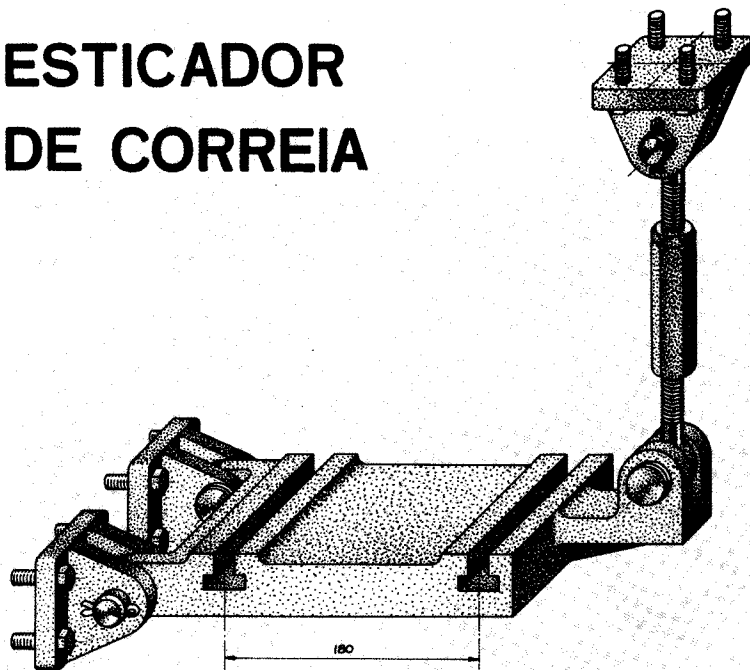

Nº	DENOMINAÇÕES	Quant	MATERIAL E DIMENSÕES
10	Paraf. cab. sext	12	Ø 3/8" x 60
9	Cupilha	4	Ø 4 x 30
8	Paraf. cab. quad.	4	Ø 1/2" x 50
7	Paraf. sext.	4	Ø 1/2" x 10
6	Suporte	1	Ferro fundido
5	Pino com cabeça	4	Aço NB 1020 Ø 23 x 63
4	Paraf. de argola	2	Ø 5/8" x 115
3	Paraf. sext.	1	Aço NB 1020 Ø 5/8" x 100
2	Centro-paraf. sext.	1	Ø 5/8" x 12
1	Articulação	3	Ferro fundido

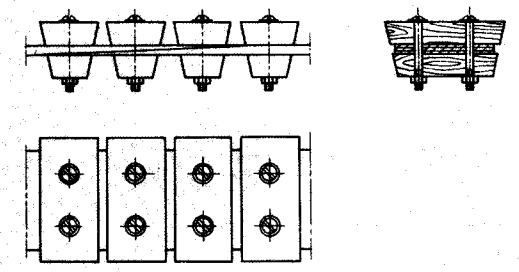
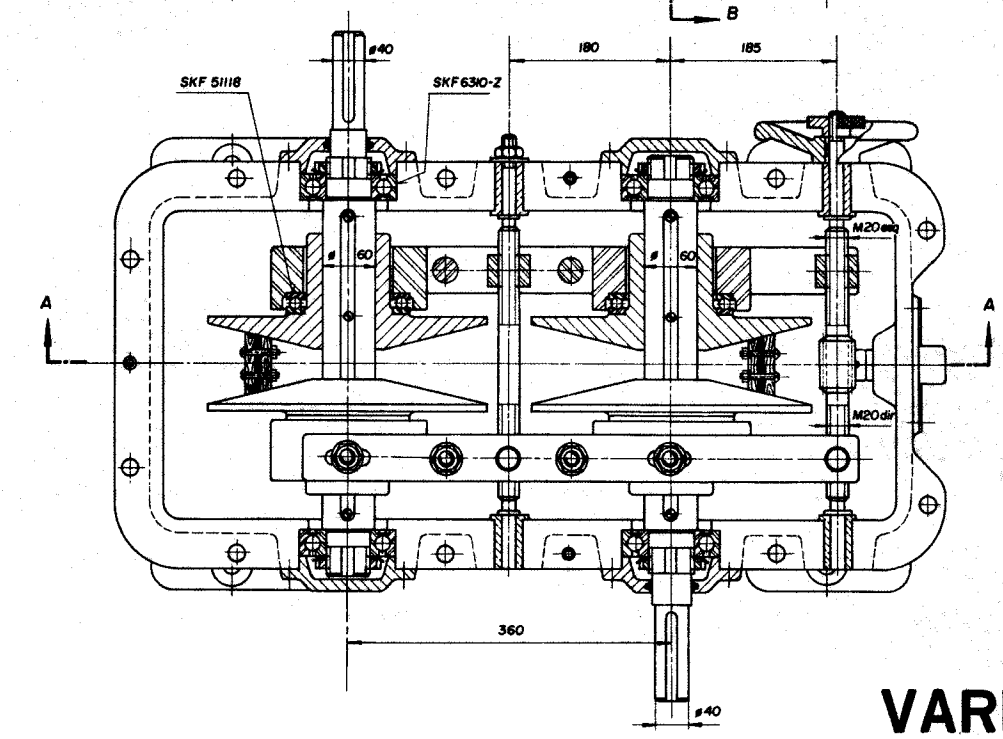
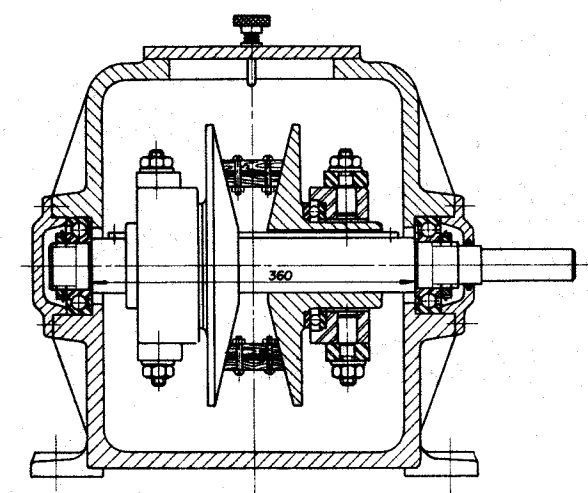
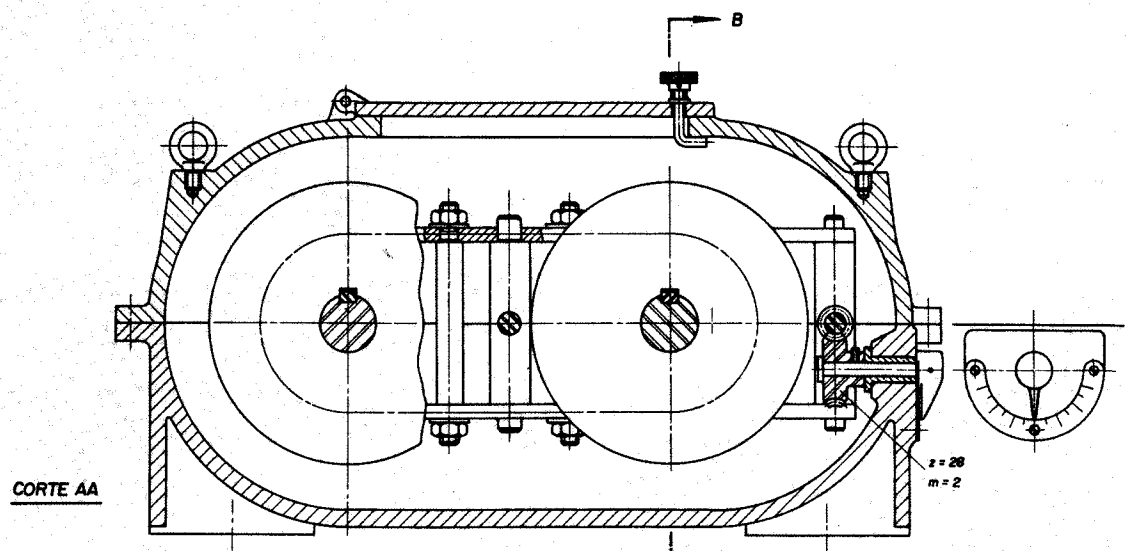

VARIADOR DE VELOCIDADE

VARIADOR DE VELOCIDADE

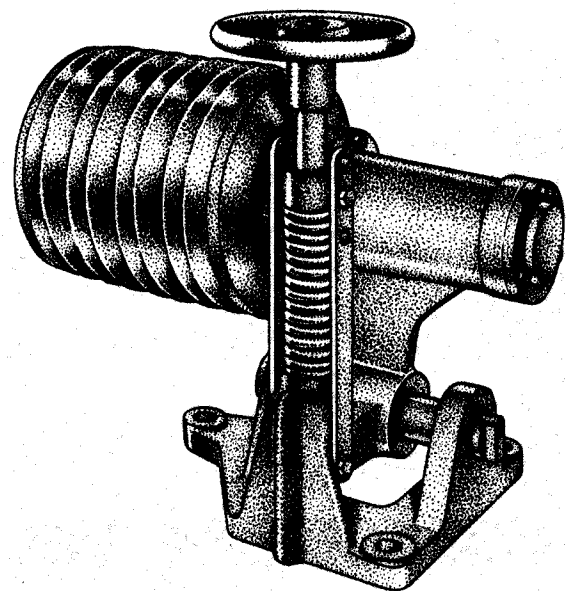
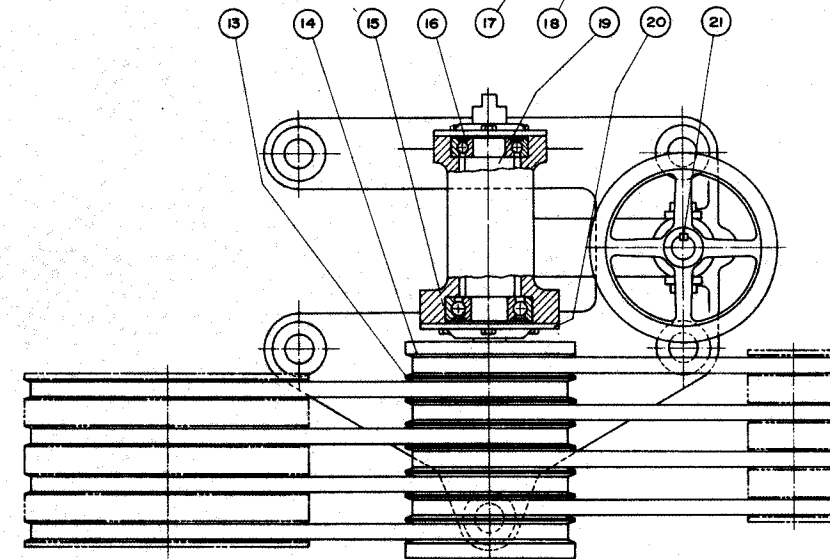
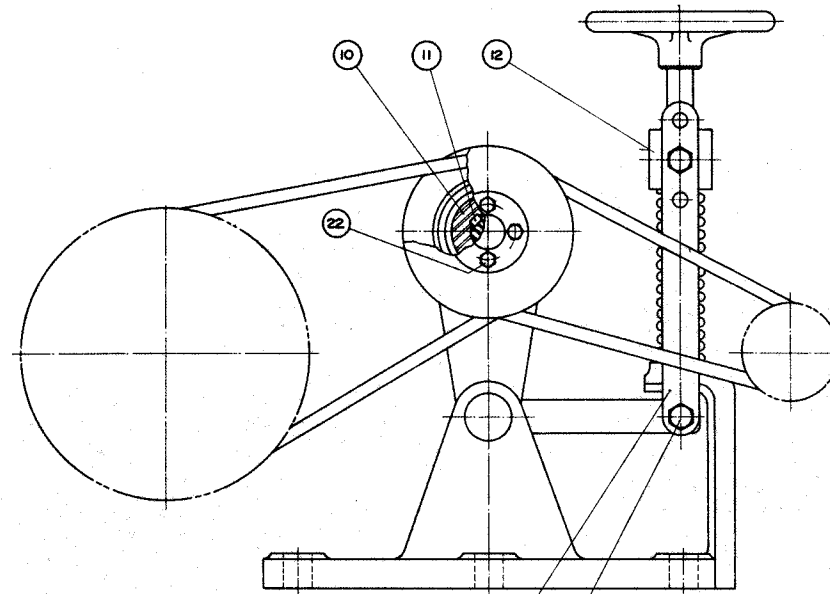
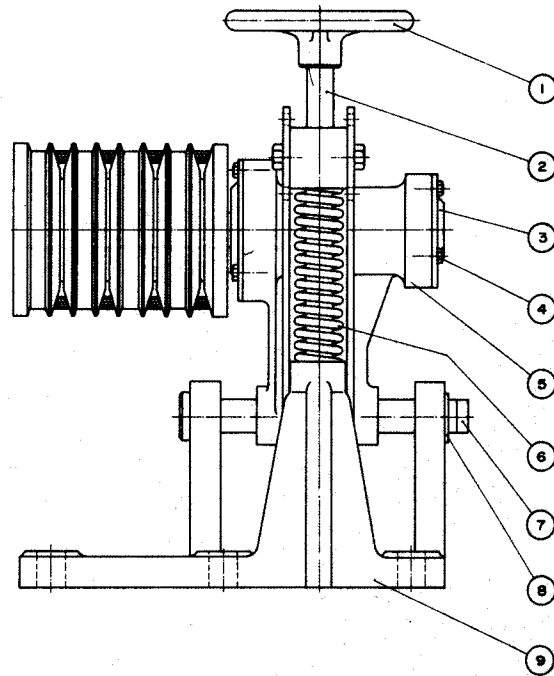

22	Paraf. cab. sext	8	Ø 5/16" x 16
21	Chaveta paralela	1	8x8x25
20	Tampa do rodam	1	Ferro fundido
19	Eixo do polo	1	Aço NB 1020
18	Paraf. cab. sext	1	Ø 1/2" x 14
17	Lateral de este	2	Aço NB 1020
16	Rolamento	1	SKF 6305
15	Rolamento	1	SKF 6306
14	Faca ant. do polo	2	Aço NB 1020
13	Faca int. do polo	7	Aço NB 1020
12	Encosto do mola	1	Aço NB 1020
11	Chaveta paralela	1	8x7x180
10	Bucha	1	Aço NB 1020
9	Corpo fixo	1	Ferro fundido
8	Anel elástico	1	Dile 23
7	Pino	1	Aço NB 1020
6	Mola	1	Aço NB 8450
5	Corpo móvel	1	Ferro fundido
4	Paraf. cab. sext	6	Ø 5/16" x 10
3	Tampa do rodam	1	Ferro fundido
2	Eixo do volante	1	Aço NB 1020
1	Volante	1	Ferro fundido
Nº	DENOMINAÇÕES	MATERIAL E DIMENSÕES	

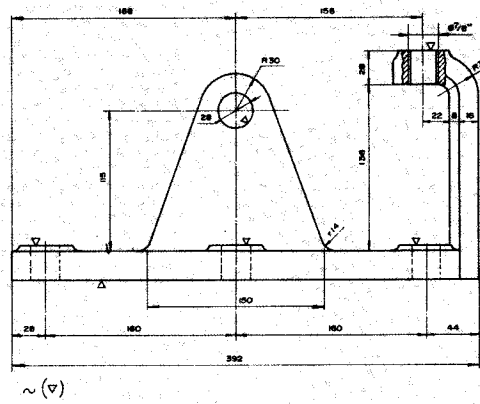

8

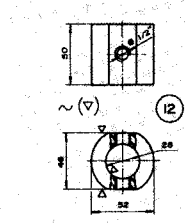
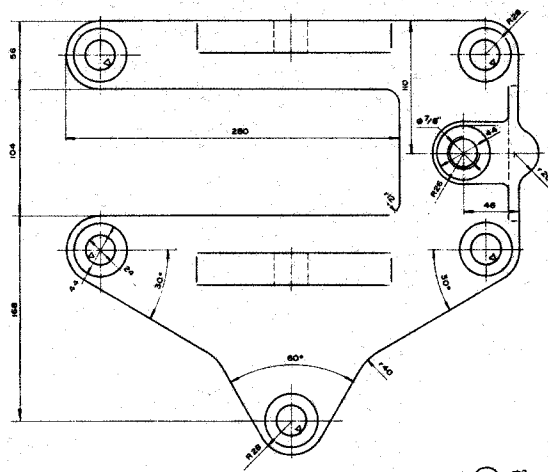
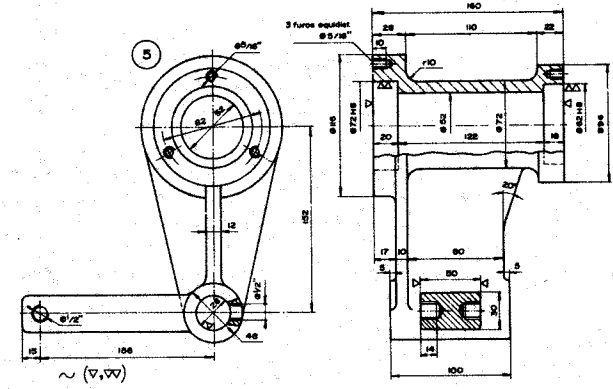
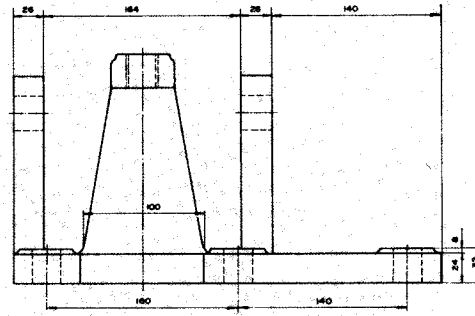

12

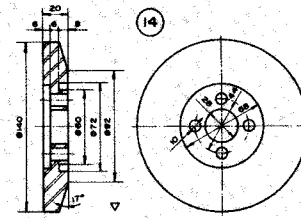

14

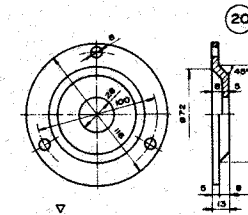

20

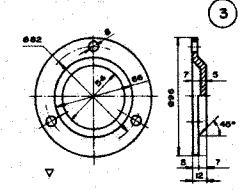

3

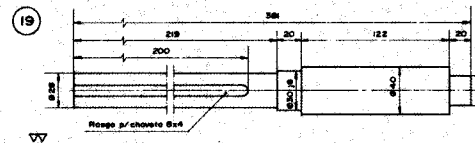

19

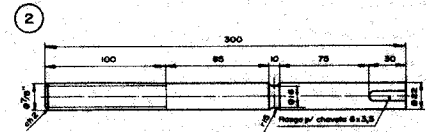

2

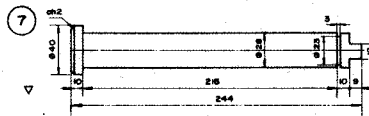

7

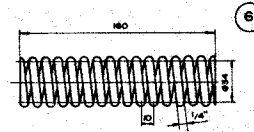

6

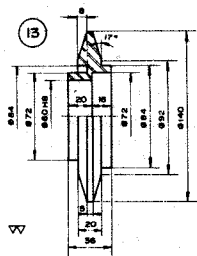

13

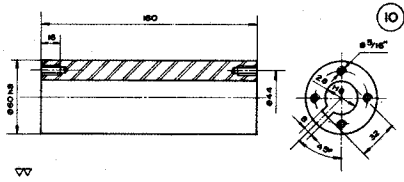

10

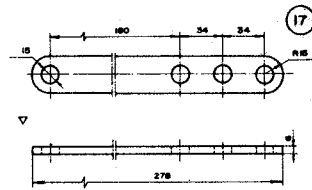

17

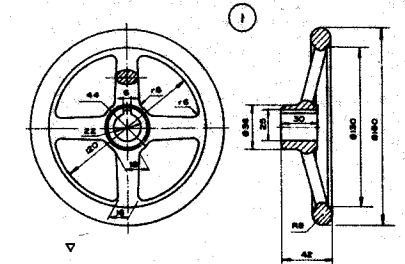

1

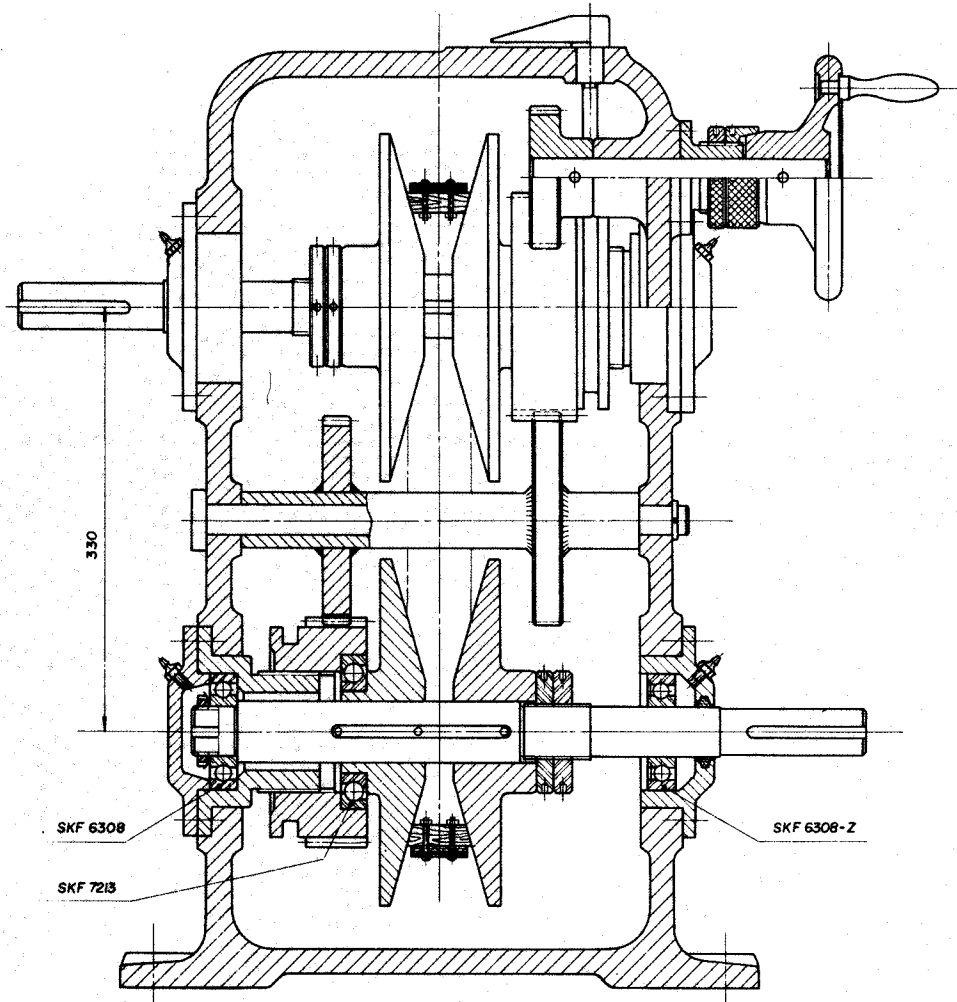
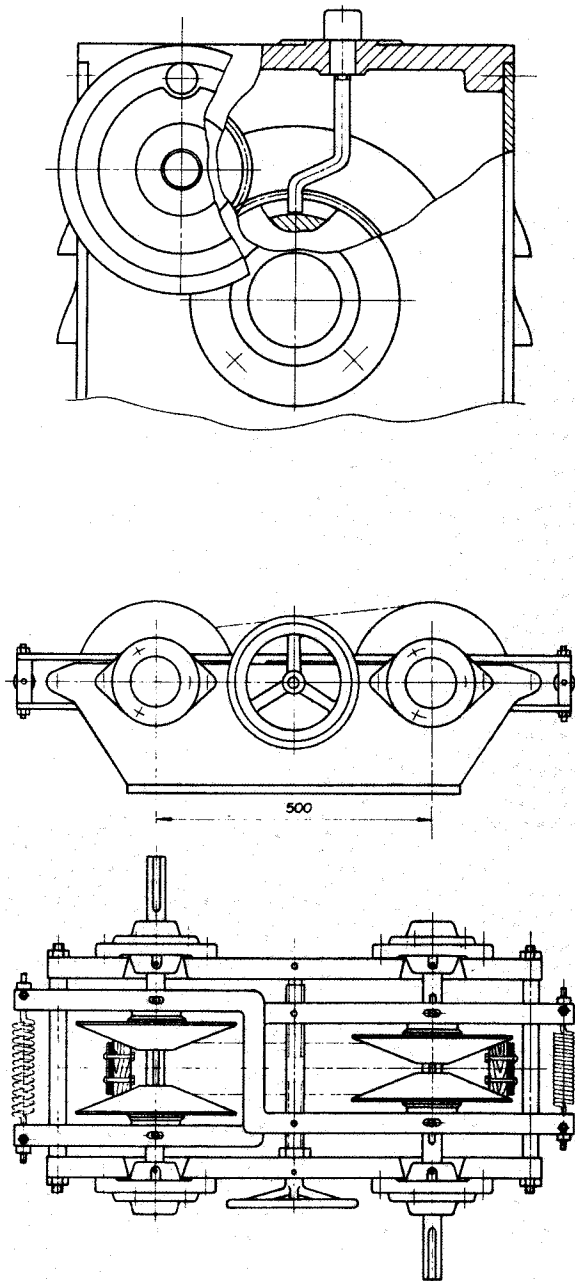

TIPOS DE VARIADORES DE VELOCIDADE

MANCAL DE ROLAMENTO

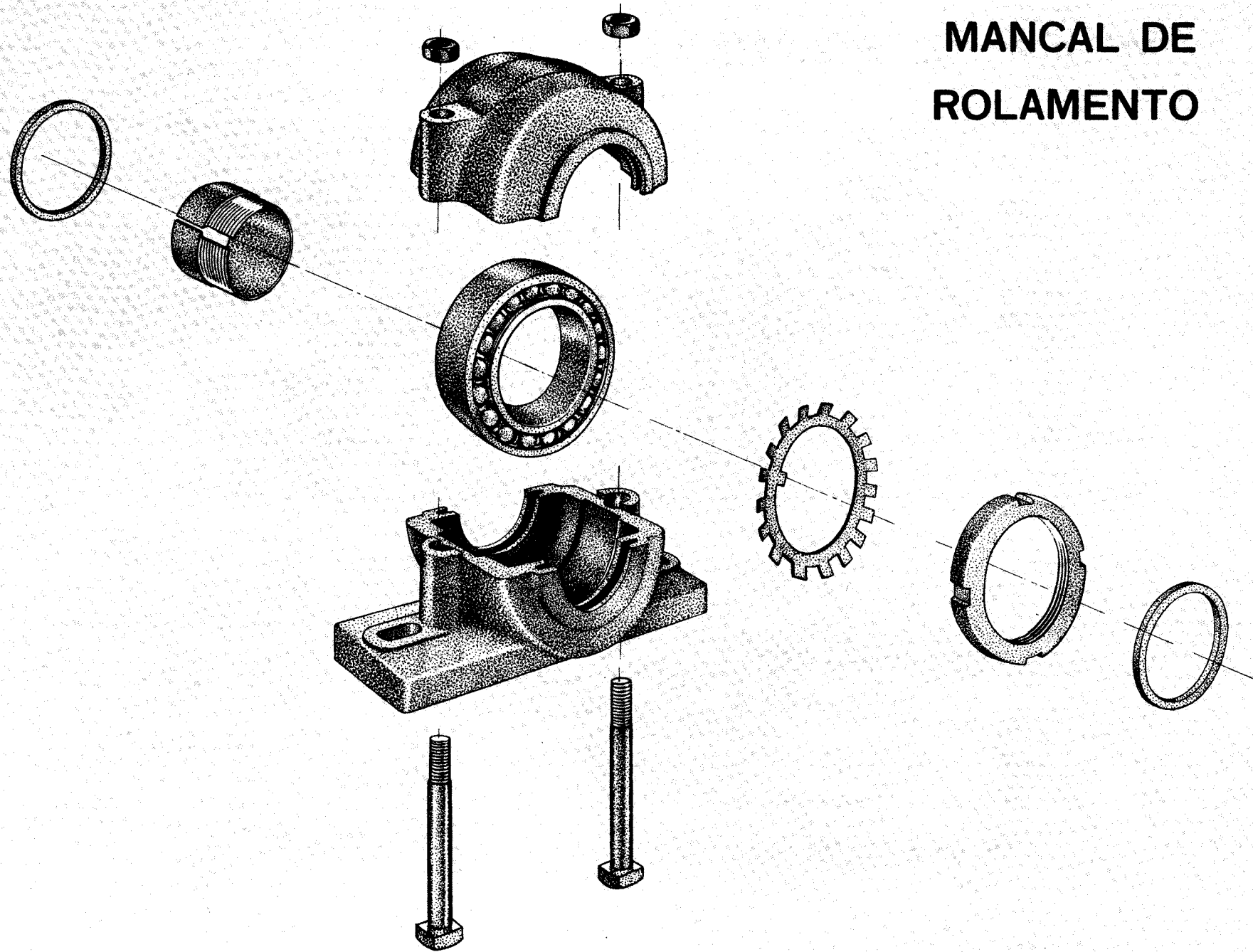

MANCAL DE ROLAMENTO

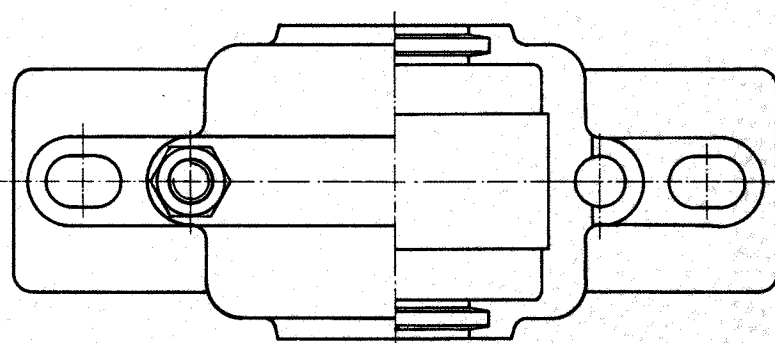
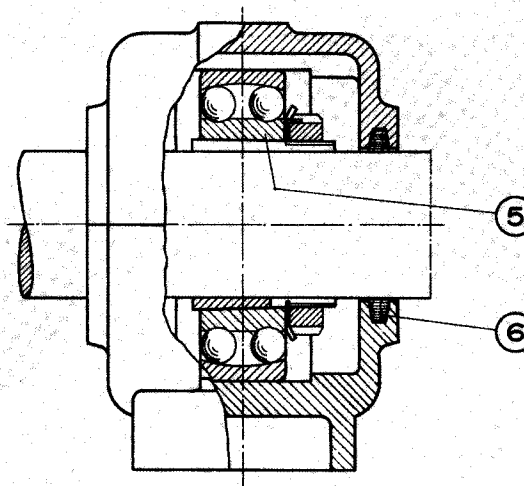
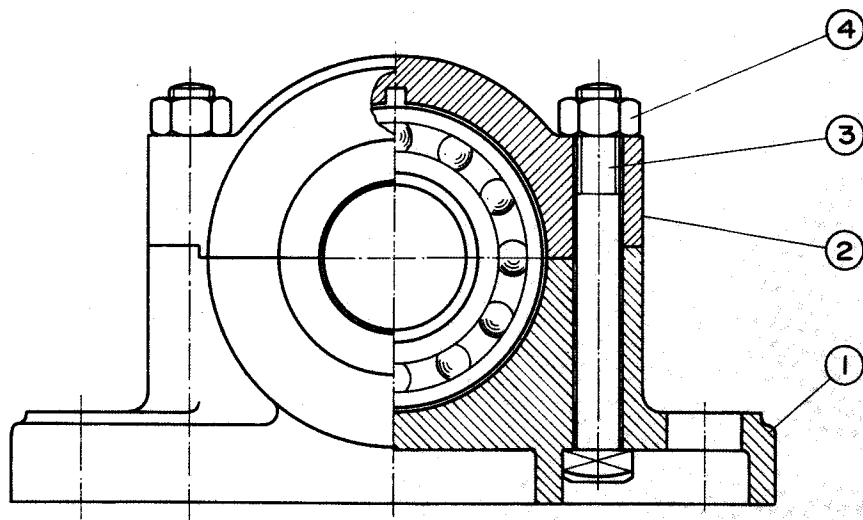

6	Guarnição	2	Feltro Ø53xØ40x5,5
5	Rolam. autocomp. com bucha de fix.	1	SKF 1209 K + H209
4	Porca sext.	2	M12
3	Paraf. cab. quad.	2	M12x100
2	Tampa	1	Ferro fundido
1	Corpo	1	Ferro fundido
Item	DENOMINAÇÕES	Quant.	MATERIAL E DIMENSÕES

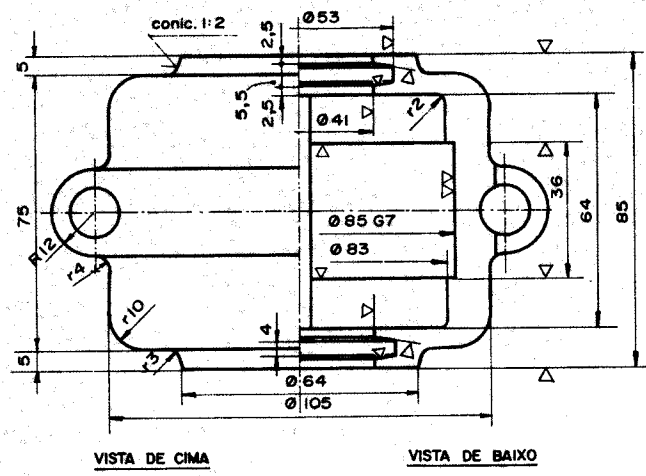
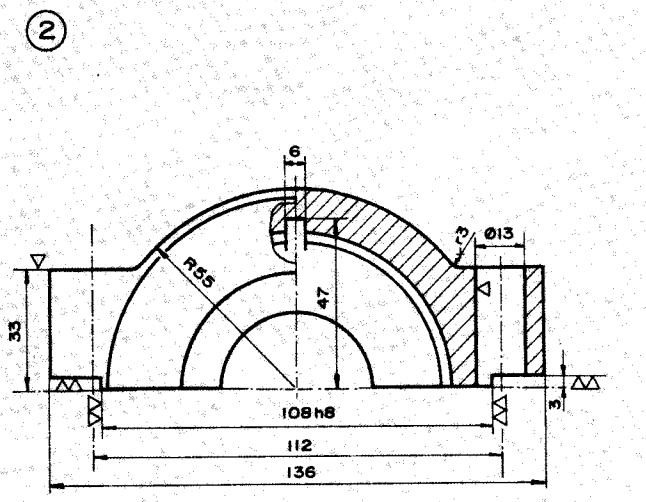

~(▽,▽)

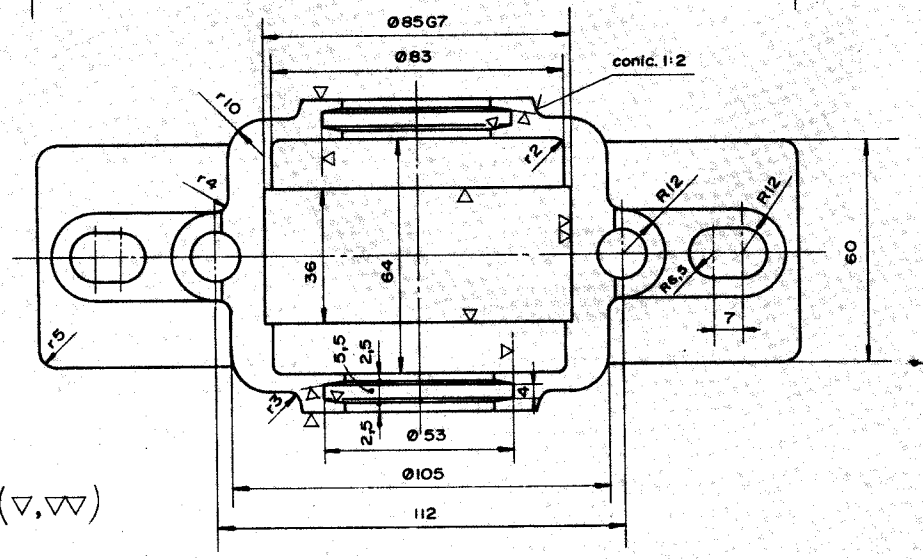
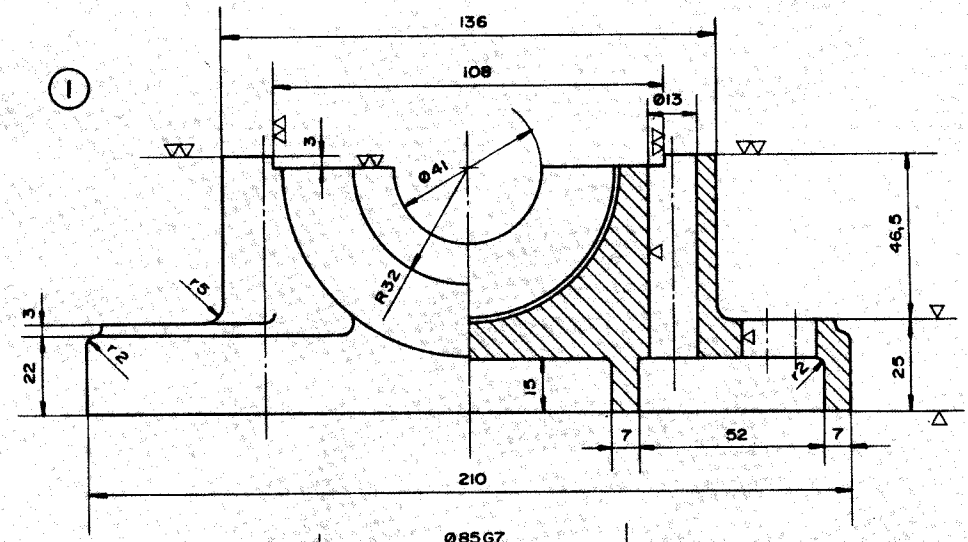

~(▽,▽)

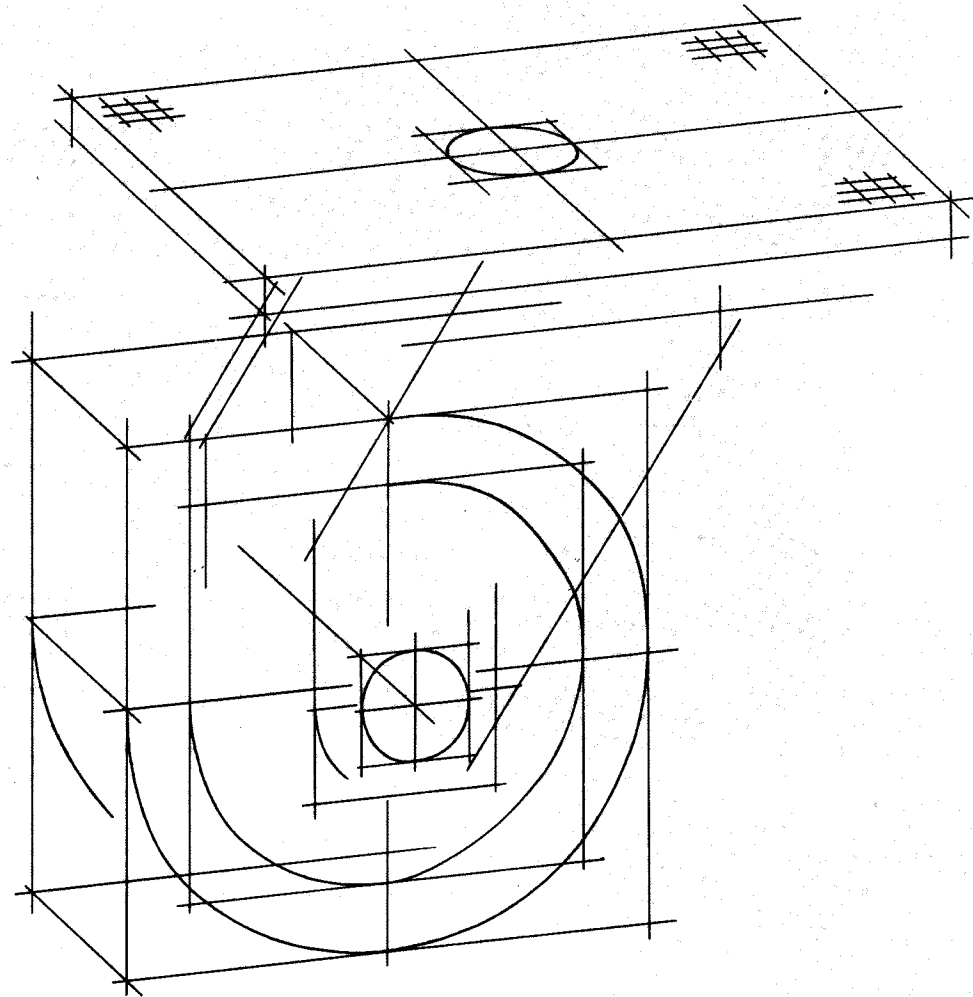
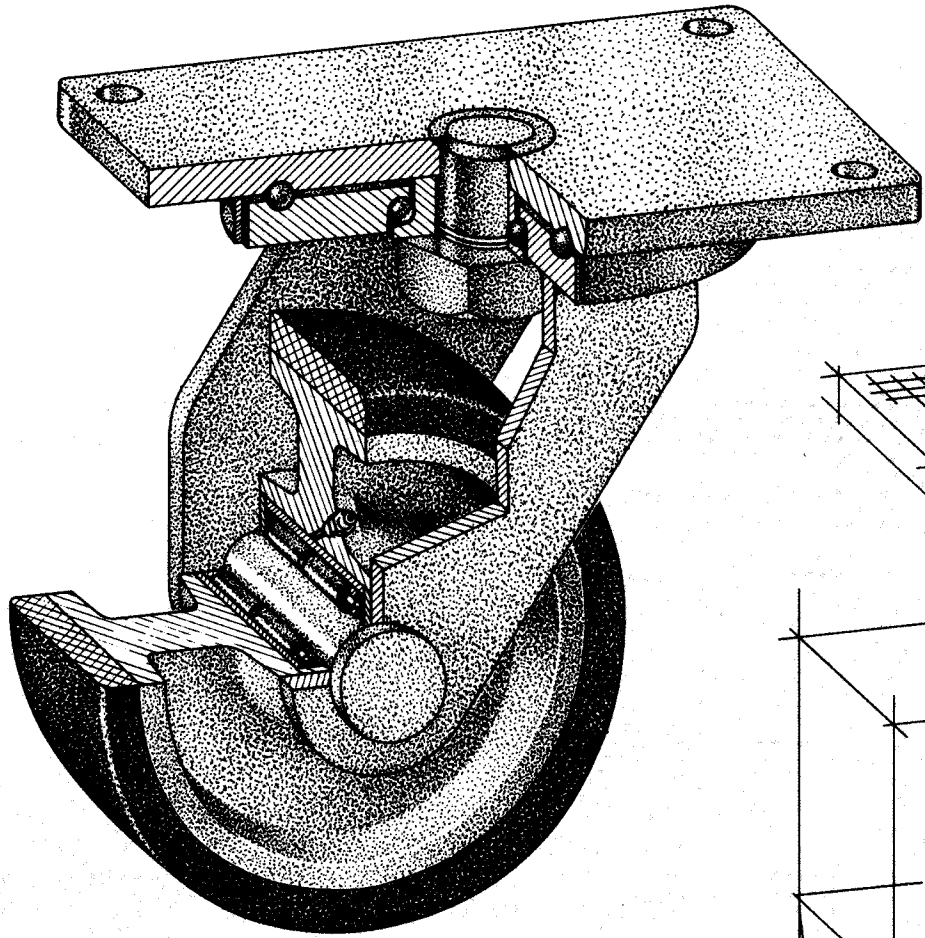

RODÍZIO GIRATÓRIO

RODÍZIO GIRATÓRIO

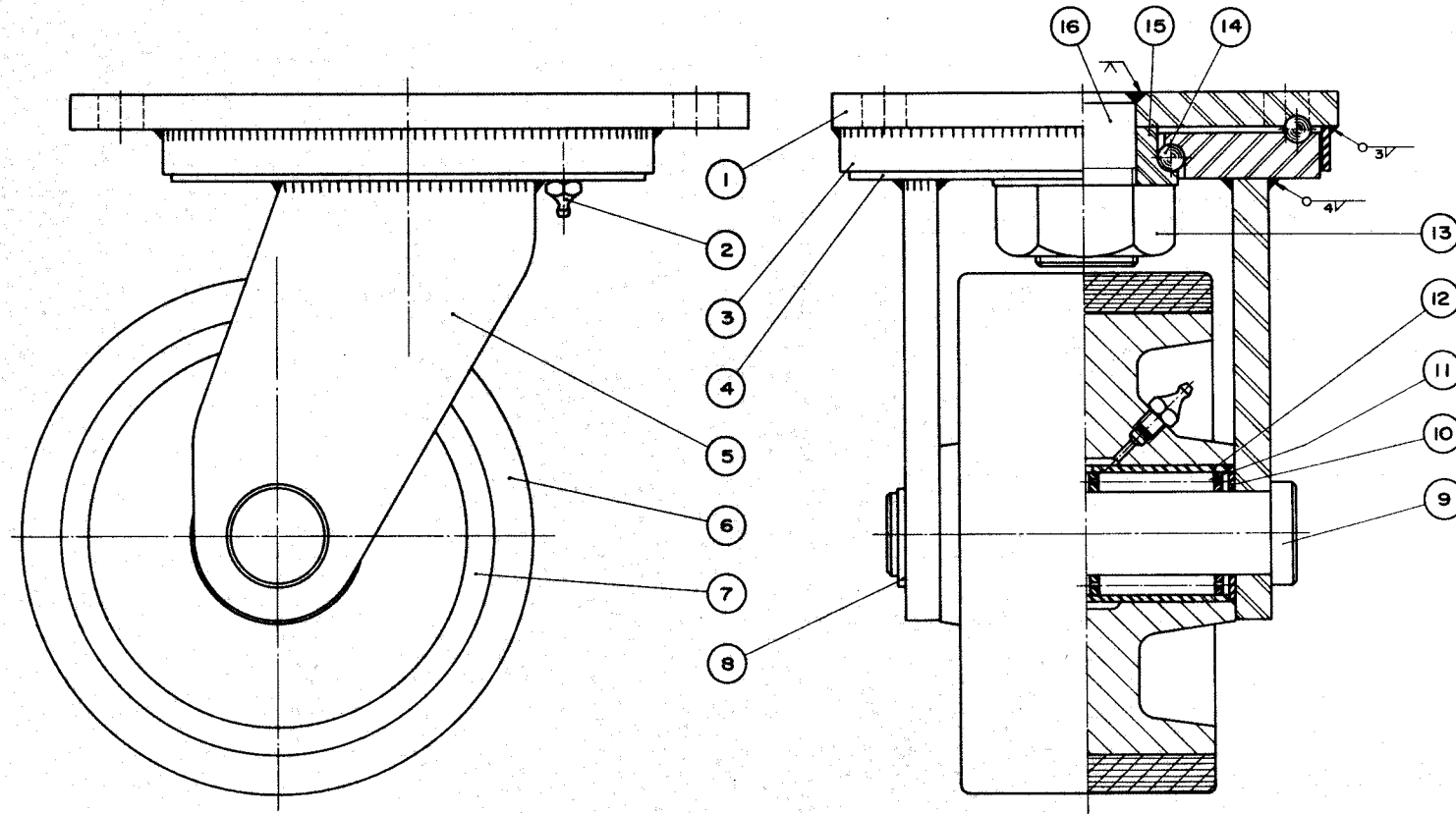

16	Paraf. sem cab.	1	Aço NB 1020	7	Roda	1	Ferro fundido
15	Encôsto	1	Aço NB 1030 cementado	6	Banda	1	Borracha Ø150xØ128x74
14	Esfemas	64	SKF Ø 5/16"	5	Braço	2	Aço NB 1020
13	Parca sextavada	1	Aço NB 1020 Ø 1 1/8" x20	4	Calço das esferas	1	Aço NB 1030 cementado
12	Bucha	1	Aço NB 1040	3	Chapa proteção	1	Aço NB 1010
11	Rolamentos Hyatt	2	Nº 94426	2	Engraxadeira lub	2	Ø1/4" - 28 SAE
10	Encôsto	2	Aço NB 1020 Ø40xØ24x2	1	Base	1	Aço NB 1020
9	Pino com cabeça	1	Aço NB 1030 cementado	Nº	DENOMINAÇÕES		MATERIAL E DIMENSÕES
8	Anel elástico	1	DAe 24				

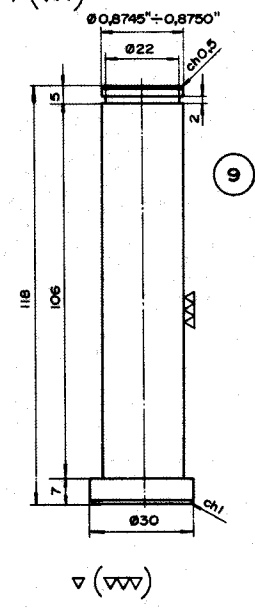
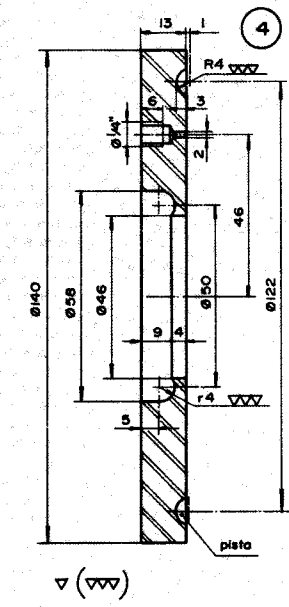
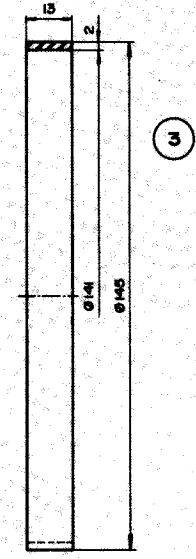
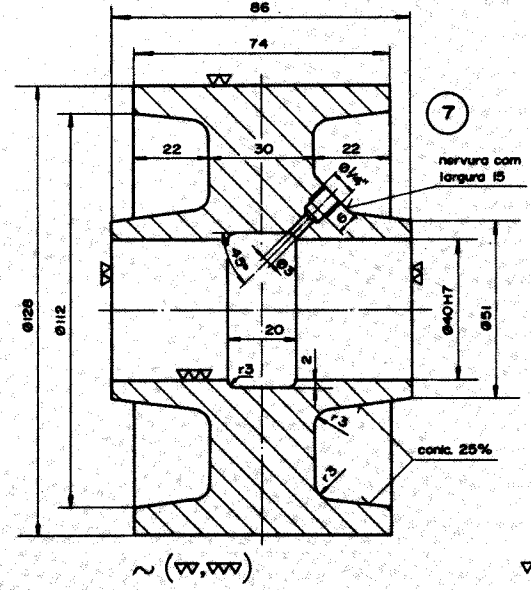
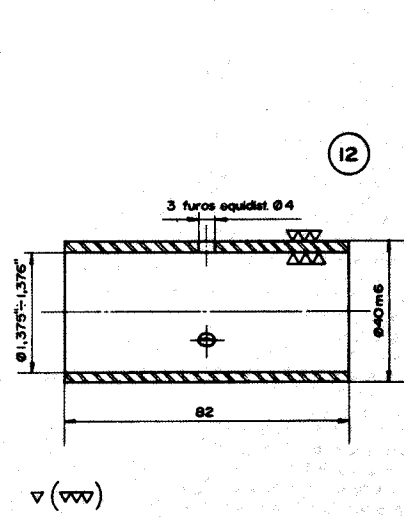
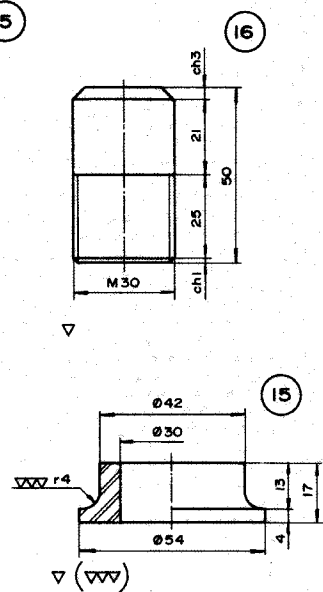
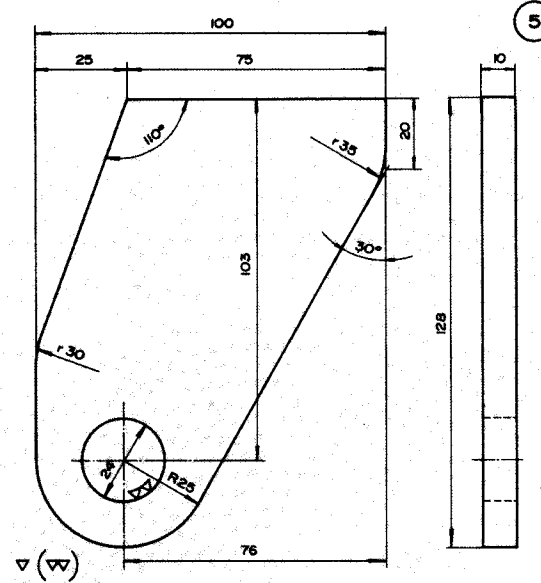
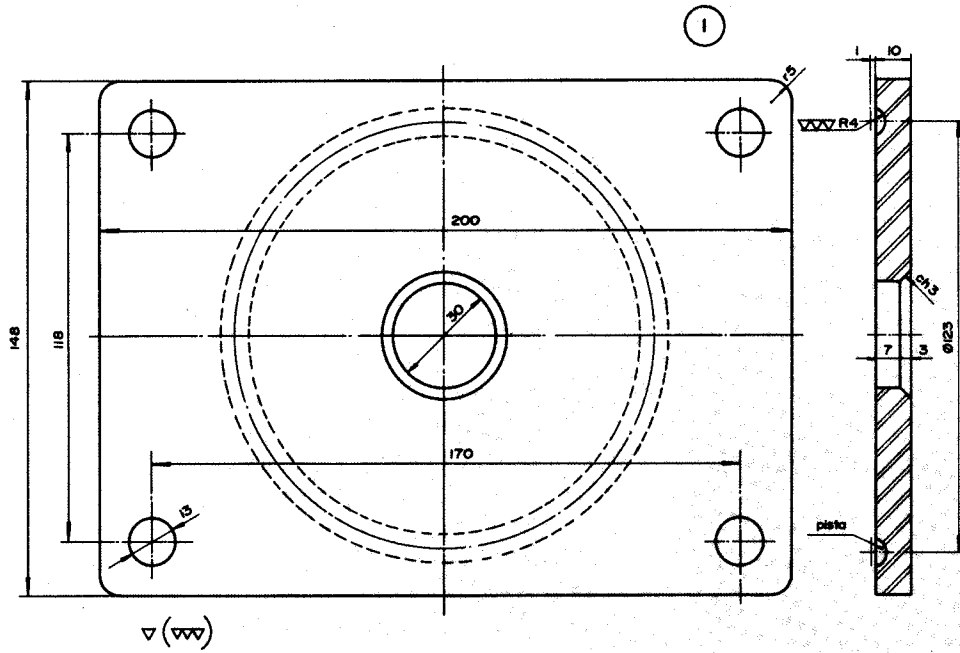

CONTRA-PONTA GIRATÓRIA

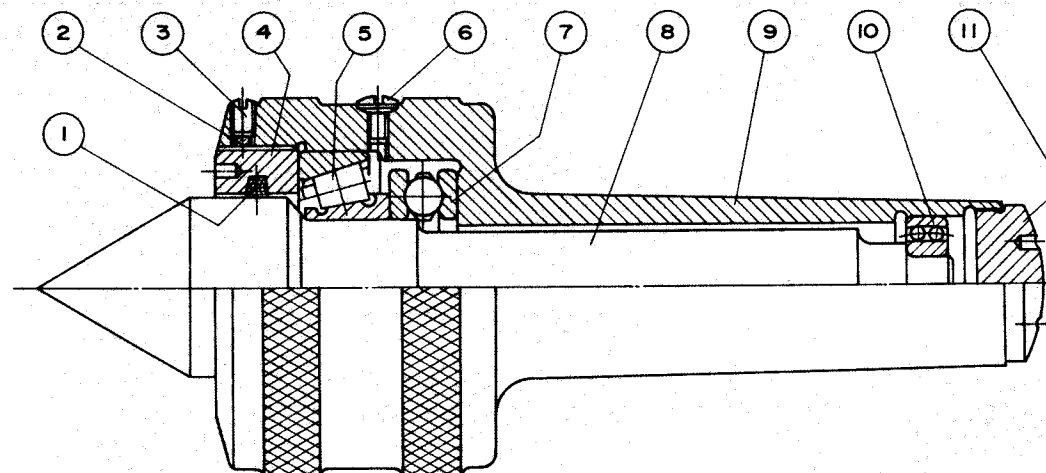
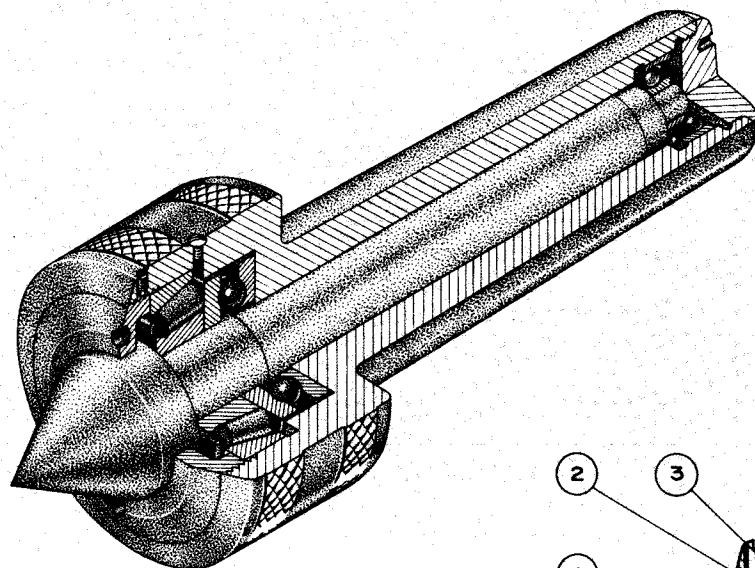

11	Tampa	1	Ferro fundido	5	Rol. rolo conico	1	SKF 32207
10	Rol. autocomp.	1	SKF 1202	4	Tampa	1	Ferro fundido
9	Corpo	1	Ferro fundido	3	Paraf. de fix.	1	Ø1/4"x9
8	Ponta (cementada)	1	Aço NB 1040	2	Trava	1	Latão tref. Ø4
7	Rol. de escora	1	SKF 51207	1	Retentor	1	Feltro Ø48
6	Paraf. cab. oval	1	Ø1/4" x 10	Item	DENOMINAÇÕES	QUANT.	MATERIAL E DIMENSÕES

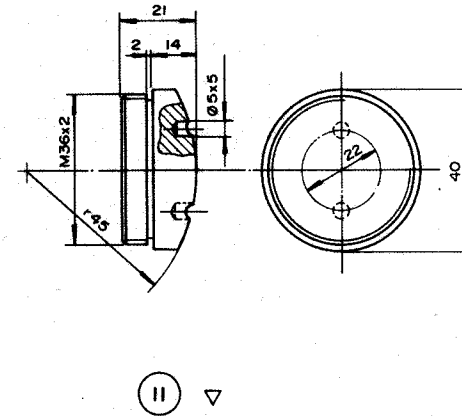
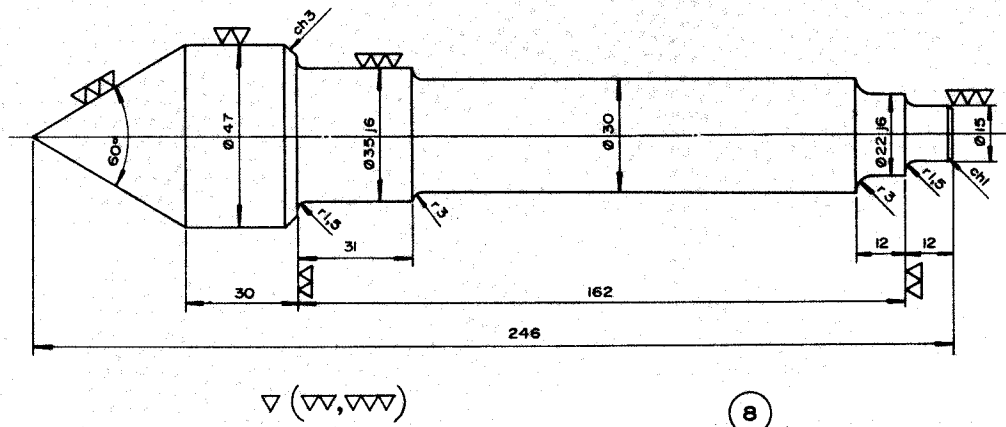
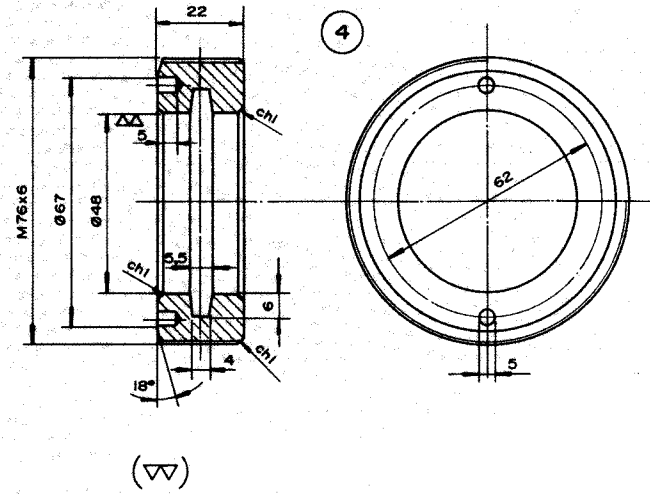
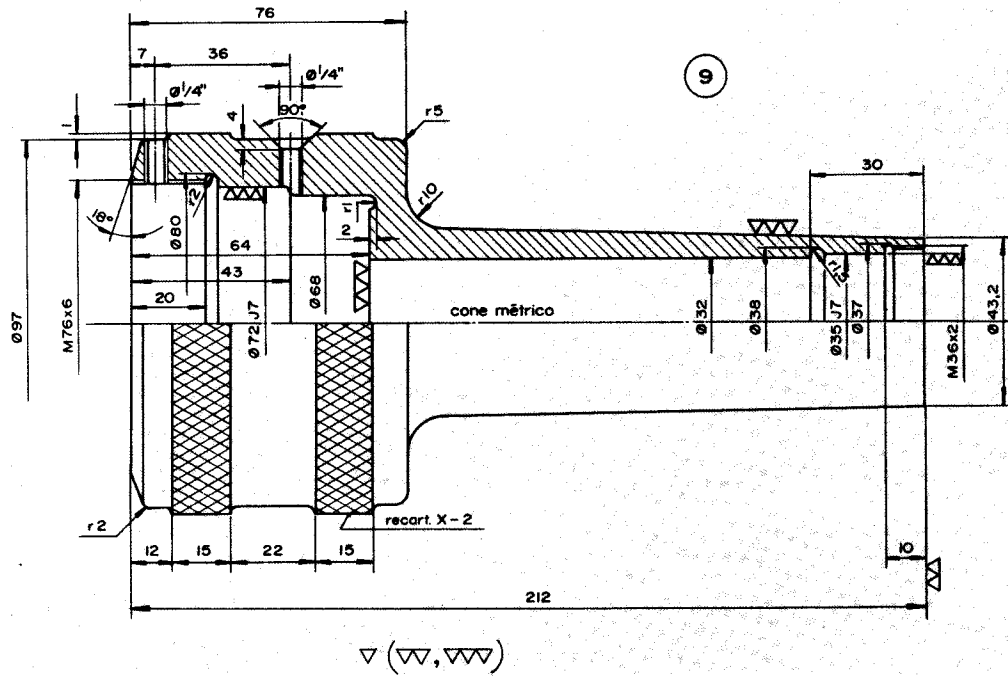

GANCHO

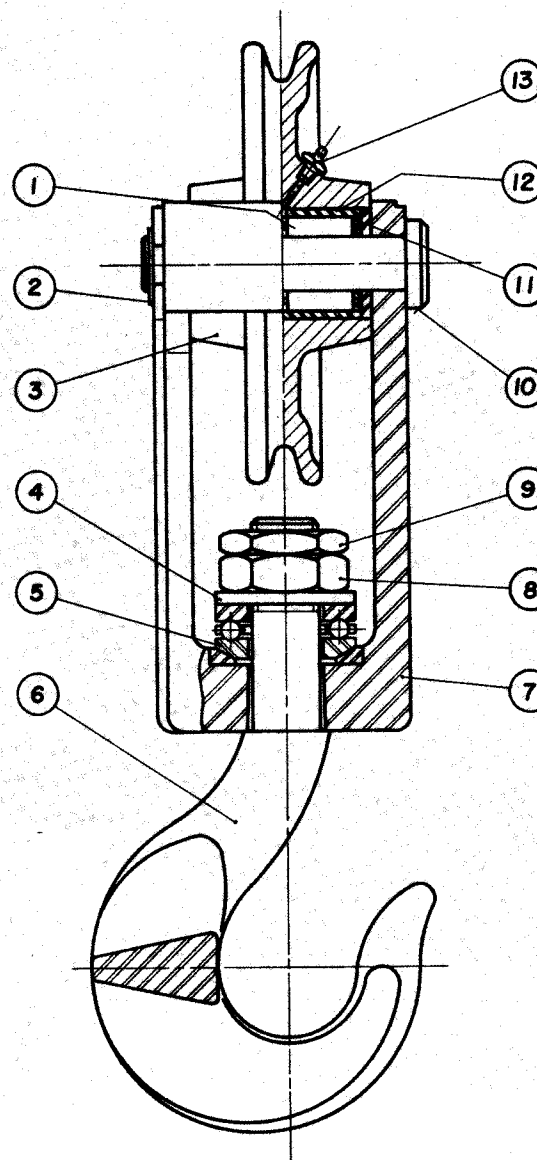
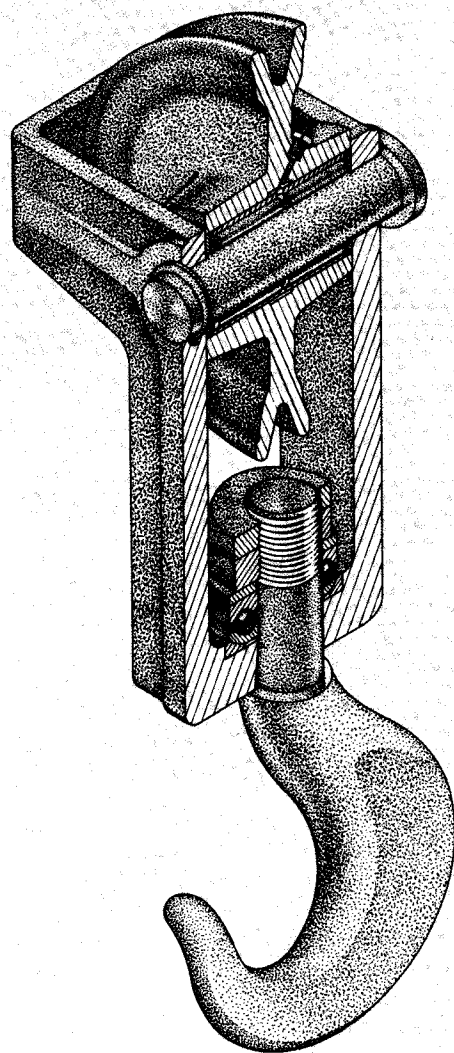

13	Engraxadeira lub	1	Ø1/8" Gás
12	Bucha	1	Aço NB 1040
11	Tampa	2	Aço NB 1020 Ø65xØ38x2
10	Pino com cab.	1	Aço NB 1050
9	Contra-porca	1	M35
8	Porca sextavada	1	M35
7	Suporte	1	Aço NB 6020 AF
6	Gancho	1	Aço forjado NB 1040
5	Rol. de escora	1	SKF 53308 U
4	Arruela	1	Ø1/2"
3	Polia	1	Ferro fundido esferoidal
2	Anel elástico	1	DAe 38
1	Bucha de agulhas	2	Hyatt N° 95932
N°	DENOMINAÇÕES	Quant.	MATERIAL E DIMENSÕES

GANCHO COM TRAVA

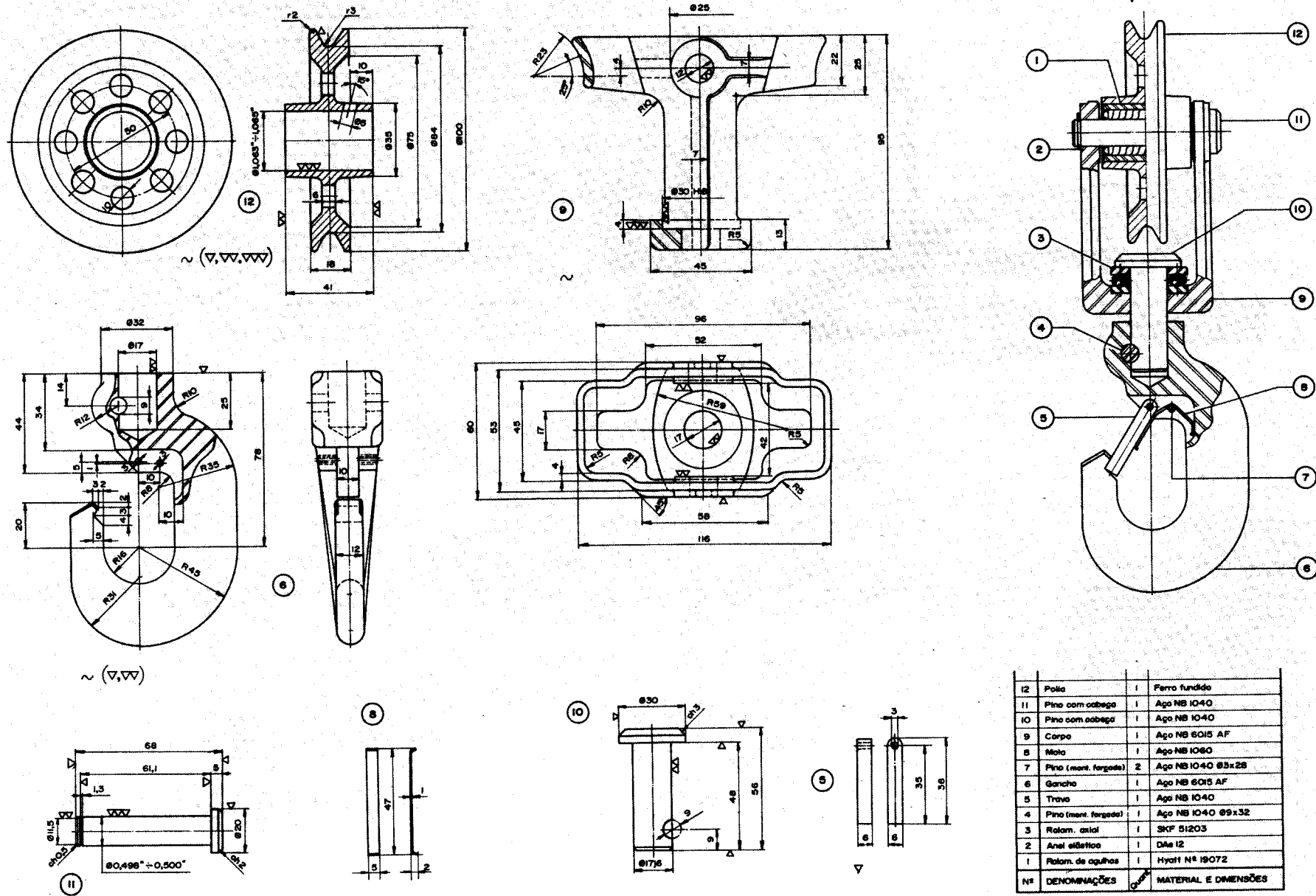

MÁQUINA DE REBITAR

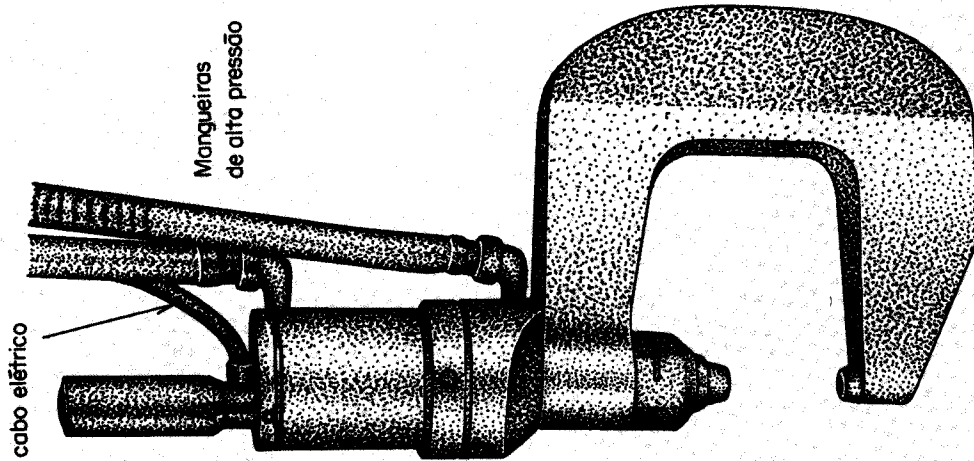

20	Arco	1	Aço forjado NB 1050
19	Punções	2	Aço VW-9 Villars
18	Paraf. "ALLEN"	1	Ø 3/16" x 18
17	Porca especial	1	Aço NB 1020
16	Paraf. cab. cilínd.	1	Ø 3/16" x 8
15	Pino	1	Aço NB 1010
14	Retentor	1	Ø 1 9/16" x Ø 1/8" x 3/8"
13	Guarnição	1	Couro Ø 3/16" x Ø 3/16" x 1/16"
12	Paraf. "ALLEN"	1	Ø 3/16" x 12
11	Guarnição	1	Couro Ø 2 5/8" x Ø 2 3/8" x 1/8"
10	Corpo	1	Aço NB 1030
9	Porca especial	1	Aço NB 1020
8	Eixo	1	Aço NB 1020
7	Anel elástico	1	DAI 35
6	Camisa	1	Aço Ni Cr NB 3120
5	Anel	3	Ferro fundido nodular
4	Pistão	1	Aço NB 1020
3	Bico	2	Aço NB 1020
2	Interruptor	1	Micro Sivantia
1	Paraf. "ALLEN"	1	Ø 3/8" x 18
Nº	DENOMINAÇÕES		MATERIAL E DIMENSÕES

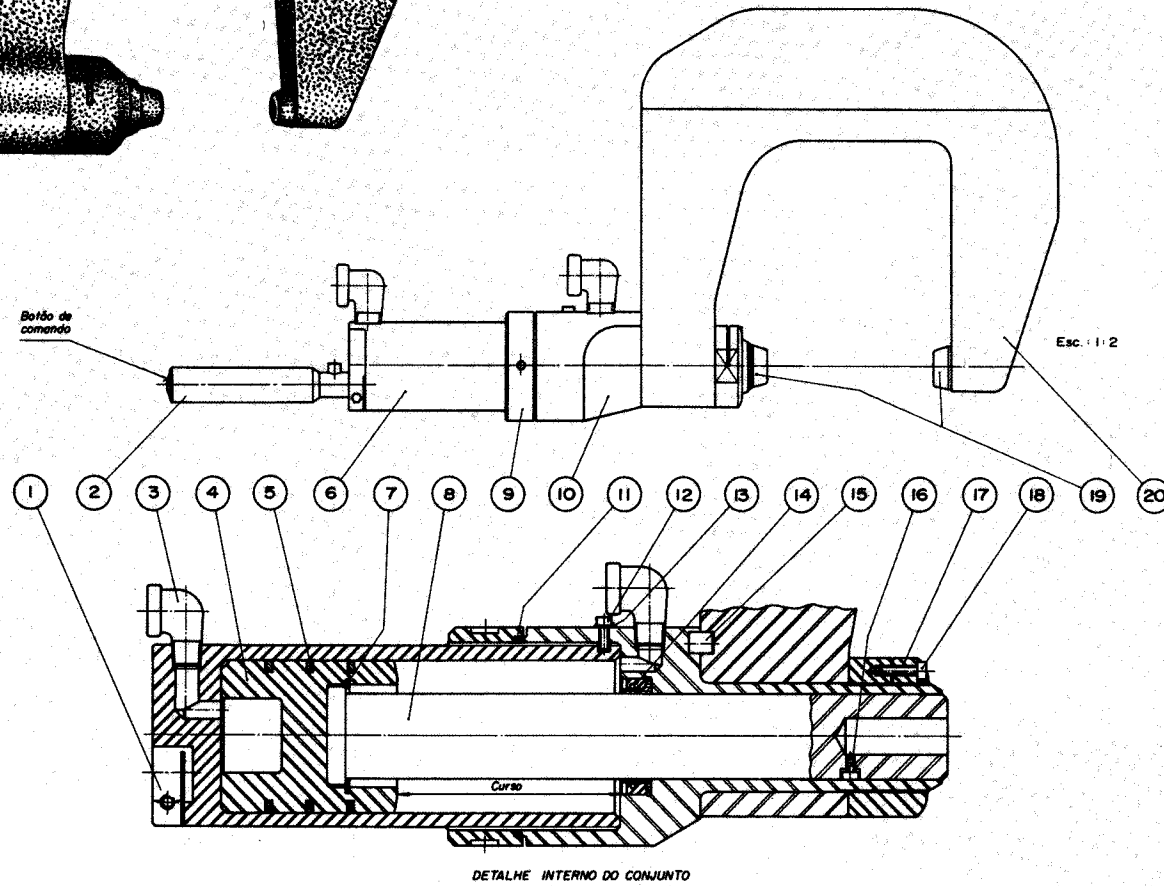

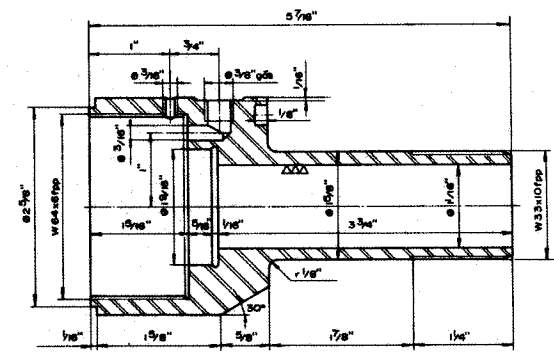
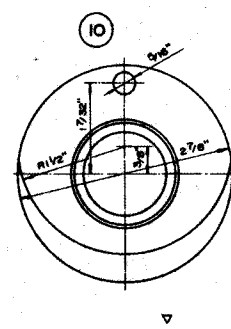
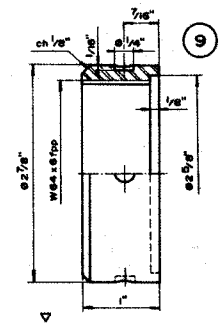
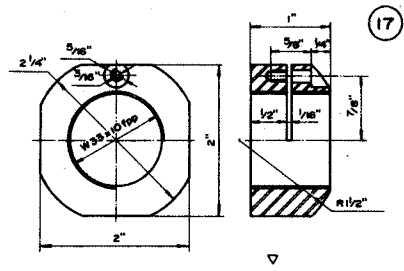
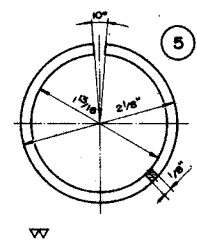
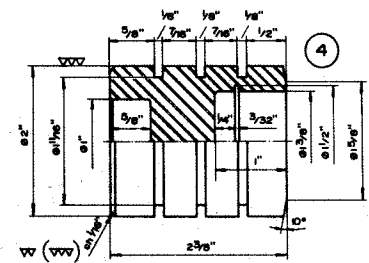
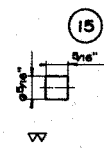
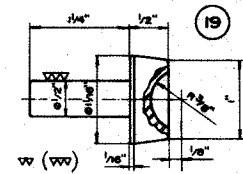
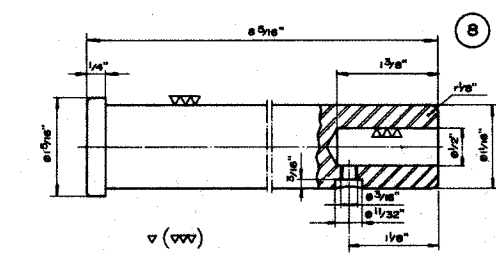
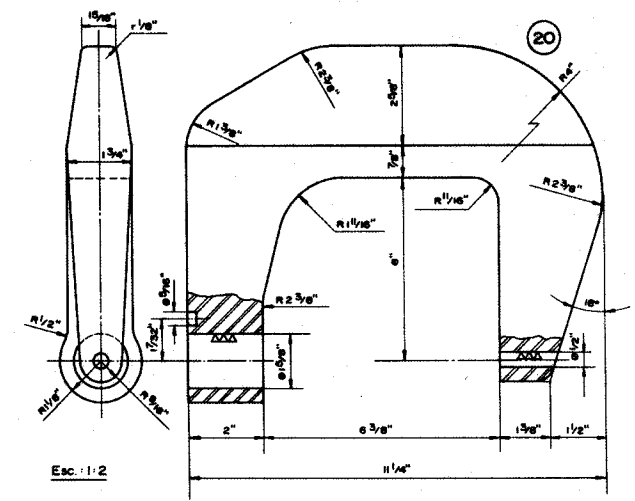
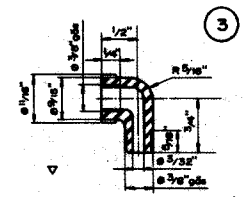
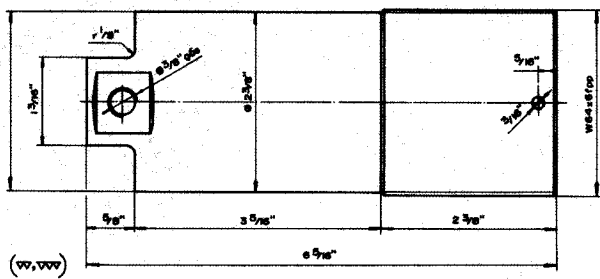
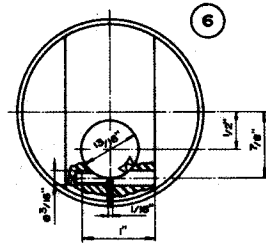
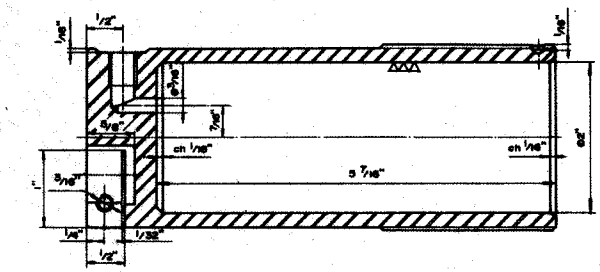

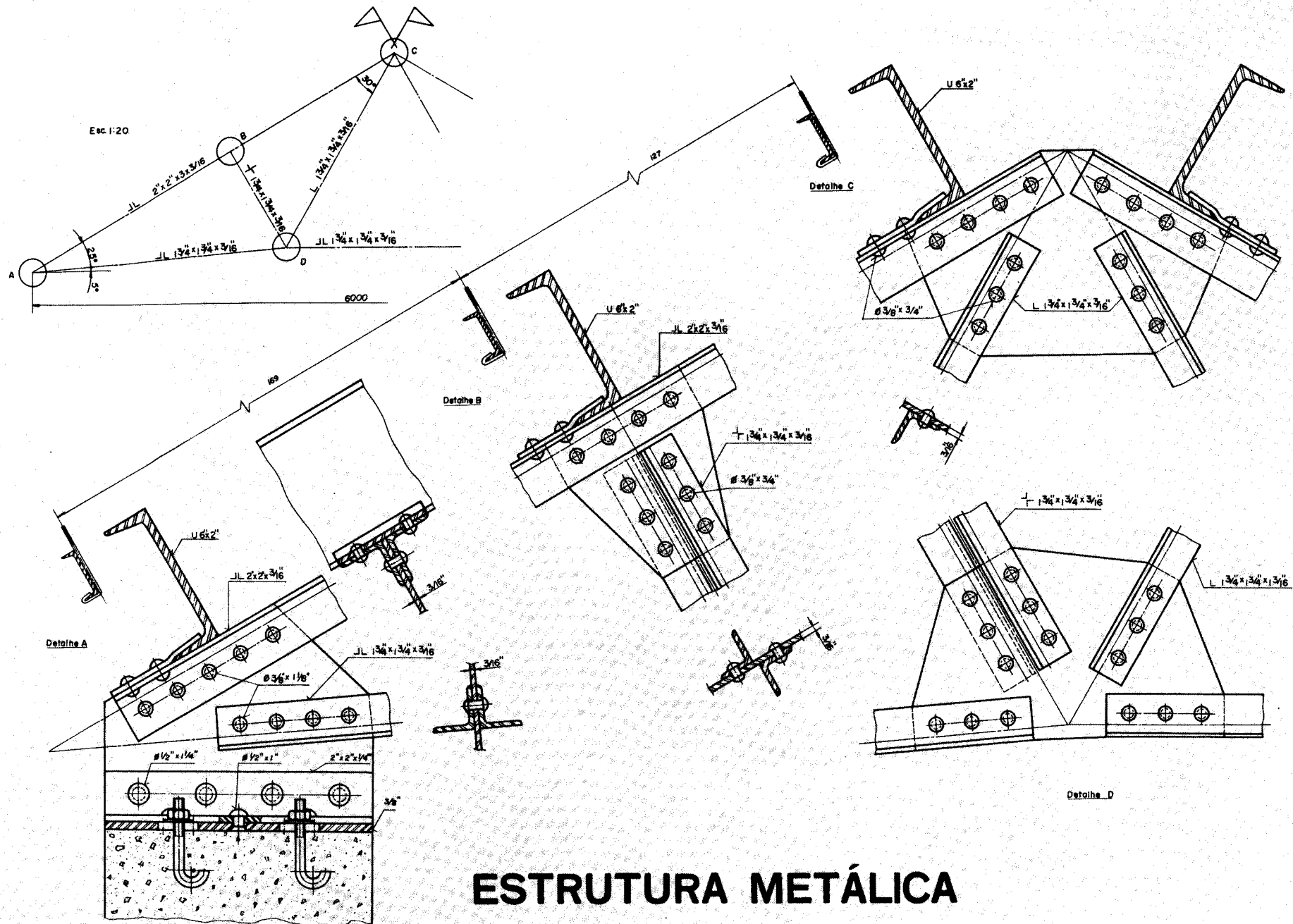

ESTRUTURA METÁLICA

JANELAS DE CORRER - ESQUADRIAS DE FERRO

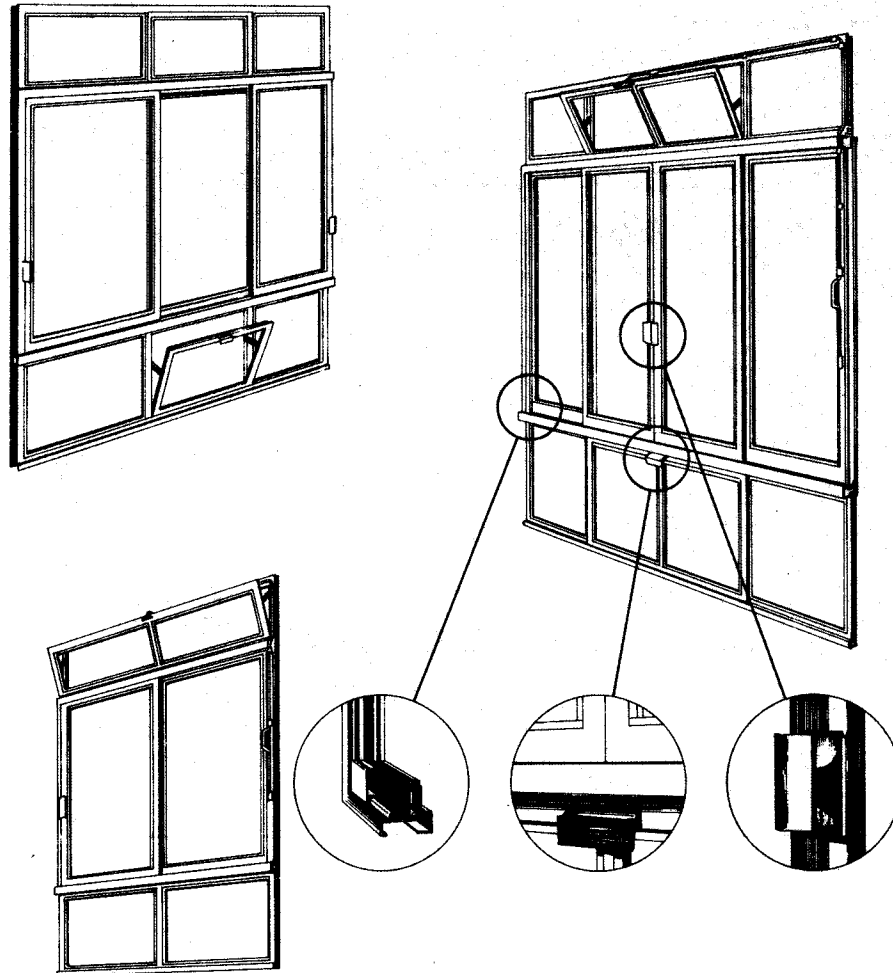

BANDEIRAS

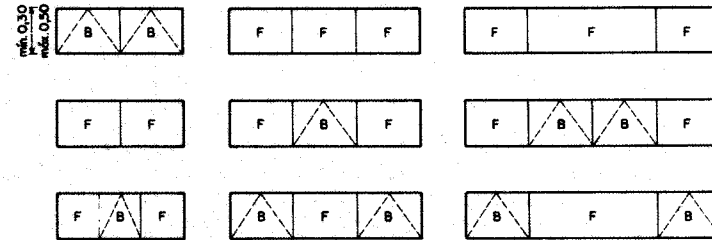

JANELAS

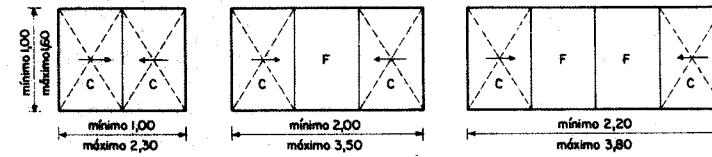

PEITORIS

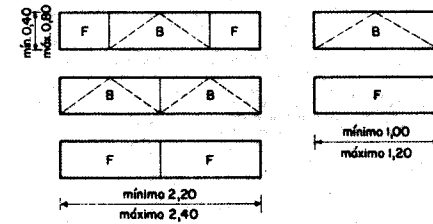

CONVENÇÃO

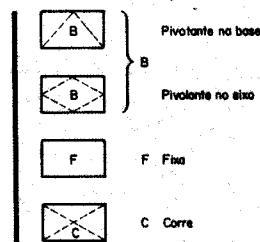

COMBINAÇÕES DE ELEMENTOS DIFERENTES

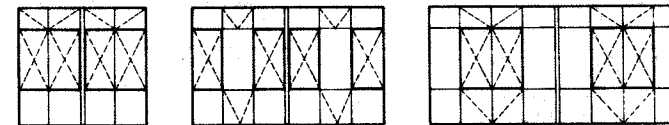

JANELA DE CORRER - DETALHES

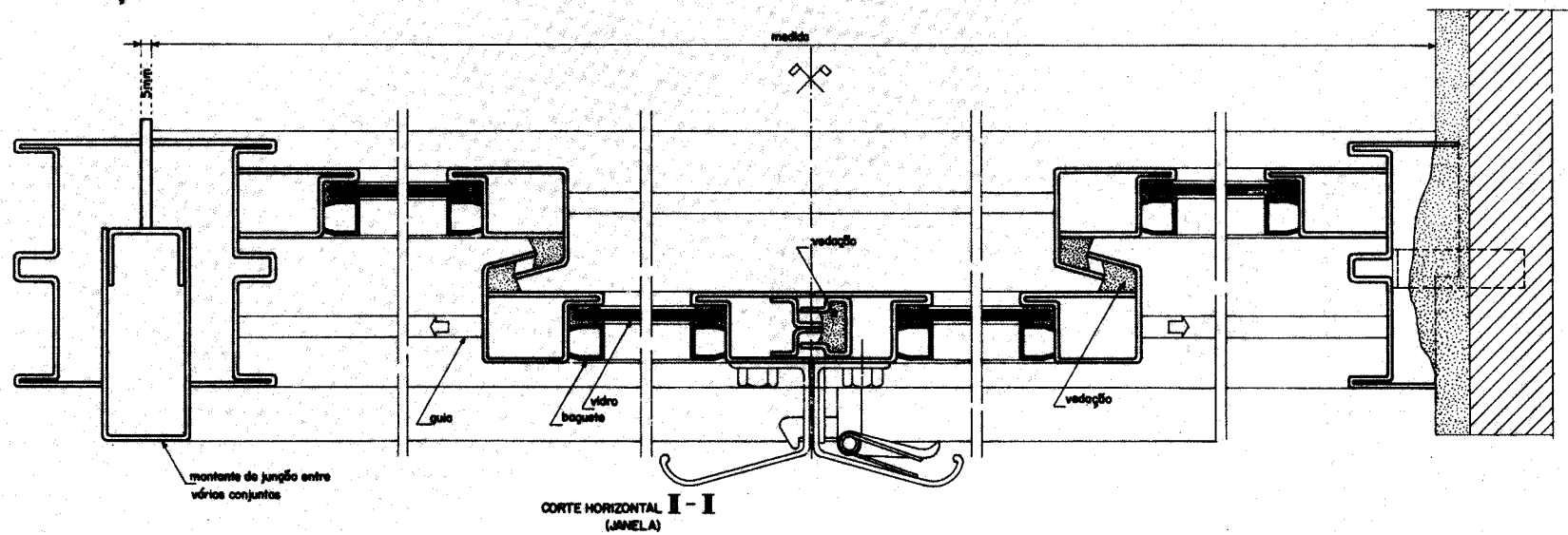
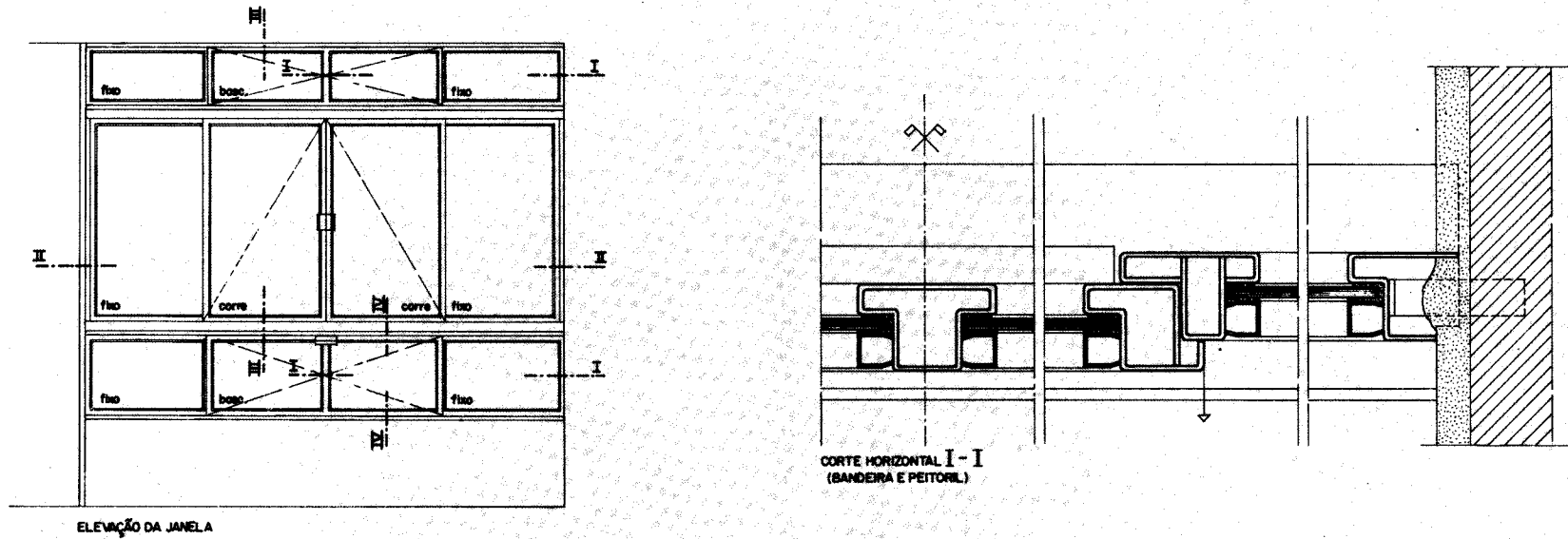

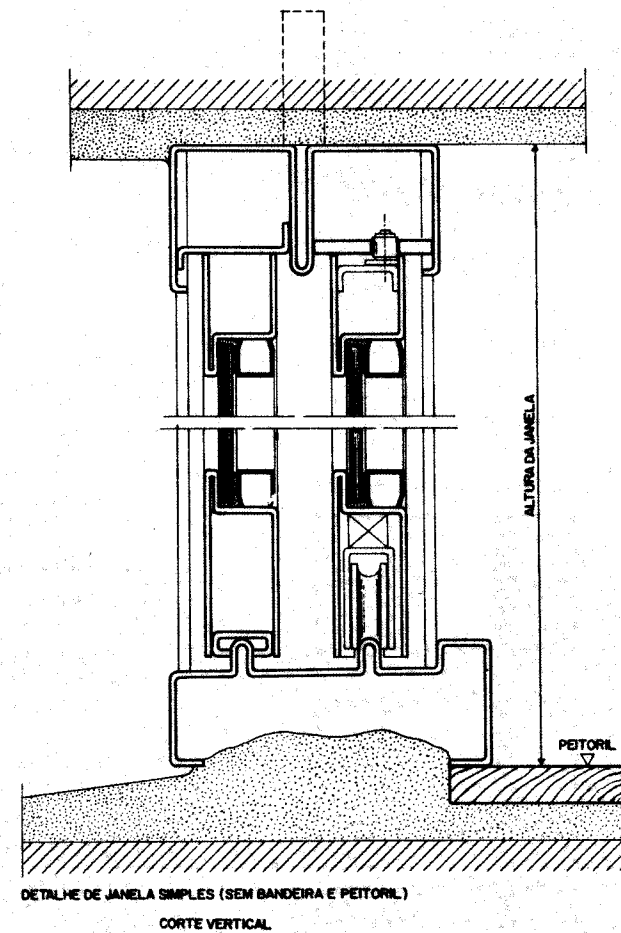
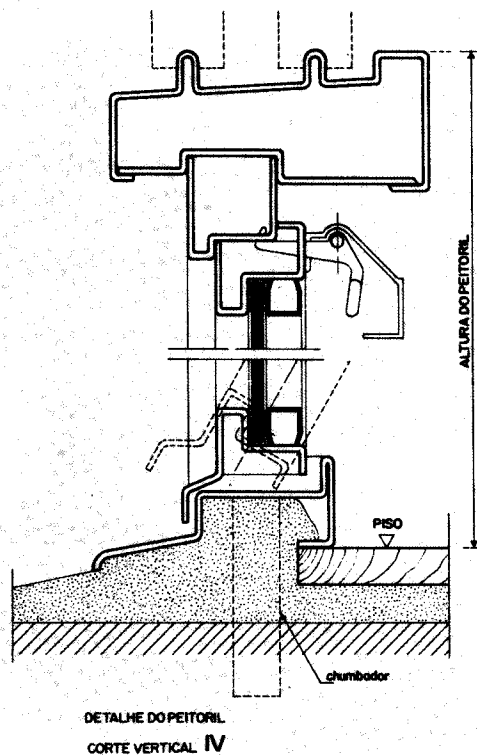
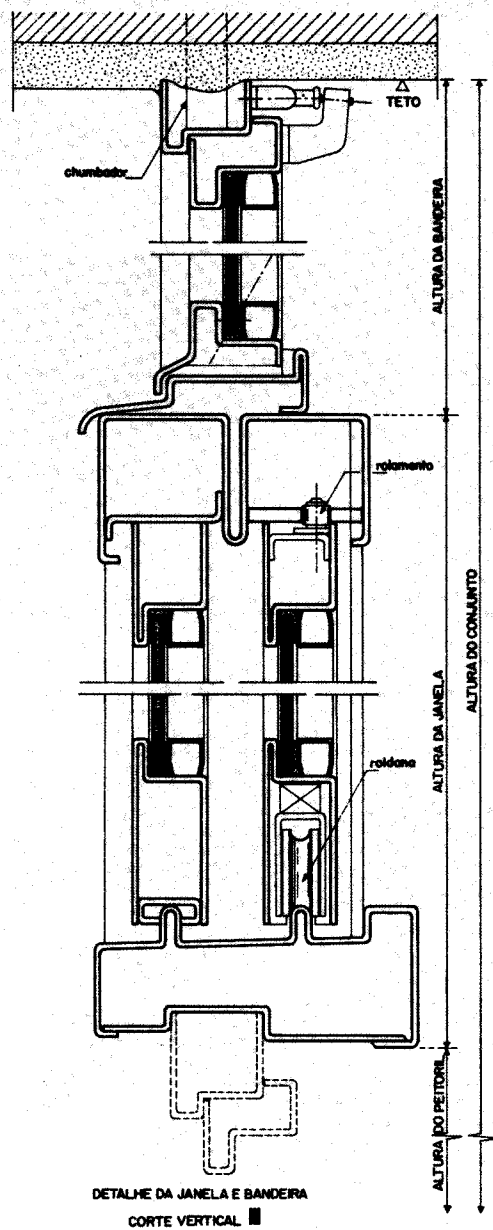

JANELA GUILHOTINA

PERSPECTIVA

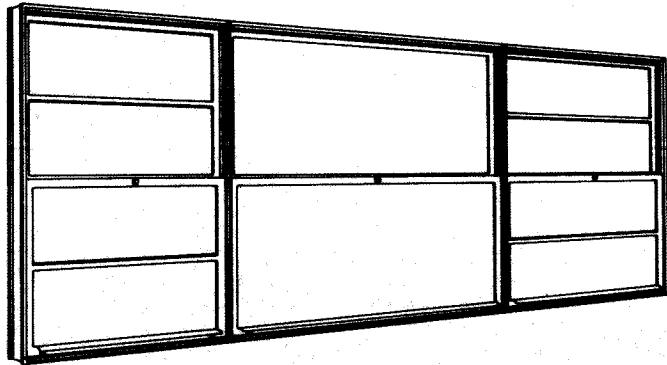

TIPOS E MEDIDAS STANDARD

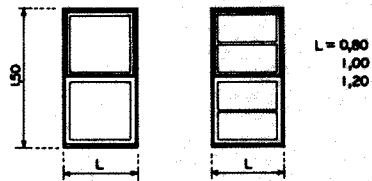

SUGESTÕES P/ FORMAÇÃO DE CONJUNTOS

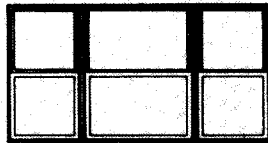

LEGENDA

- ① Massa de vedação
- ② Chumbador
- ③ Quadro ou batente
- ④ Guia de matéria plástica
- ⑤ Vidro
- ⑥ Montante de junção
- ⑦ Travessa

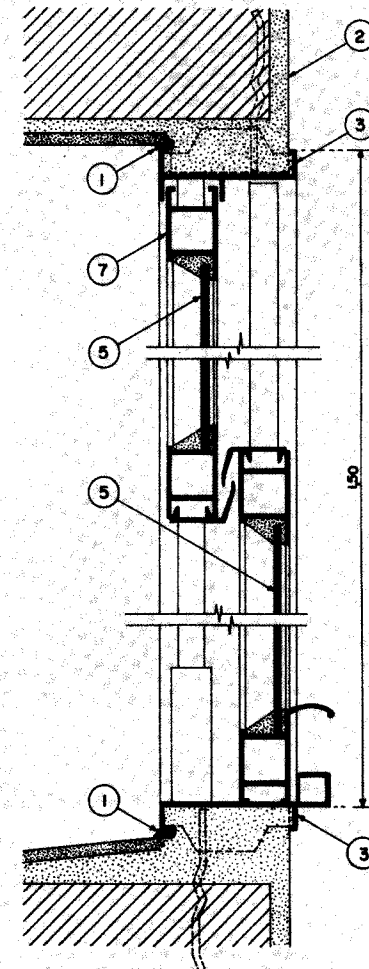
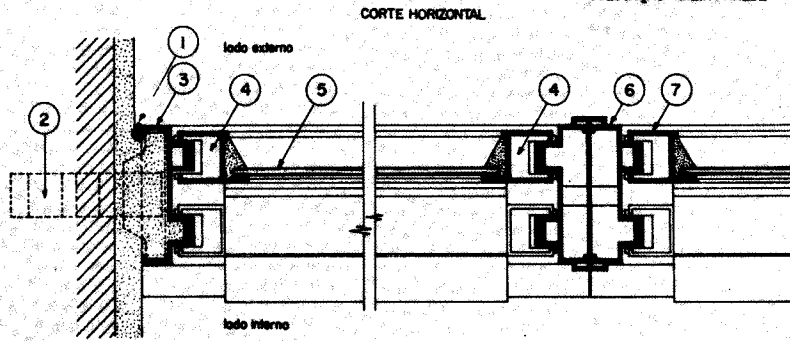
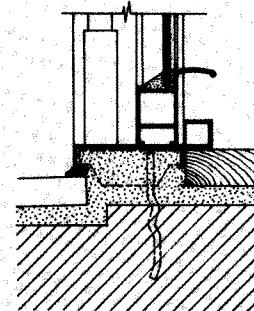
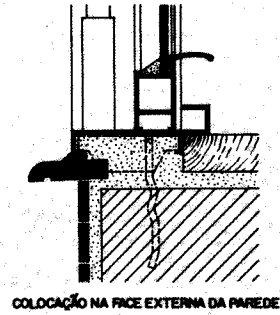

COLOCAÇÃO NA FACE INTERNA DA PAREDE

JANELA BASCULANTE

PERSPECTIVA

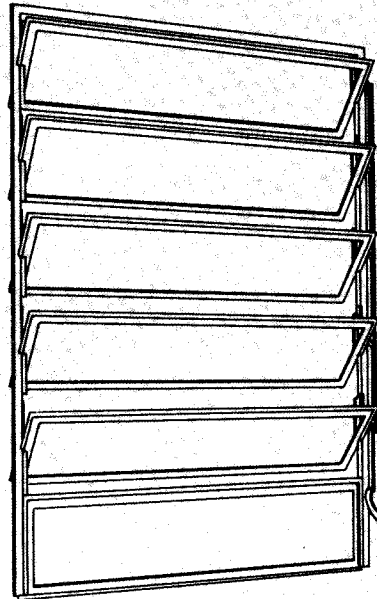

LEGENDA

- | | |
|-----------------------------|----------------------|
| ① Chumbador | ④ Quadro |
| ② Recobrimento lado externo | ⑤ Montante de função |
| ③ Recobrimento lado interno | ⑥ Vidro |

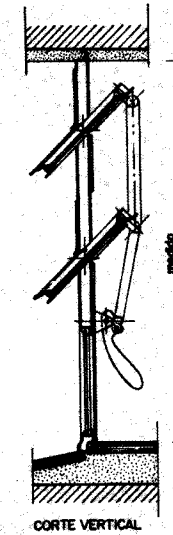
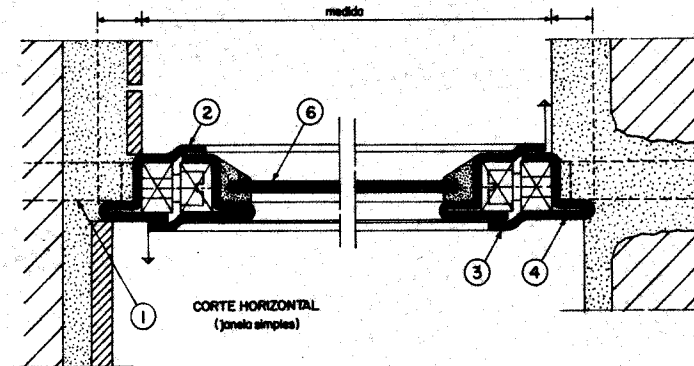

TIPOS DE CABILHOS

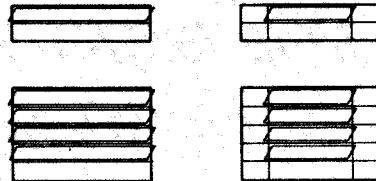

CAIXILHO C/ PORTA CONJUGADA

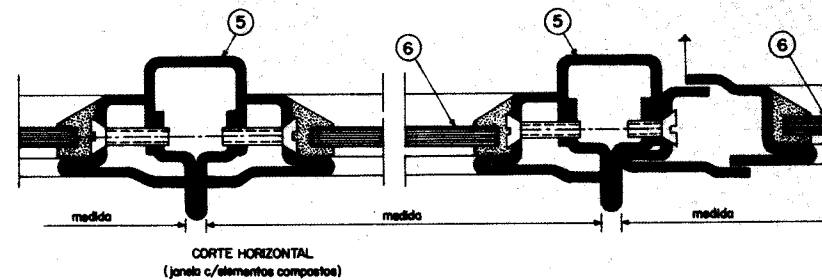
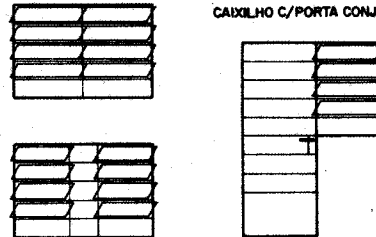

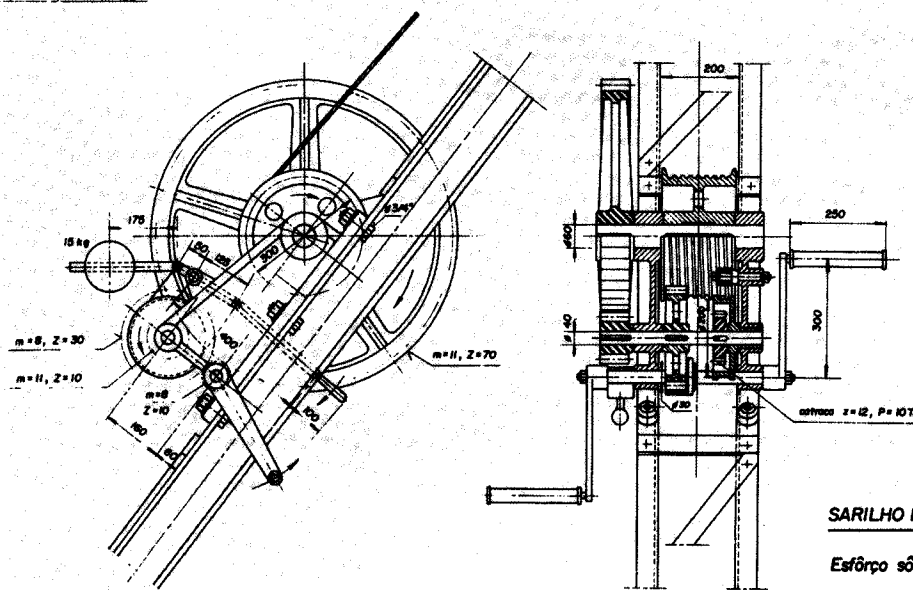
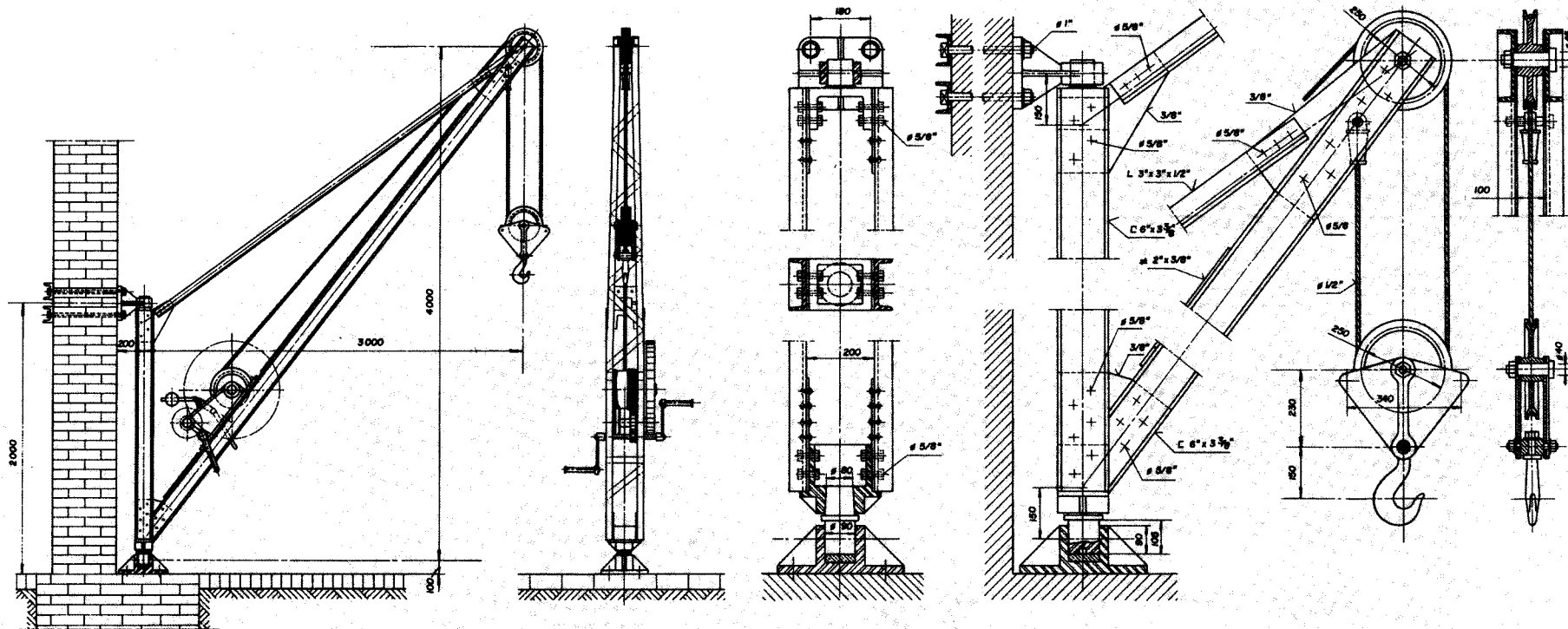

GUINDASTE GIRATÓRIO DE PAREDE

CARGA : 2 ton

LANCE : 3m

SARILHO MANUAL DE 1000 kg

Esforço sobre cada manivela : 15 kg

SARILHO PARA 250 KG

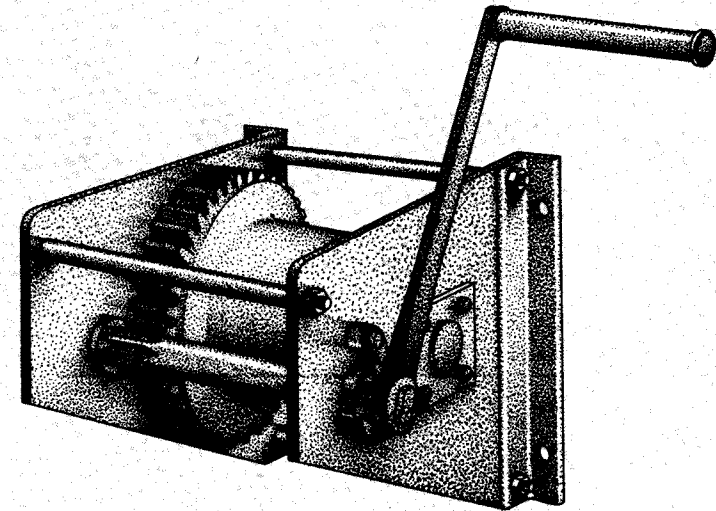
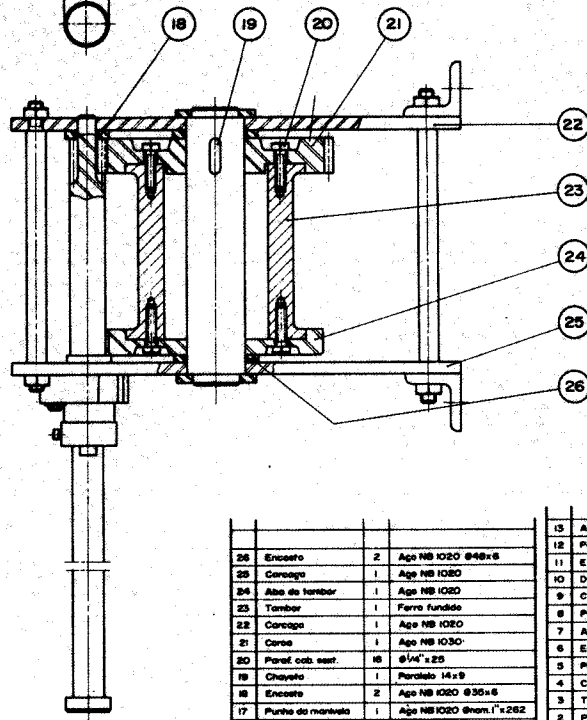
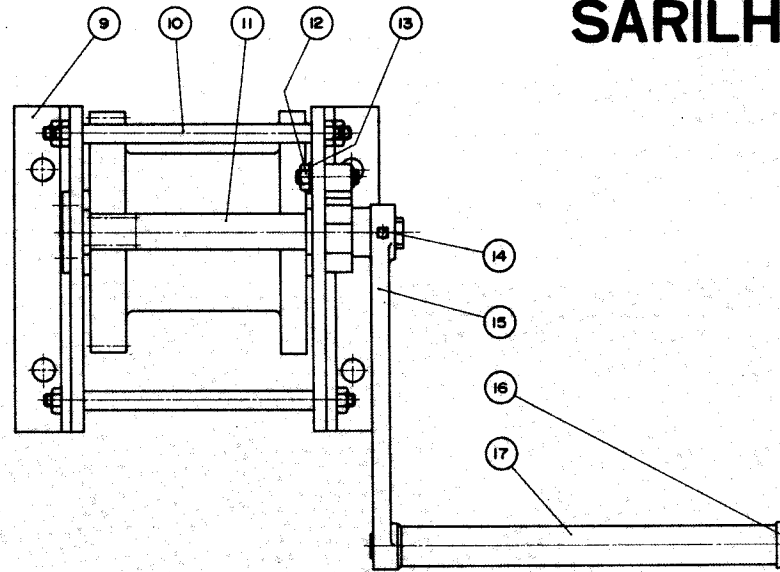
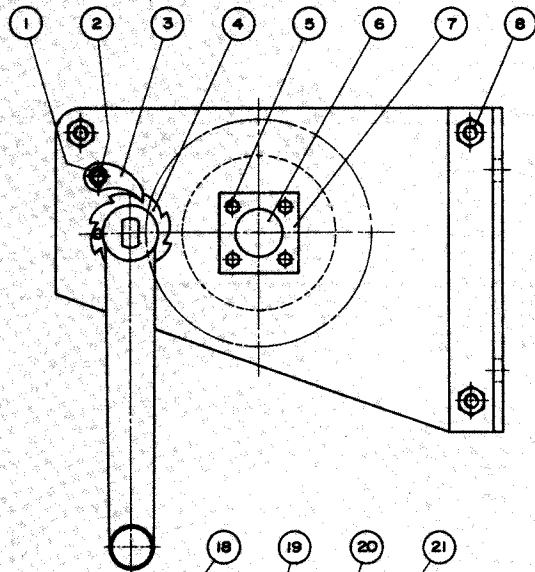

28	Encosto	2	Aço NB 1020 648x8	15	Arruela de pressão	1	Ø7
29	Coroaço	1	Aço NB 1020	16	Porca sextavada	1	Ø5/16" x 8
30	Alta do tambor	1	Aço NB 1020	11	Eixo do pinhão	1	Aço NB 1040
23	Tambor	1	Ferro fundido	10	Distanciad. v	3	Aço NB 1020 Ø16x232
22	Coroaço	1	Aço NB 1020	9	Contorno	2	L. 1 1/4" x 1 1/4" x 1/4"
21	Coroa	1	Aço NB 1030	8	Porca sextavada	6	Ø1/4" x 16
20	Paraf. cob. sext.	16	Ø1/4" x 25	7	Apelo do eixo	2	Aço NB 1020
19	Chaveta	1	Paralelo 14 x 9	6	Eixo do tambor	1	Aço NB 1020
18	Encosto	2	Aço NB 1020 630x6	5	Paraf. cob. sext.	8	Ø1/4" x 1/2"
17	Punho do manivela	1	Aço NB 1020 Ø100x1" x 262	4	Contraco	1	Aço NB 1030 Ø67x22
16	Eixo do cabo	1	Aço NB 1020	3	Treva	1	Aço NB 1030
15	Briga do manivela	1	Aço NB 3525 AF	2	Pino do travo	1	Aço NB 1030 Ø12x90
14	Paraf. cob. quad.	1	Ø1/4" x 10	1	Avul estético	1	Dia Ø12
				Nº	DE NOMINAÇÕES	MATERIAL E DIMENSÕES	

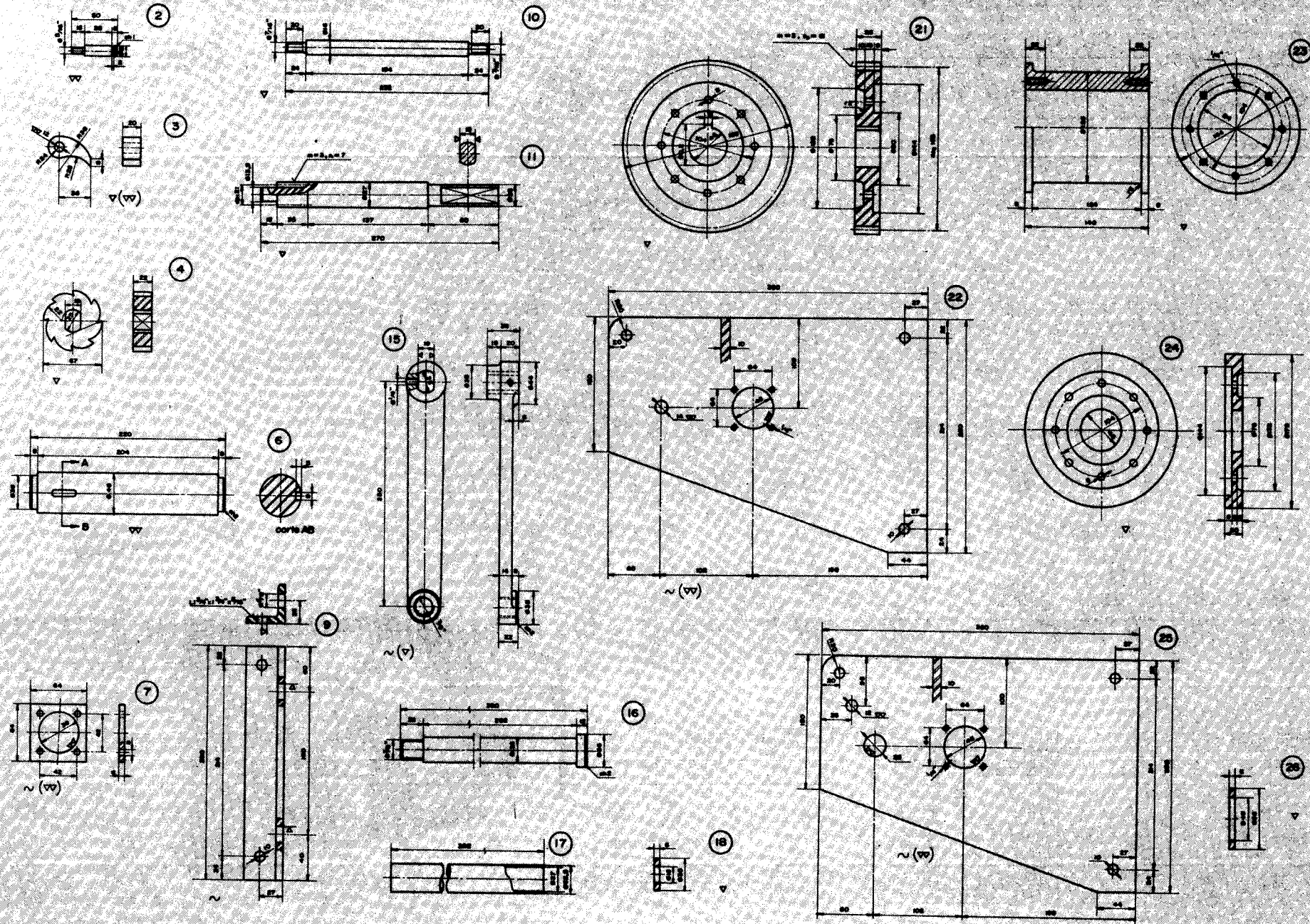

ELEVADOR TRANSPORTADOR

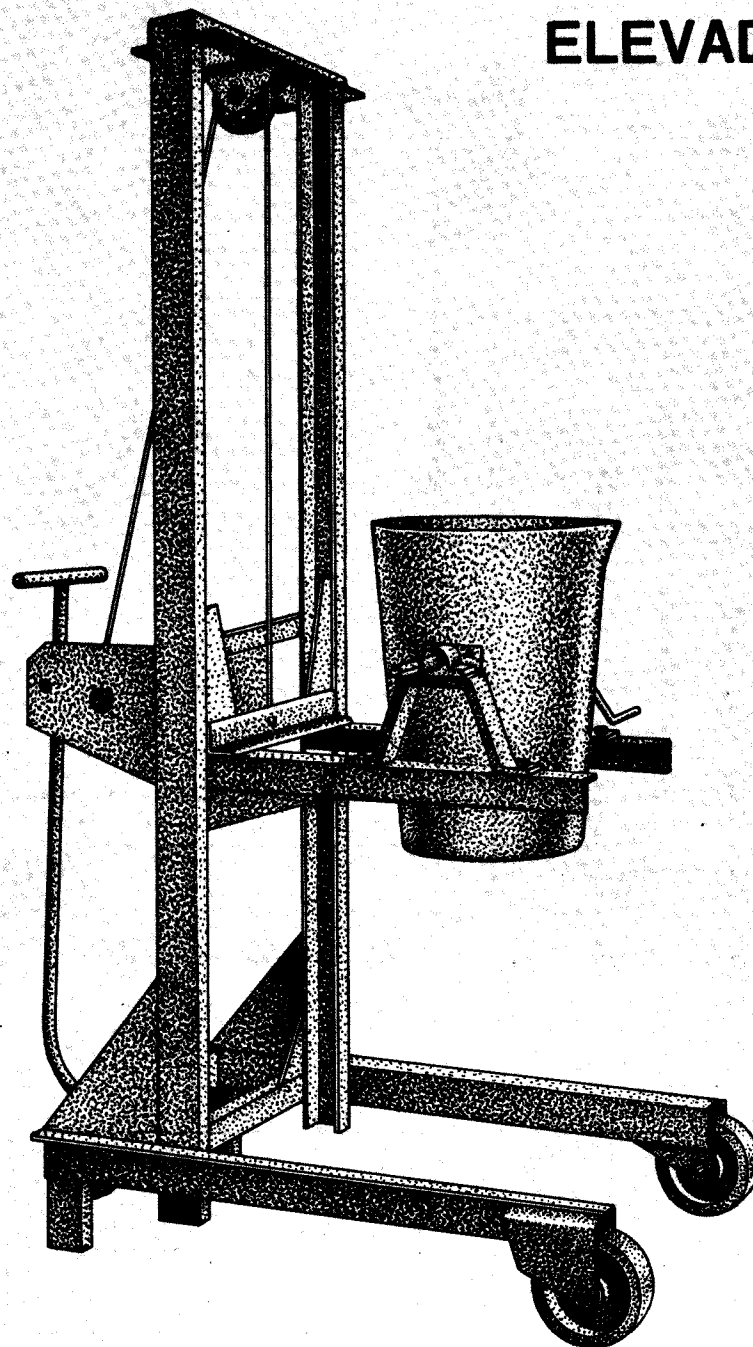

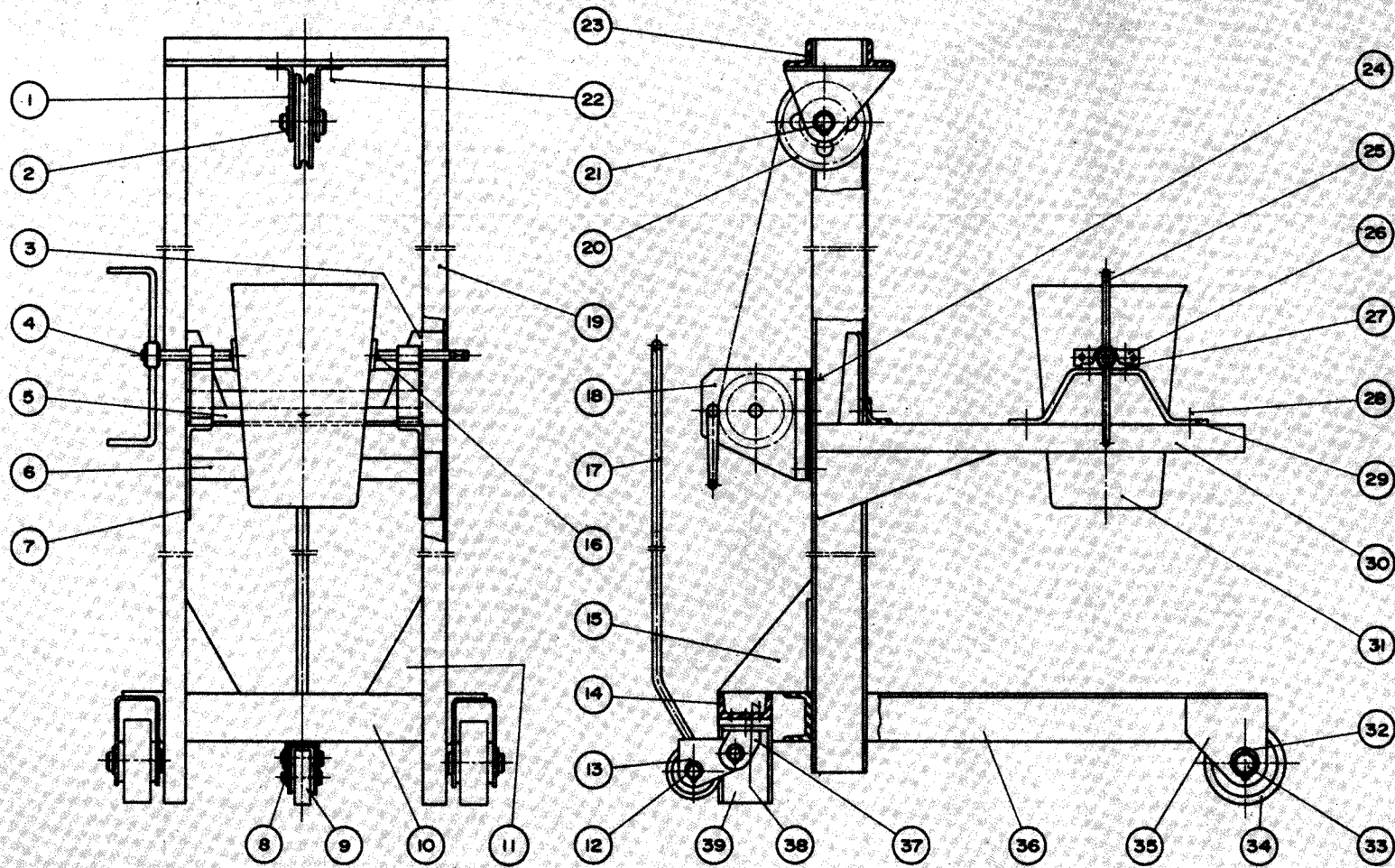

39	Viga	2	C 4"x3"x 5/16"x180
38	Paraf. e porca	4	3/2"
37	Rodillo giratório	1	
36	Cont. cabos desq.	2	L 4"x3"x 5/16"x 980
35	Suporte	2	Chapa B6 2
34	Roda maior	2	Ferro fundido Ø100x70
33	Eixo maior	2	Aço NB 1020
32	Anel elástico	2	DAs 40
31	Balão	1	Aço NB 1020
30	Contornato	2	L 2"x2"x 5/16"x 800

29	Sup. do balão	2	Aço NB 1020
28	Paraf. e porca	8	3/2"
27	Mancal	2	Ferro fundido
26	Chapa	2	Aço NB 1020
25	Cabe	1	Aço NB 1020
24	Paraf. e porca	4	3/2"
23	Contornato	2	L 2"x2"x 5/16"x 530
22	Paraf. e porca	4	3/2"
21	Eixo do polo	1	Aço NB 1020
20	Pala p/ cabo	1	Ferro fundido Ø 100

18	Viga	2	C 4"x1 5/8"x 5/16"x1720
17	Sorbo	1	PV carga de 250kg
16	Alavanco	1	Aço NB 1020 Ø 1/2"
15	Rabita	4	3/16"
14	Refringo	2	Chapa B6 3-0
13	Viga	1	C 4"x1 5/8"x 5/16"x 850
12	Suporte móvel	1	Chapa B6 6
11	Anel elástico	2	DAs 40
10	Refringo	2	Chapa B6 3-0
9	Viga	1	C 4"x1 5/8"x 5/16"x 880

8	Roda menor	1	Ferro fundido Ø100x40
7	Eixo menor	2	Aço NB 1020
6	Sup. p/ eixo	2	Chapa B6 3-0
5	Sup. p/ eixo	2	Aço NB 1020 1"x1/4"x 830
4	Contornato	1	L 2"x2"x 5/16"x 480
3	Eixo do balão	2	Aço NB 1020
2	Suporte superior	2	Chapa B6 5-0
1	Anel elástico	1	DAs 24
	Suporte do polo	2	Chapa B6 2
NR DENOMINAÇÕES		MATERIAL E DIMENSÕES	

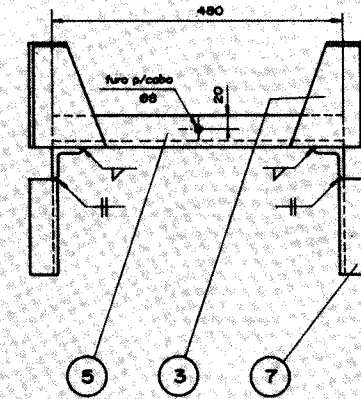
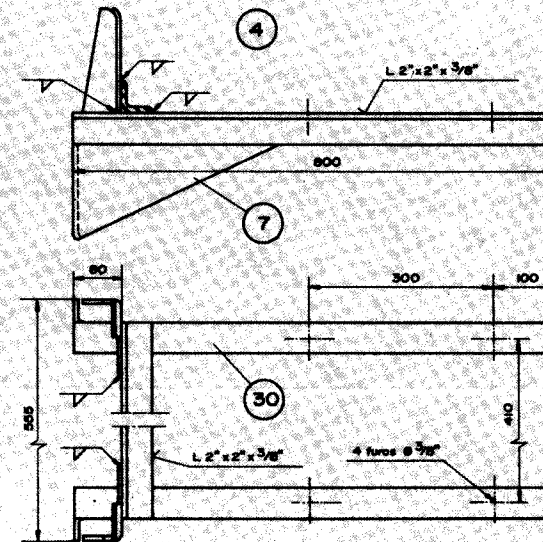
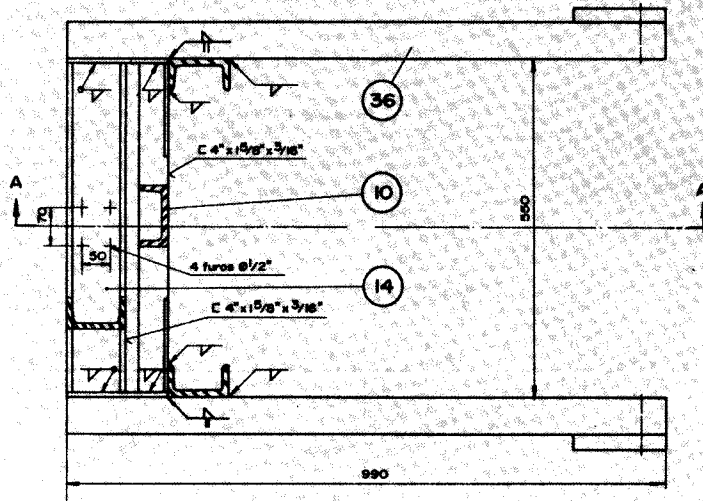
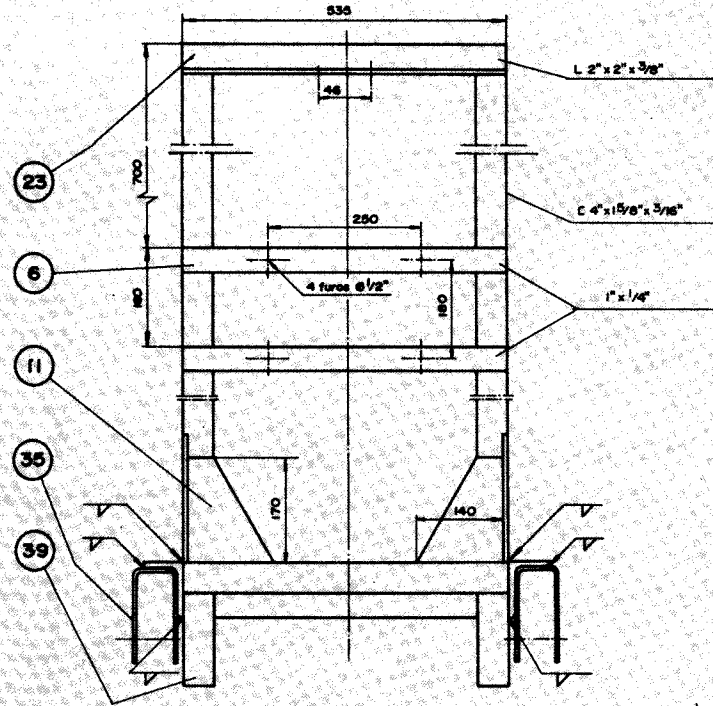
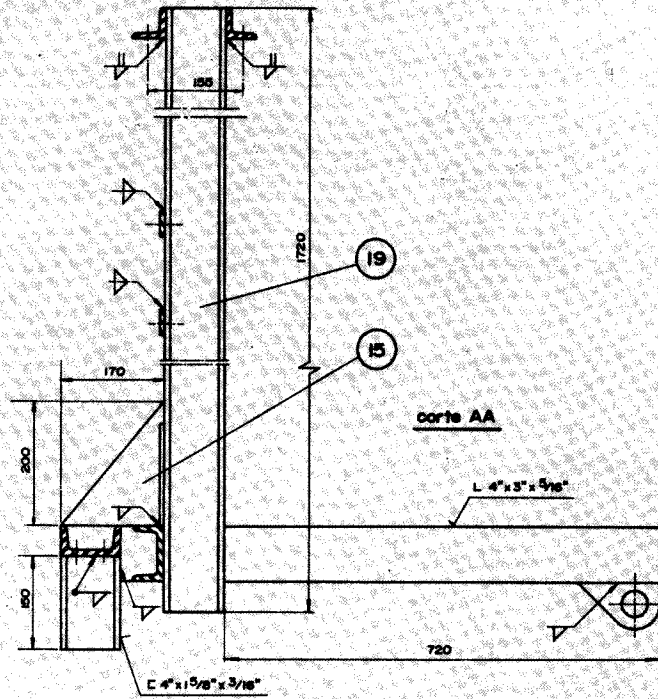

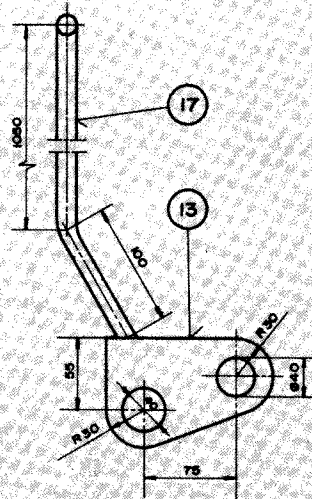
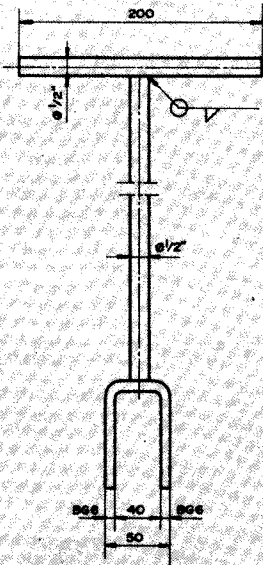
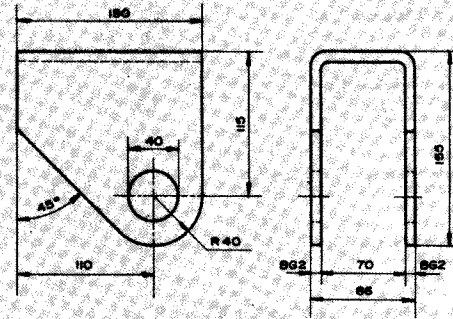
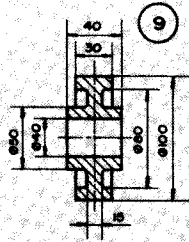
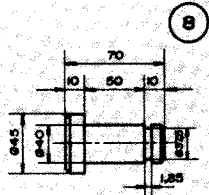
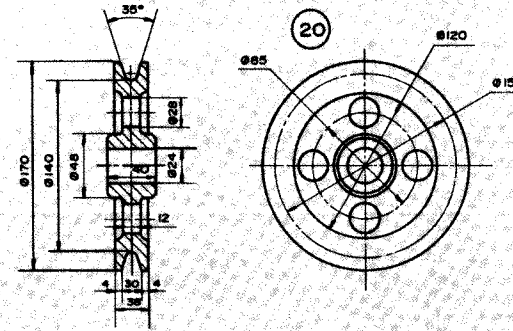
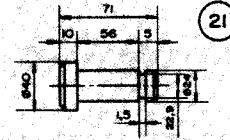
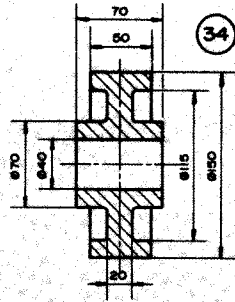
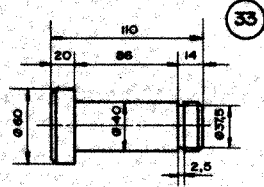

3 A sapata da esquerda é idêntica à da direita com exceção da aba mg nor que é dobrada em sentido oposto.

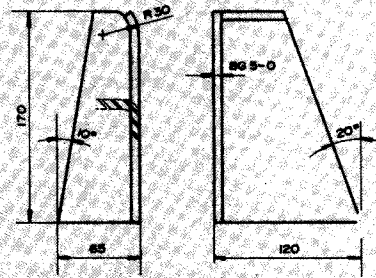

1 O suporte da direita é idêntico ao da esquerda com exceção da aba menor que é dobrada em sentido contrário.

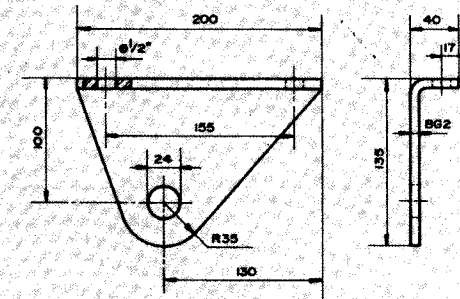

TRANSPORTADOR AÉREO

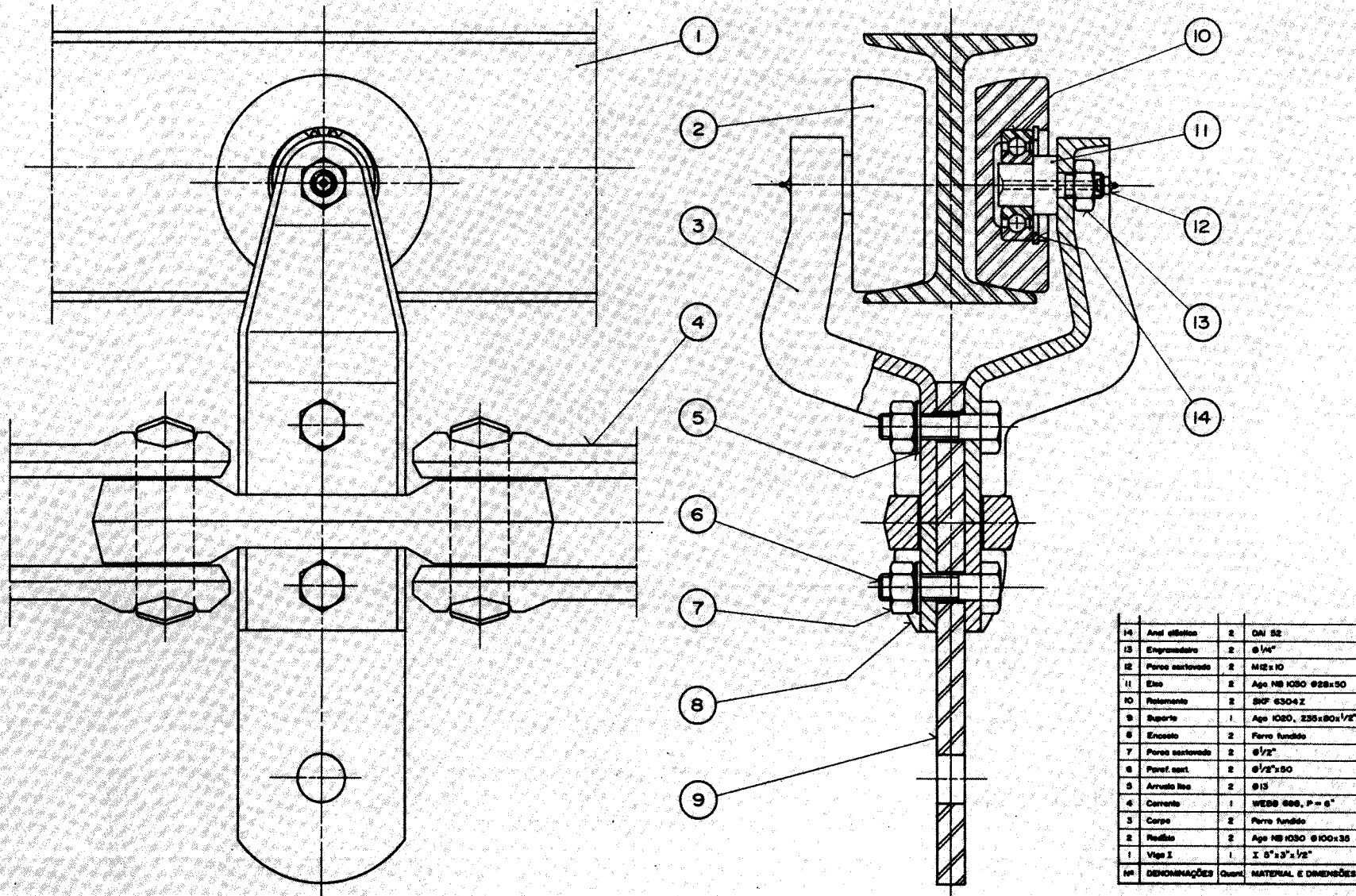

Nº	DENOMINAÇÕES	Quant	MATERIAL E DIMENSÕES
14	Anel elástico	2	DN 52
13	Empilhadeira	2	Ø 1/4"
12	Paraf. esmerilhado	2	M12 x 10
11	Eixo	2	Aço NB 1030 Ø28x50
10	Rolamento	2	SNF 6304 Z
9	Supporto	1	Aço 1020, 235x80x1/2"
8	Encaixe	2	Ferro fundido
7	Paraf. esmerilhado	2	Ø 1/2"
6	Paraf. ext.	2	Ø 1/2" x 50
5	Arruela hex	2	Ø 13
4	Corrente	1	WEISS 600, P = 6"
3	Corpo	2	Ferro fundido
2	Porca	2	Aço NB 1030 Ø100x35
1	Viga I	1	I 8"x3"x1/2"

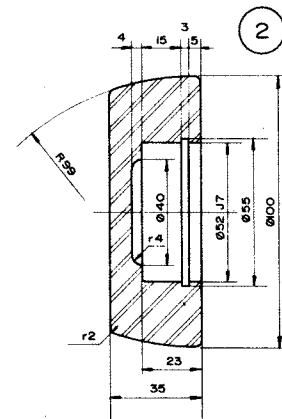
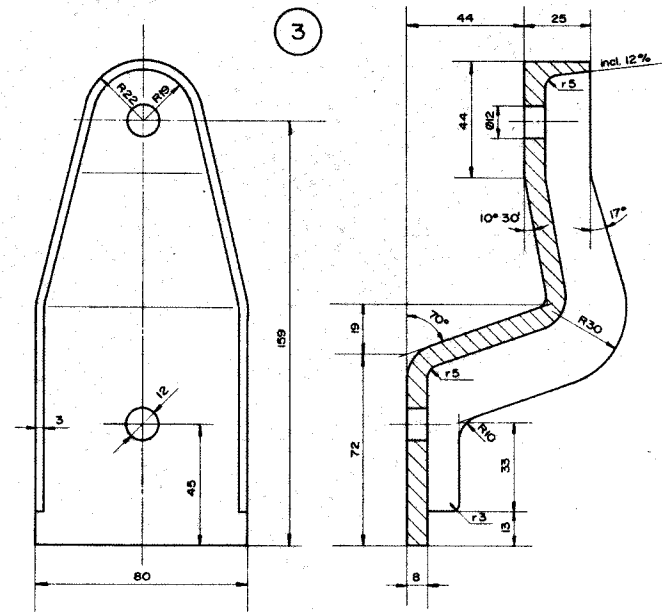
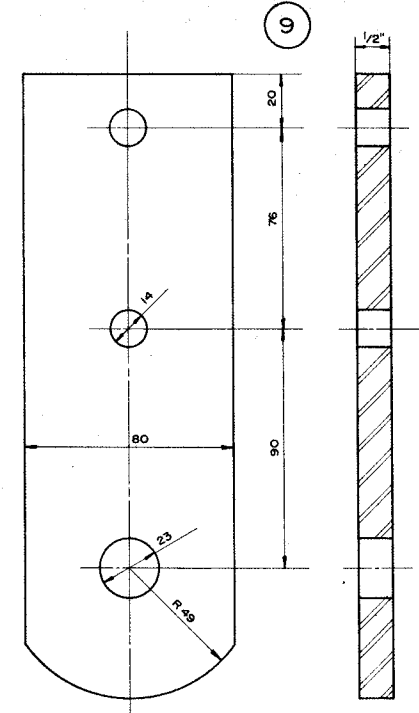
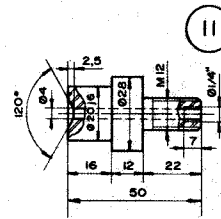
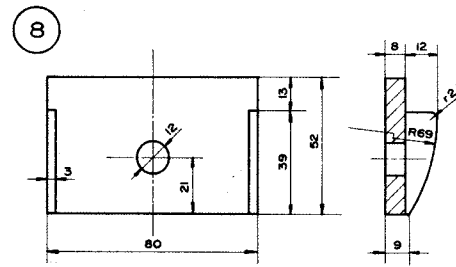
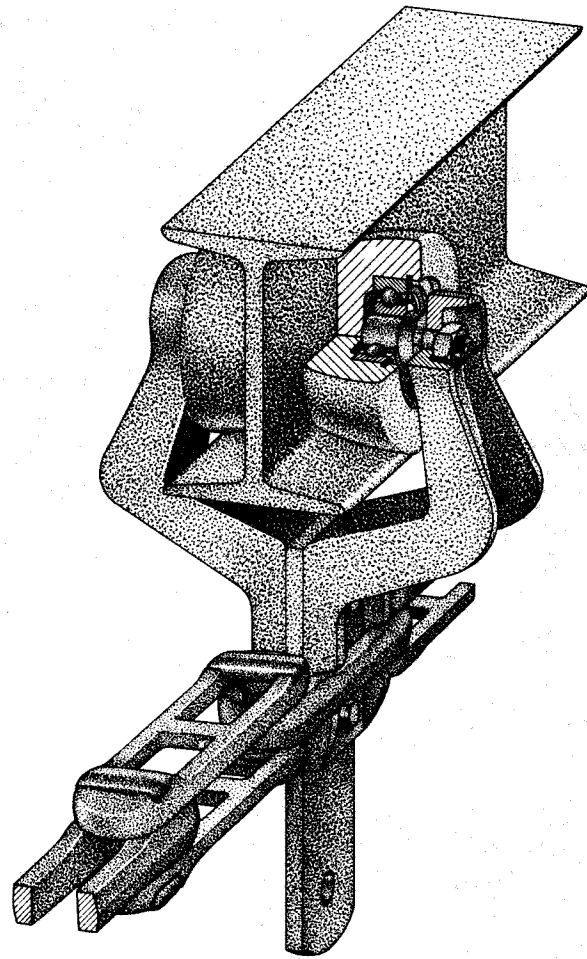

TROLE ACIONADO POR CORRENTE

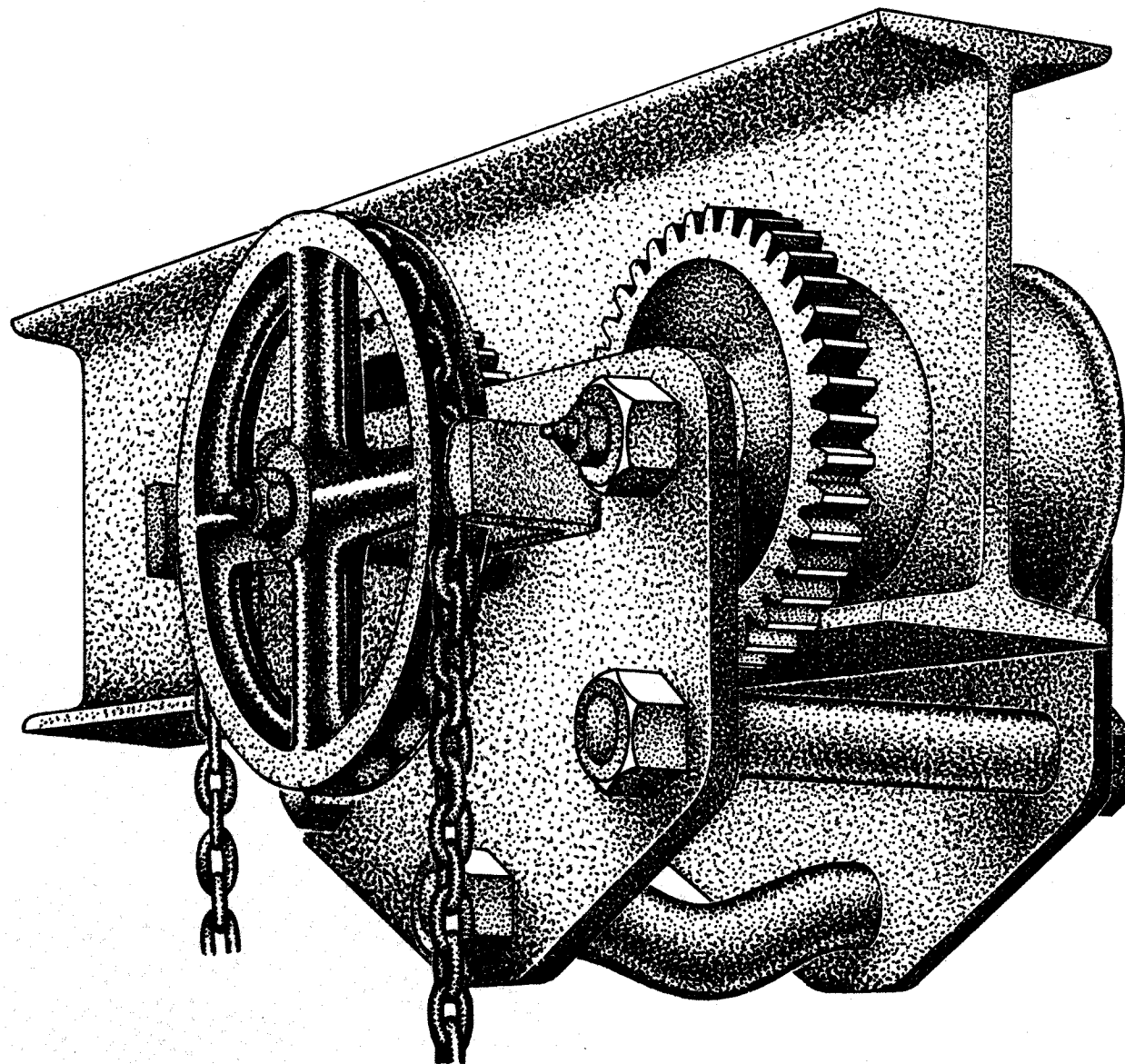

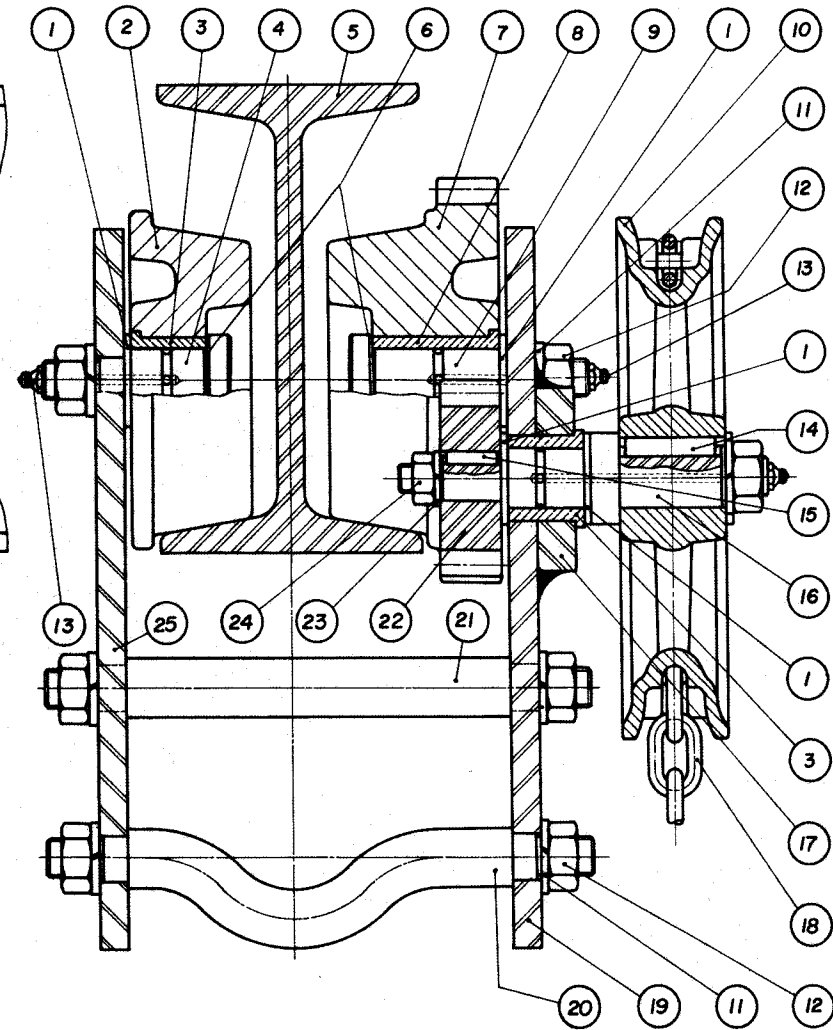
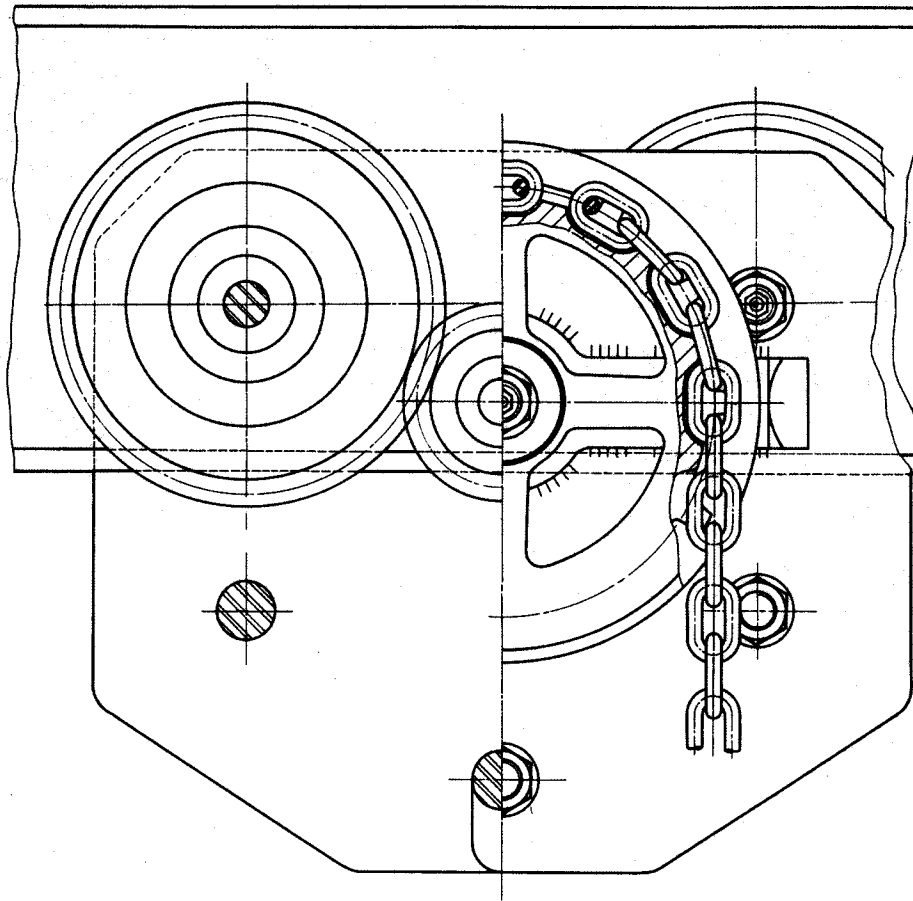

25	Lateral	1	Aço NB 1010 270x235x $\frac{3}{8}$ "
24	Parco sextavado	1	$\emptyset \frac{3}{8}$ "
23	Arruela de pressão	1	$\emptyset 12$
22	Engran. dentes retos	1	Aço NB 1020 m=4, z=14
21	Distanciador	2	Aço NB 1010 $\emptyset \frac{3}{4}$ "x181
20	Travas de suspensão	1	Aço NB 1010 $\emptyset \frac{3}{4}$ "x181
19	Lateral	1	Aço NB 1010 270x235x $\frac{3}{8}$ "
18	Corr. calibrado elo comprido	5m	Ferro d=5, P=17,5

17	Chapa de reforço	1	Aço NB 1010
16	Eixo	1	Aço NB 1050 $\emptyset 30 \times 123$
15	Chaveta	1	Aço NB 1020 17x5x5
14	Chaveta	1	Aço NB 1020 30x6x6
13	Engraxadeira	5	Latão $\emptyset \frac{1}{4}$ gds
12	Parco sextavado	11	$\emptyset \frac{1}{2}$ "
11	Arruela de pressão	11	$\emptyset 15$
10	Polia p/ corrente	1	Ferro fundido esferoidal z=12, d=5, P=17,5
9	Eixo	2	Aço NB 1050 $\emptyset 30 \times 79$

Nº	DENOMINAÇÕES	QTD	MATERIAL E DIMENSÕES
8	Bucha	2	Bronze SAE 660 $\emptyset 32 \times 42$
7	Roda com engran.	2	Ferro fundido esferoidal m=4 z=31
6	Arruela torneada	4	$\emptyset 28 \times \emptyset 20,5 \times 1$
5	Viga dupla I	1	I 6"x3 $\frac{3}{8}$ "
4	Eixo	2	Aço NB 1050 $\emptyset 30 \times 62$
3	Bucha	3	Bronze SAE 660 $\emptyset 32 \times 25$
2	Roda	2	Ferro fundido esferoidal 80x40
1	Arruela torneada	6	$\emptyset 30 \times \emptyset 20,5 \times 2$
Nº	DENOMINAÇÕES	QTD	MATERIAL E DIMENSÕES

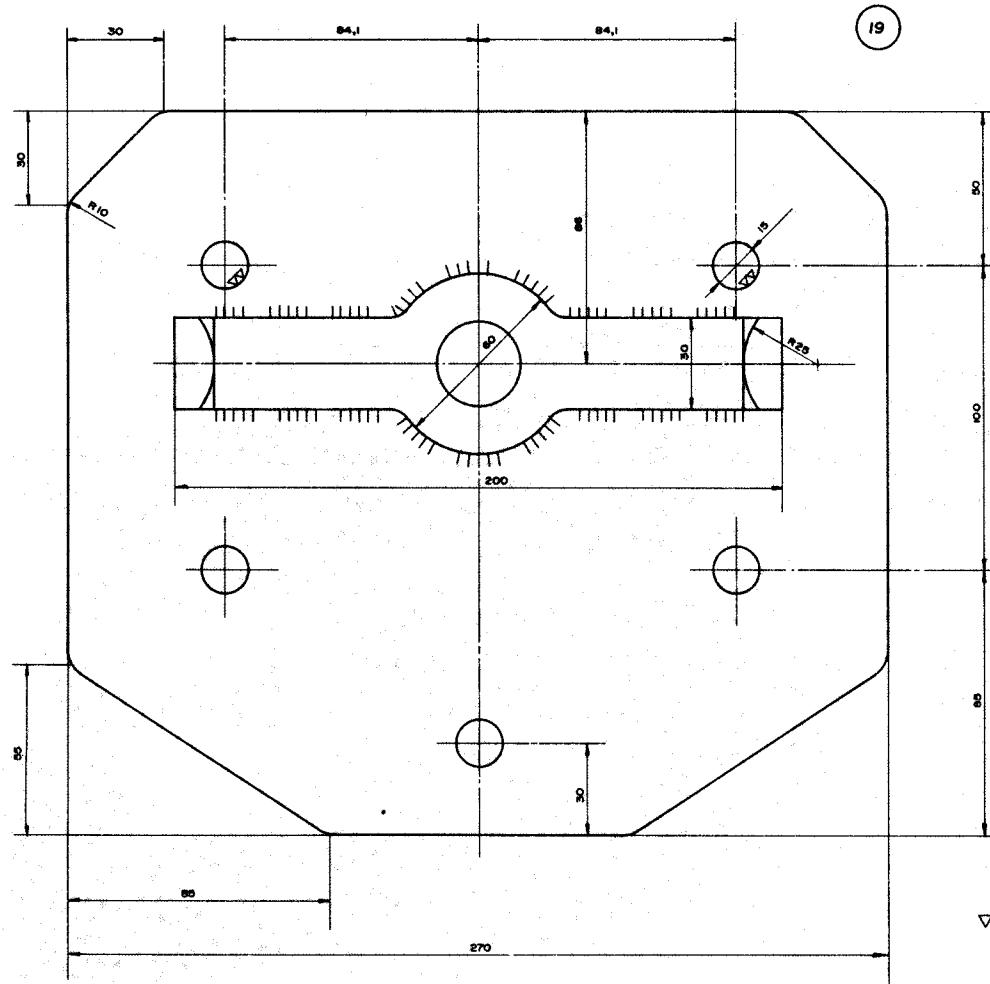

19

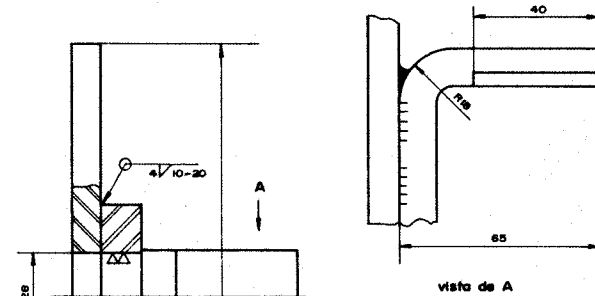

17

3

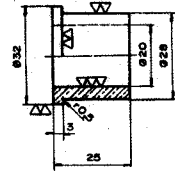

∇ (∇, ∇∇)

8

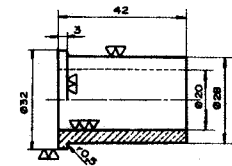

∇ (∇, ∇∇)

A peça (25) é idêntica à (19) porém sem o furo de Ø 28 e o correspondente reforço (17)

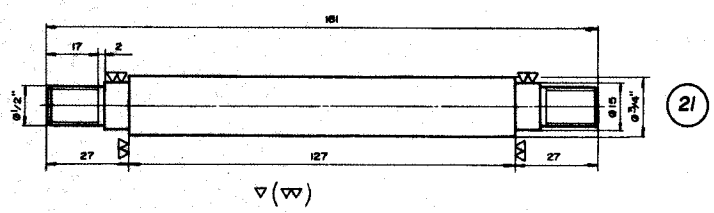

21

∇ (∇)

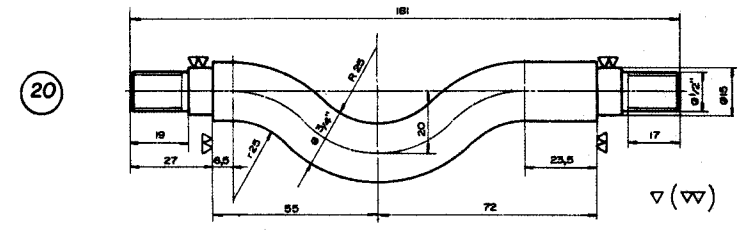

20

∇ (∇)

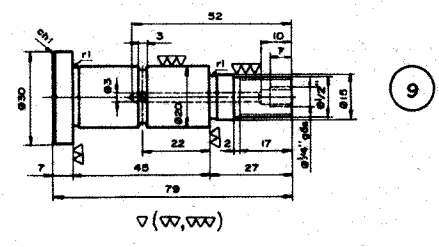
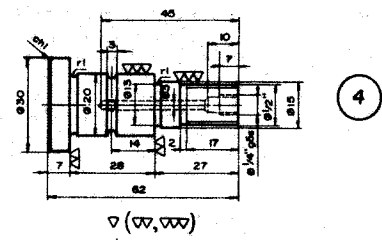
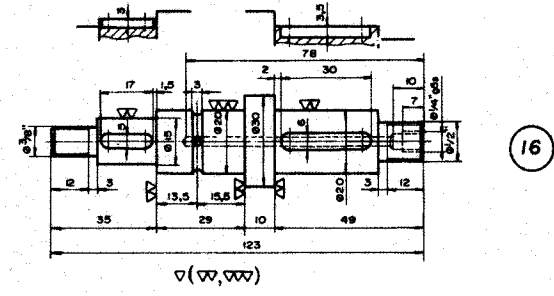
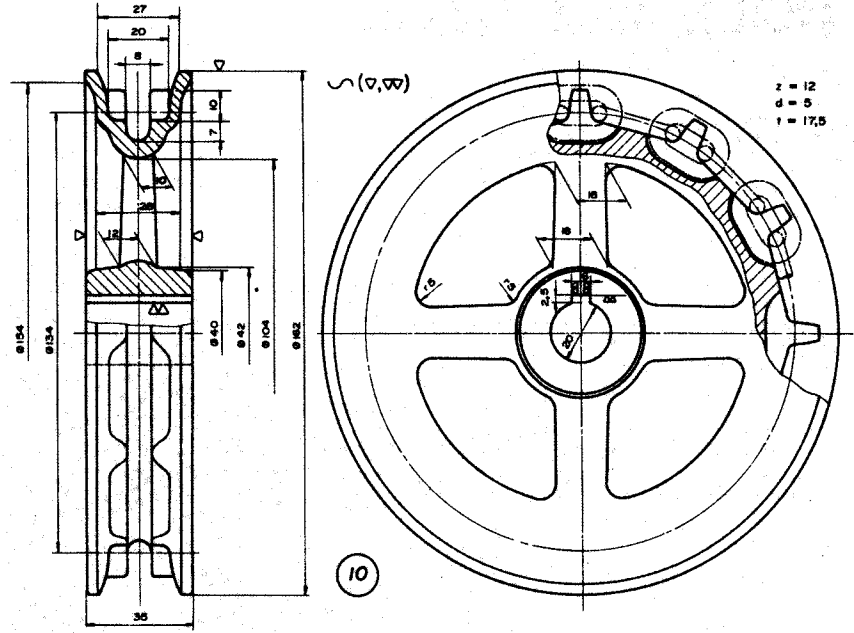
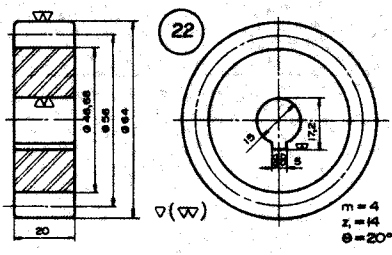
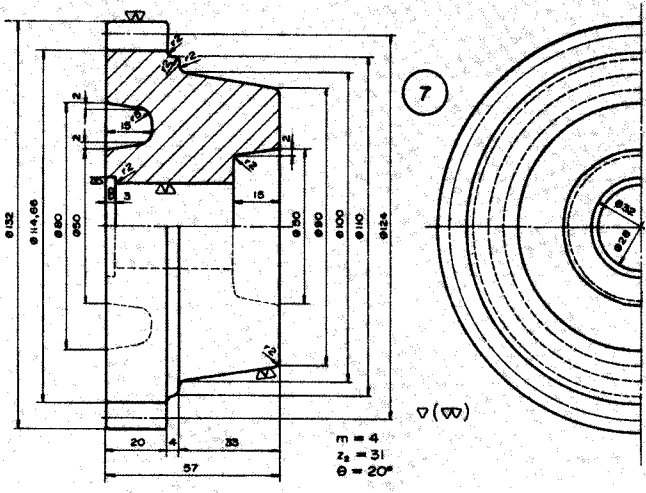
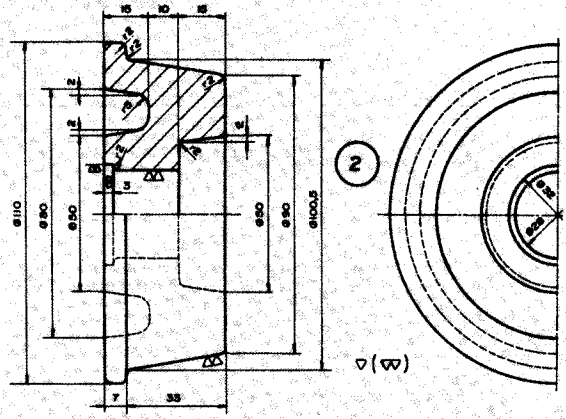

TROLE ELÉTRICO

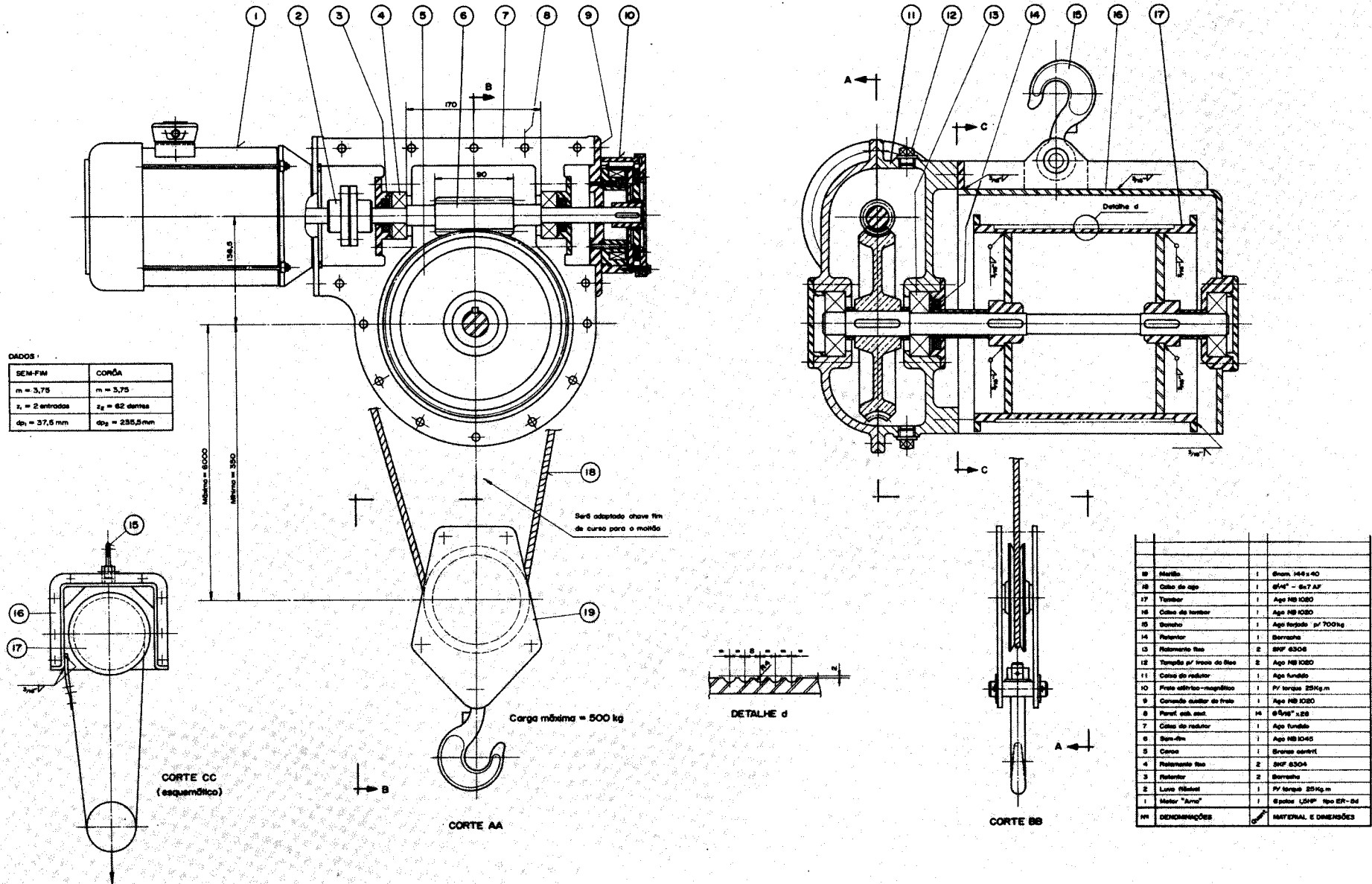

DADOS

SEM-FIM	CORDEA
m = 3,75	m = 3,75
z ₁ = 2 entradas	z ₂ = 62 dentes
dp ₁ = 37,5 mm	dp ₂ = 235,5 mm

17	Marrão	1	Ømm 144 x 40
16	Cabo de aço	1	Ø7/8" - 6x7 AF
15	Tambor	1	Aço HB 1020
14	Cabo de tambor	1	Aço HB 1020
13	Bornão	1	Aço forjado pr 700kg
12	Parafuso	1	Bornão
11	Platamento fino	2	SF 6306
10	Temperado pr' freio de base	2	Aço HB 1020
9	Cabo do roldão	1	Aço fundido
8	Fretos esférico-magnético	1	FV torque 25kg.m
7	Conexão isolador de freio	1	Aço HB 1020
6	Paraf. com. est.	14	Ø5/8" x 25
5	Cabo do roldão	1	Aço fundido
4	Bornão	1	Aço HB 1045
3	Carro	1	Bronze aderente
2	Platamento fino	2	SF 6304
1	Parafuso	2	Bornão
	Luzo Rileast	1	FV torque 25kg.m
	Motor "Arno"	1	6 polos LSHF tipo ER-04
	DESCRIÇÕES		MATERIAL E DIMENSÕES

PONTE ROLANTE ACIONADA POR CORRENTE

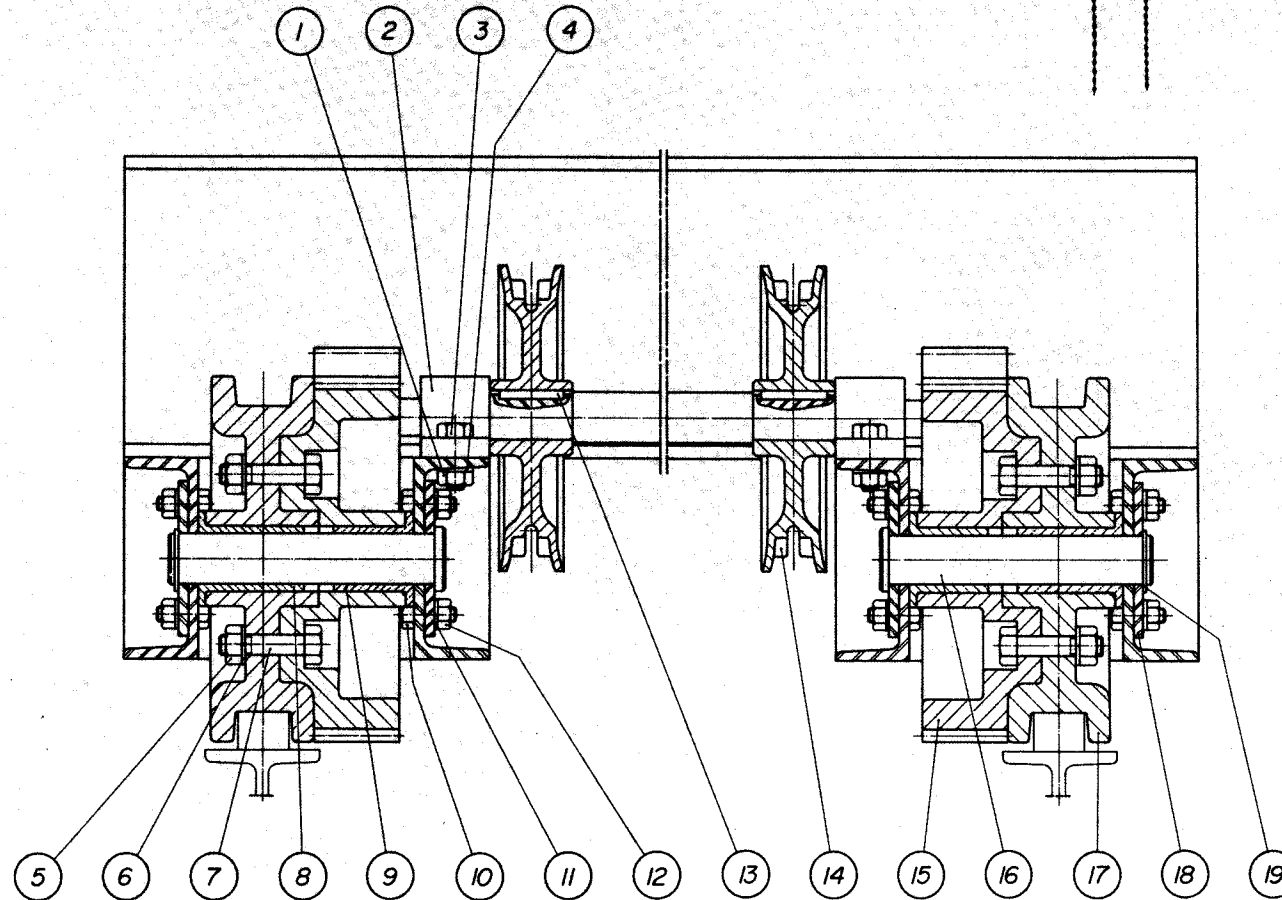
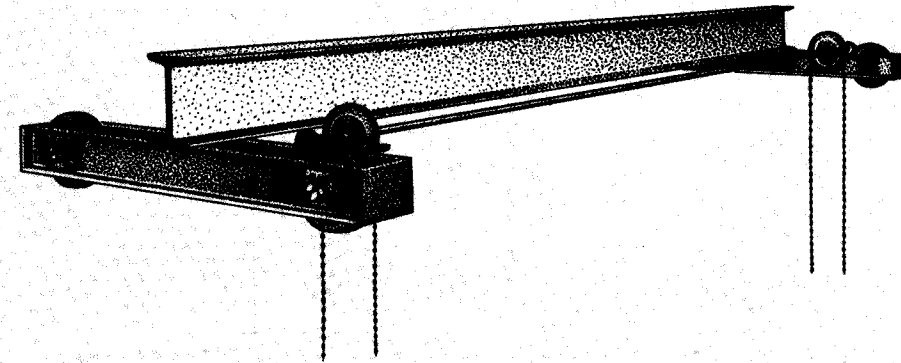

32	Paraf. porca e chap.	Ø	Ø 3/8" x 40
31	Proteção	4	Chapa Ø 3/8" x 150 x 25
30	Anel atômico	2	DAe 36
29	Pinho	2	Aço NB 1020
28	Viga base	2	C 200 x 75 x 8,5
27	Roda	2	Ferro fundido
26	Bucha	4	Bronze SAE 660
25	Viga base	1	C 200 x 75 x 8,5
24	Chav. paralela	2	10 x 6 x 80
23	Eixo	1	Aço NB 1030
22	Viga central	1	I 300 x 125 x 10,8
21	Viga base	2	C 200 x 75 x 8,5
20	Chapa de união	4	Chapa de ferro BG 7-0
19	Anel atômico	4	DAe 50
18	Refrigo	4	Chapa de aço B6 0
17	Roda	2	Ferro fundido
16	Eixo	4	Aço NB 1030
15	Corão	2	Ferro fundido
14	Roda p/ corrente	2	Ferro fundido
13	Chav. paralela	2	12 x 6 x 70
12	Parco sextavado	32	Ø 1/2"
11	Arruela de pres.	32	Ø 1/2"
10	Paraf. cob. sext.	32	Ø 1/2" x 25
9	Bucha	2	Bronze SAE 660
8	Bucha	2	Bronze SAE 660
7	Paraf. cob. sext.	8	Ø 5/8" x 50
6	Arruela simples	8	Ø 5/8"
5	Parco sextavado	8	Ø 3/8"
4	Chapinha	4	Ø 7/8" x 45
3	Paraf. cob. sext.	4	Ø 7/8" x 45
2	Mancal simples	2	Ferro fundido
1	Parco sextavado	4	Ø 7/8"
Nº	DENOMINAÇÕES	MATERIAL E DIMENSÕES	

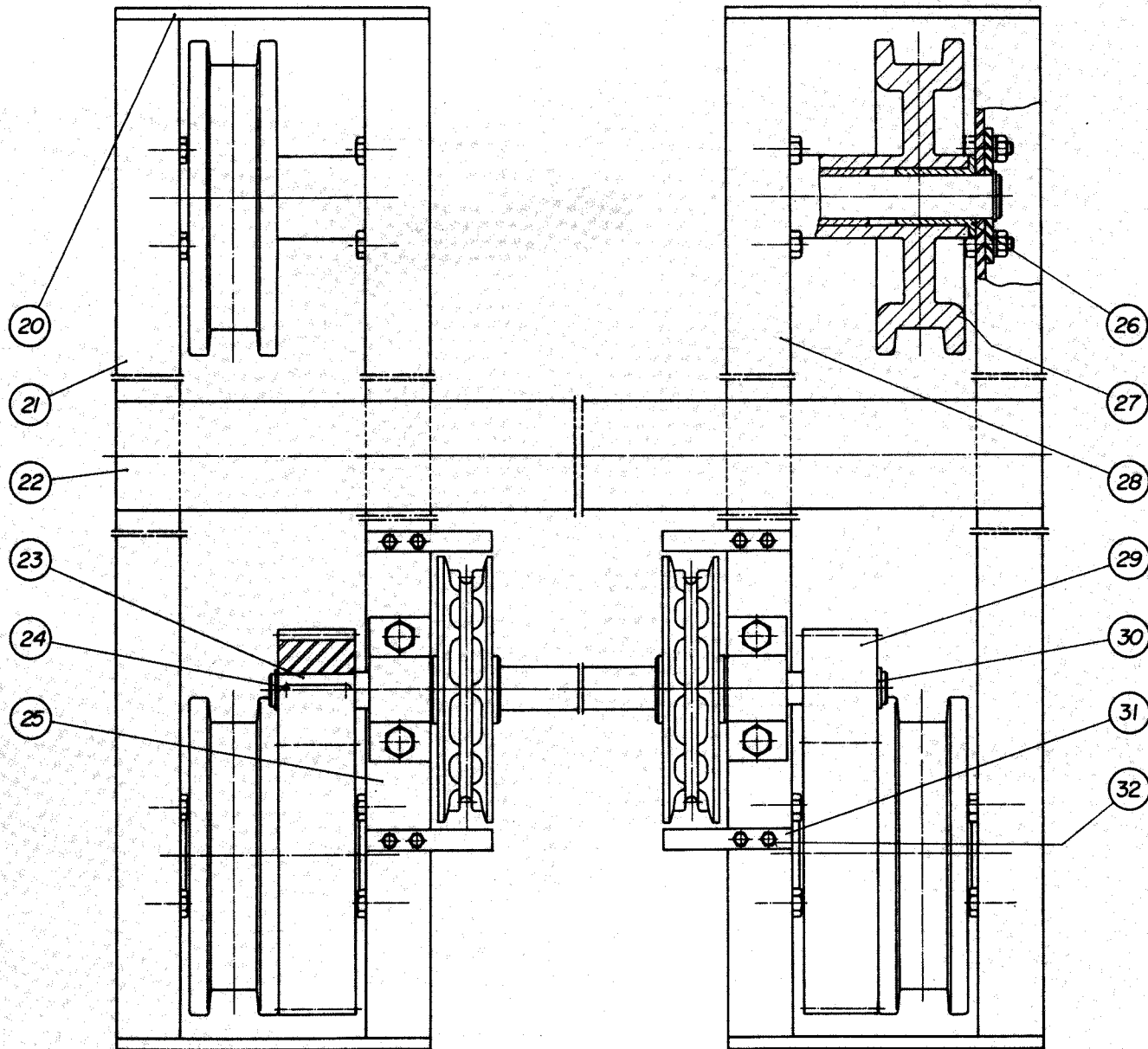

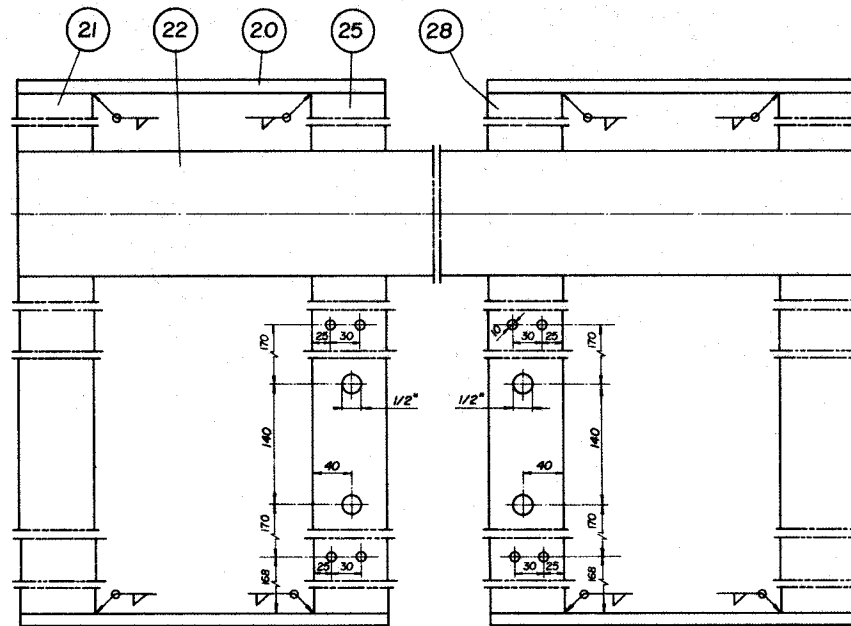
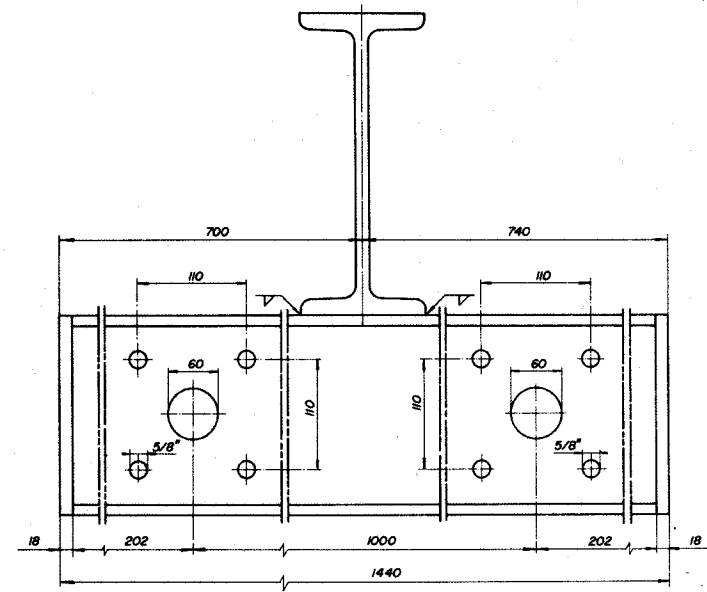
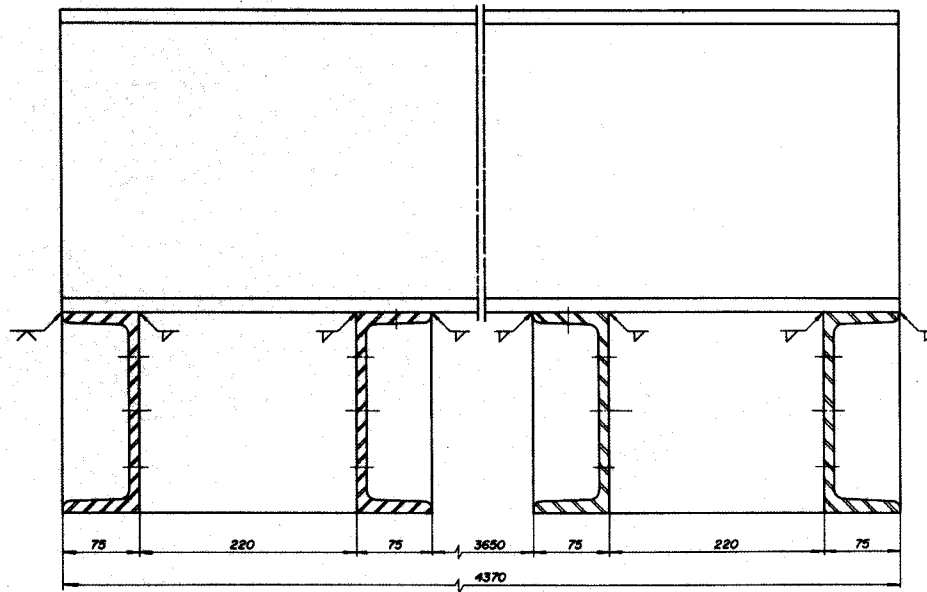

31

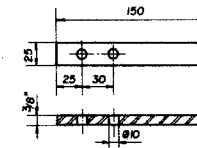

2

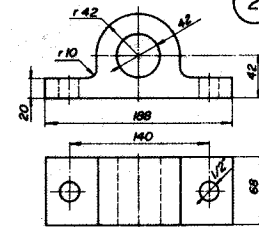

18

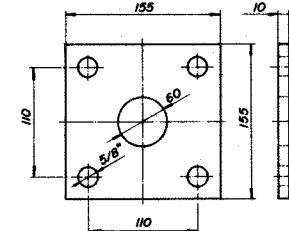

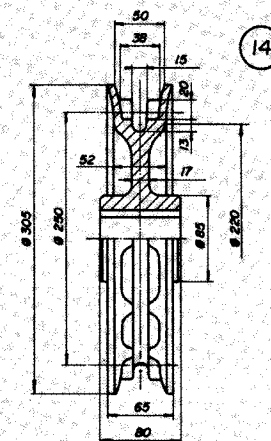
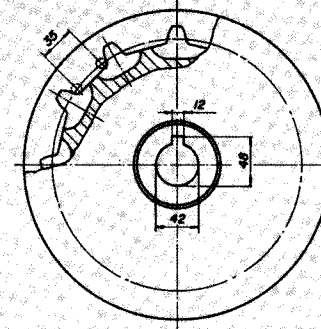
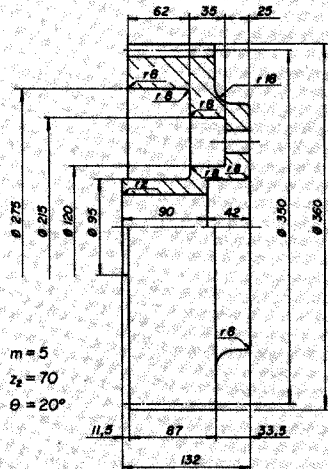
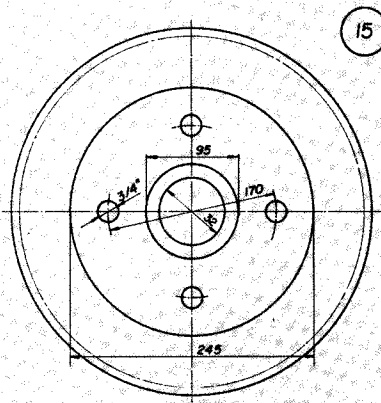
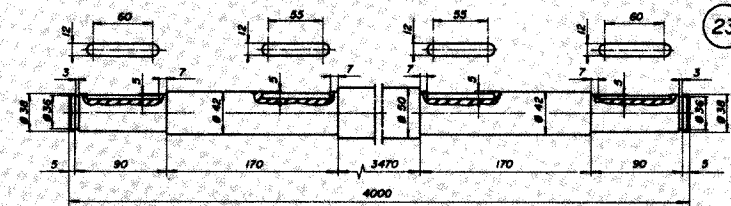
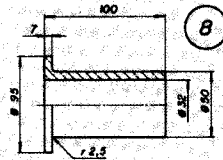
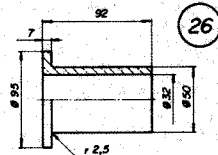
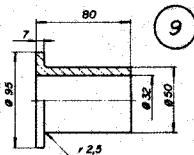
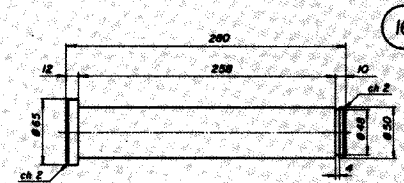
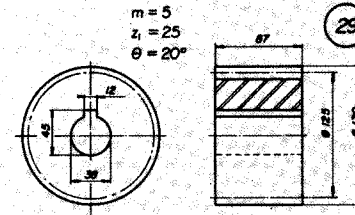
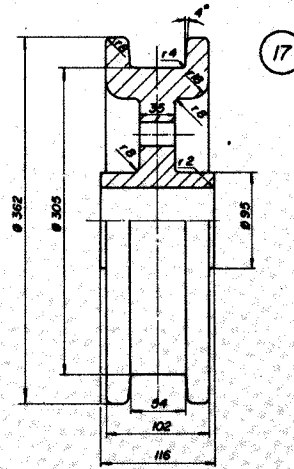
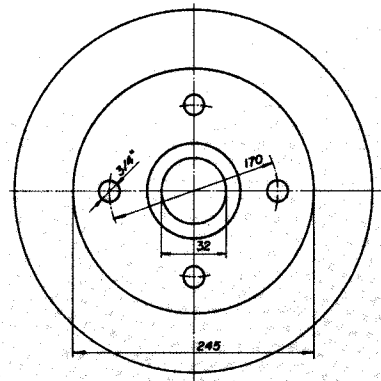
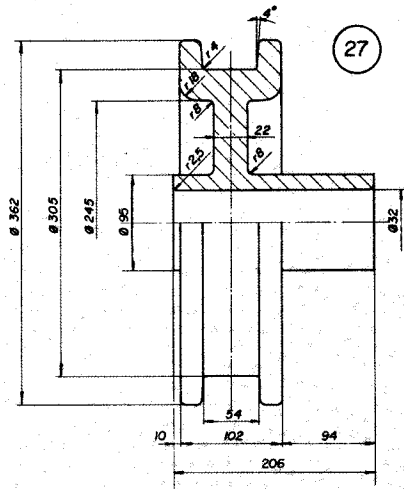

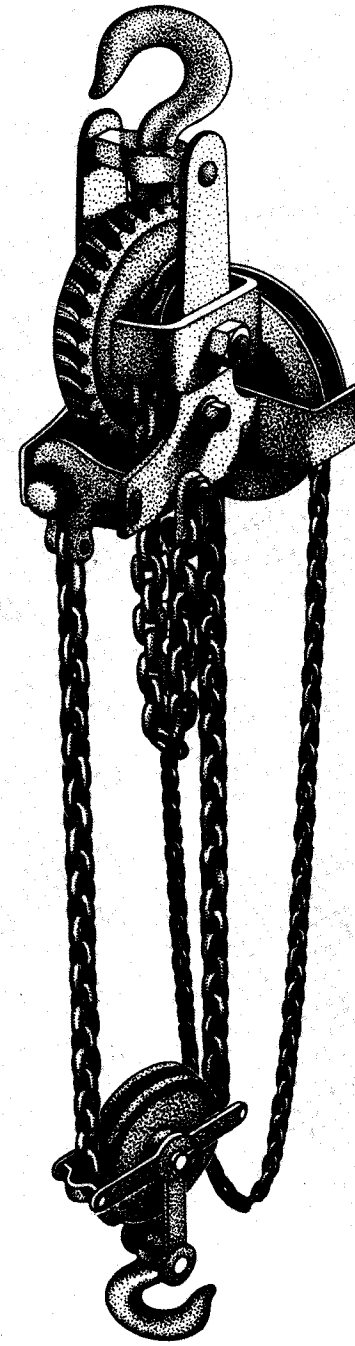
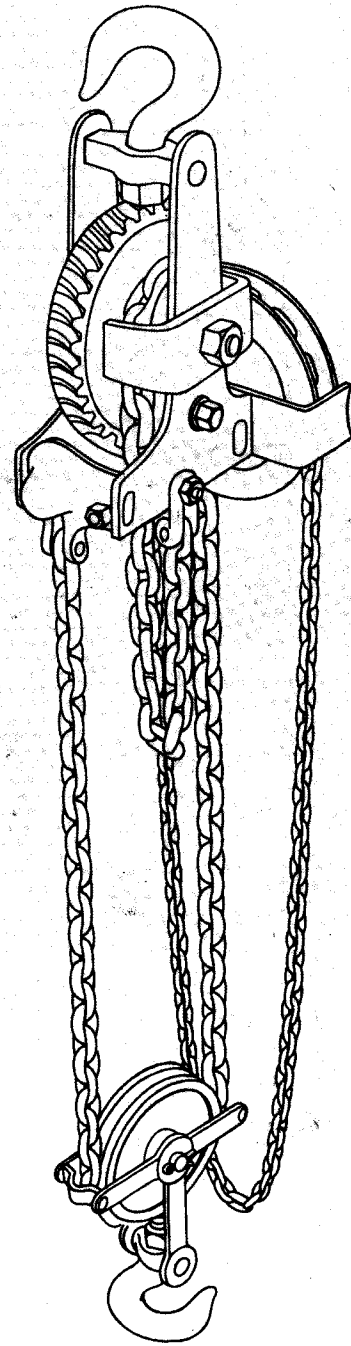
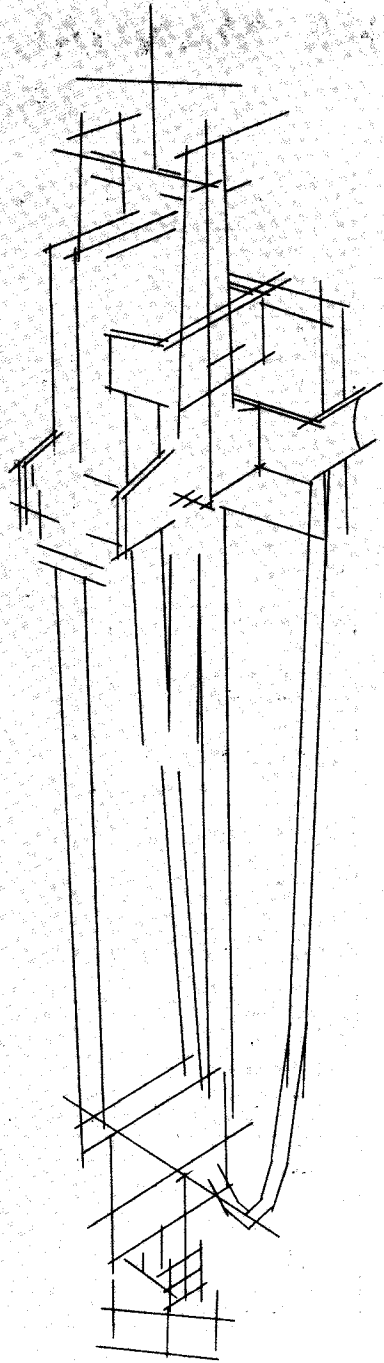

TALHA MANUAL PARA 1500 KG

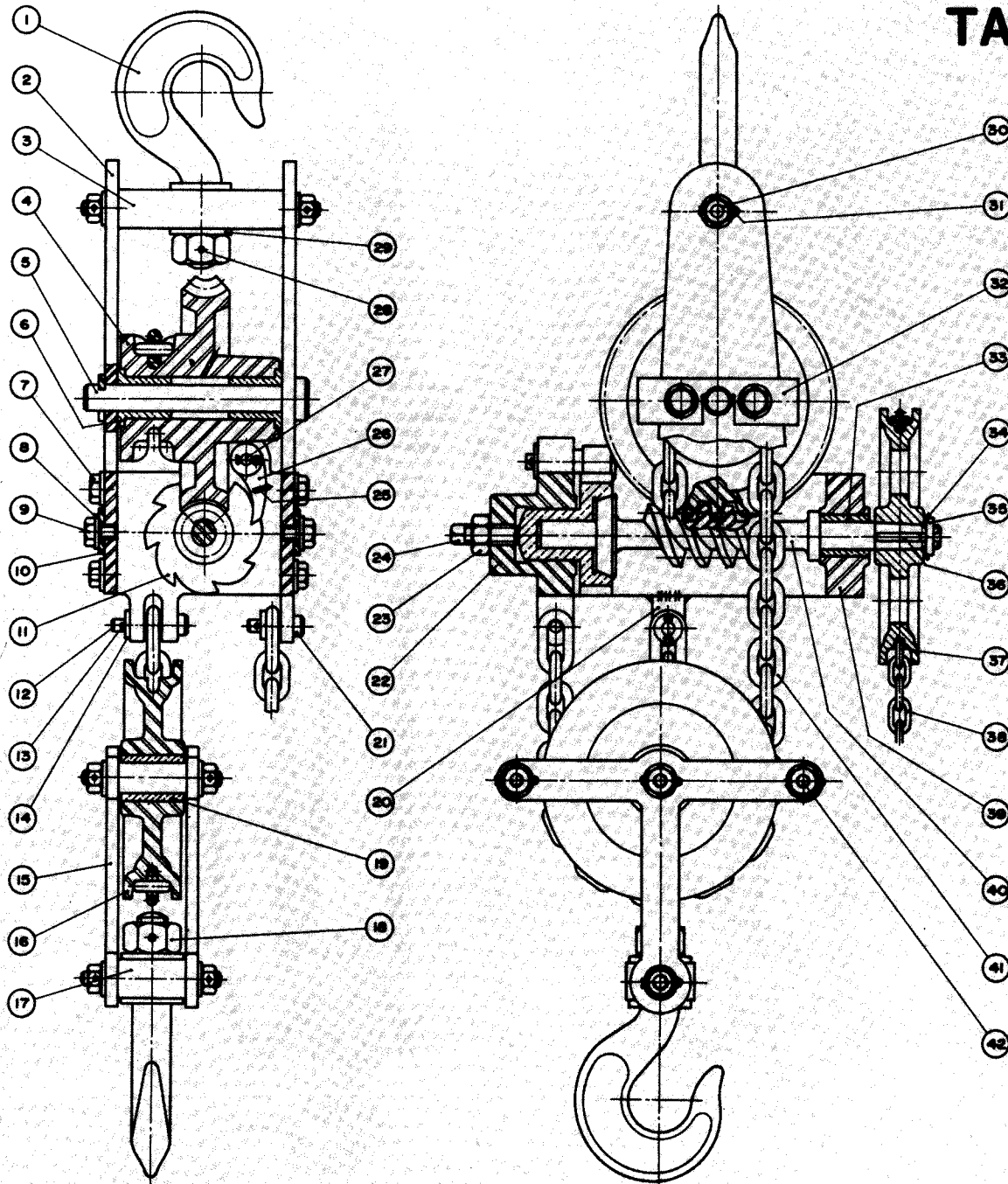

42	Distanciador	3	Aço NB 1030
41	Corrente de aço compr.	—	d = 9,5 t = 24,3
40	Semi-fim	1	Aço NB 1040
39	Menrol	1	Aço NB 3525 AF
38	Corrente de aço compr.	—	d = 5 t = 18,5
37	Polia	1	Ferro fundido
36	Chaveta	1	6x6x40
35	Porca	1	M20x1,5
34	Arruela	1	Latão
33	Bucha	1	Bronze SAE 660
32	Proteção	1	Aço NB 1020 B6 6
31	Cupilha	10	Ø 1/8" x 35
30	Porca sextavada	10	Ø 1/2"
29	Arruela lisa	4	Ø 1"
28	Cupilha	2	Ø 3/16" x 60
27	Eixo	1	Aço NB 1040
26	Tranqueta	1	Aço NB 1040
25	Mola	1	Aço NB 1050
24	Paraf. de fixação	1	Ø 5/8" x 40
23	Porca sextavada	1	Ø 5/8"
22	Menrol	1	Aço NB 3525 AF
21	Pino com cabeça	1	Ø 10 x 25 x 20
20	Orelha	1	Aço NB 1020
19	Bucha	1	Bronze SAE 660
18	Porca sextavada	2	Ø 1"
17	Distanciador	1	Aço NB 1030
16	Polia	1	Ferro fundido
15	Lateral	2	Aço NB 1020 B6 3-0
14	Arruela lisa	2	Ø 10
13	Cupilha	4	Ø 1/8" x 15
12	Pino com cabeça	1	Ø 10 x 45 x 38
11	Catracas	1	Bronze SAE 660
10	Proteção	2	Aço NB 1020 B6 6
9	Paraf. cob. sext.	4	Ø 1/2" x 15
8	Arruela lisa	26	Ø 1/2"
7	Paraf. cob. sext.	8	Ø 1/2" x 30
6	Bucha	2	Bronze SAE 660
5	Eixo	1	Aço NB 1040
4	Coroa	1	Aço NB 3525 AF
3	Distanciador	1	Aço NB 1030
2	Lateral	2	Aço NB 1020 B6 3-0
1	Gancho	2	Aço forjado NB 1030
Nº	DENOMINAÇÕES		MATERIAL E DIMENSÕES

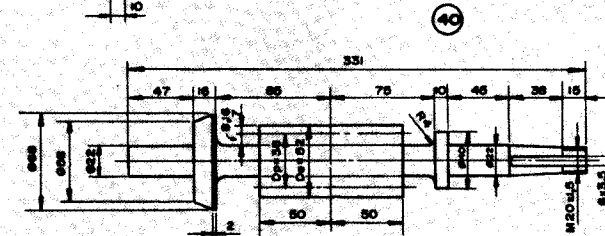
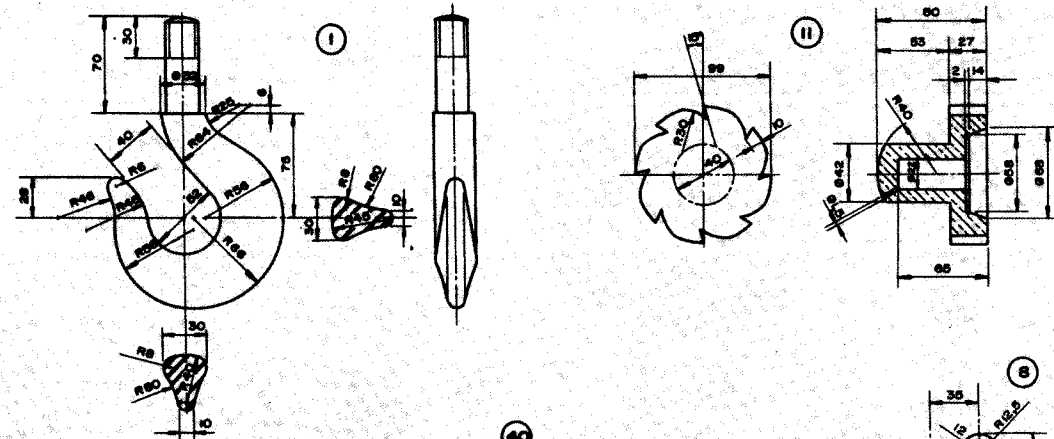
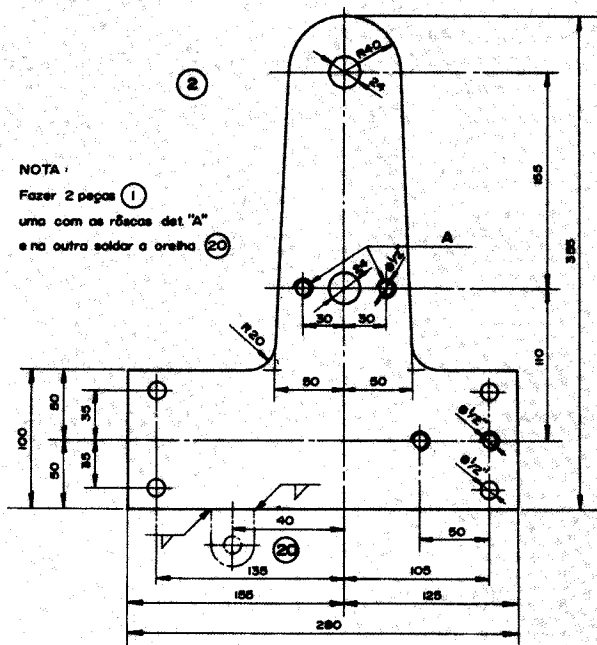

RÔSCA SEMI-FIM DIREITA
 $m = 7, z = 2$ entradas $\theta = 20^\circ 20'$

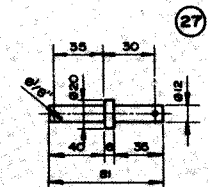
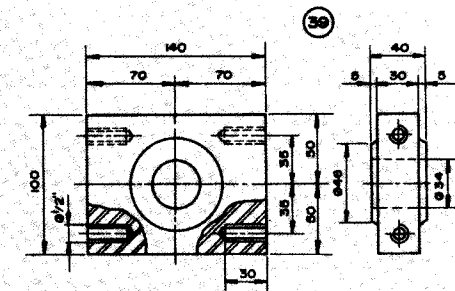
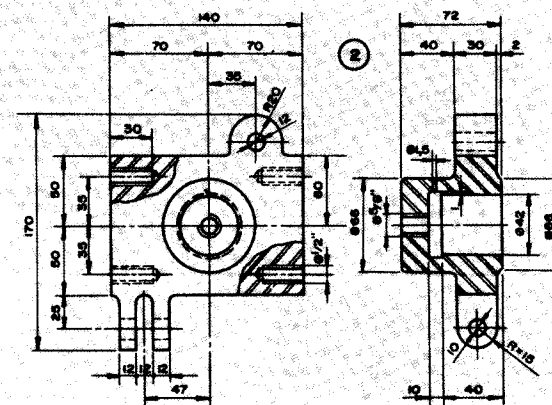
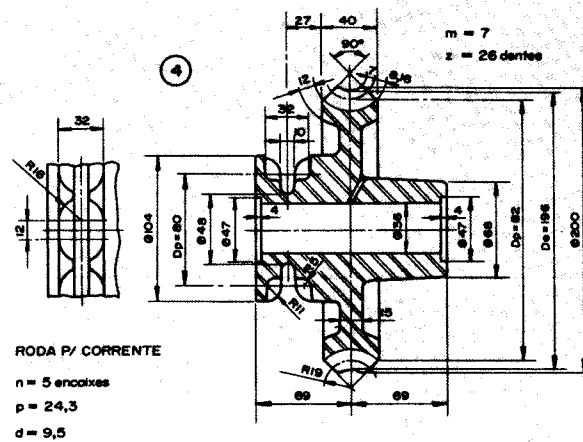
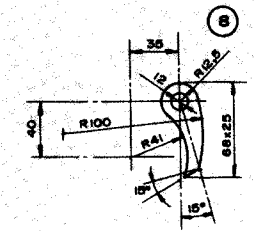

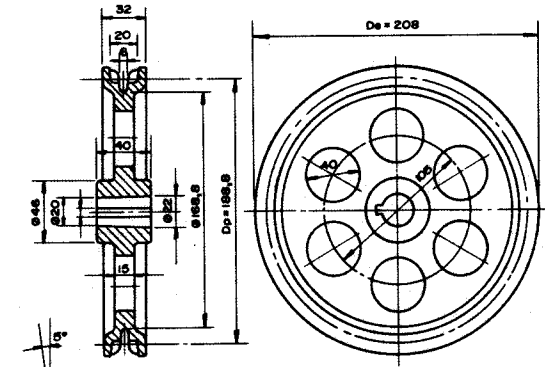

37

RODA P/ CORRENTE

n = 16 encaixes
 p = 18,5
 d = 5

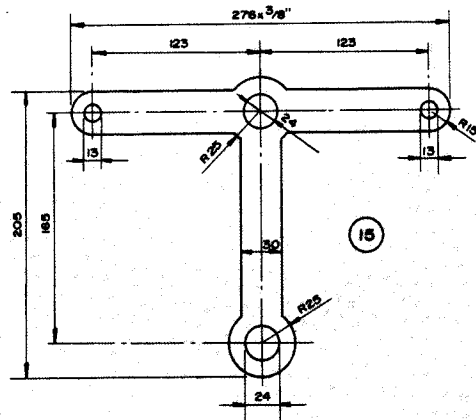

15

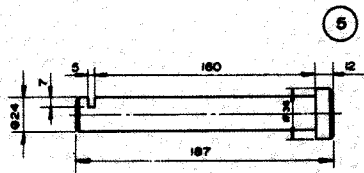

5

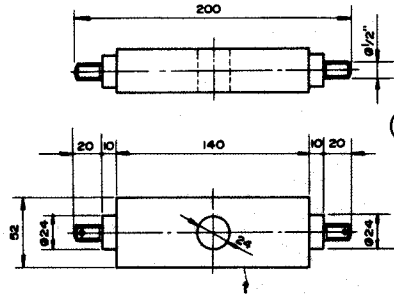

3

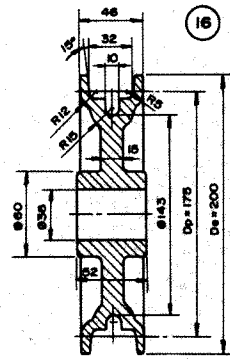

16

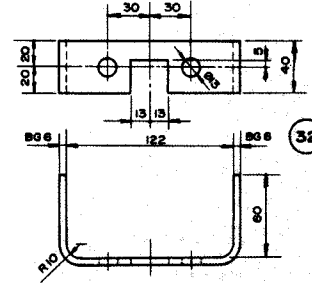

32

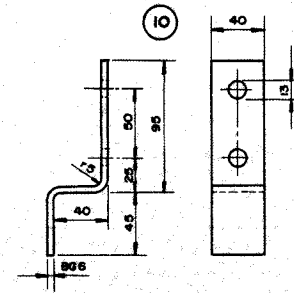

10

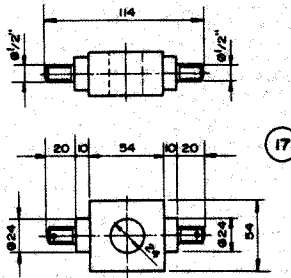

17

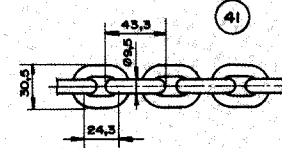

41

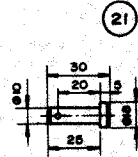

21

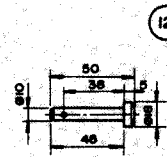

12

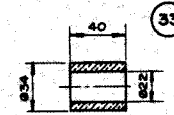

33

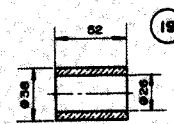

19

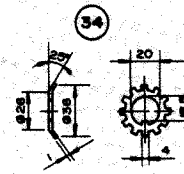

34

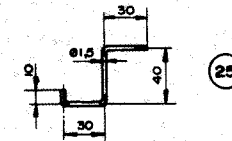

25

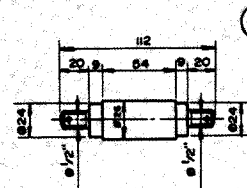

42

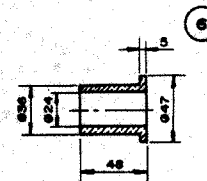

6

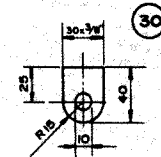

30

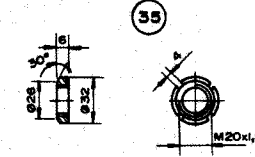

35

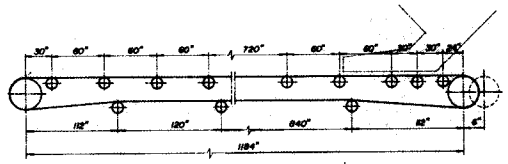
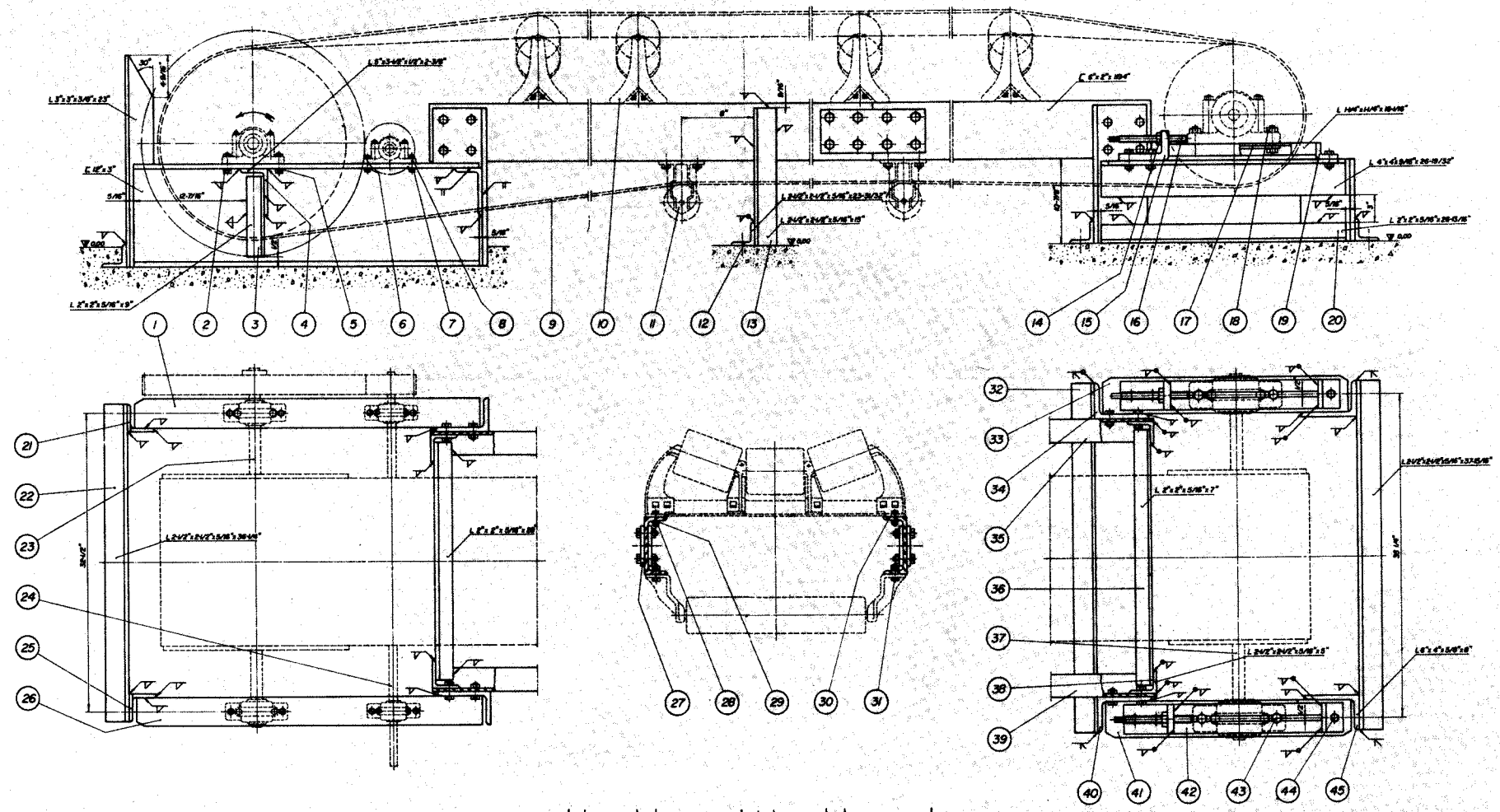

42	Contator	2	L. 4" x 3/8" x 2"	43	Roller fix	1	JEFFREY
44	Paraf. cob. ext.	2	Ø 3/8"	23	Contator	1	L. 2-1/2" x 3/8" x 20-1/2"
43	Paraf. cob. int.	4	Ø 3/8" x 2-1/2"	21	Contator	1	L. 2" x 3/8" x 25"
42	Contator	4	L. 1/2" x 3/8" x 20-1/2"	20	Contator	2	L. 2" x 3/8" x 20-3/8"
41	Contator	1	L. 4" x 3/8" x 20-1/2"	19	Roller do motor	2	Aço 1010
40	Contator	2	L. 6" x 3/8" x 20"	18	Flange do motor	2	Ø 3"
39	Viga T ¹ (ext.)	2	C. 6" x 8" x 8-1/2"	17	Supporte	2	Chapa (A36) Ø 6"
38	Contator	2	L. 8-1/2" x 3/8" x 2"	16	Paraf. cantador	2	Aço perfilado
37	Roller motor	1	JEFFREY	15	Roller do cantador	2	Aço 1010
36	Contator	1	L. 2" x 3/8" x 7"	14	Flange do freio	2	Ø 3-1/2"
35	Viga T ¹ (int.)	2	C. 6" x 8" x 8-1/2"	13	Contator	20	L. 2-1/2" x 3/8" x 20-3/8"
34	Contator	2	L. 6" x 3/8" x 8"	12	Contator	10	L. 2-1/2" x 3/8" x 20-3/8"
33	Contator	1	L. 4" x 3/8" x 20-1/2"	11	Roller do motor	2	Ø 3-1/2"
32	Contator	2	L. 2-1/2" x 3/8" x 20-1/2"	10	Roller de carga	22	Chapa 1010 JEFFREY
31	Paraf. cob. ext.	42	Ø 1/2" x 2-1/2"	9	Contator	1	JEFFREY (tamanho 10")
30	Paraf. cob. int.	80	Ø 5/8" x 1-1/2"	8	Flange motor	4	Ø 3"
29	Arroto superior	80	Ø 5/8"	7	Paraf. cob. int.	4	Ø 1/2" x 2"
28	Paraf. motor	80	Ø 5/8"	6	Arroto superior	4	Ø 5/8"
27	Chapa de apoio	8	Aço 1010	5	Arroto superior	4	Ø 5/8"
26	Viga T ¹ (ext.)	1	C. 6" x 8" x 20"	4	Contator	8	L. 2-1/2" x 3/8" x 20-1/2"
25	Contator	1	L. 2" x 3/8" x 22"	3	Contator	2	L. 2" x 3/8" x 2"
24	Flange motor	1	JEFFREY	2	Paraf. cob. int.	80	Ø 5/8" x 1-1/2"
23	Flange motor	1	C. 6" x 8" x 20"	1	Viga T ¹ (int.)	1	C. 6" x 8" x 20"
22	Flange motor	1	JEFFREY	0			
21	Flange motor	1	JEFFREY	0			
20	Flange motor	1	JEFFREY	0			
19	Flange motor	1	JEFFREY	0			
18	Flange motor	1	JEFFREY	0			
17	Flange motor	1	JEFFREY	0			
16	Flange motor	1	JEFFREY	0			
15	Flange motor	1	JEFFREY	0			
14	Flange motor	1	JEFFREY	0			
13	Flange motor	1	JEFFREY	0			
12	Flange motor	1	JEFFREY	0			
11	Flange motor	1	JEFFREY	0			
10	Flange motor	1	JEFFREY	0			
9	Flange motor	1	JEFFREY	0			
8	Flange motor	1	JEFFREY	0			
7	Flange motor	1	JEFFREY	0			
6	Flange motor	1	JEFFREY	0			
5	Flange motor	1	JEFFREY	0			
4	Flange motor	1	JEFFREY	0			
3	Flange motor	1	JEFFREY	0			
2	Flange motor	1	JEFFREY	0			
1	Flange motor	1	JEFFREY	0			

TRANSPORTADOR DE CORREIA

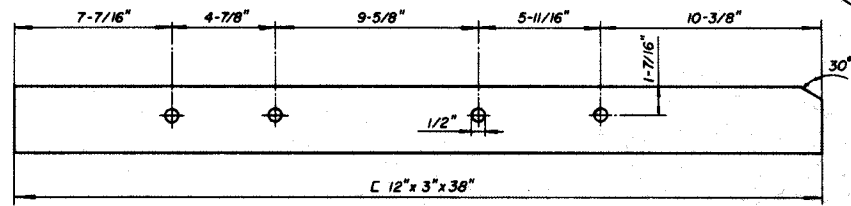

1 26

OBS. Peças 1 e 26 furações correspondentes

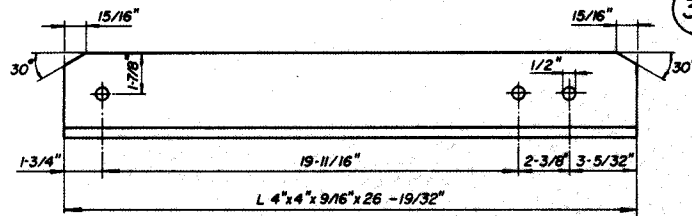
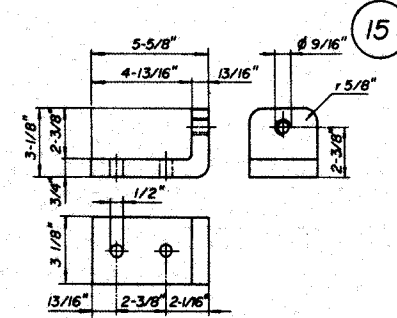
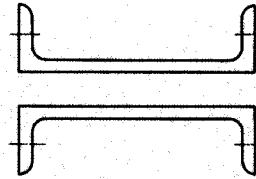

33 41

OBS. Peças 33 e 41 furações correspondentes

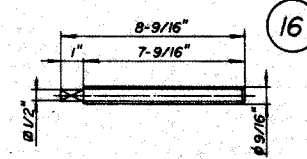
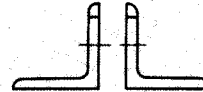

16

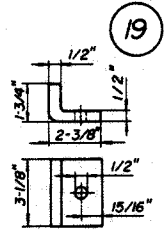

19

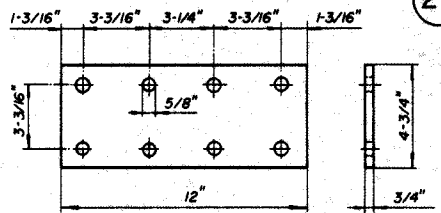

27

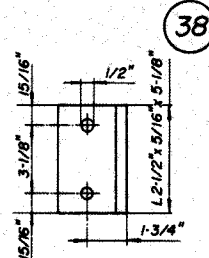

38

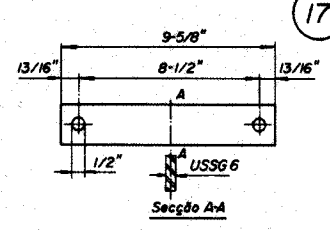

17

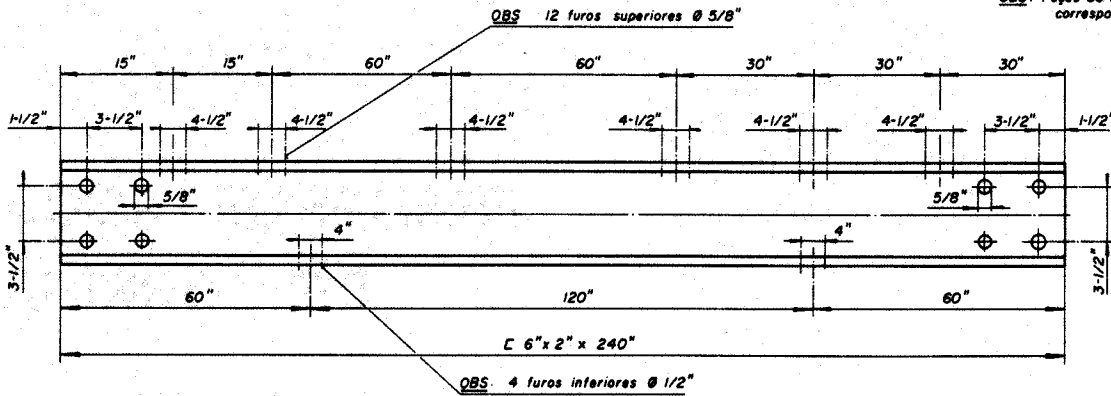
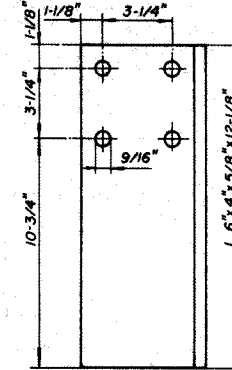

OBS. 12 furos superiores Ø 5/8"

OBS. Peças 35 e 39 furações correspondentes

OBS. 4 furos inferiores Ø 1/2"

35 39

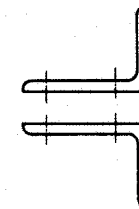
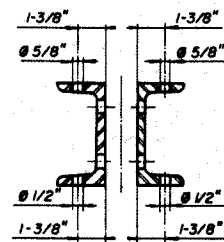

34 40

OBS. Peças 34 e 40 furações correspondentes

TRANSPORTADOR DE CANECA

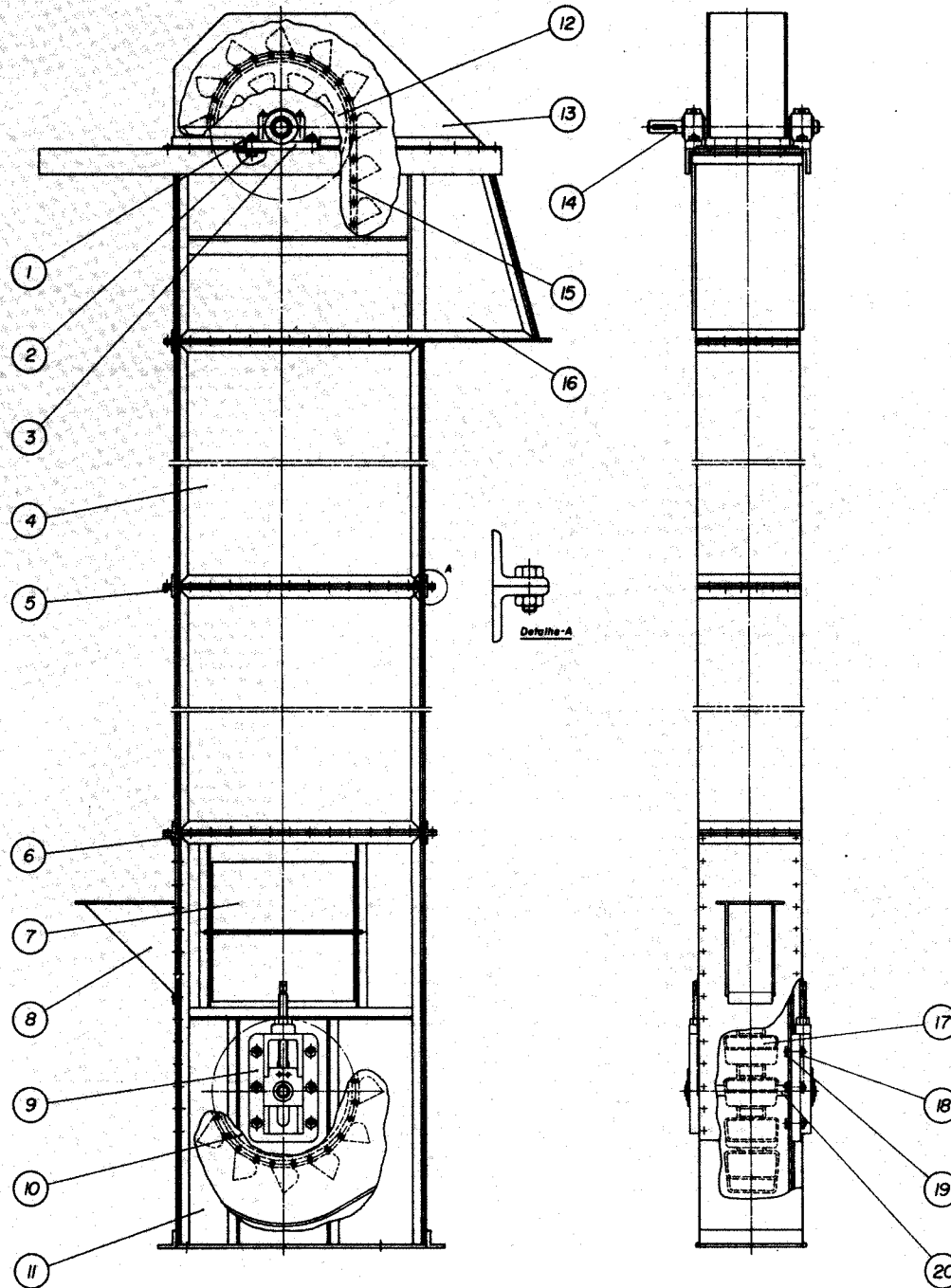

20	Eixo inferior	1	Vide lista, Nº 20	5	Eflicador	2	Vide lista, Nº 9
19	Paraf cob. sest.	6	Ø 1/2" x 50	8	Entrada de motor	1	Vide lista, Nº 8
18	Parco sextavado	6	Ø 1/2"	7	Tampa lateral	2	Vide lista, Nº 7
17	Caneca JEFFREY	56	Capac: 0,045 pe 1/2 caneca	6	Cont. de arêlo	1	L 2" x 2" x 1/4" x 460
16	Conjunto superior	1	Vide lista, Nº 16	5	Paraf., parco sest.	106	Ø 5/16" x 20
15	Corrente JEFFREY	1	Capac. p/ 0,045 pe 1/2 caneca	4	Conj. intermediário	2	Vide lista, Nº 4
14	Eixo superior	1	Vide lista, Nº 14	3	Motor SKF	2	P/ eixo Ø 60
13	Tampa do conj. sup.	1	Vide lista, Nº 13	2	Paraf cob. sest.	4	Ø 5/8" x 80
12	Arêlo p/ corrente	1	JEFFREY, eixo c/ Ø 70	1	Parco sextavado	4	Ø 5/8"
11	Conjunto inferior	1	Vide lista, Nº 11	Nº	DENOMINAÇÕES		MATERIAL E DIMENSÕES
10	Roda p/ corrente	1	JEFFREY, eixo c/ Ø 60				

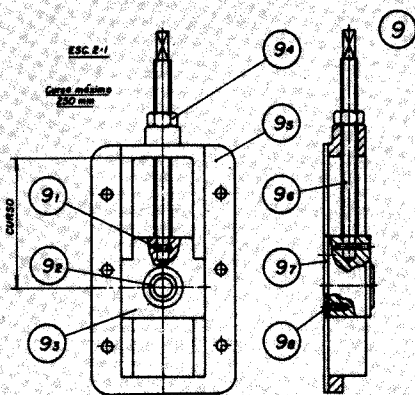
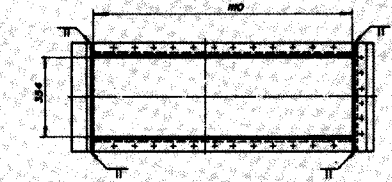
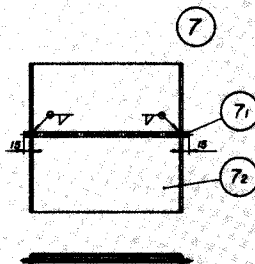
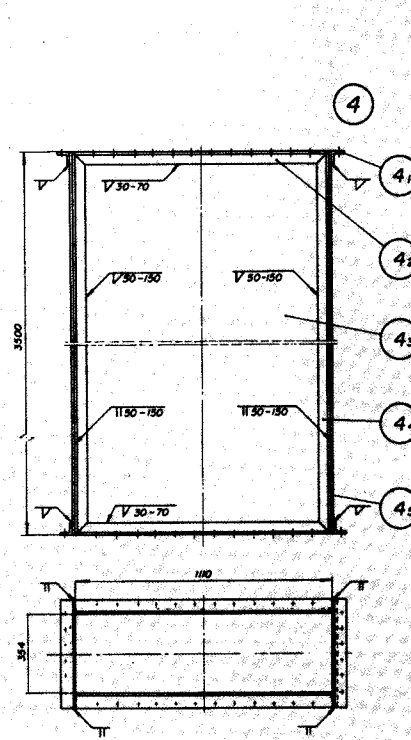
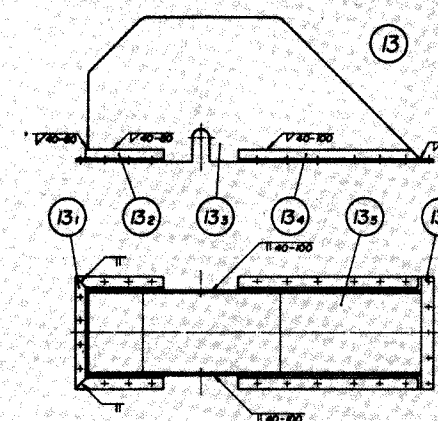
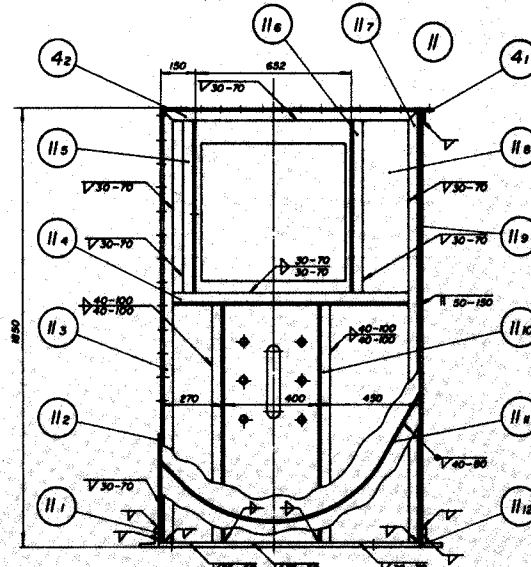
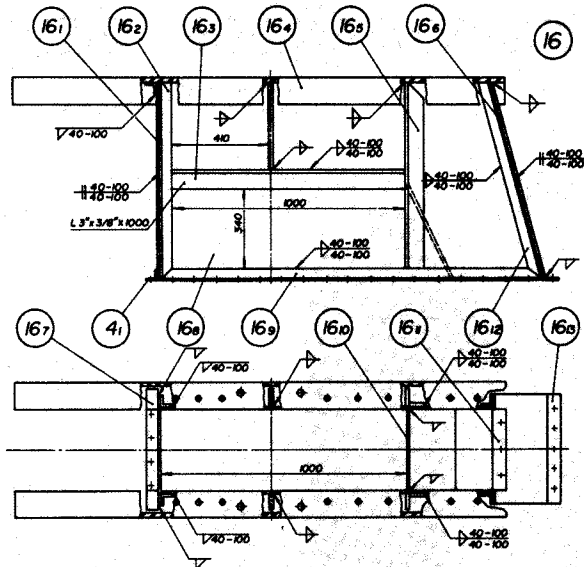

20a	Chaveiro	1	Marta 82
20b	Eixo inferior	1	Agp NB 1030
1a	Chapa de aço	1	Ø 3
1a1	Contornete	2	L 2" x 2" x 1/4" x 850
1a2	Chapa de aço	1	Ø 3
1a3	Chapa de aço	1	Ferro (U.S.S.) # 12
1a4	Contornete	2	L 2" x 2" x 1/4" x 850
1a5	Chapa de aço	2	Ferro (U.S.S.) # 12
1a6	Contornete	1	L 2" x 2" x 1/4" x 500
1a7	Chapa de aço	1	Ferro (U.S.S.) # 12 483-482
1a8	Contornete	2	L 3" x 3" x 3/8" x 785
1a9	Contornete	2	L 4" x 4" x 3/8" x 2100
1a10	Contornete	2	L 3" x 3" x 3/8" x 1000
1a11	Chapa de aço	2	Ferro (U.S.S.) # 12 328-480
1a12	Chaveiro	1	20x12x82
1a13	Chaveiro	1	Marta 82
1a14	Eixo superior	1	Agp NB 1030
1a15	Chapa de aço	1	Ø 3
1a16	Chapa de aço	1	Ferro (U.S.S.) # 12
1a17	Contornete	2	L 2" x 2" x 1/4" x 780
1a18	Chapa de aço	2	Ferro (U.S.S.) # 12
1a19	Contornete	2	L 2" x 2" x 1/4" x 380
1a20	Chapa de aço	1	L 2" x 2" x 1/4" x 480
1a21	Chapa de aço	2	Ø 1
1a22	Chapa de aço	1	Ferro (U.S.S.) # 12
1a23	Contornete	4	L 2" x 2" x 1/4" x 1000
1a24	Chapa de aço	1	Ferro (U.S.S.) # 12 483-480
1a25	Chapa de aço	2	Ferro (U.S.S.) # 12
1a26	Contornete	2	L 2" x 2" x 1/4" x 483
1a27	Contornete	2	L 2" x 2" x 1/4" x 783
1a28	Contornete	2	L 2" x 2" x 1/4" x 1000
1a29	Contornete	2	L 2" x 2" x 1/4" x 1213
1a30	Chapa de aço	1	Ferro (U.S.S.) # 12 480-443
1a31	Contornete	2	L 3" x 3" x 3/8" x 430
1a32	Paraf. cob. inox	2	Ø 1/4" x 30
1a33	Suprto	2	Agp NB 1020
1a34	Paraf. secutor	2	Agp NB 1030
1a35	Carga fixa	2	Ferro Anódico
1a36	Capota paraf	2	Botafumeiro Ø 7"
1a37	Capota metal	2	Ferro Anódico
1a38	Rebra	1	Botão 582 600
1a39	Paraf. de inox	4	Agp Inoxidável NB 030 Ø 1/4 x 27
1a40	Chapa de aço	1	Ferro (U.S.S.) # 12
1a41	Chapa de aço	1	Ferro (U.S.S.) # 12
1a42	Chapa de aço	1	Ferro (U.S.S.) # 13
1a43	Chapa de aço	1	Ferro (U.S.S.) # 13
1a44	Chapa de aço	2	Ferro (U.S.S.) # 13
1a45	Suprto	2	Agp Inoxidável, Ø 1/4" x 80
1a46	Chapa de aço	4	Ferro (U.S.S.) # 12 3500-440
1a47	Contornete	2	L 2" x 2" x 1/4" x 500
1a48	Chapa de aço	4	Ferro (U.S.S.) # 12 2500-110
1a49	Contornete	10	L 2" x 2" x 1/4" x 400
1a50	Cont. de vidro	10	L 2" x 2" x 1/4" x 460
1a51	DESCRIÇÕES	Quant	MATERIAL E DIMENSÕES

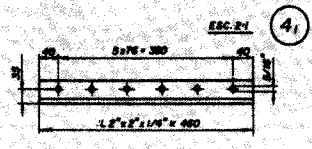

41

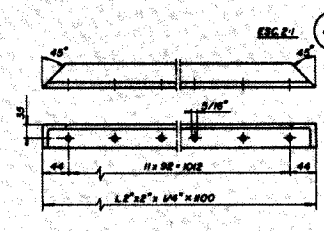

42

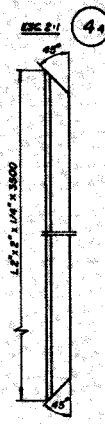

44

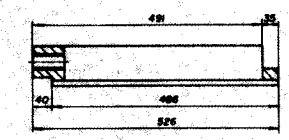

91

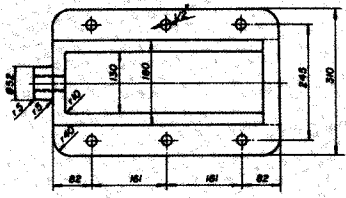

97

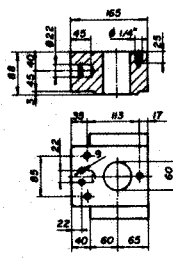
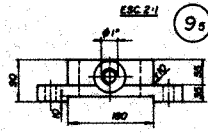

93

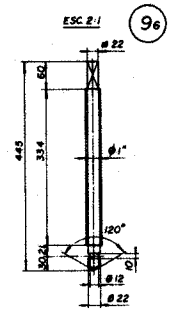

96

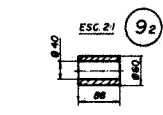

92

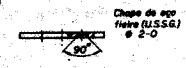

90

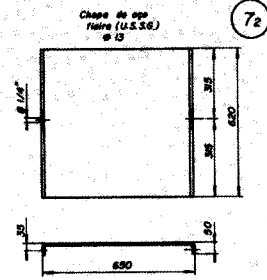

72

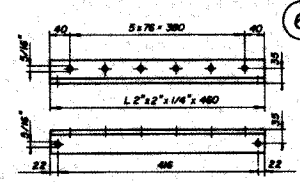

6

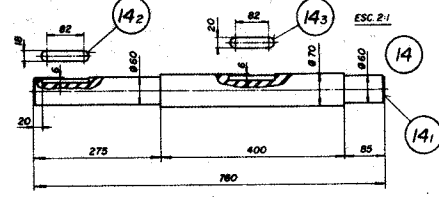

14

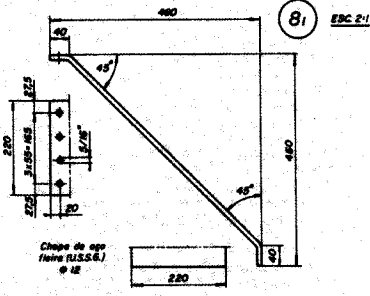

81

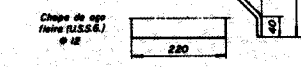

82

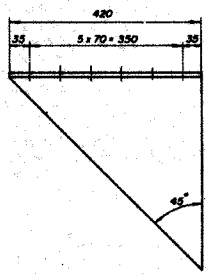

83

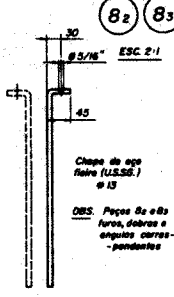

83

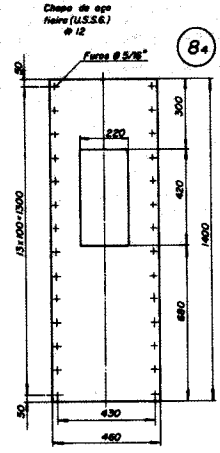

84

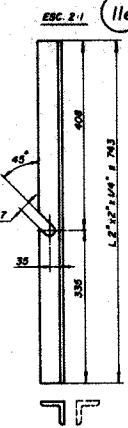

116

OBS: Peças de 10 quadras e 10 furos correspondentes

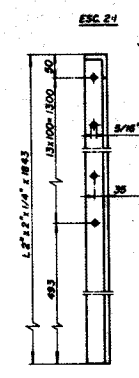

113

OBS: Peças opostas furo e centros correspondentes

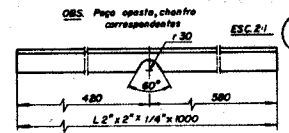

114

OBS: Peças opostas, centros correspondentes

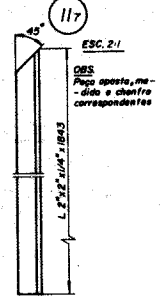

117

OBS: Peças opostas, m- dolo e centros correspondentes

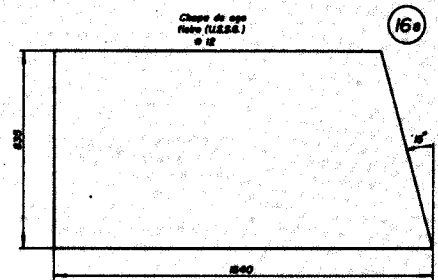
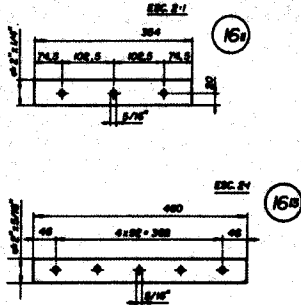
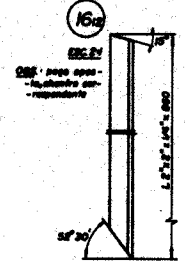
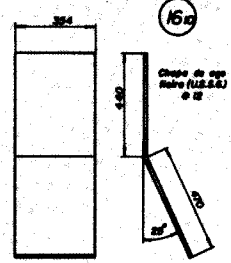
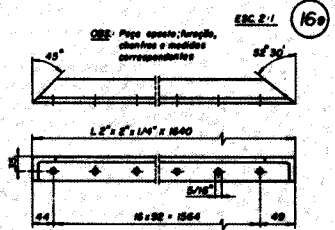
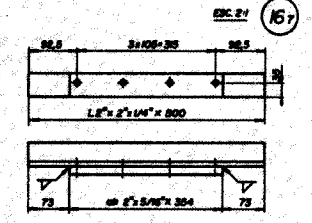
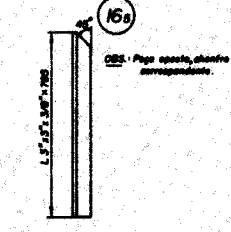
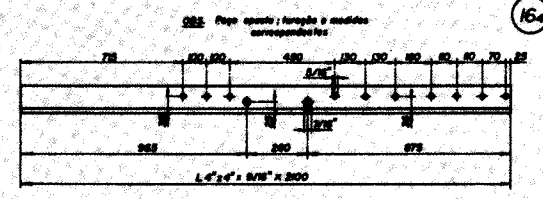
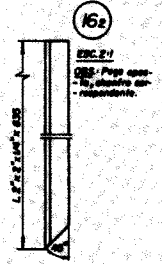
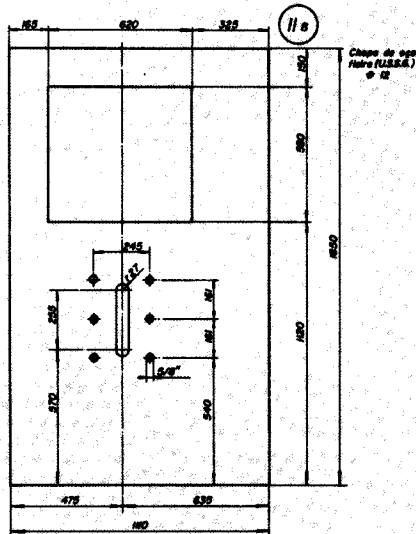
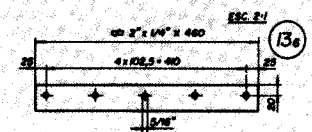
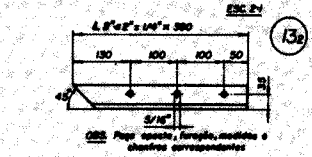
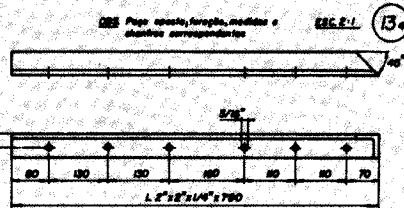
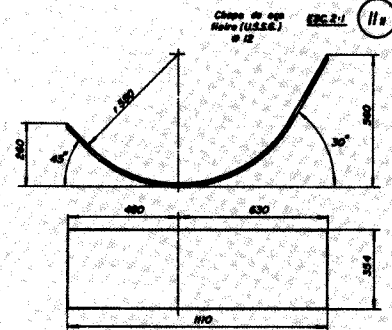
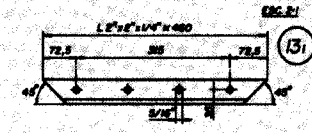
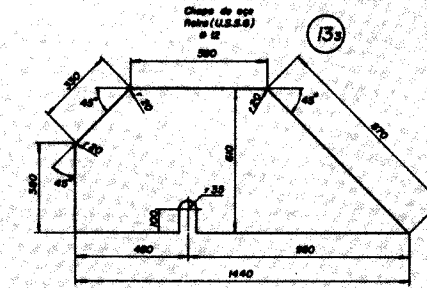
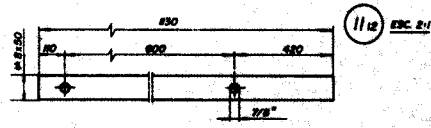
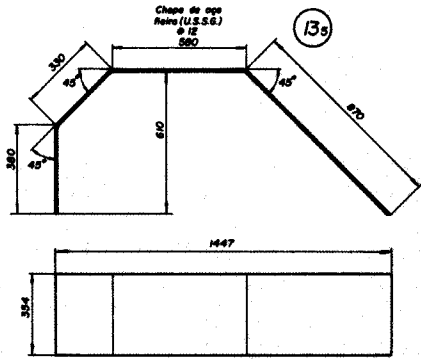

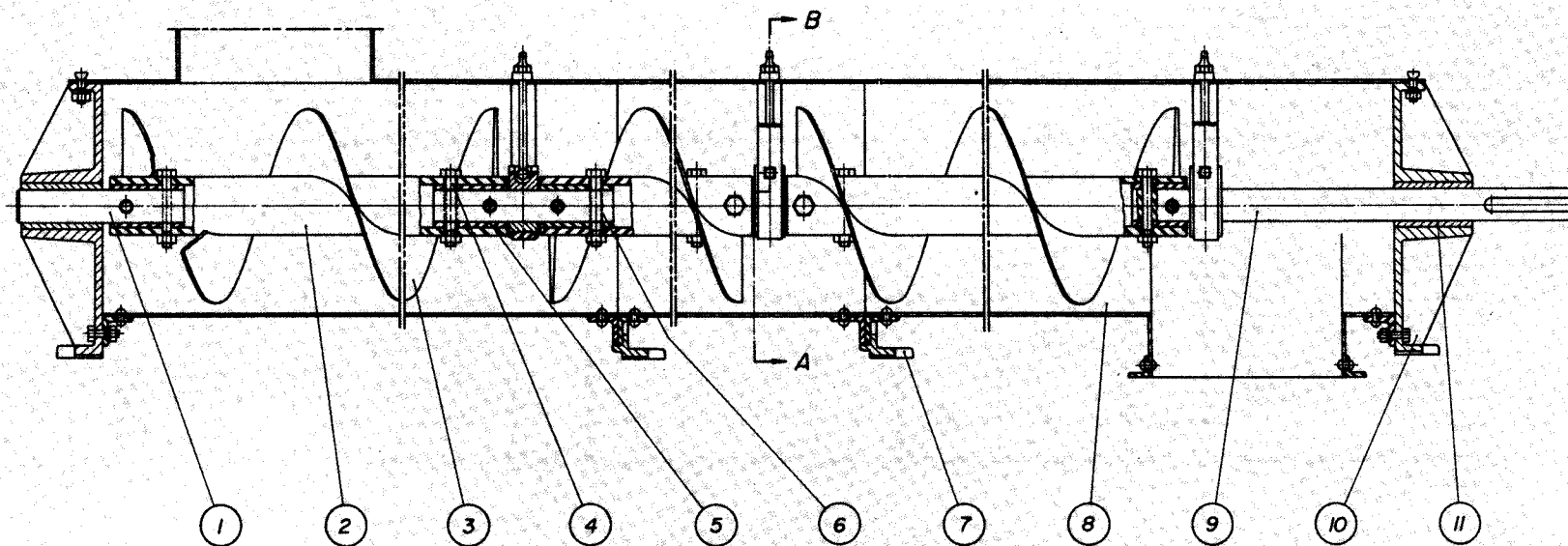

TRANSPORTADOR HELICOIDAL

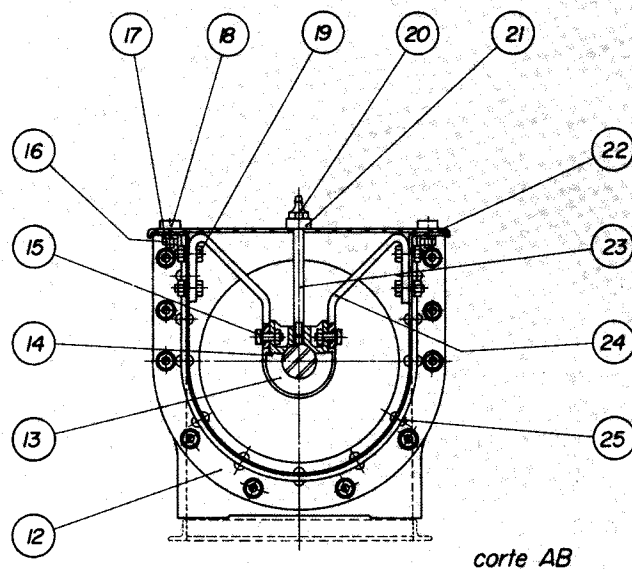

cut AB

25	Rebitas	66	Ø 5/16" x 9/16"	12	Flange	6	L 2" x 2" x 3/16"
24	Supporte do eixo	3	Aço NB 1030	11	Buchas	2	Bronze SAE 660
23	Cano de lubrif.	3	Aço Inoxidado NB 1020	10	Sup. das extrem.	2	Ferro fundido
22	Tampa	1	Aço NB 1020	9	Eixo motor	1	Aço Inoxidado NB 1030
21	Base da engrasadeira	3	Aço NB 1020	8	Gamela	1	Chapa de aço
20	Engrasadeira	5	Ø 3/8"	7	Supporte da gamela	2	Ferro fundido
19	Paraf. cob. sext.	12	Ø 9/16" x 2"	6	Eixo de acoplamento	1	Aço Inoxidado NB 1030
18	Paraf. especial	22	Ø 9/16" x 1-1/2"	5	Bucha	6	Aço NB 1020
17	Arruela de pressão	74	Ø 9/16"	4	Paraf. cob. sext.	14	Ø 9/16" x 4-1/4"
16	Parca soldada	76	Ø 9/16"	3	Hélice	3	Aço NB 1030
15	Paraf. cob. sext.	2	Ø 9/16" x 2"	2	Cubo da hélice	3	Aço Inoxidado NB 1030
14	Mancal superior	1	Bronze SAE 660	1	Eixo terminal	2	Aço Inoxidado NB 1030
13	Mancal inferior	1	Bronze SAE 660	Nº	DENOMINAÇÕES	Quant.	MATERIAL E DIMENSÕES

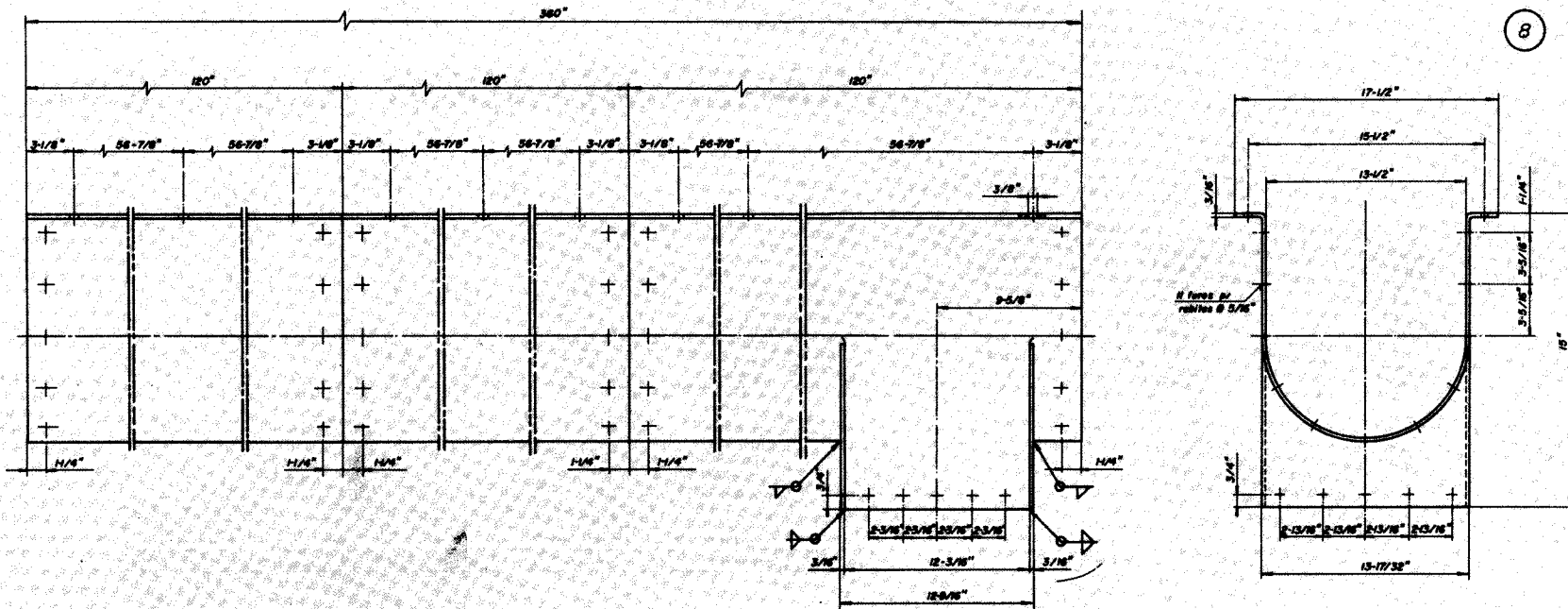
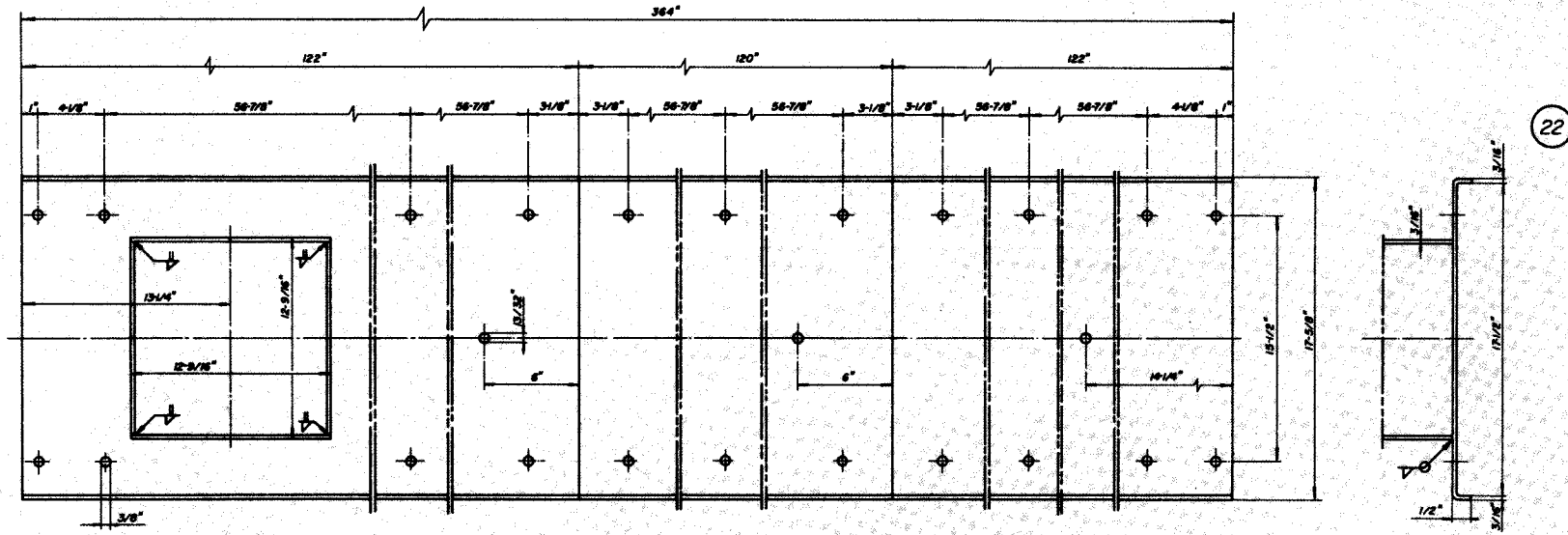

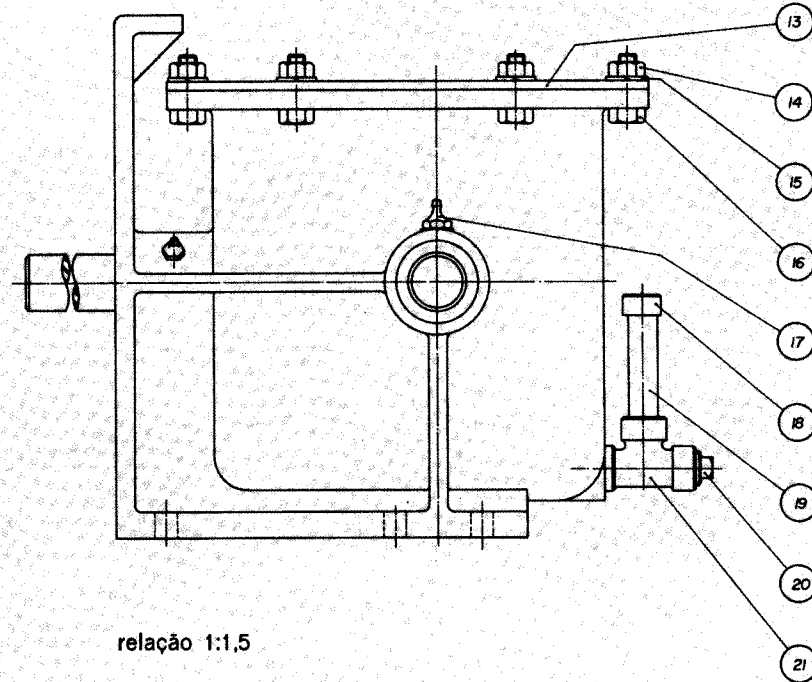
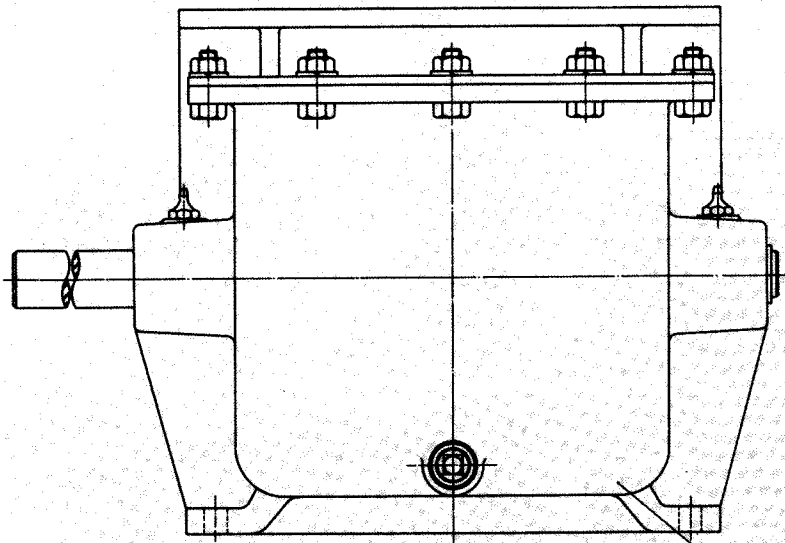

relação 1:1,5

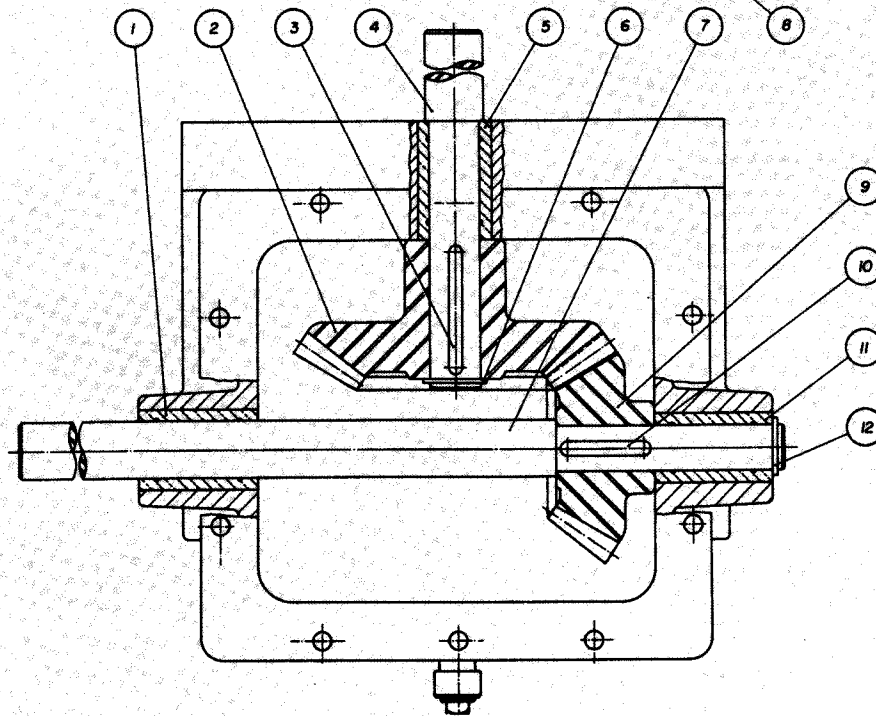

REDUTOR DO TRANSPORTADOR HELICOIDAL

21	Desocorja	1	Aço NB 1020	10	Chave paralela	1	15/32" x 5/16" x 3-23/32"
20	Buflô	1	Ø 1-3/32"	9	Parafuso	1	Aço NB 1030
19	Miel p/ Eixo	1	Aço NB 1020	8	Capa do redutor	1	Ferro fundido
18	Tempa de eixo	1	Aço NB 1020	7	Eixo de pinhão	1	Aço tratado NB 1030
17	Engrenadeira	3	Ø 1/2"	6	Anel oletico	1	Ø 1-3/4"
16	Paraf. eixo. sent.	10	Ø 9/16" x 30	5	Bucha	1	Bronce SAE 680
15	Arruela de pressão	10	Ø 9/16"	4	Eixo de eixo	1	Aço tratado NB 1030
14	Ferru serrilhada	10	Ø 9/16"	3	Chave paralela	1	5/32" x 5/16" x 4-13/32"
13	Tempa	1	Aço NB 1020 B&O	2	Cilindro	1	Aço NB 1030
12	Anel oletico	1	Ø 1- 5/16"	1	Bucha	1	Bronce SAE 680
11	Bucha	1	Bronce SAE 680	Nº	DENOMINAÇÕES	MATERIAL E DIMENSÕES	

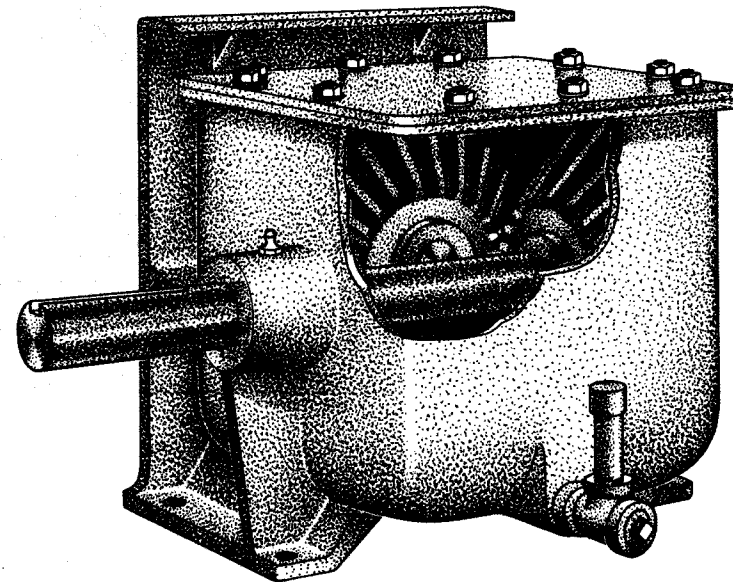
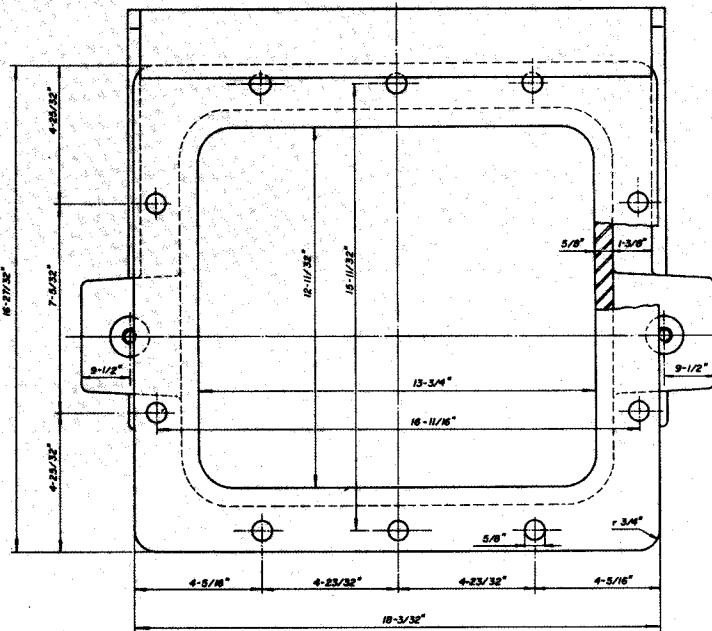
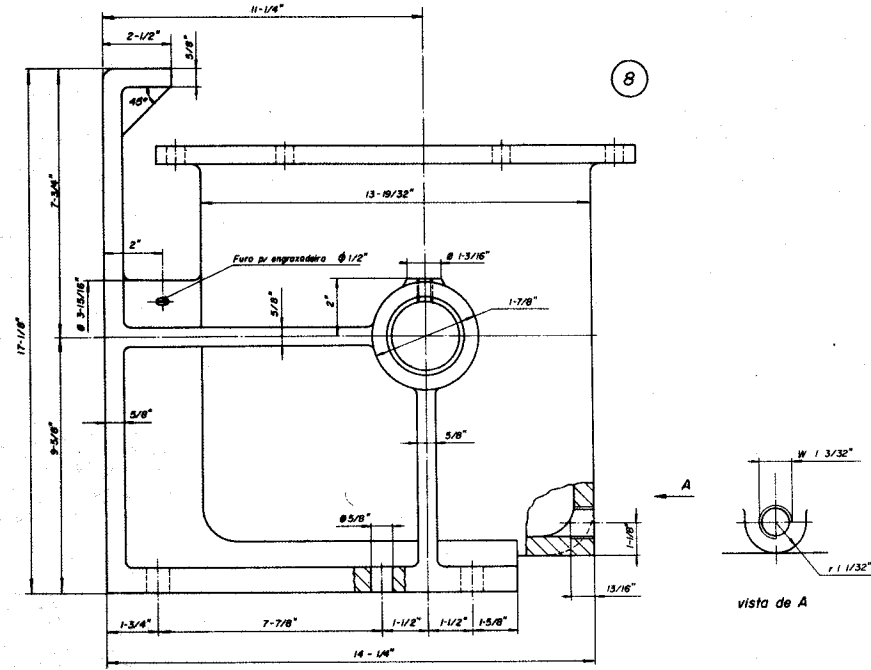
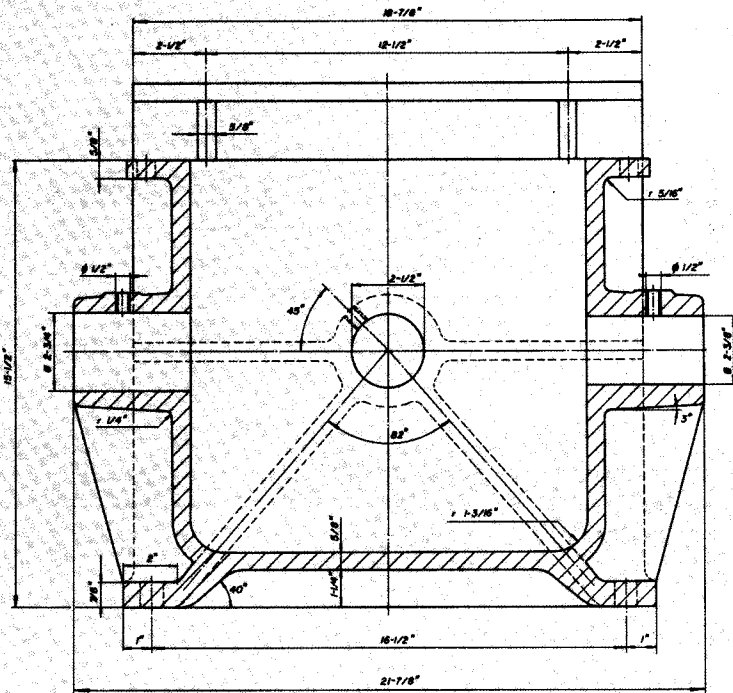

REDUTOR DE VELOCIDADE

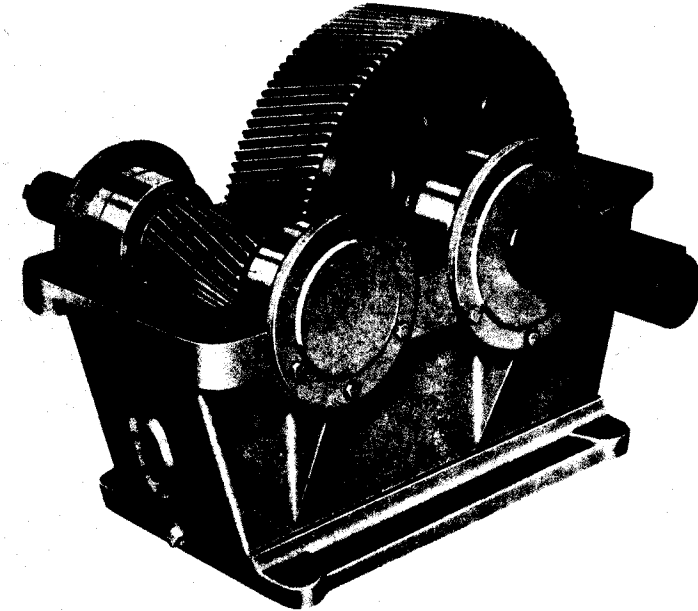
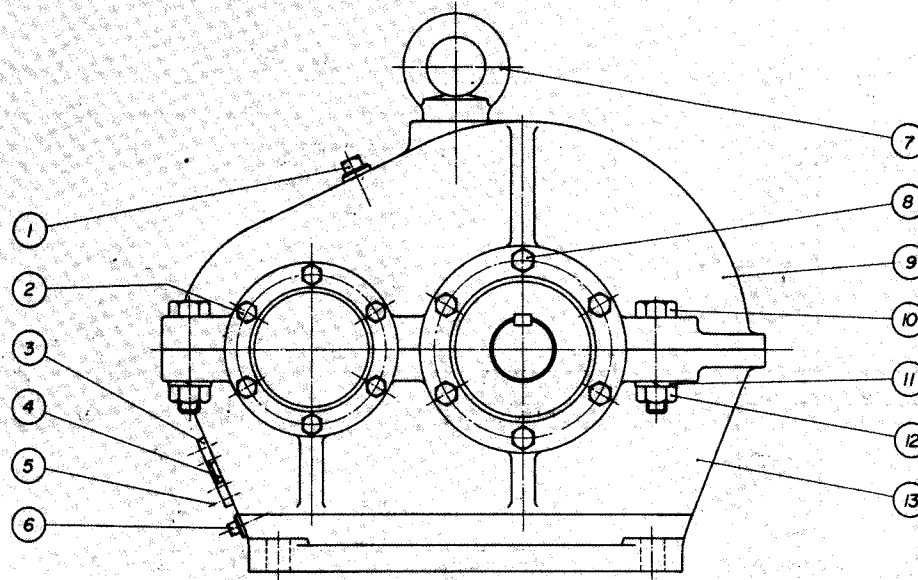

relação 1:3,8

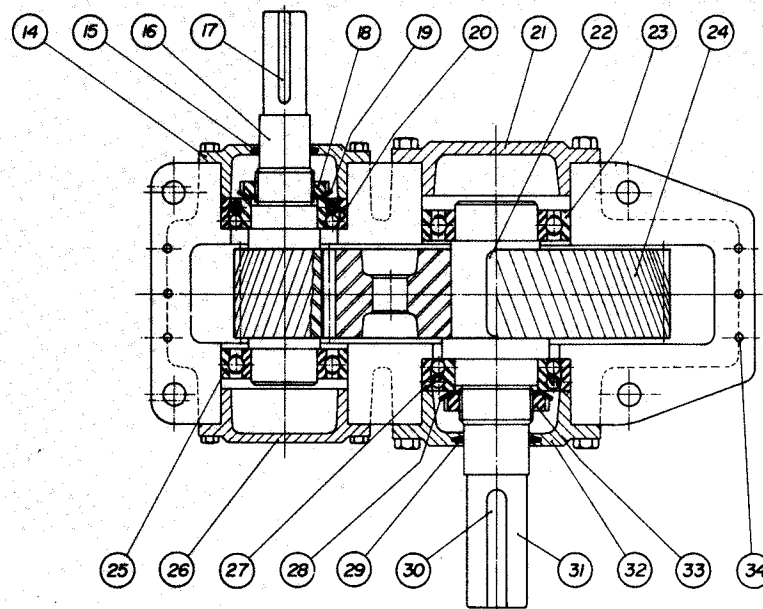

34	Pino guia	6	Ø1/4" x 15	17	Chaveta paralela	1	8 x 7 x 50	
33	Parca de fixação	1	SKF KM 10	16	Eixo pinhão	1	Aço NB 1040	
32	Tampa p/ rolam.	1	Ferro fundido	15	Anel de feltro	1	SKF FI 8	
31	Eixo da coroa	1	Aço NB 1030	14	Tampa p/ rolam.	1	Ferro fundido	
30	Chaveta paralela	1	12 x 8 x 70	13	Caixa do redutor	1	Ferro fundido	
29	Anel de feltro	1	SKF FI 10	12	Parca sextavada	4	Ø 9/16"	
28	Arruela de sep.	1	SKF MB 10	11	Arruela de pressão	4	Ø 9/16"	
27	Rolam. auto comp.	1	SKF 1211	10	Paraf. cob. sext.	4	Ø 9/16" x 64	
26	Tampa p/ rolam.	1	Ferro fundido	9	Tampa do redutor	1	Ferro fundido	
25	Rolam. fixo	1	SKF 6209	8	Paraf. cob. sext.	12	Ø 3/8" x 25	
24	Coroa	1	Aço NB 4524 AF	7	Paraf. de argola	1	Ø 3/4"	
23	Rolam. fixo	1	SKF 6211	6	Bujão	1	Ø 1/2" gds	
22	Chaveta paral. fixa	1	12 x 8 x 42	5	Paraf. cob. chata	6	Ø 1/4" x 6	
21	Tampa p/ rolam.	1	Ferro fundido	4	Visor p/ óleo	1	Acrílico incolor	
20	Rolam. auto comp.	1	SKF 1209	3	Moldura	1	Aço NB 1020	
19	Arruela de sep.	1	SKF MB 9	2	Paraf. cob. sext.	12	Ø 5/16" x 25	
18	Parca de fixação	1	SKF KM 9	1	Bujão	1	Ø 3/4" gds	
Nº DENOMINAÇÕES							Qtdº	MATERIAL E DIMENSÕES

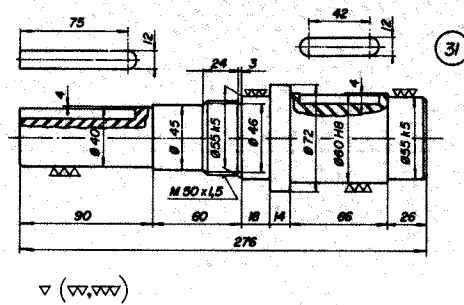
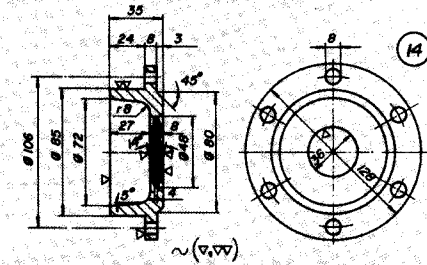
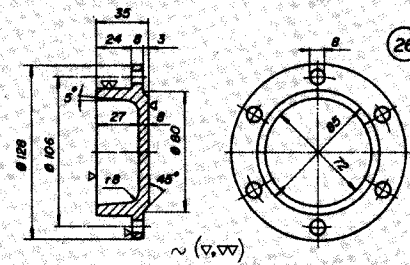
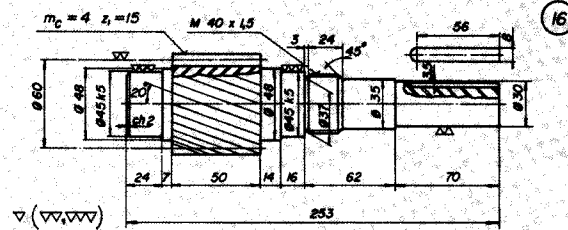
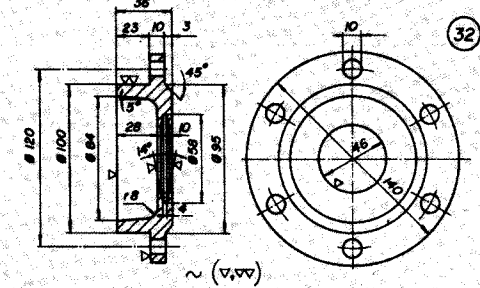
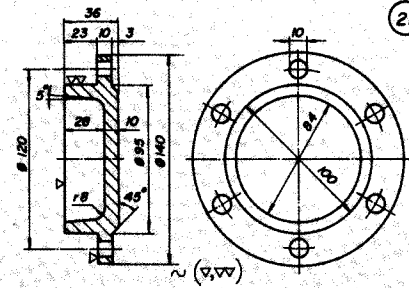
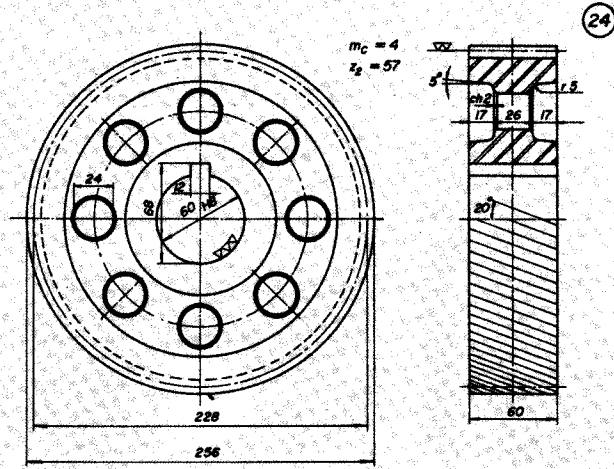

Colar na peça 3

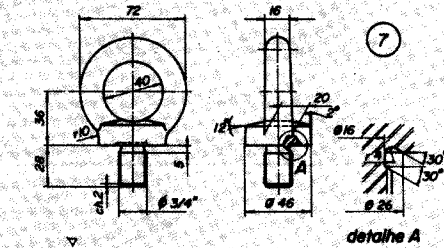
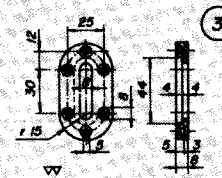
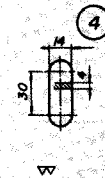

REDUTOR DE VELOCIDADE

relação 1:35,85

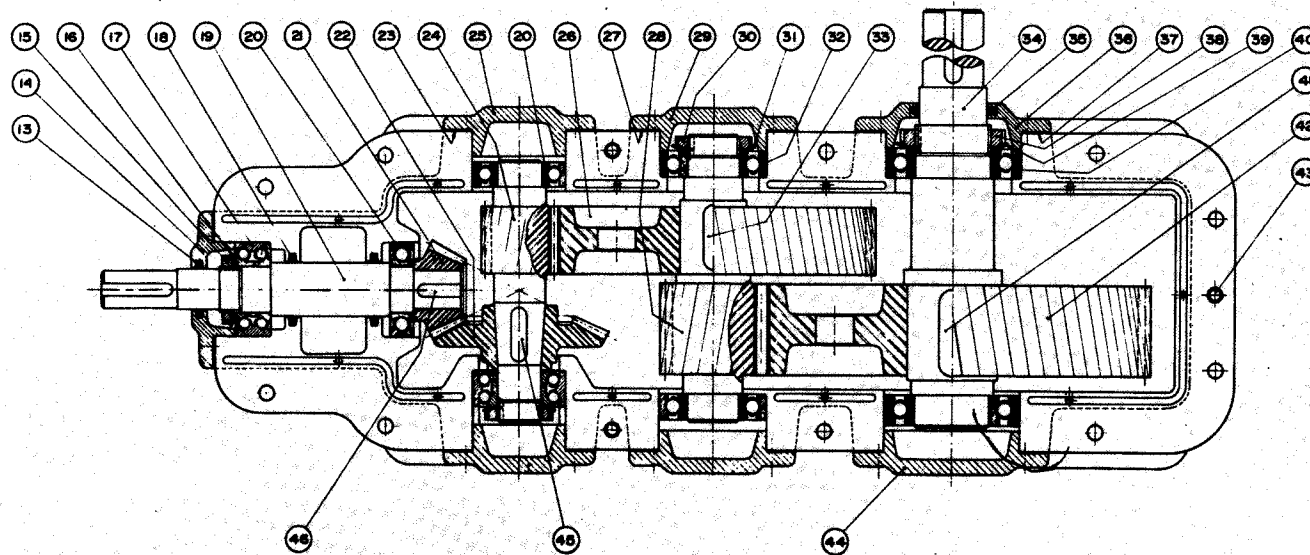
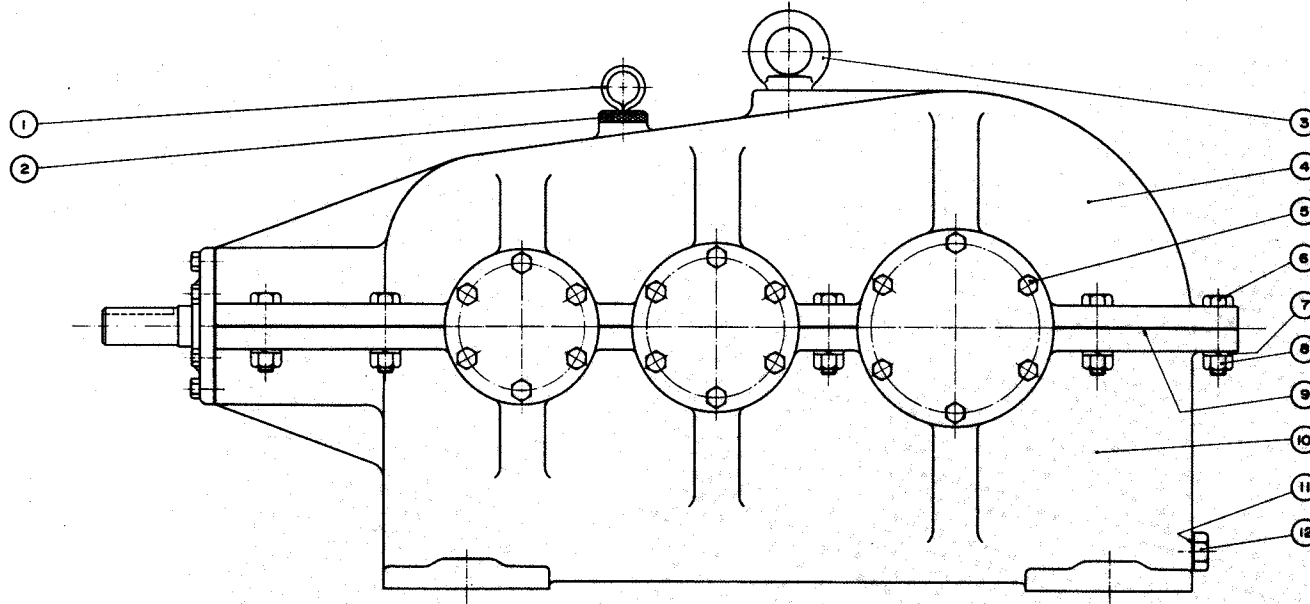

46	Chaveta	1	7x8x24
45	Chaveta	1	8x10x35
44	Tampa da caixa do rolam.	1	Ferro fundido
43	Pino de guia	3	Ø1/2" x 25
42	Coroa helicoidal	1	Aço NB 1030
41	Chaveta	1	11x14 x 5
40	Rolamento	2	SKF 6210
39	Arruela de segurança	1	SKF MB10
38	Parca de fixação	1	SKF KM 10
37	Guarnição	2	Papel Ø130
36	Tampa da caixa do rolam.	1	Ferro fundido
35	Anel de feltro	1	SKF FI 6
34	Eixo	1	Aço NB 1040
33	Chaveta	1	9 x 14 x 42
32	Rolamento	2	SKF 6207
31	Arruela de segurança	1	SKF MB 7
30	Parca de fixação	1	SKF KM 7
29	Tampa da caixa do rolam.	2	Ferro fundido
28	Eixo c/ pinhão helicoidal	1	Aço NB 1040
27	Guarnição	2	Papel Ø115
26	Coroa helicoidal	1	Aço NB 1030
25	Tampa da caixa do rolam.	2	Ferro fundido
24	Eixo c/ pinhão helicoidal	1	Aço NB 1040
23	Guarnição	3	Papel Ø105
22	Coroa cônica	1	Aço NB 1040
21	Pinhão cônico	1	Aço NB 1040
20	Rolamento	2	SKF 6206
19	Eixo	1	Aço NB 1040
18	Anel de feltro	2	SKF FI 7
17	Rolamento	2	SKF 3206
16	Arruela de segurança	2	SKF MB 6
15	Parca de fixação	2	SKF KM 6
14	Tampa da caixa do rolam.	1	Ferro fundido
13	Anel de feltro	1	SKF FI 6
12	Paraf. cob. sext. tampa da desc.	1	Ø1/2" x 12 x 1"
11	Guarnição	1	Papel Ø25
10	Caixa do redutor	1	Ferro fundido
9	Guarnição	1	Papel 680 x 210
8	Parca sextavada	10	Ø 3/8" x 16
7	Arruela de pressão	10	Ø 3/8"
6	Parafuso com cob. sext.	10	Ø 3/8" x 16 x 1 3/4"
5	Parafuso com cob. sext.	42	Ø 1/4" x 20 x 1/2"
4	Tampa do redutor	1	Ferro fundido
3	Gancho p/ suspensão	1	Aço fundido
2	Tampa da carga do óleo	1	Ferro redondo Ø32
1	Nível do óleo	1	Aço redondo Ø1/8" x 370
Nº	DENOMINAÇÕES		MATERIAL E DIMENSÕES

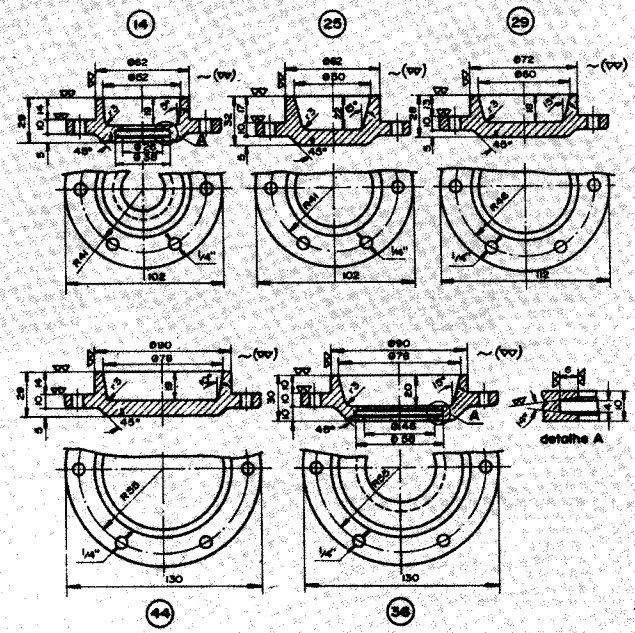
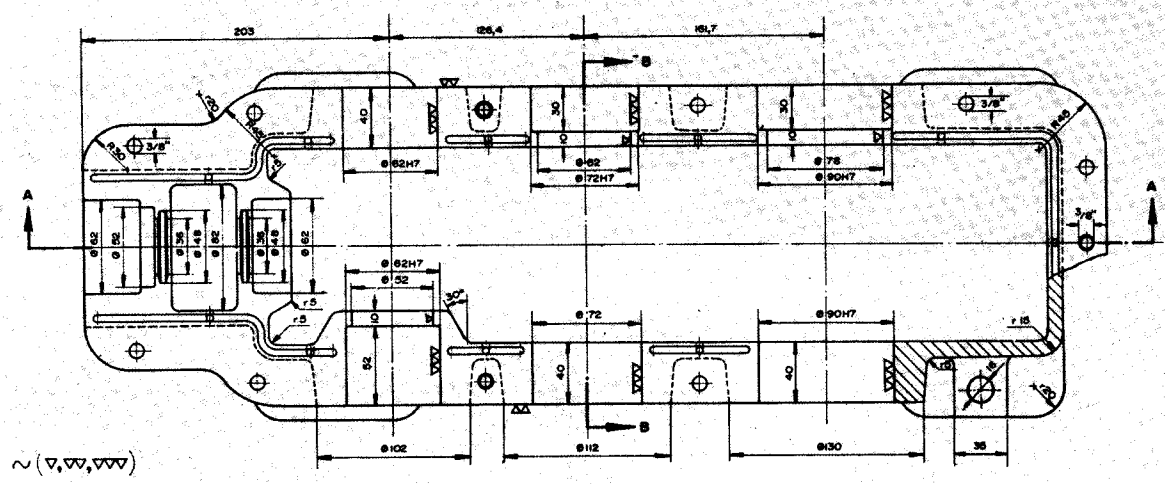
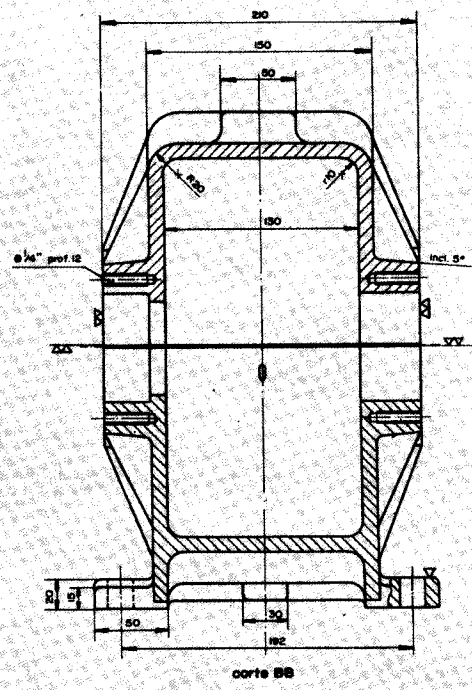
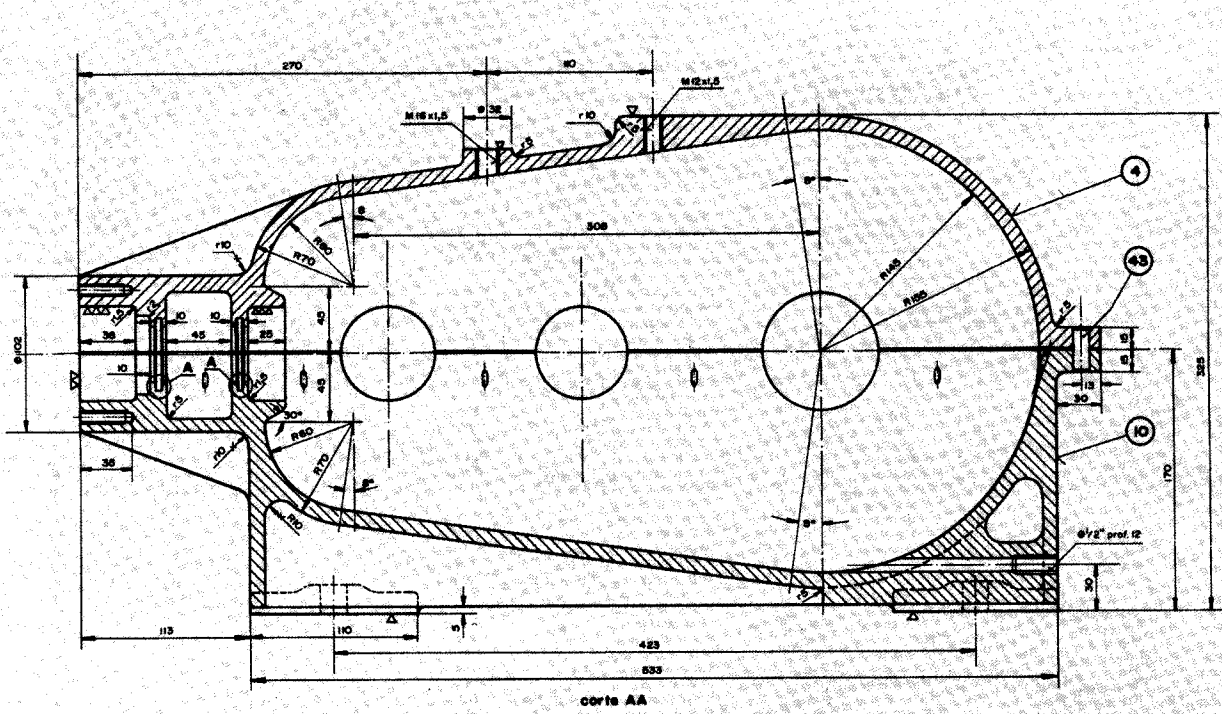

REDUTOR DE VELOCIDADE

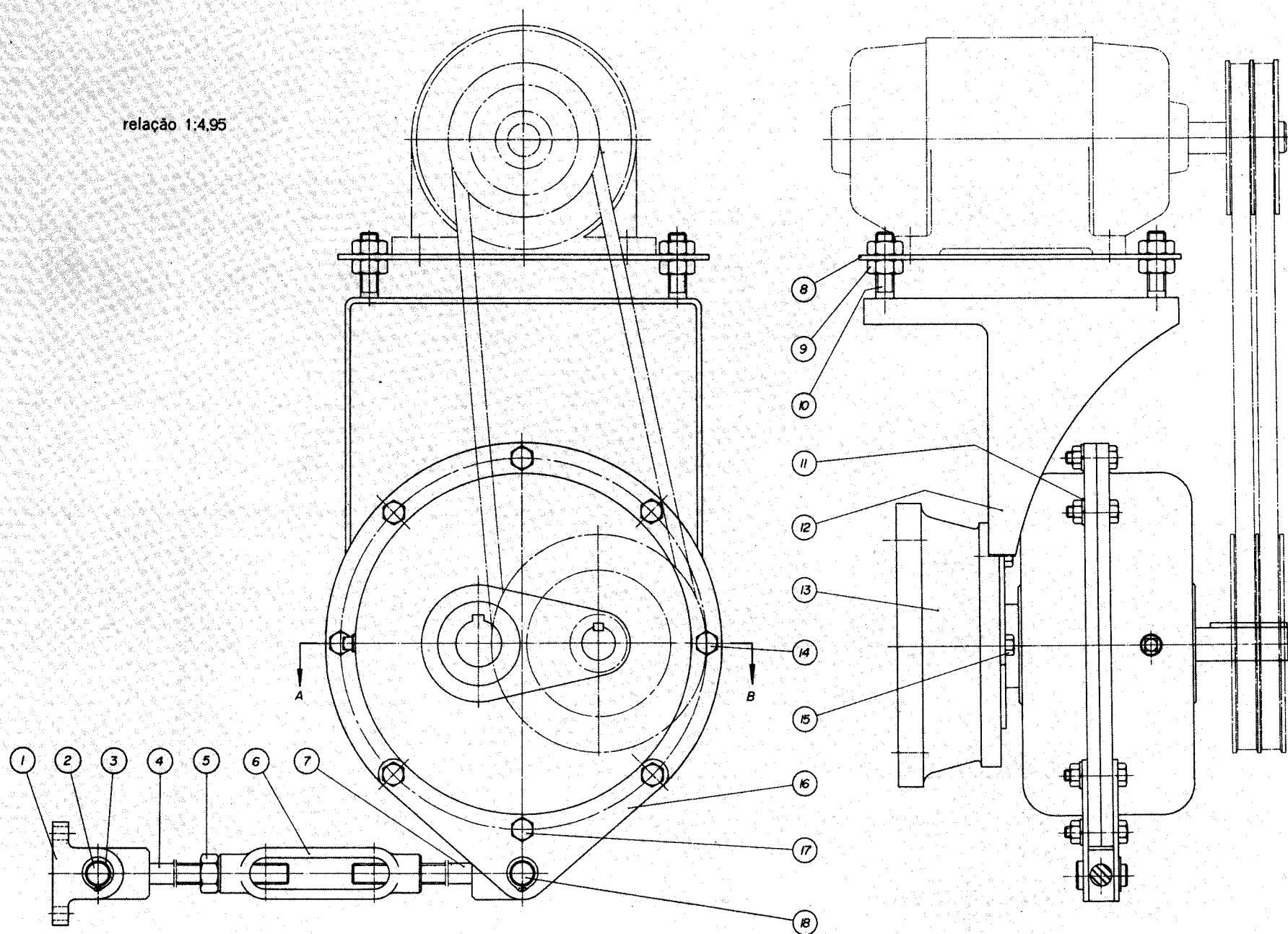

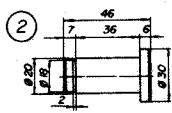
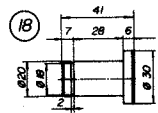
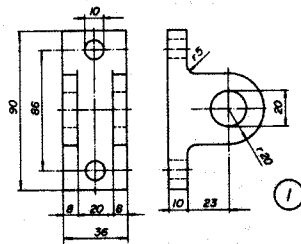
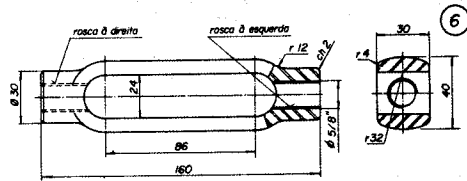

A peça ② é idêntica a peça ① com exceção da rosca que é à esquerda

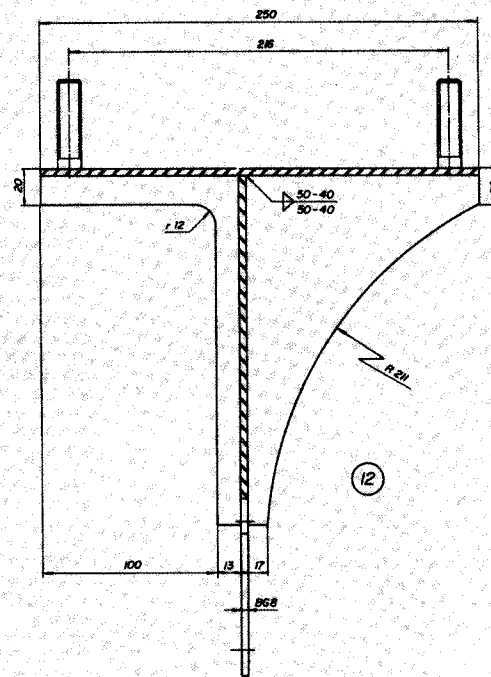
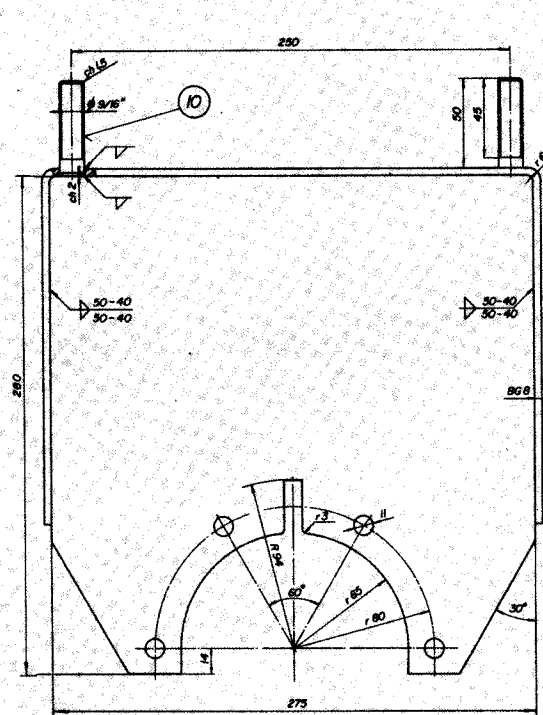
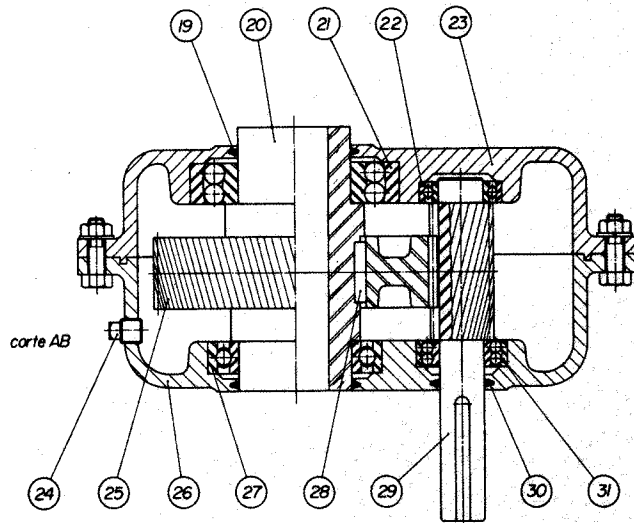
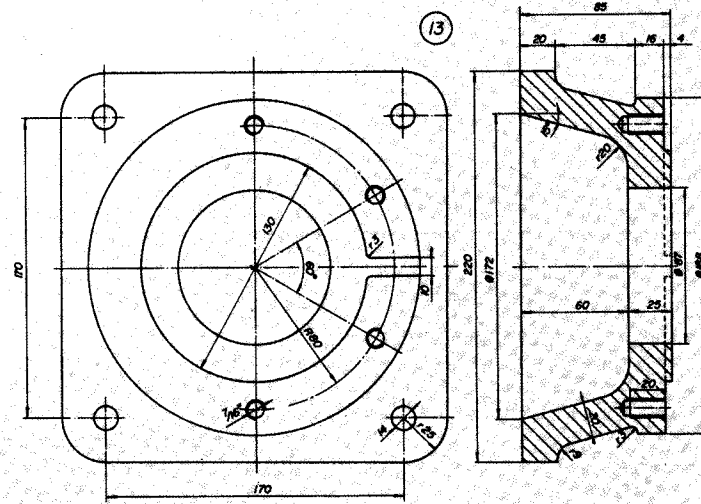
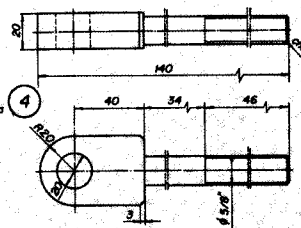

19	Reten. auto comp.	1	SNF 1805	22	Paraf. c/ab. aut.	4	Ø 3/16" x 1/8
20	Alav. de ferro	1	SNF 71 E	23	Paraf. c/ab. aut.	5	Ø 3/16" x 3/32
21	Eixo pinhão	1	Agp. NR 1030	24	Sup. do redutor	1	Ferro fundido
22	Chaveta	1	Ø 1/30 x 27	25	Sup. do motor	1	Agp. NR 1030 Ø 9/16"
23	Flange fixa	1	SNF 1030	26	Armaço do anelido	8	Ø 11
24	Carca. do redutor	1	Ferro fundido	27	Fio resaca	4	Agp. NR 1030 Ø 3/16"
25	Carde	1	Agp. NR 1030	28	Paraf. c/ab. aut.	6	Ø 3/16"
26	Mufla	1	Ø 1 1/2 x 1 1/2	29	Base do motor	1	Agp. NR 1030 Ø 1 1/2 x 1 1/2
27	Carca. do redutor	1	Ferro fundido	30	Parafusa	1	Agp. NR 1030 Ø 5/16" res.
28	Reten. fixa	1	SNF 1000	31	Estalador	1	Agp. ferro
29	Reten. auto comp.	1	SNF 1813	32	Paraf. livre	1	Ø 3/16"
30	Eixo do cardã	1	Agp. NR 1030	33	Parafusa	1	Agp. NR 1030 Ø 5/16" res.
31	Alav. de ferro	2	SNF 71 E	34	Alav. c/ab. aut.	2	Ø 1/32
32	Fio de resaca	1	Ø 1/32 x 1/8	35	Flan.	1	Ø 20 x 1/32
33	Paraf. c/ab. aut.	3	Ø 3/16" x 1/2	36	Flan.	1	Ø 20 x 1/32
34	Sup. do redutor	2	Agp. NR 1030 Ø 9/16"	37	Motor do esp.	1	Ferro fundido
				38	DECOMPOZIÇÃO		INFERIOR E OBRIGADO

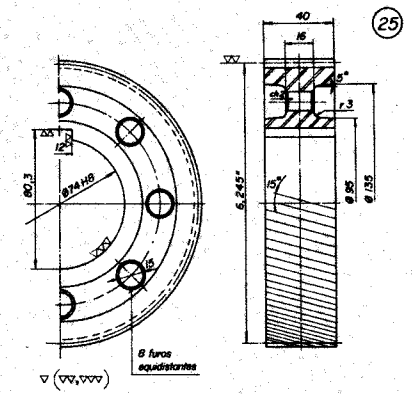
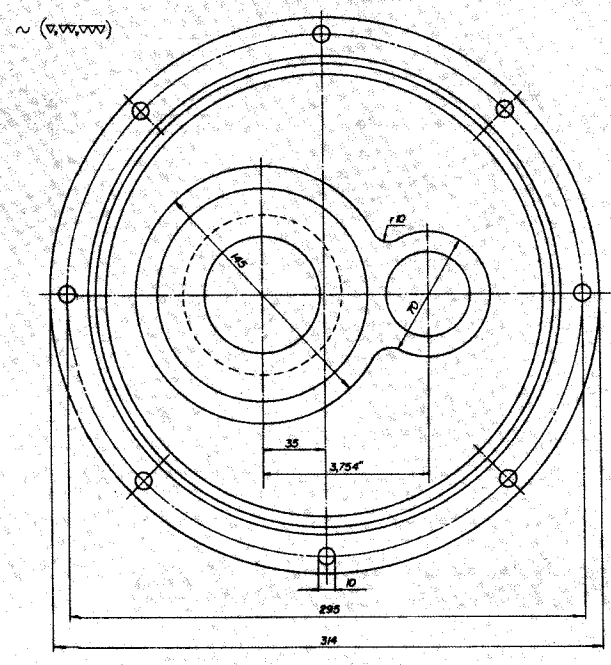
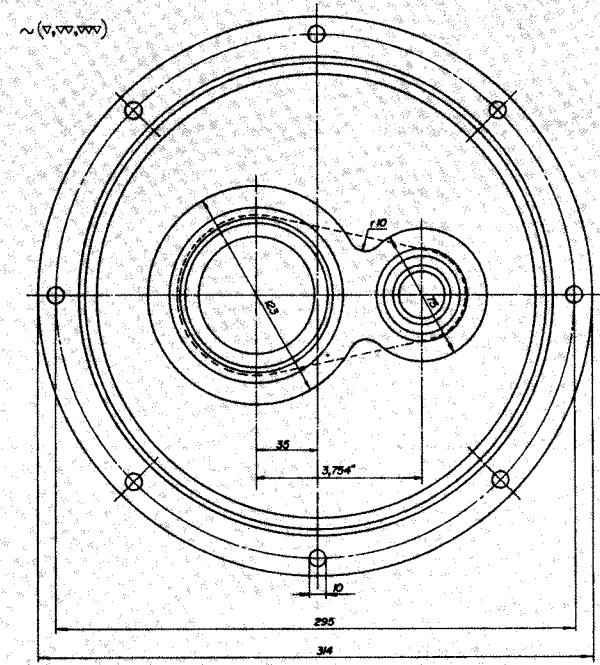
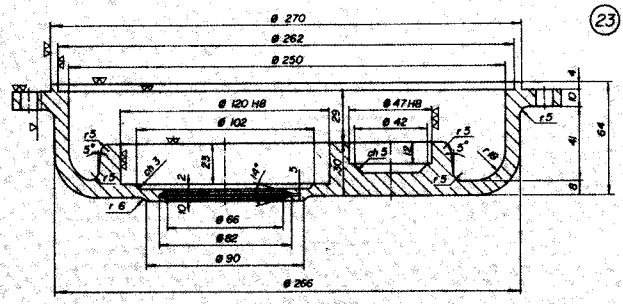
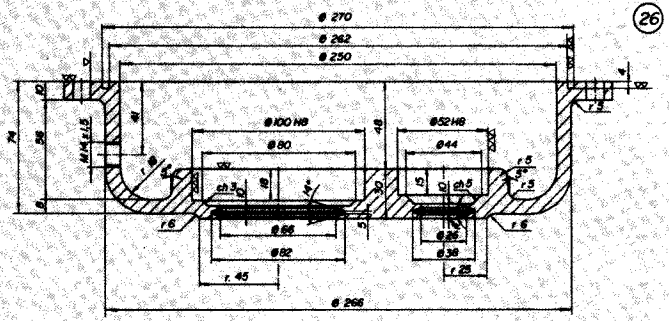

Diametral Pitch 13,45
Número de dentes 84

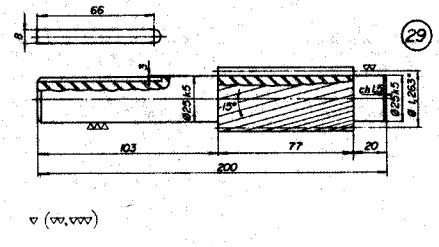
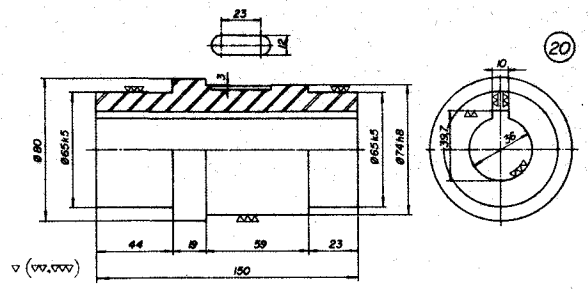
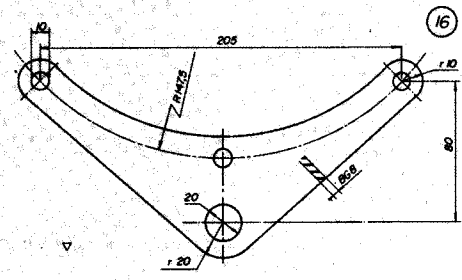

Diametral Pitch 13,45
Número de dentes 17

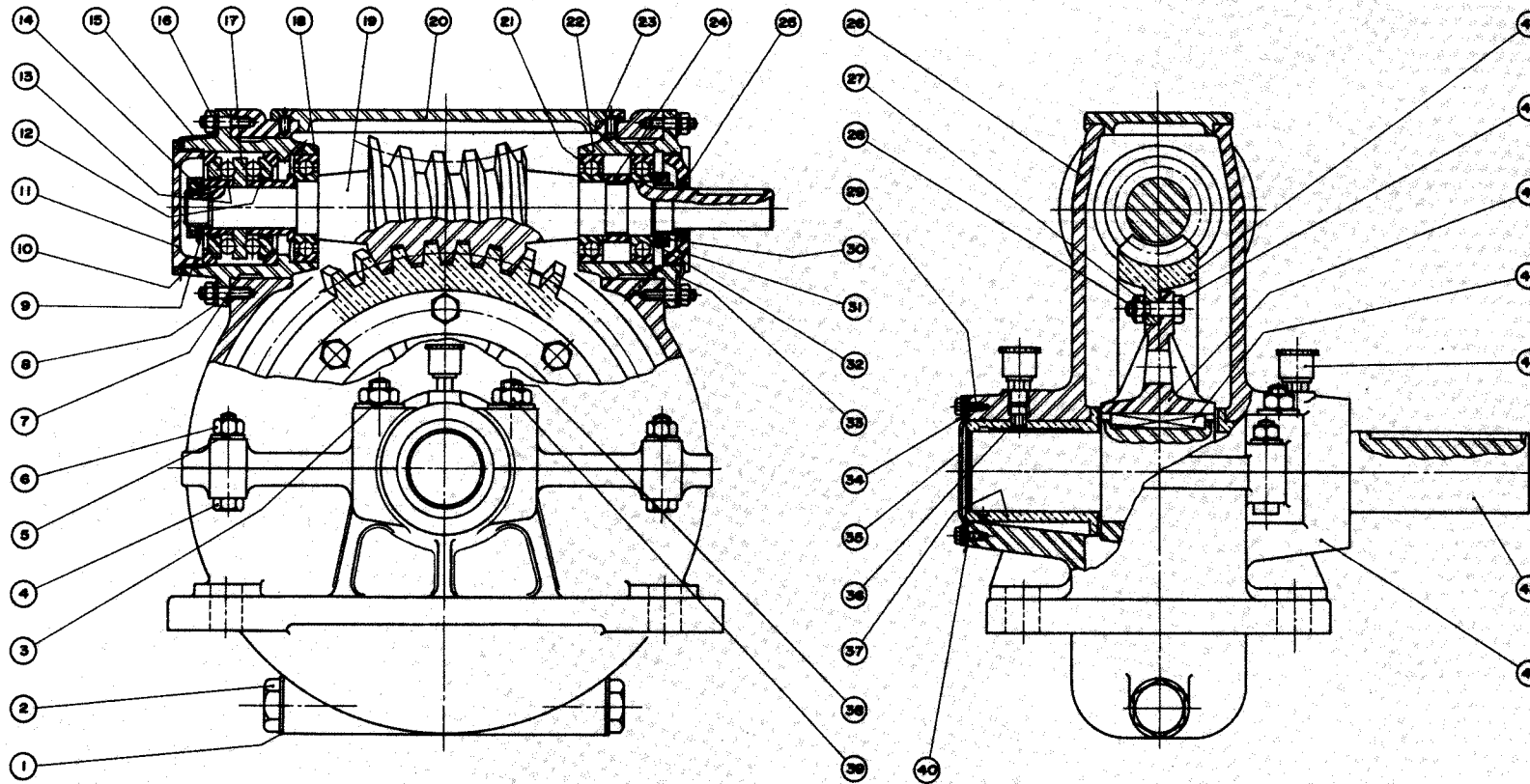

REDUTOR DE ROSCA SEM-FIM

relação 1:40

47	Corão	1	Bronze SAE 430-B	35	Tampa	1	Chapa	23	Paraf. cab. ohata	2	Ø5/16"x.35	11	Tampa	1	Aço NB 3525 AF
46	Paraf. cab. sext.	8	Ø3/8"x1/2"	34	Arruela de pressão	6	Ø7	22	Mancal	1	Aço NB 3525 AF	10	Guarnição	1	Fibra Ø89xØ100x2
45	Alma da corão	1	Aço NB 3525 AF	33	Arruela de segurança	1	CFF1 - CSN	21	Rotamento	3	SKF 6208	9	Arruela de segurança	1	SKF NB 6
44	Chaveia	1	18x11x70	32	Arruela de segurança	1	SKF NB 8	20	Tampa	1	Aço NB 3525 AF	8	Arruela de pressão	12	Ø9
43	Engraxadeira	2	Nº 2 Ø1/4"gs	31	Tampa	1	Aço NB 1010	19	Sem-fim	1	Aço NB 5140	7	Prisioneiro	12	Ø5/16"x.35
42	Eixo	1	Aço NB 5140	30	Parca de fixação	1	SKF KM 8	18	Mancal	1	Aço NB 3525 AF	6	Parca sextavada	4	Ø7/16"
41	Carcaça inferior	1	Aço NB 3525 AF	29	Paraf. cab. sext.	6	Ø1/4"x1/2"	17	Rotamento	1	SKF 54308 U	5	Arruela de pressão	4	Ø13
40	Guarnição	1	Fibra Ø110xØ75x2	28	Cupilha	8	Ø3/32"x1"	16	Parca sextavada	12	Ø5/16"	4	Paraf. cab. sext.	4	Ø7/16"x.23/8"
39	Parca sextavada	4	Ø5/8"	27	Parca castelo	8	Ø3/8"x16	15	Arruela de segurança	1	CFF1 - CSN	3	Arruela de pressão	4	Ø17
38	Prisioneiro	4	Ø5/8"x97	26	Carcaça sup.	1	Aço NB 3525 AF	14	Parca de fixação	1	SKF KM 6	2	Paraf. cab. sext.	2	M26x1,5x22
37	Bucha	2	Bronze SAE 680	25	Anel de feltro	1	SKF F17	13	Bucha	1	Aço NB 1010	1	Guarnição	2	Fibra Ø26xØ42x2
36	Pino	2	Aço NB 1010	24	Distanciador	1	Aço NB 1010	12	Bucha	1	Aço NB 1010	Nº	DENOMINAÇÕES		MATERIAL E DIMENSÕES

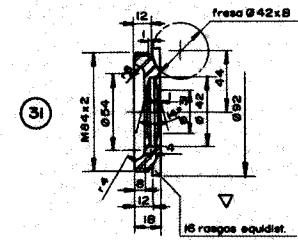
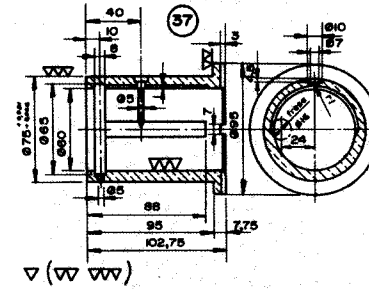
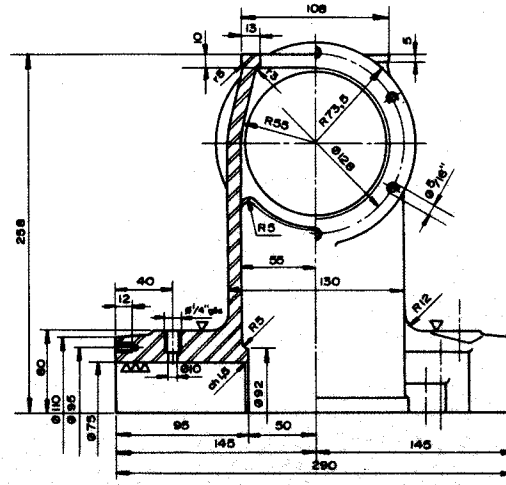
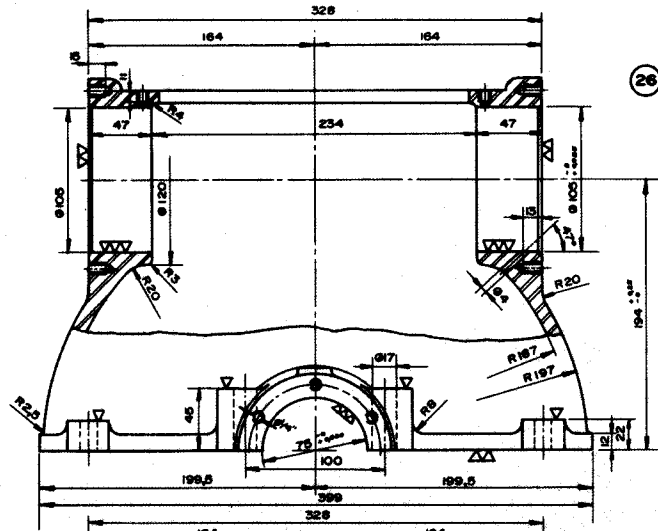

Secção AB

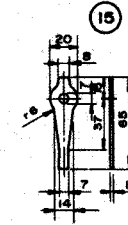
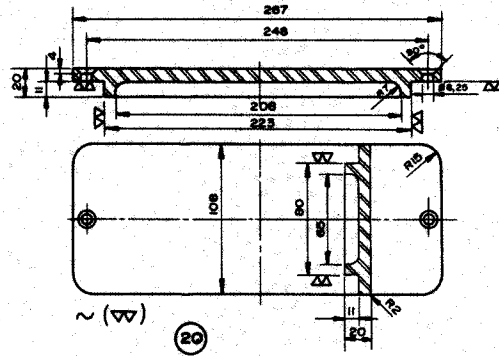
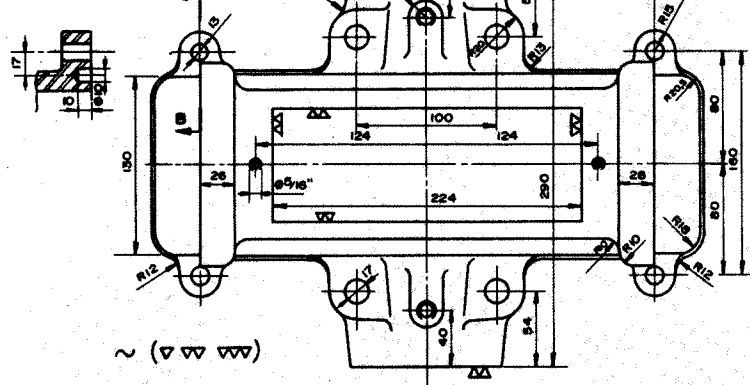

33

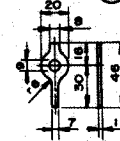

47

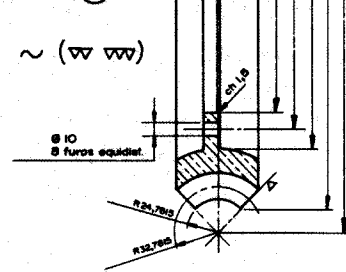

ROSCA SEM-FIM

módulo $m = 8$
 módulo aparente $m_a = 8,0608$
 diâmetro interno $d_i = 46,991$
 diâmetro primitivo $d_p = 65,563$
 diâmetro externo $d_e = 81,563$
 incl. do dente $\beta = 7^\circ$
 âng. de pressão $\theta = 15^\circ$
 dist. entre eixos $I = 193,9975$
 espessura do dente $s_a = 12,5632$



Secção BB

COROA

número de dentes $z = 40$
 módulo $m = 8$
 módulo aparente $m_a = 8,0608$
 diâmetro interno $d_i = 313,096$
 diâmetro primitivo $d_p = 322,432$
 diâmetro externo $d_e = 338,432$
 incl. do dente $\beta = 7^\circ$
 âng. de pressão $\theta = 15^\circ$
 I = 193,9975
 esp. do dente $s_a = 12,5632$

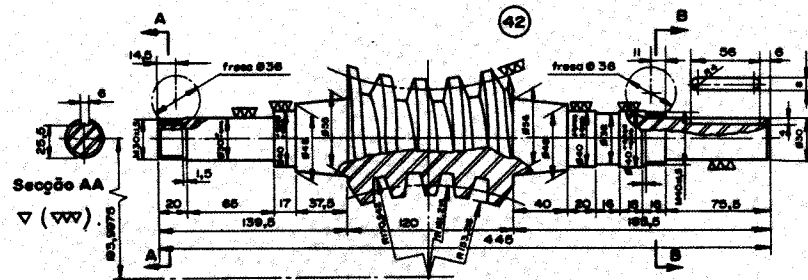

Secção AA

Secção AA

CAIXA DE DIREÇÃO

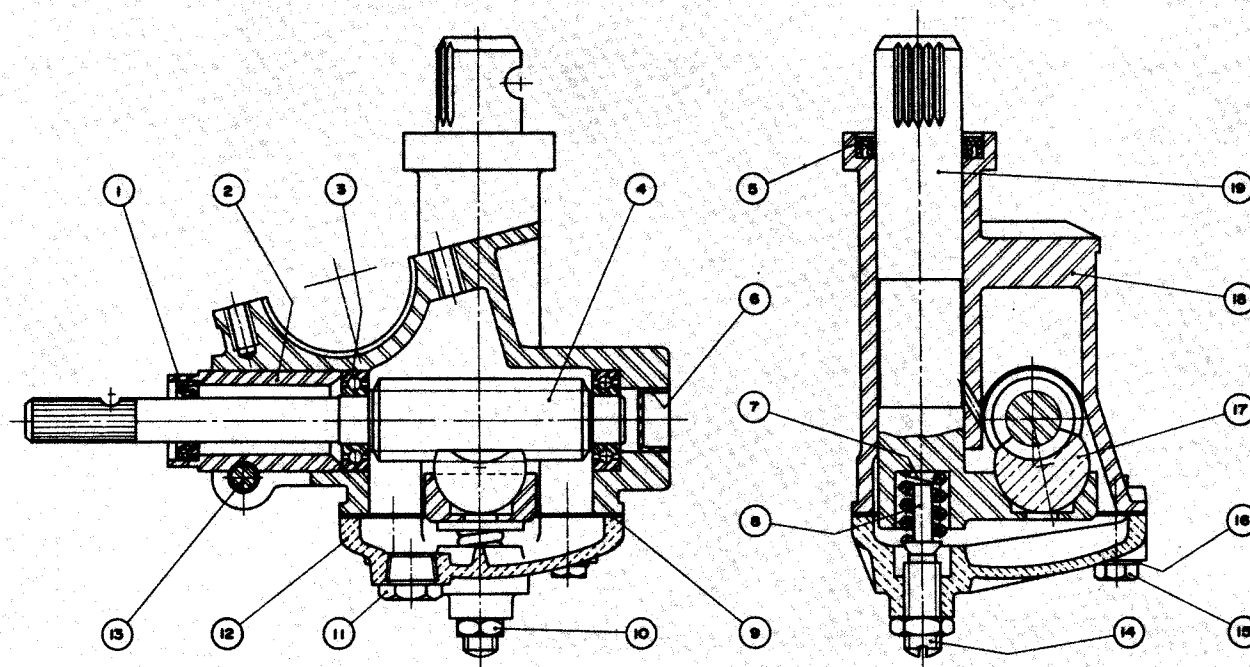

19	Eixo avanço	1	Aço NB 6020 AF	9	Guarnição	1	Papel
18	Carcapa	1	Aço NB 3525 AF	8	Pino	1	Aço NB 1030
17	Seguidor	1	Bronze SAE 430-E	7	Mola	1	Aço SAE 9250
16	Arruela	4	Ø 6,5	6	Tampa	1	Aço NB 1010 USSG Ø 14
15	Paraf. cob. sext.	4	M 6 x 28	5	Retentor	1	Ø 40 x Ø 27 x 7
14	Paraf. prisioneiro	1	M 12 x 32	4	Parafuso	1	Aço NB 5140
13	Paraf., porca e chap.	1	M 8 x 50	3	Rolamento	2	SKF 6002
12	Tampo	1	Liga Zamac	2	Encosto	1	Aço NB 1020
11	Bujão	1	Ø 5/8" gds	1	Retentor	1	Ø 27 x Ø 14 x 7
10	Porca sextavada	1	M 12	Nº	DENOMINAÇÕES		MATERIAL E DIMENSÕES

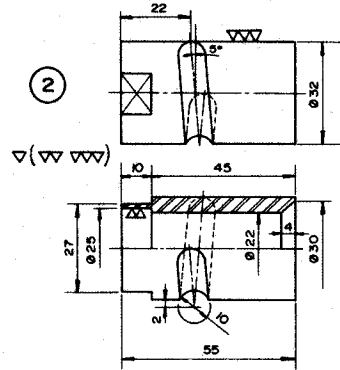
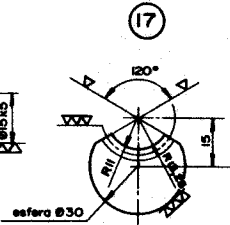
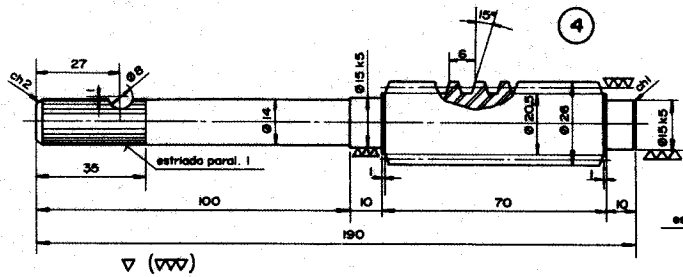
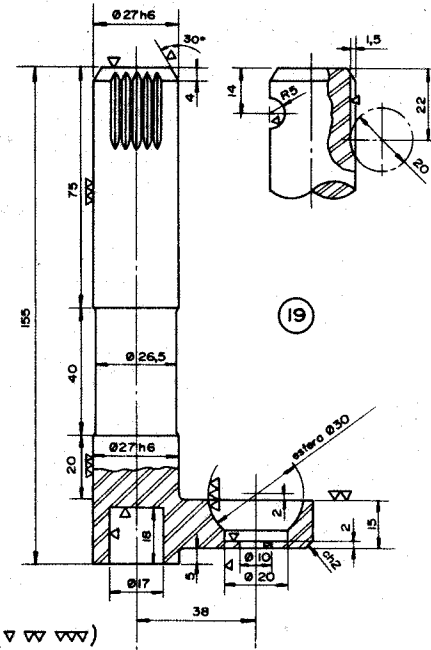
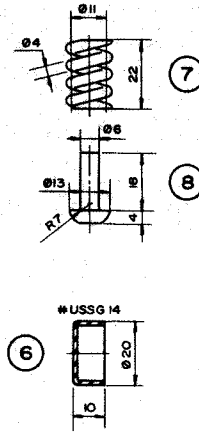
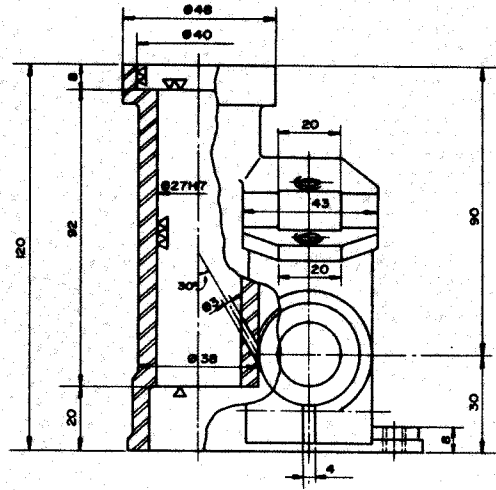
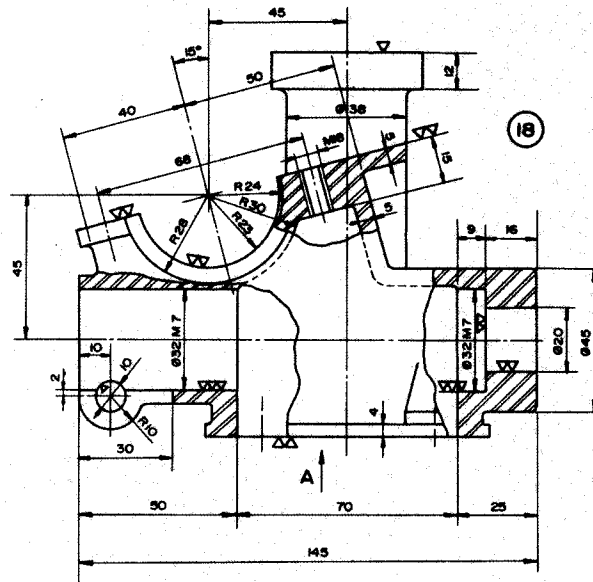
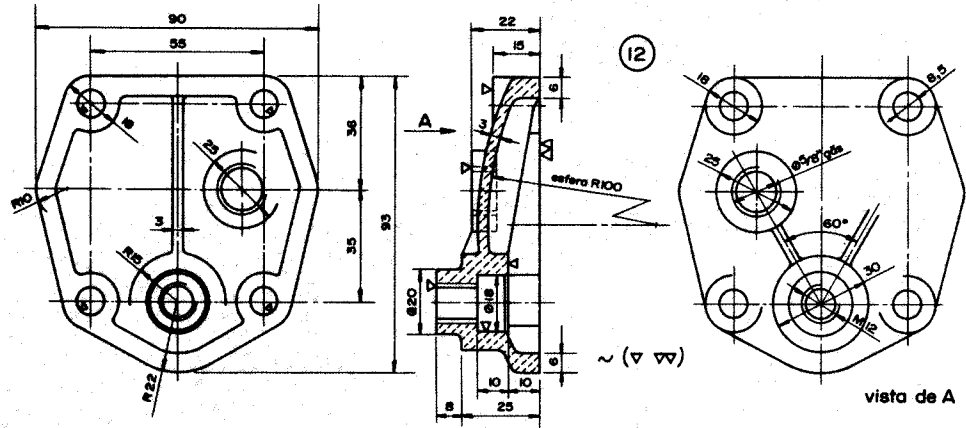
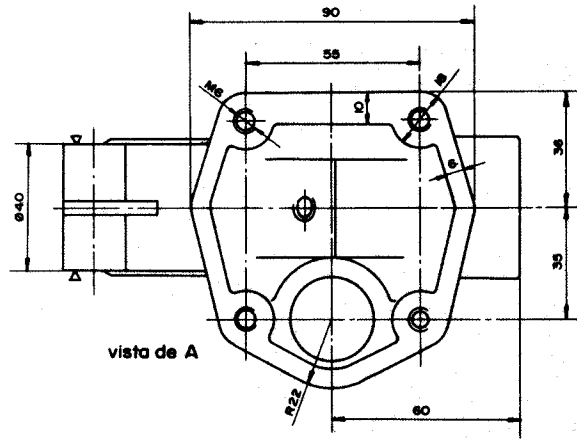

BALANCIUM

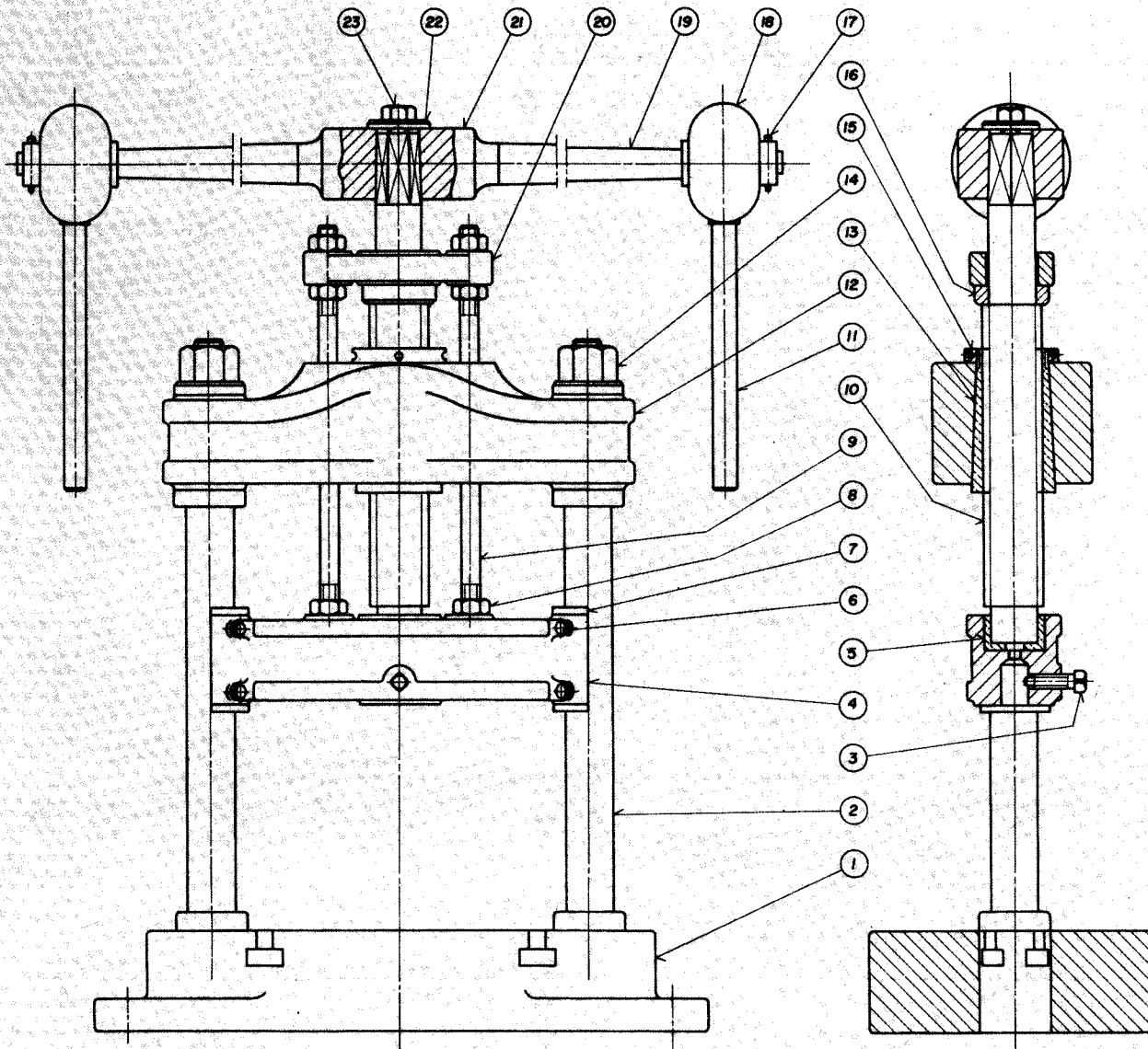

23	Parafuso sext.	1	M12x35
22	Arruela	1	Ø15xØ50x6
21	Suporte do braço	1	Aço fundido 3525 AF
20	Suporte do tirante	1	Ferro fundido
19	Braços	2	Aço NB 1020 Ø38x460
18	Massa	2	Ferro fundido
17	Pinos cônicos	2	Aço NB 1030 Ø5x40
16	Arruela de escora montada sob pressão	1	Aço NB 1030 Ø38xØ68x15
15	Porca sext.	1	M64xØ80x12
14	Parcas sext.	2	M24x34
13	Porca cônica	1	Bronze SAE 660
12	Travessão superior	1	Ferro fundido
11	Manipulos	2	Ferro redondo Ø22x240
10	Fuso	1	Aço NB 1040 Ø50x550
9	Tirantes	2	Aço NB 1020
8	Parcas sext.	6	M16x13
7	Patins	2	Bronze SAE 660
6	Parafusos sext.	8	M6x18
5	Placa de escora	1	Bronze SAE 660/Ø50x30
4	Martelo	1	Ferro fundido
3	Paraf. cab. quadrada	1	M12x40
2	Colunas	2	Aço NB 1030 Ø60x520
1	Mesa	1	Ferro fundido
Nº	DENOMINAÇÕES	Quant.	MATERIAL E DIMENSÕES

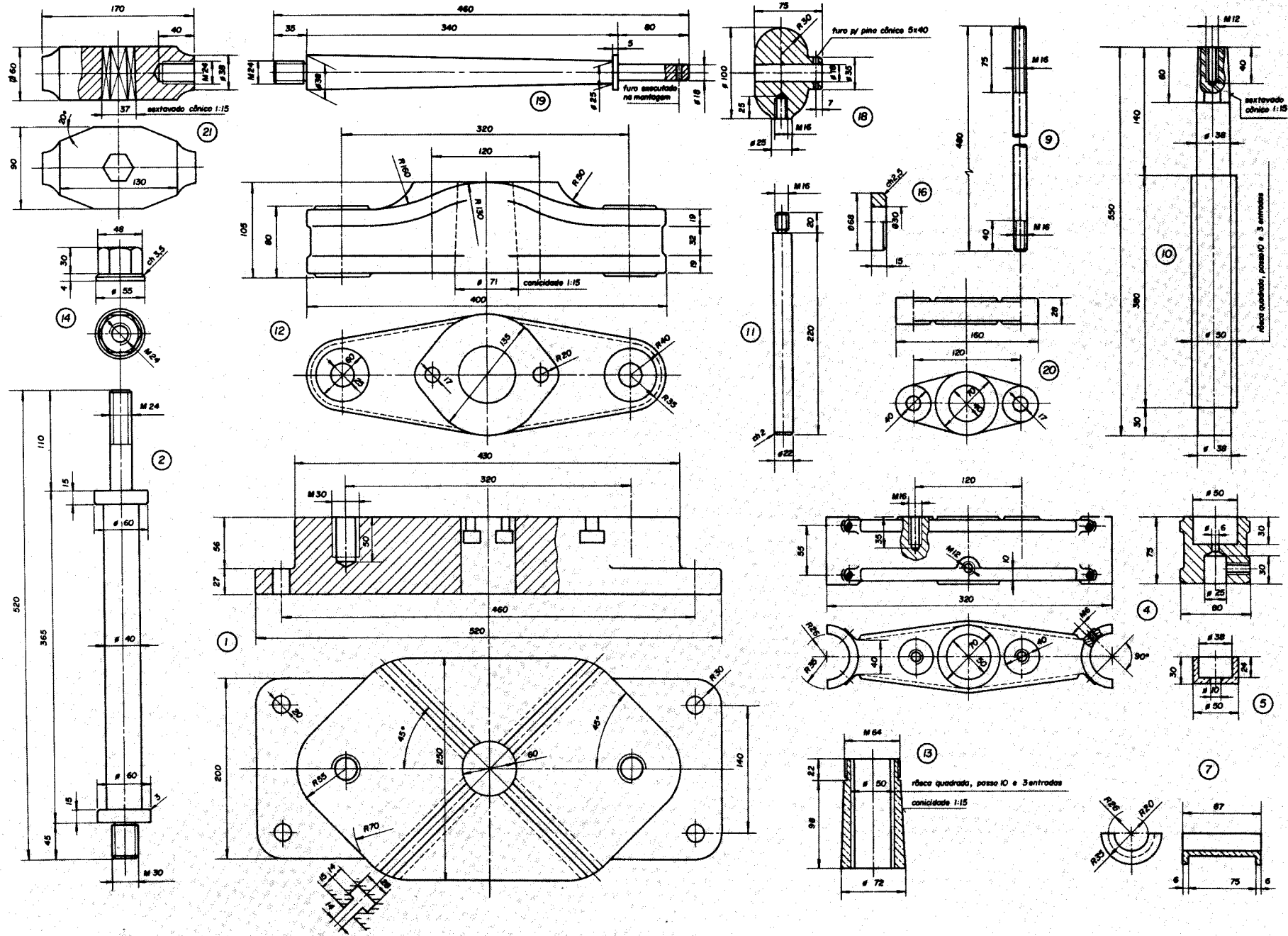

PRENSA EXCÊNTRICA

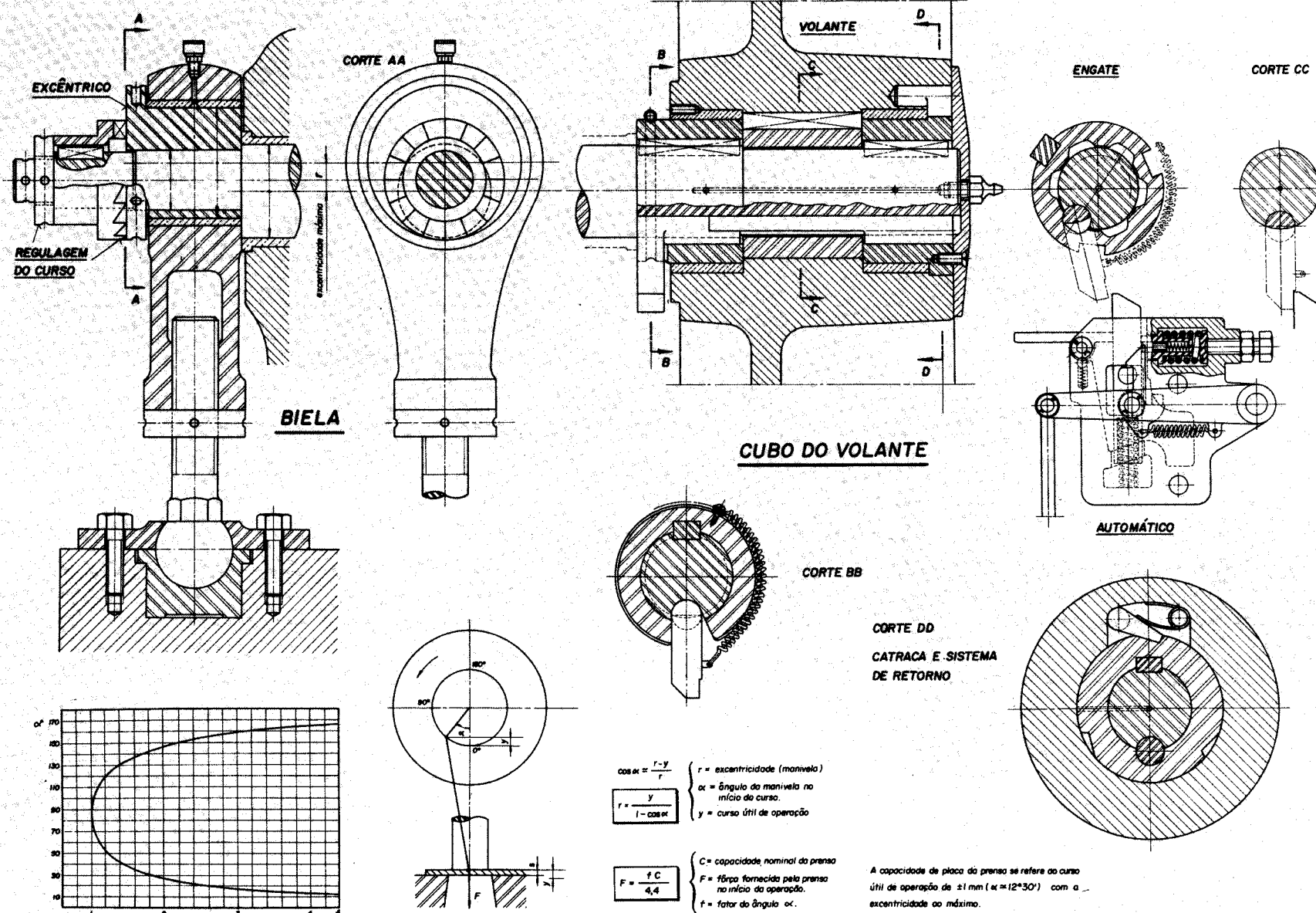

PRENSA EXCÊNTRICA DE 20 t

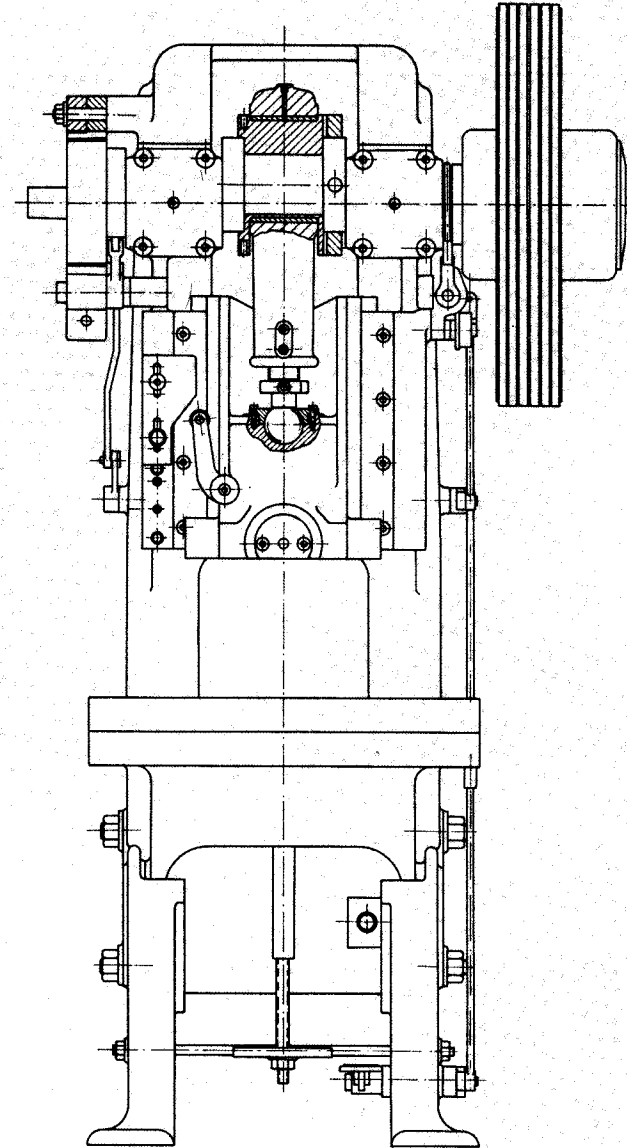
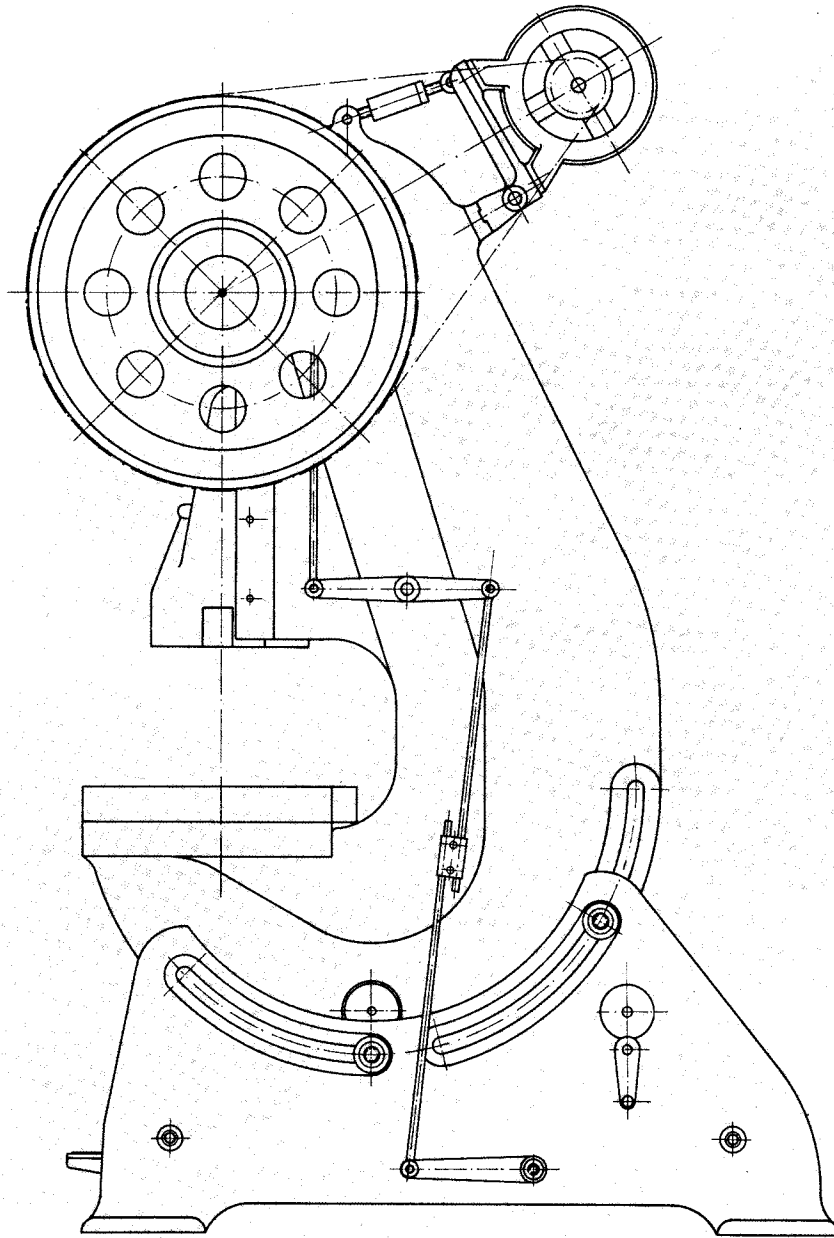

FURADEIRA DE COLUNA

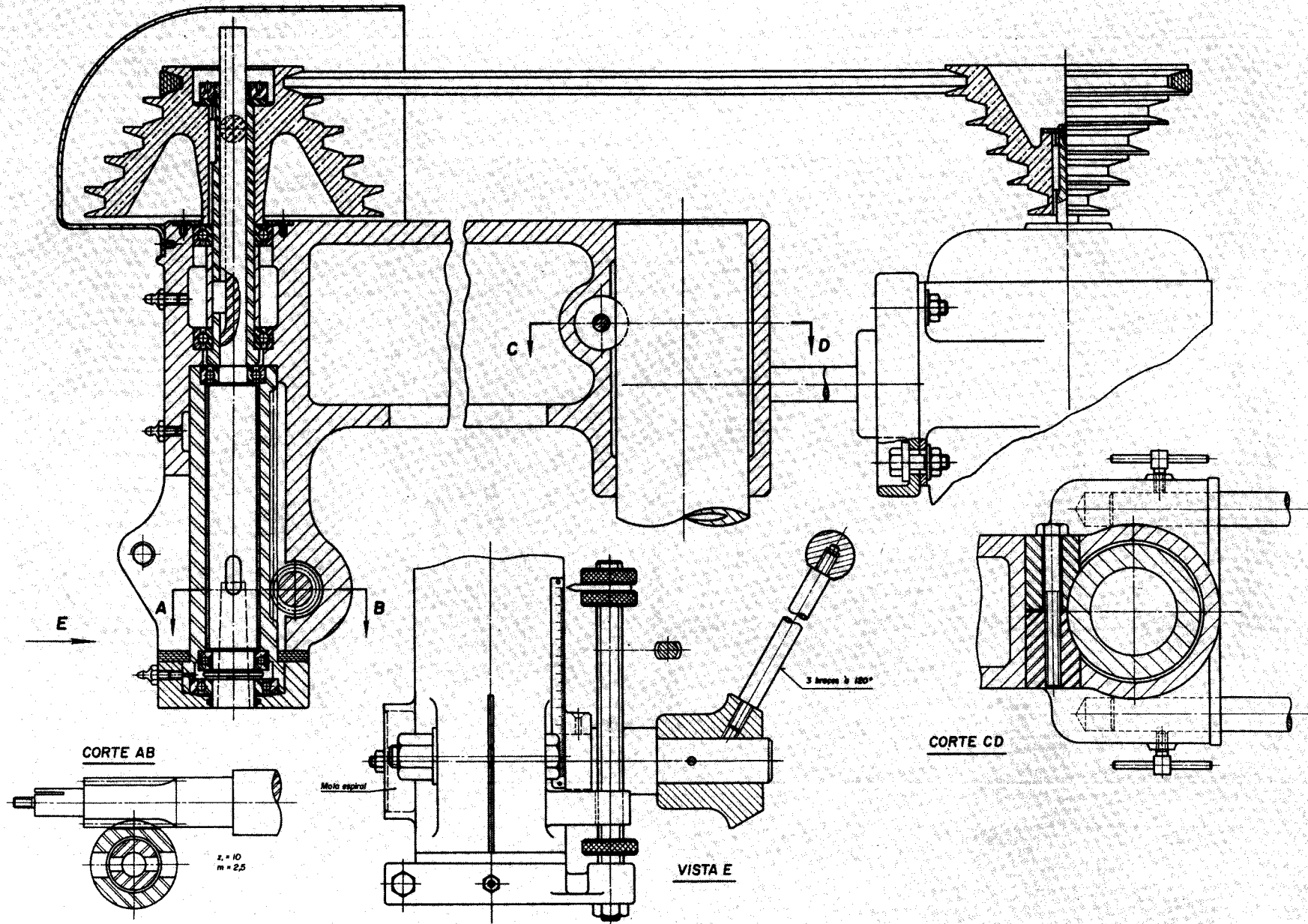

PLAINA LIMADORA

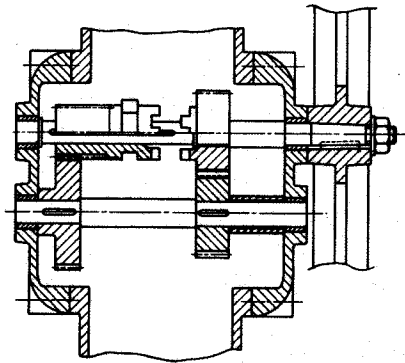

CORTE AA

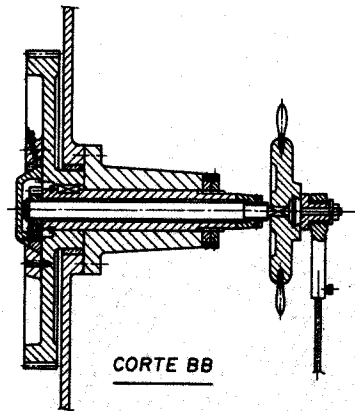

CORTE BB

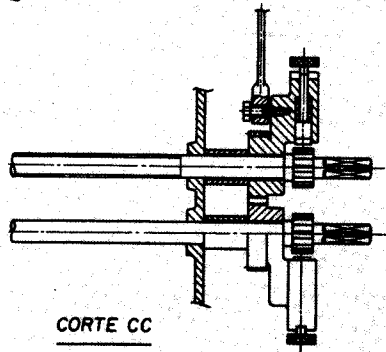

CORTE CC

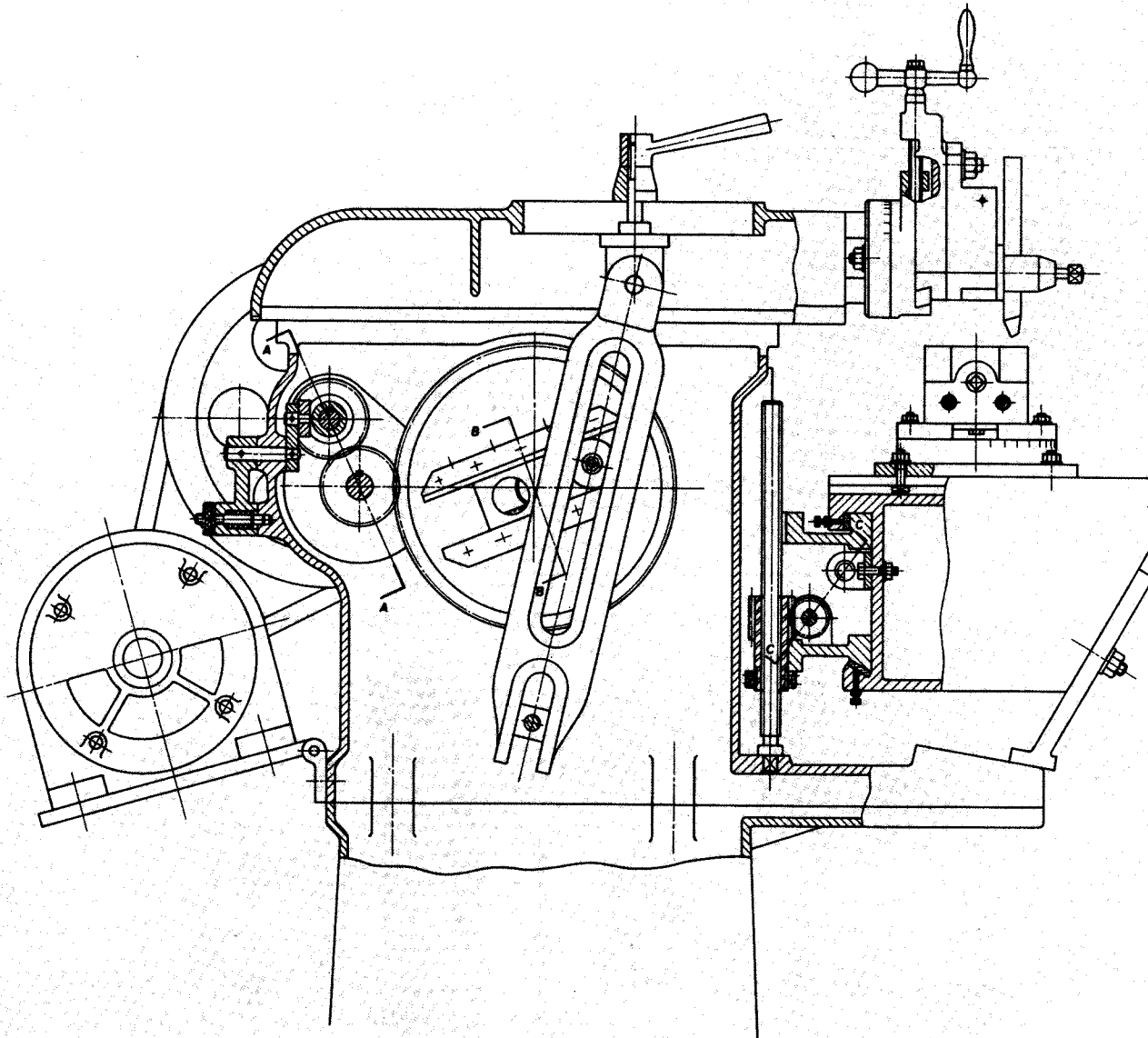

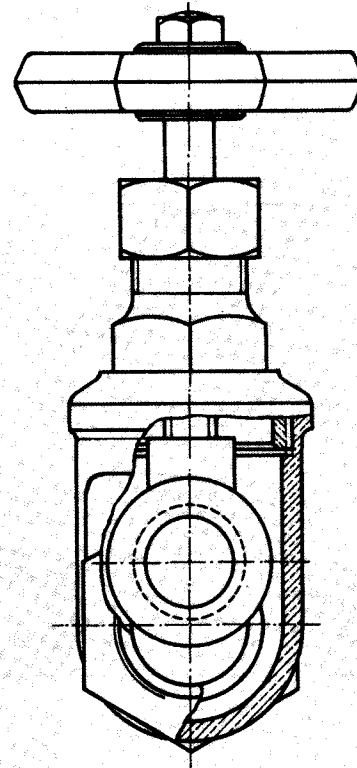
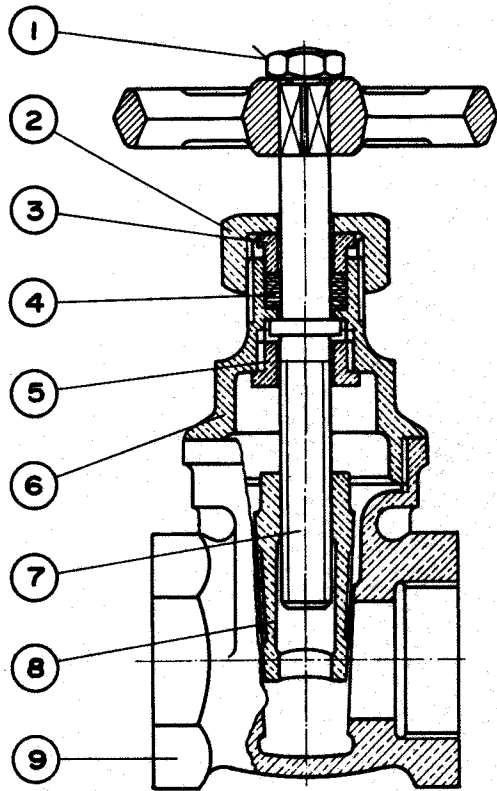

REGISTRO DE GAVETA

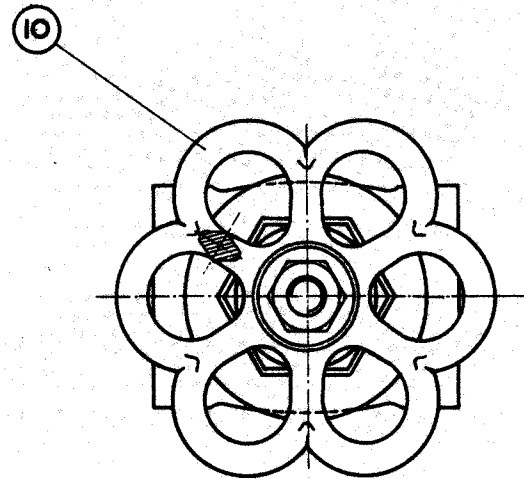







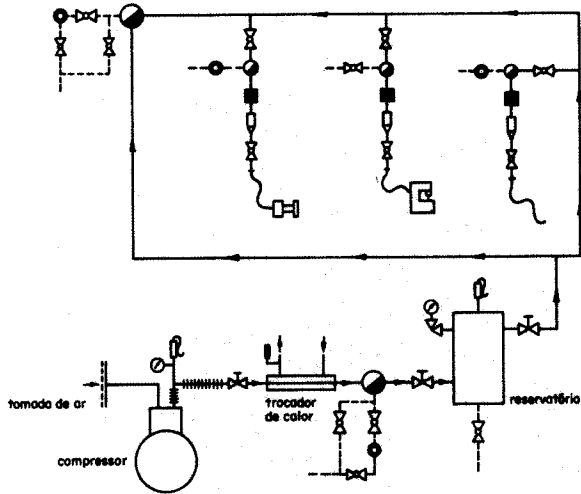





10	Volante	1	Ferro fundido
9	Carcasa	1	Bronze SAE 660
8	Gaveta	1	Bronze SAE 660
7	Fuso	1	Latão
6	Tampa	1	Bronze SAE 660
5	Bucha	1	Latão
4	Guarnição	1	Fibra Ø26 x Ø16 x 15
3	Bucha	1	Latão
2	Porca	1	Latão M 36 x 2,5
1	Porca sextavada	1	Latão M 20
Nº	DENOMINAÇÕES	Quant.	MATERIAL E DIMENSÕES

INSTALAÇÃO TÍPICA DE AR COMPRIMIDO

ESQUEMA



LEGENDA

-  registro de gaveta
-  registro globo
-  registro angular
-  separador de condensado
-  válvula de segurança
-  termômetro
-  purgador
-  manômetro
-  filtro
-  pulverizador de óleo
-  tubulação com aletas
-  tubulação de ar comprimido
-  tubulação de água condensada

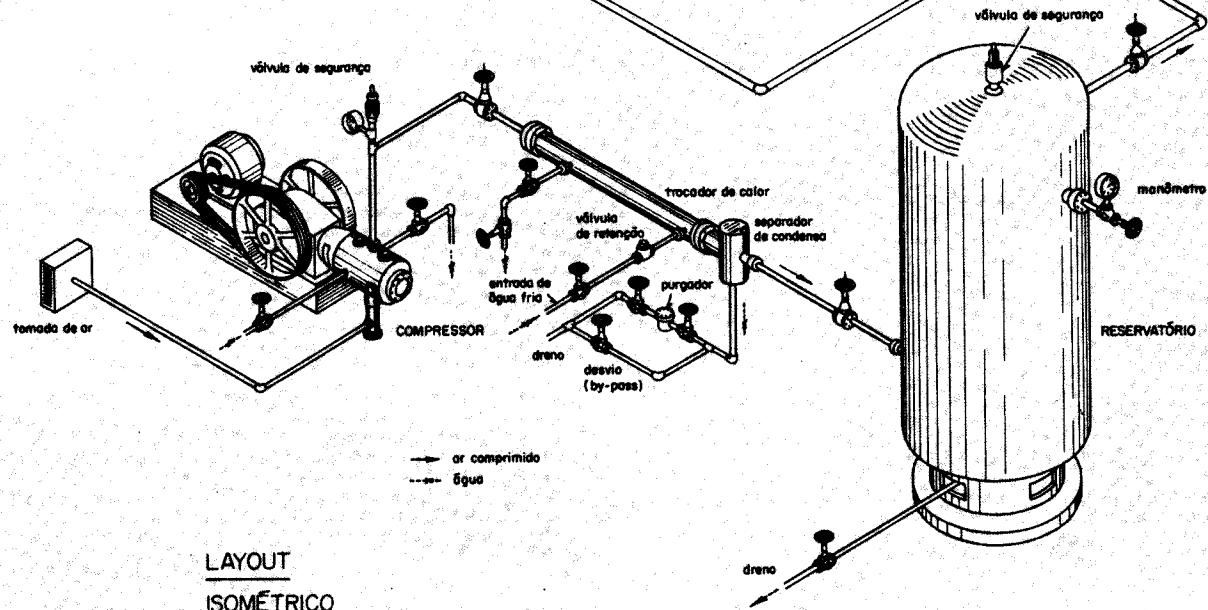
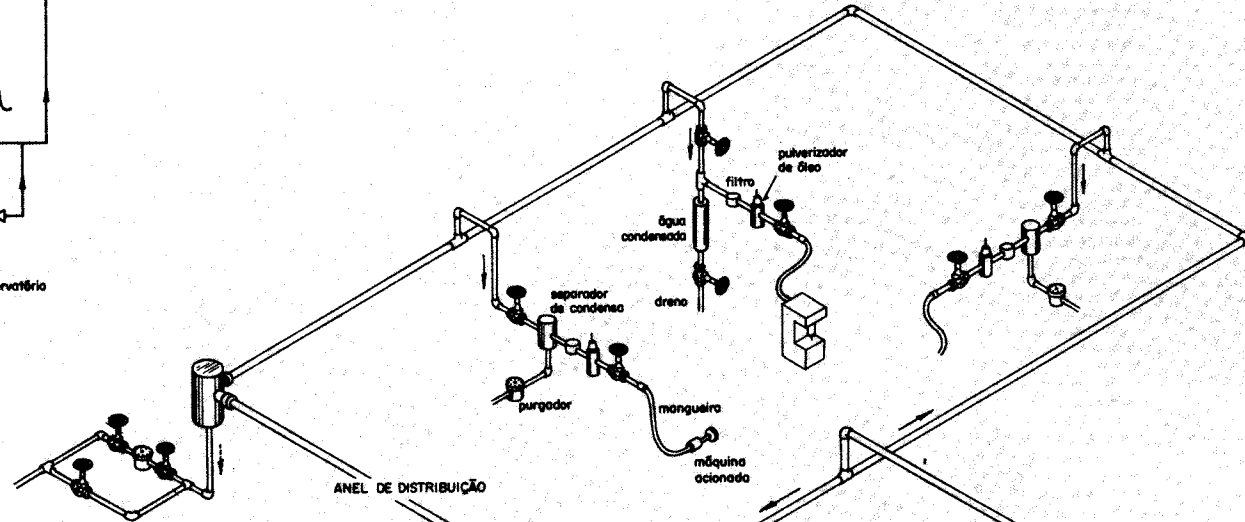

LAYOUT
 ISOMÉTRICO

INSTALAÇÃO DE AR COMPRIMIDO PARA USO INDUSTRIAL

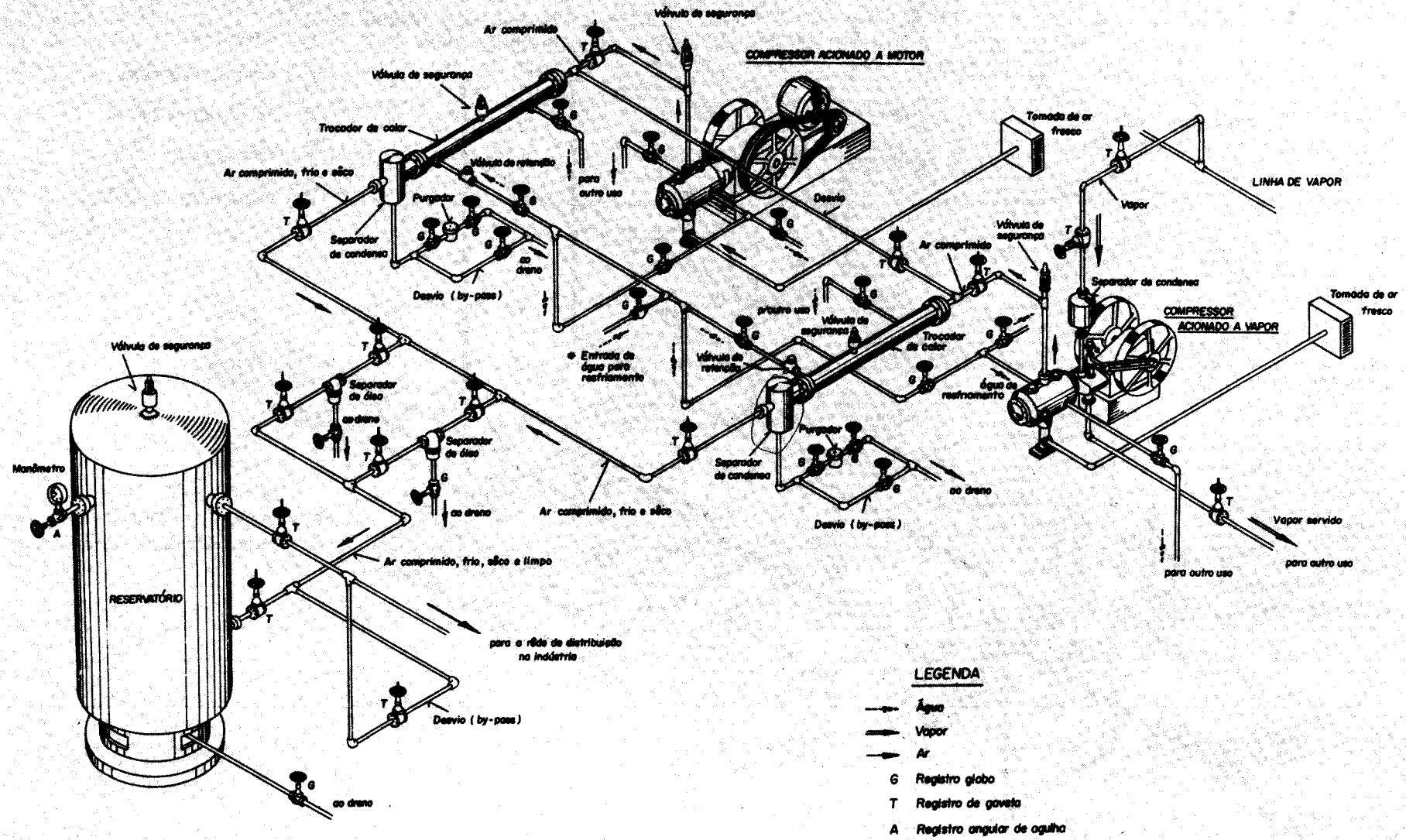

AR CONDICIONADO

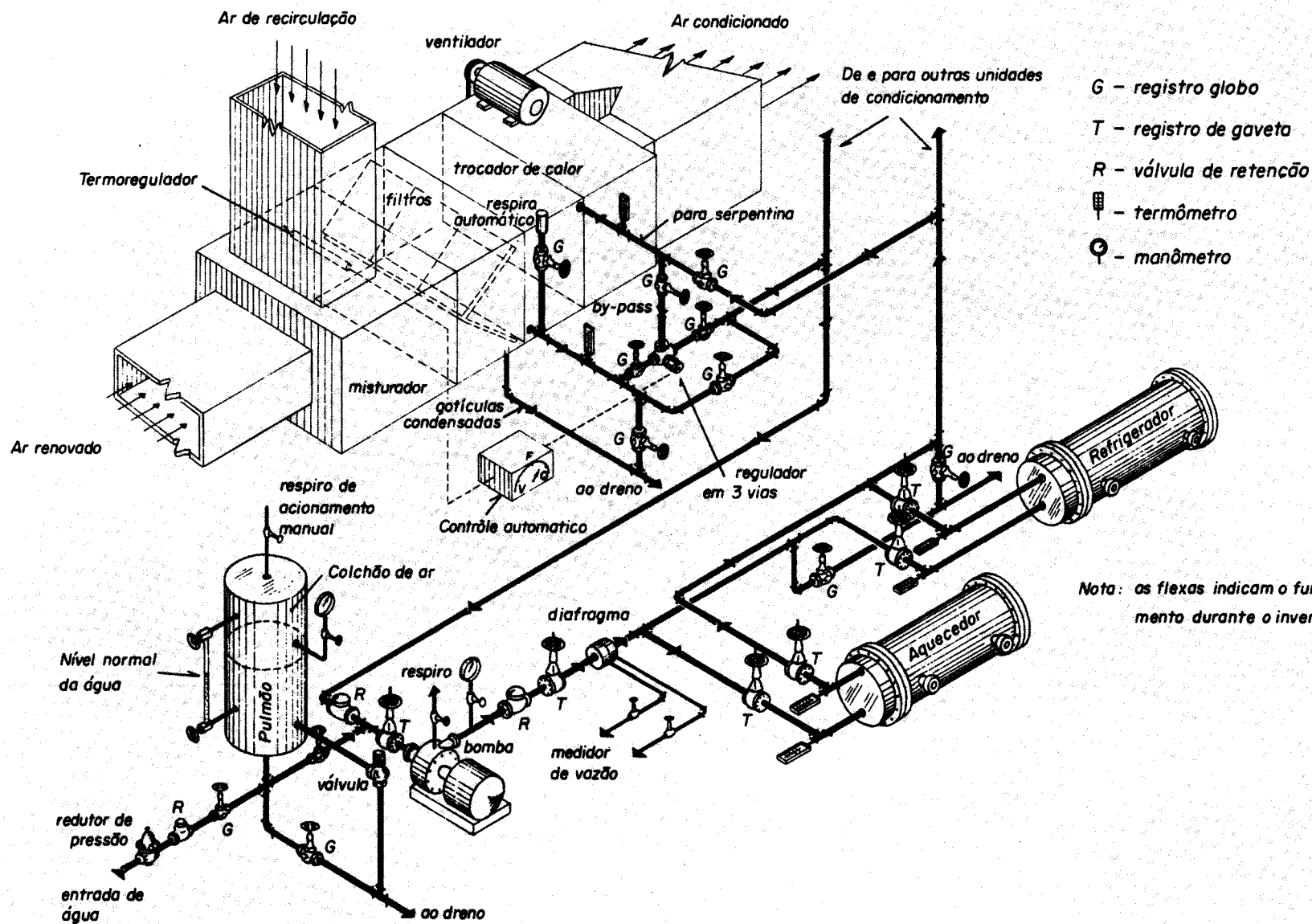

REFRIGERAÇÃO

EXEMPLOS DE SISTEMA DE REFRIGERAÇÃO POR COMPRESSÃO

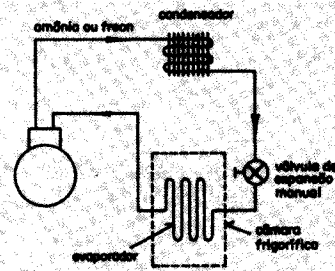

REFRIGERAÇÃO DIRETA

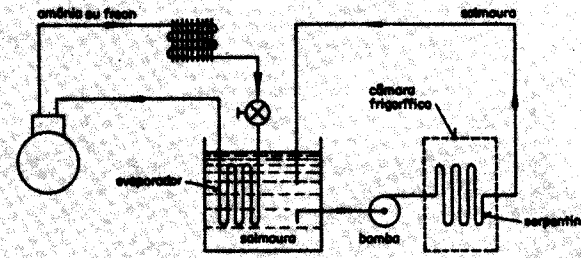

INDIRETA - COM CIRCULAÇÃO DE SALMOURA

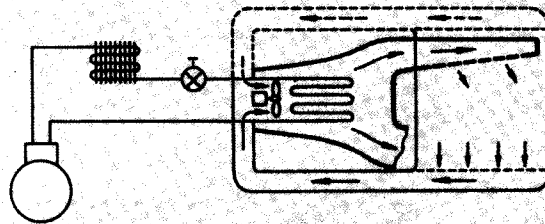

INDIRETA - COM CIRCULAÇÃO FORÇADA DE AR

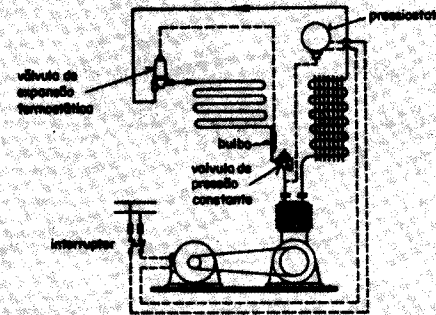

DIRETA - COM DISPOSITIVOS AUTOMÁTICOS

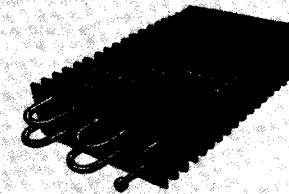

CONDENSADOR



EVAPORADOR

PRESSÃO $p > p_0$

VÁLVULA DE EXPANSÃO MANUAL

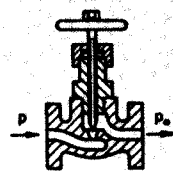

VÁLVULA DE EXPANSÃO DE TUBO CAPILAR

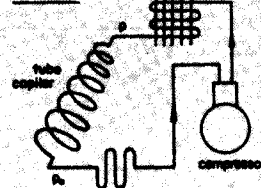

VÁLVULA DE EXPANSÃO DE PRESSÃO CONSTANTE

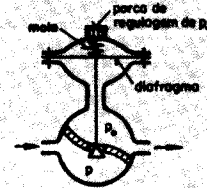

VÁLVULA DE EXPANSÃO DE BOIA

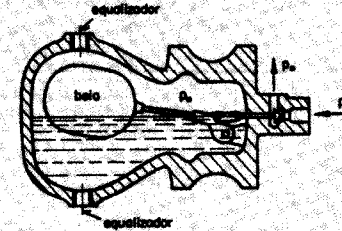

VÁLVULA DE EXPANSÃO TERMOSTÁTICA

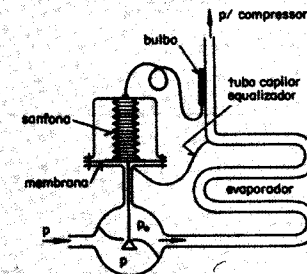

INSTALAÇÃO PARA REFRIGERAÇÃO DE SALMOURA

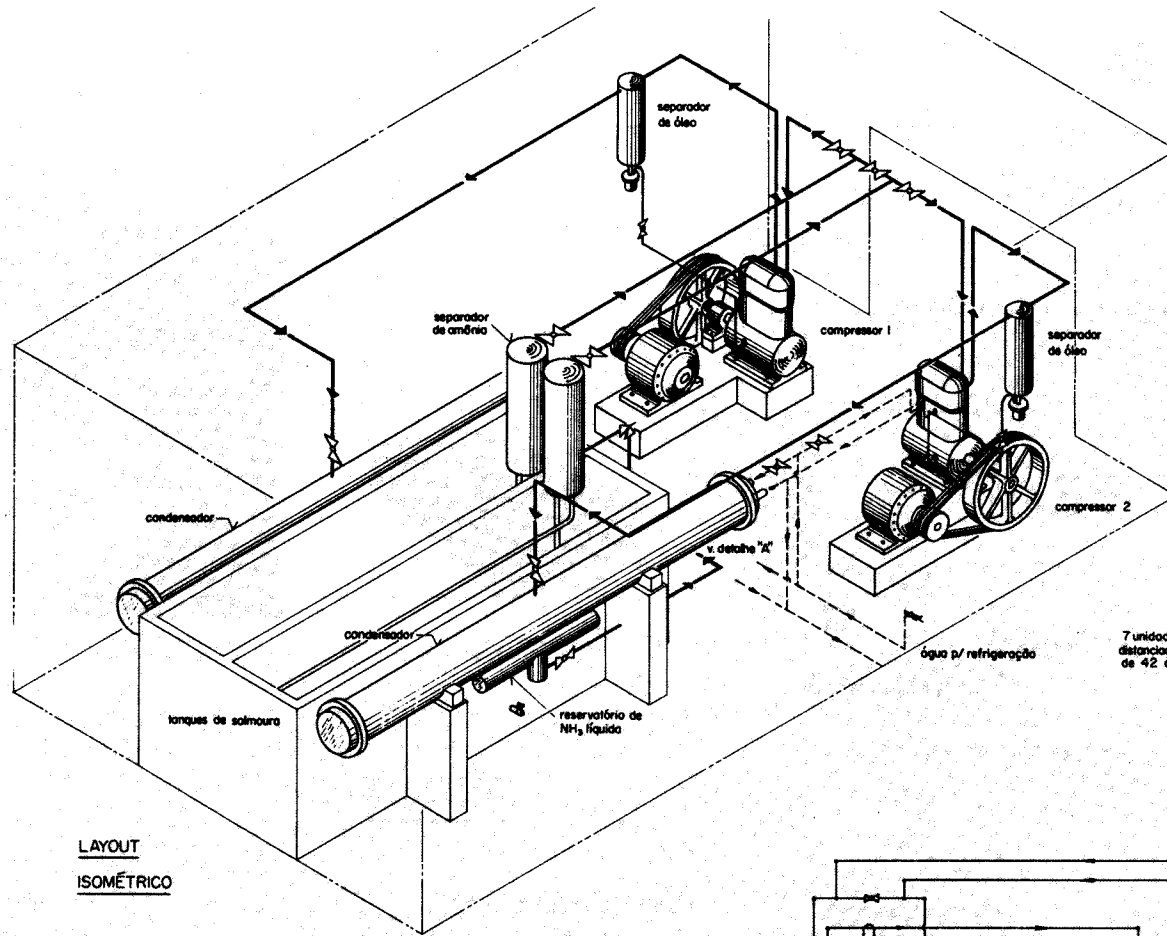

LAYOUT
ISOMÉTRICO

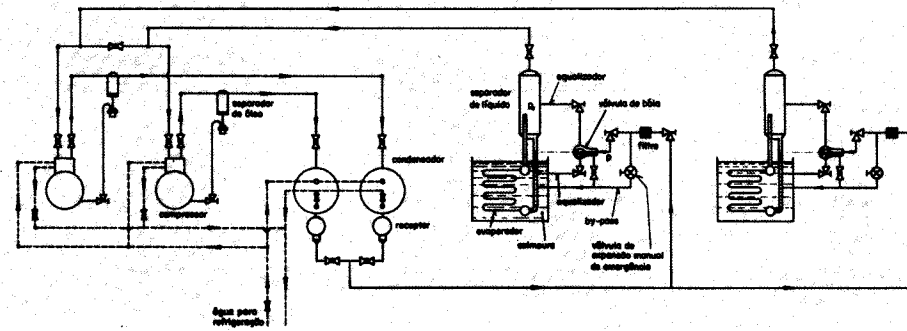
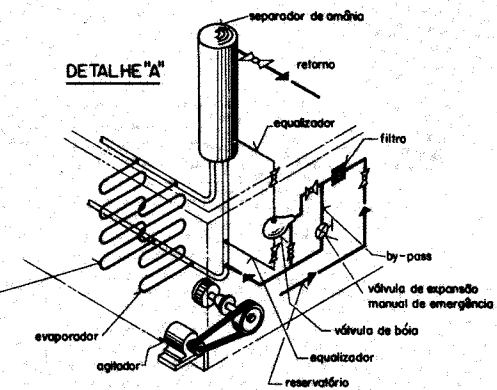

ESQUEMA

INSTALAÇÃO DE ÁGUA QUENTE

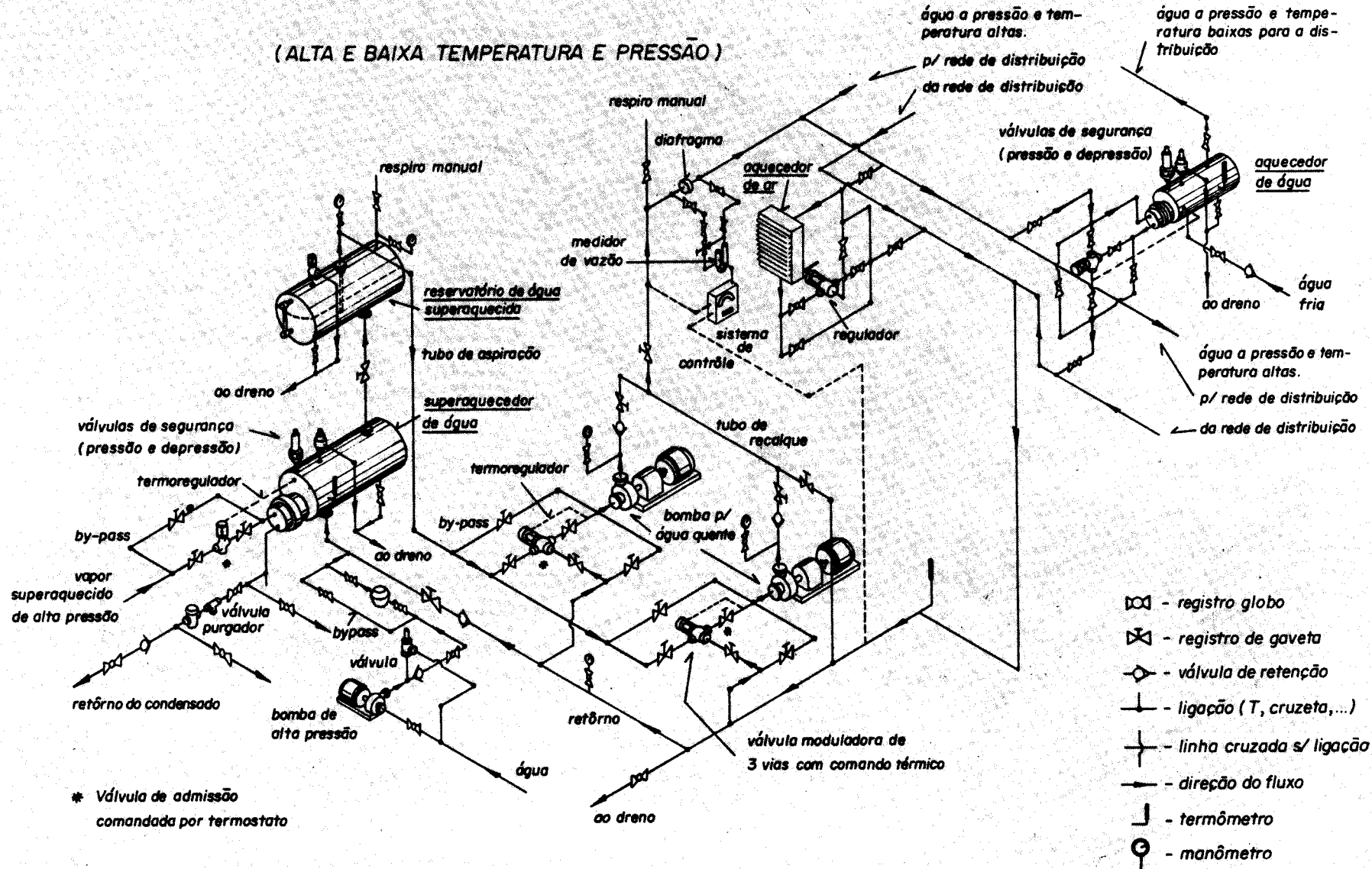

ARMAZENAGEM E VAPORIZAÇÃO DE GÁS LIQUEFEITO DE PETRÓLEO

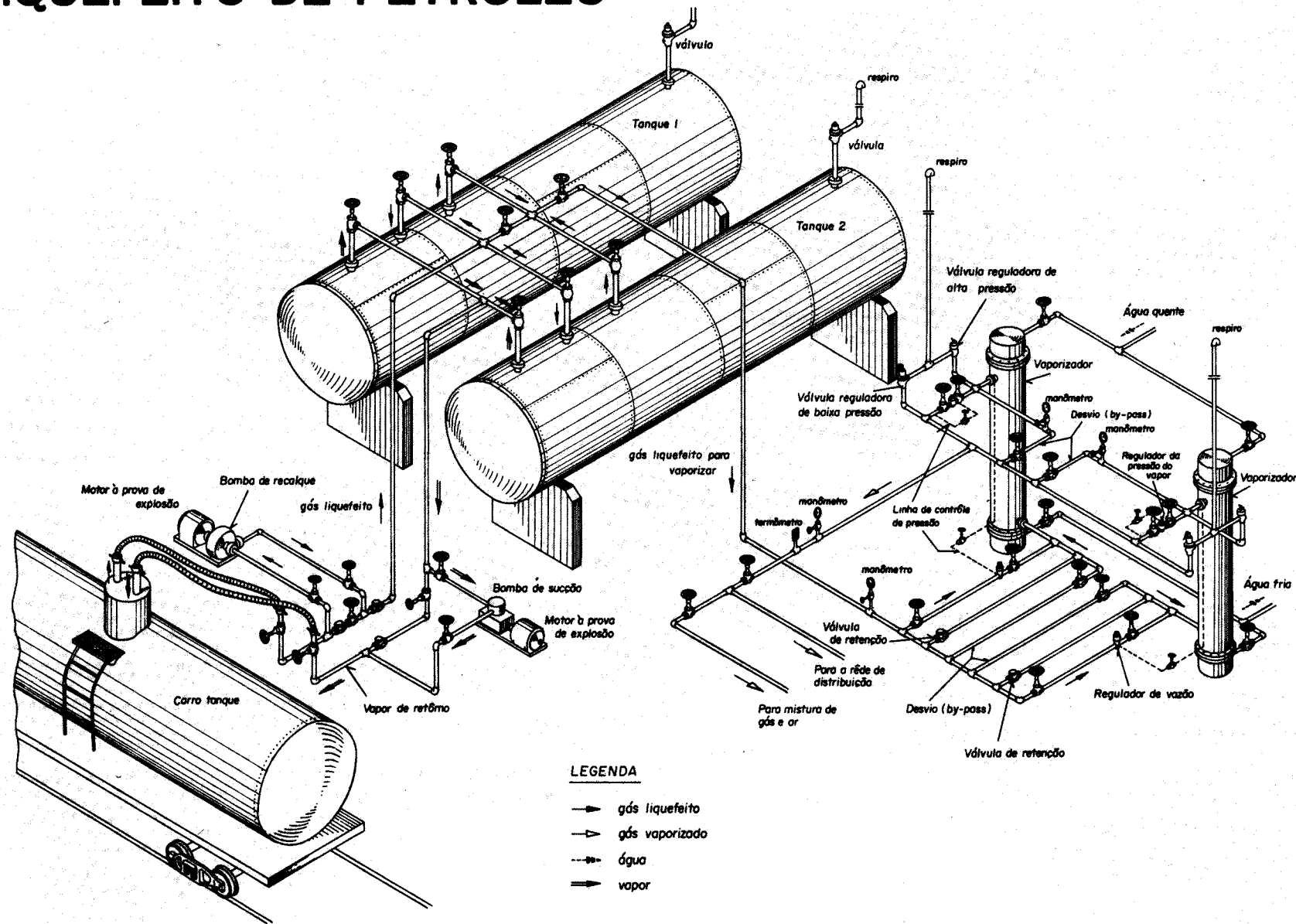

DISTRIBUIÇÃO DE ÓLEO DE QUEIMA

LAYOUT
ISOMÉTRICO

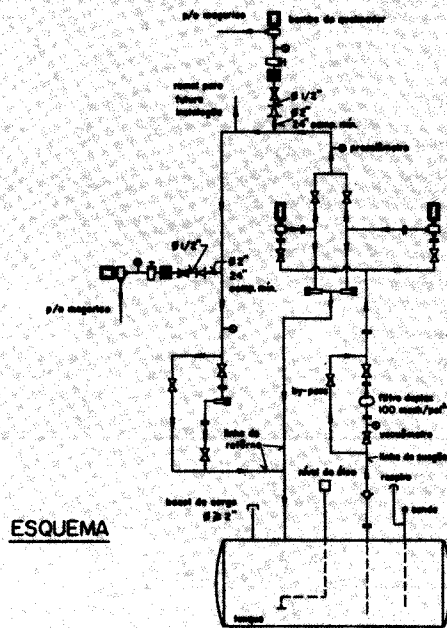
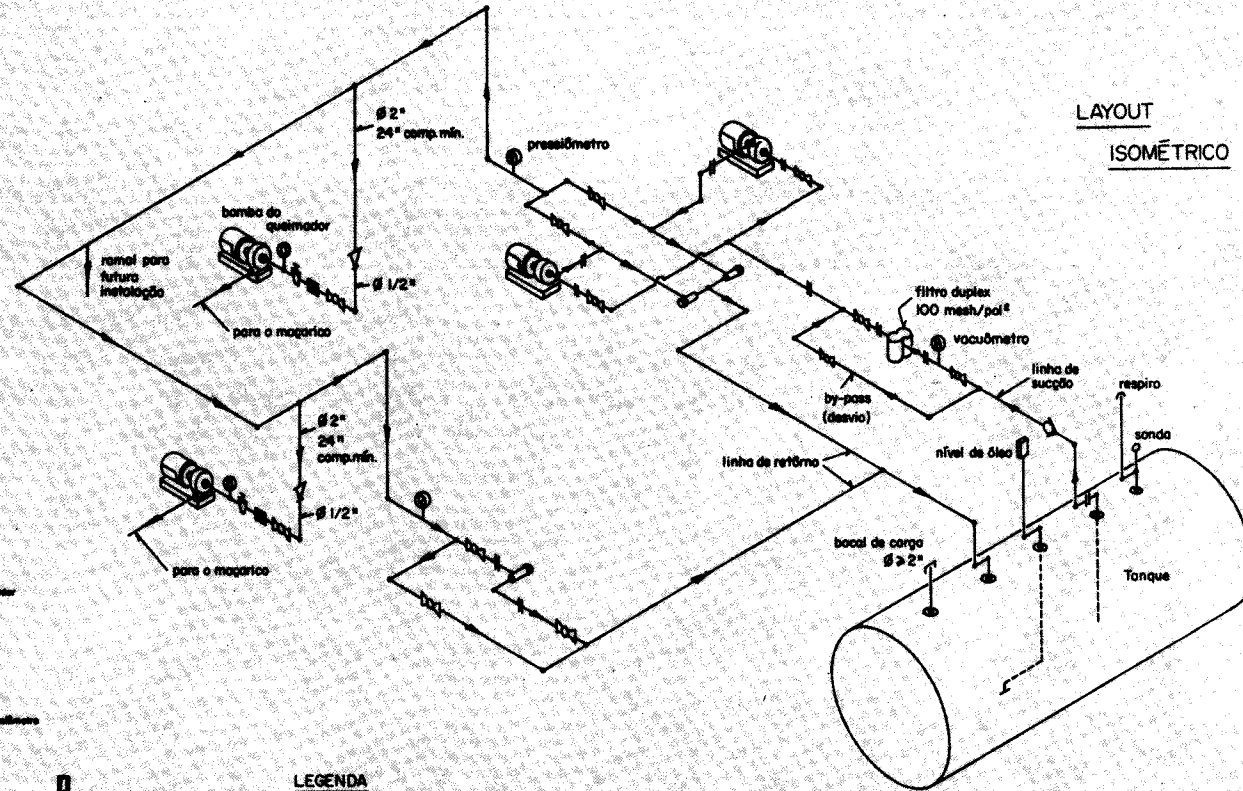

LEGENDA

- | | | | |
|--|---------------------------------|--|--------------------------------------|
| | registro de gaveta | | bomba |
| | registro globo | | ligação (T, cruzeta, etc.) |
| | válvula de retenção | | linhas cruzadas sem ligação |
| | regulador de pressão do óleo | | direção do fluxo |
| | regulador de pressão de retorno | | união |
| | filtro | | redução |
| | filtro duplex | | manômetro (vacuômetro e pressômetro) |

FERRAMENTA DE CORTE

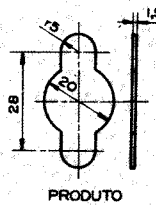
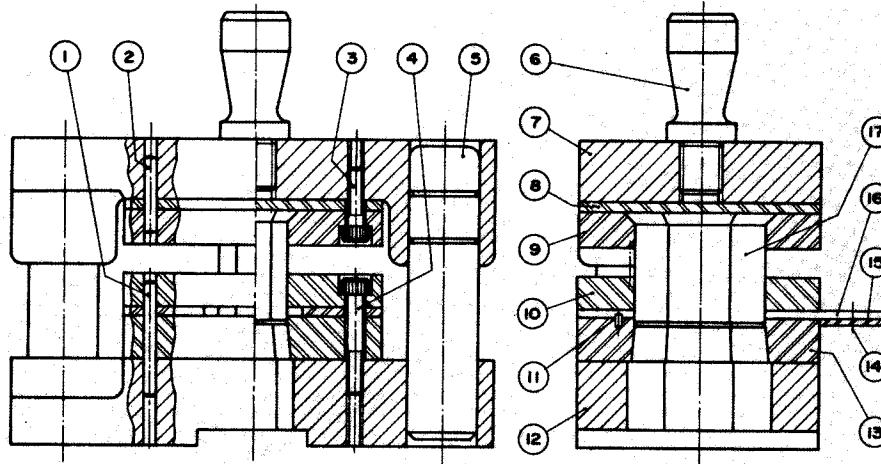
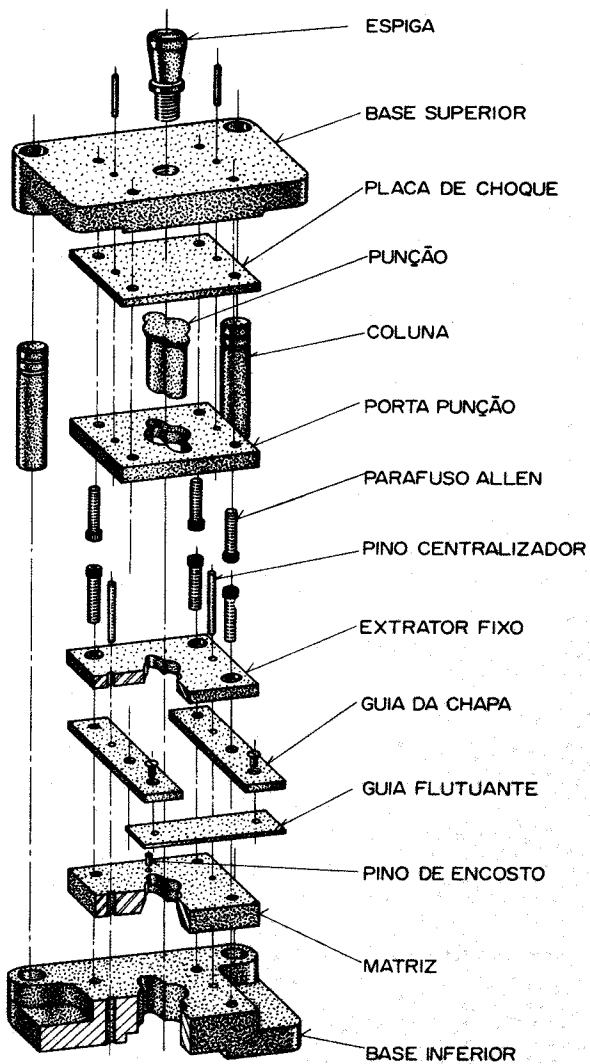

17	Punção	1	Aço RCC temp. retif.
16	Guia da chapa	2	Aço NB 1010
15	Guia flutuante	1	Aço NB 1010
14	Paraf. cab. chata	2	Ø1/2" x 5
13	Matriz	1	Aço RCC temp. retif.
12	Base inferior	1	Ferro fundido
11	Pino de encosto	1	Aço prata Ø2x4
10	Extrator fixo	1	Aço NB 1030
9	Porta punção	1	Aço NB 1020
8	Placa de choque	1	Aço NB 1045 temp. retif.
7	Base superior	1	Ferro fundido
6	Espiga	1	Aço NB 1020
5	Coluna	2	Aço NB 1020 Ø20x85
4	Paraf. Allen	4	# 10 x 18
3	Paraf. Allen	4	# 10 x 30
2	Pino centralizador	2	Aço prata Ø3m6 x 20
1	Pino centralizador	2	Aço prata Ø3m6 x 30
Nº	DENOMINAÇÕES		MATERIAL E DIMENSÕES

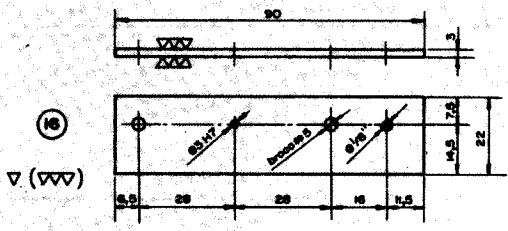
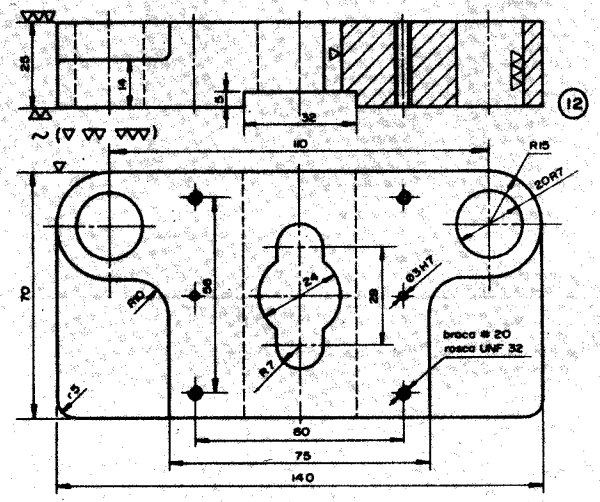
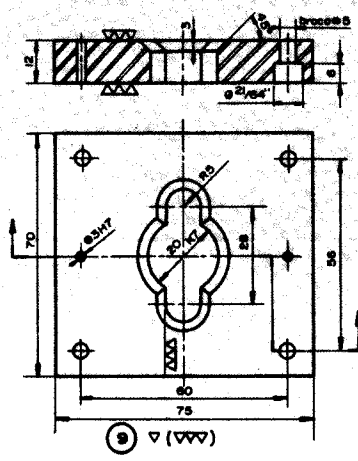
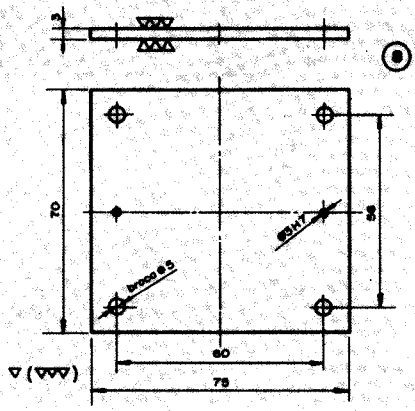
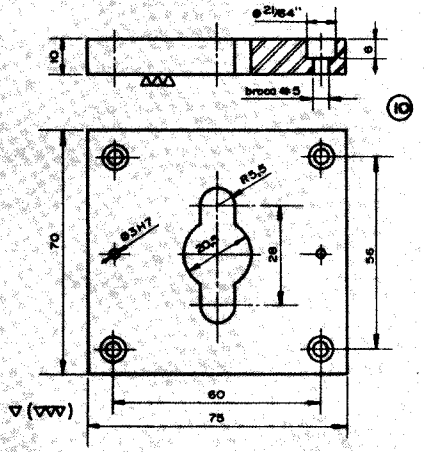
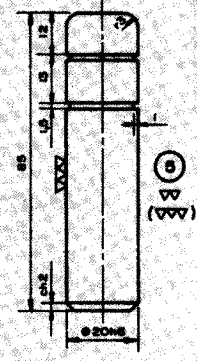
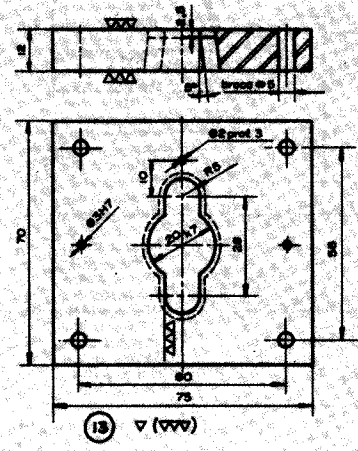
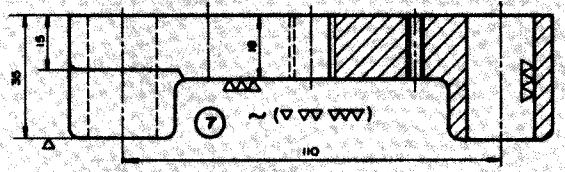
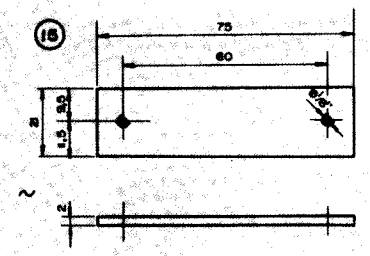
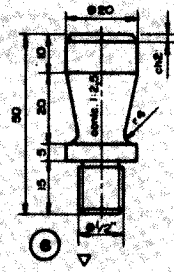
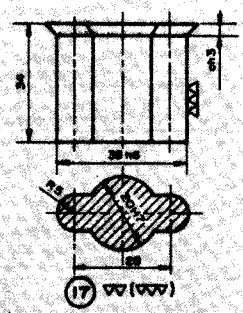
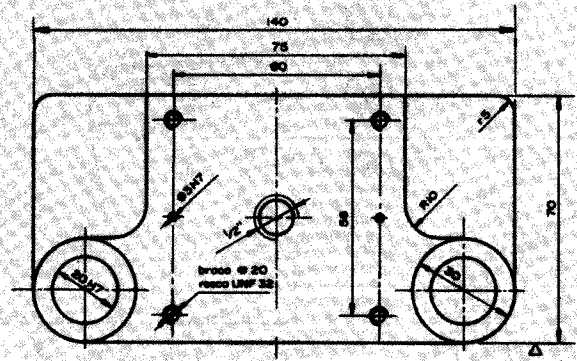

FERRAMENTA DE DOBRA

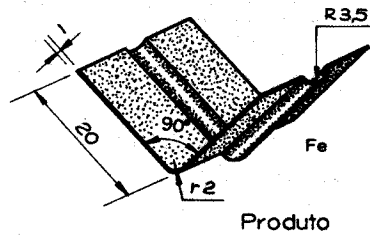
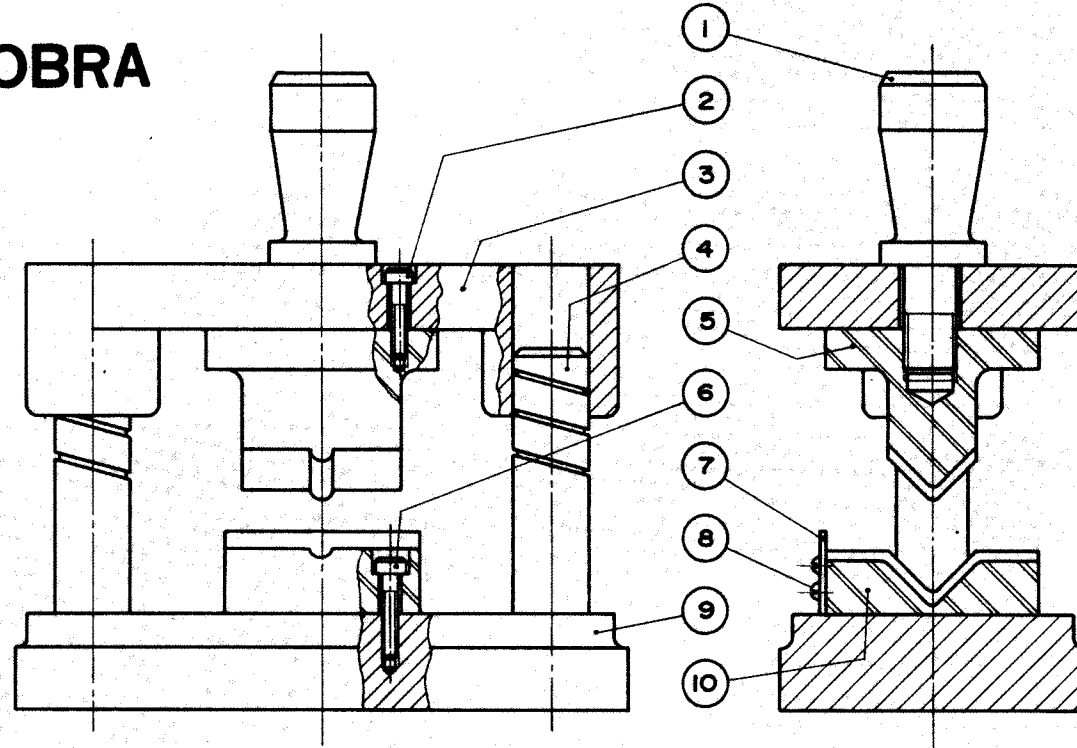
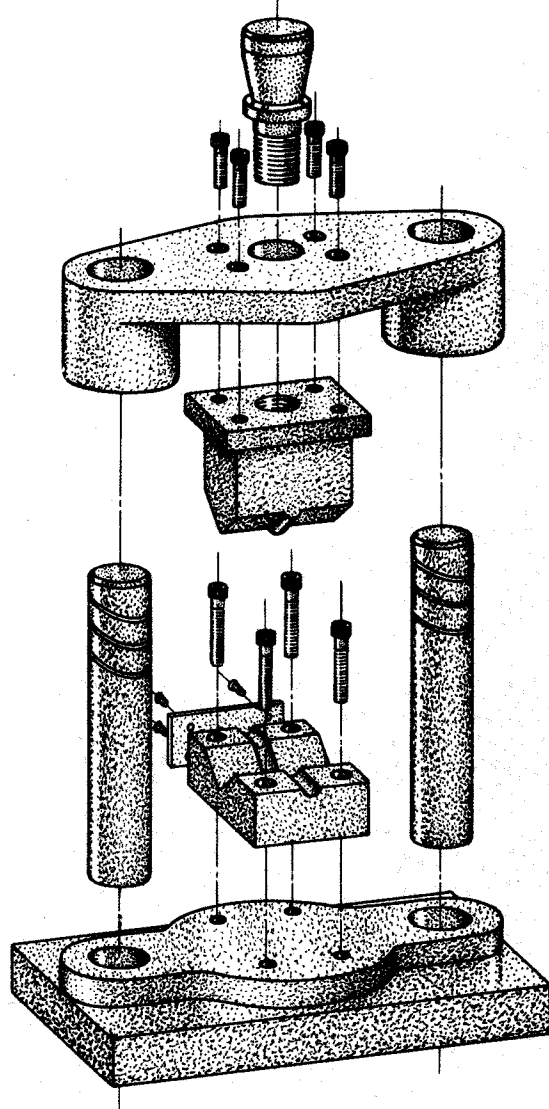

10	Matriz	1	Aço RCC retificado e temp.
9	Base inferior	1	Ferro fundido
8	Paraf. de fenda	4	$\varnothing 3/32" \times 4$
7	Encosto	1	Chapa preta # 16
6	Parafuso Allen	4	# 10x13
5	Punção	1	Aço RCC retificado e temp.
4	Coluna	2	Aço NB 1020 $\varnothing 14 \times 68$
3	Base superior	1	Ferro fundido
2	Parafuso Allen	4	# 10x13
1	Espiga	1	Aço NB 1020
Nº	DENOMINAÇÕES	Quant.	MATERIAL E DIMENSÕES

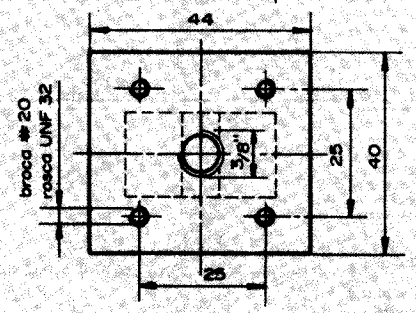
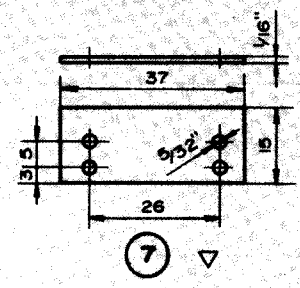
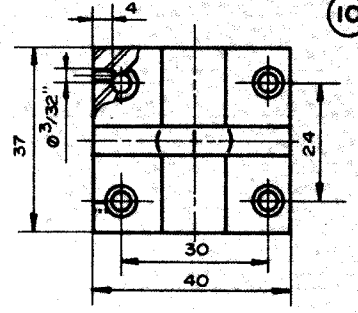
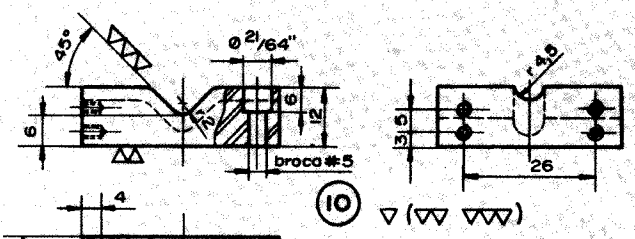
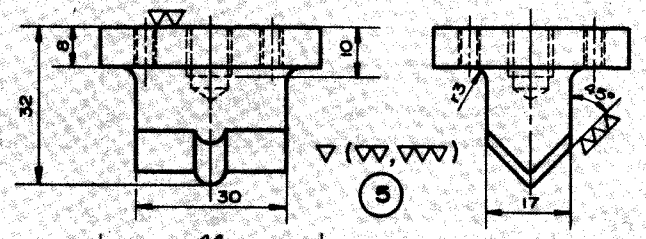
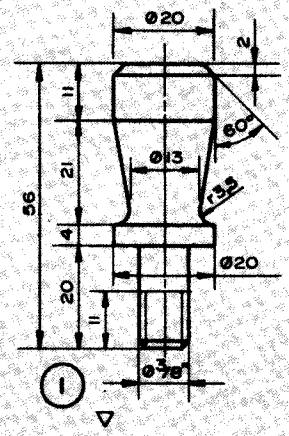
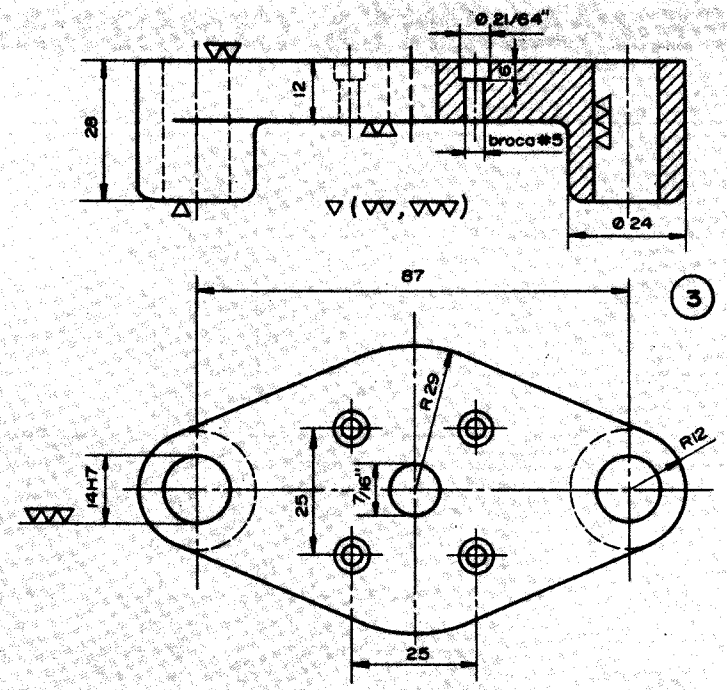
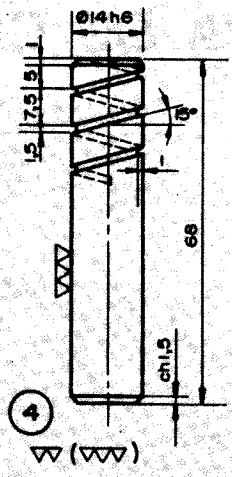
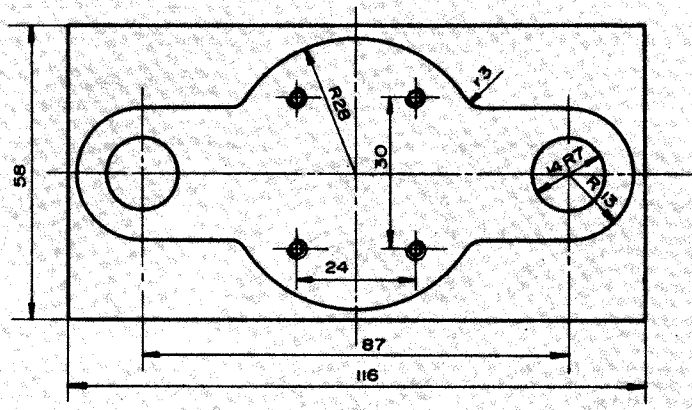
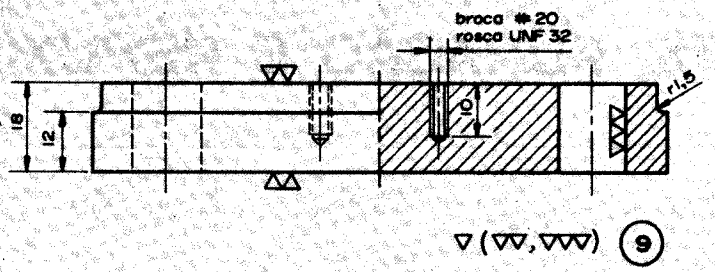

FERRAMENTA COMBINADA DE CORTE, FURAÇÃO E REPUXO

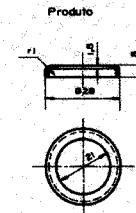
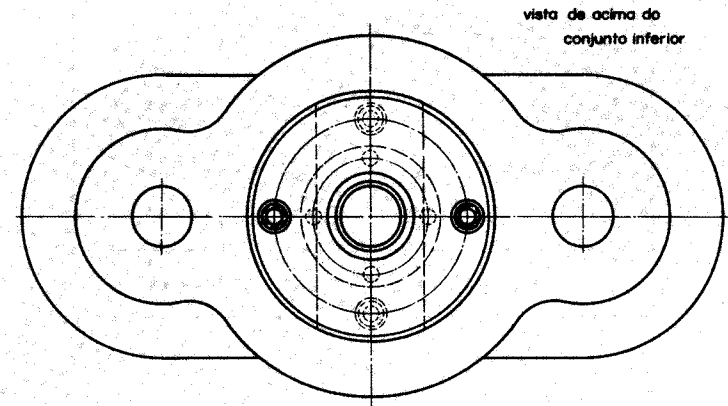
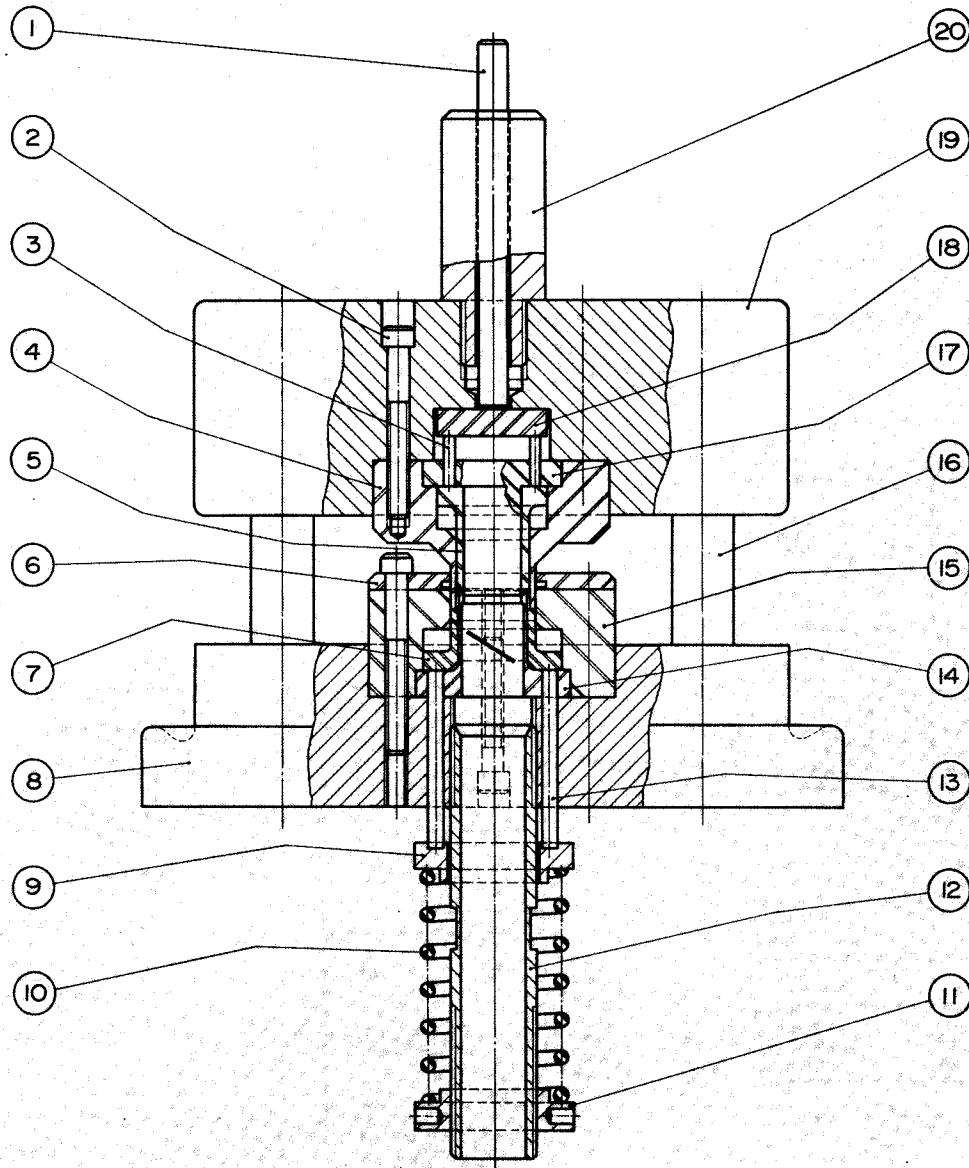

20	Espejo	1	Aço NB 1010
19	Base superior	1	Ferro fundido
18	Placa de choque	1	Aço NB 1045 temp. rev. ref.
17	Punção de corte	1	Aço V1W-130
16	Coluna	2	Aço V1ND Ø 7/8"
15	Matriz de raposo	1	Aço V1W-130
14	Matriz	1	Aço V1W-130
13	Pino extrator	4	Aço prata Ø 1/4" x 65
12	Parafuso da mala	1	Ø 33,5 x 180
11	Parca reguladora	1	Aço NB 1010
10	Mala	1	Aço NB 1065
9	Disco de mala	1	Aço NB 1020
8	Base inferior	1	Ferro fundido
7	Extrator inferior	1	Aço NB 1045
6	Extrator fino	1	Aço NB 1030
5	Sugetador	1	Aço NB 1040
4	Punção de raposo	1	Aço V1W-130 temp. rev. ref.
3	Pino extrator	4	Aço prata temp. rev. ref. Ø 3/8" x 65
2	Parafuso Allen	8	Ø 5/16" x 65
1	Varão	1	Aço NB 1010
NR	DENOMINAÇÕES		MATERIAL E DIMENSÕES

FERRAMENTA COMBINADA DE CORTE, FURAÇÃO E DOBRA

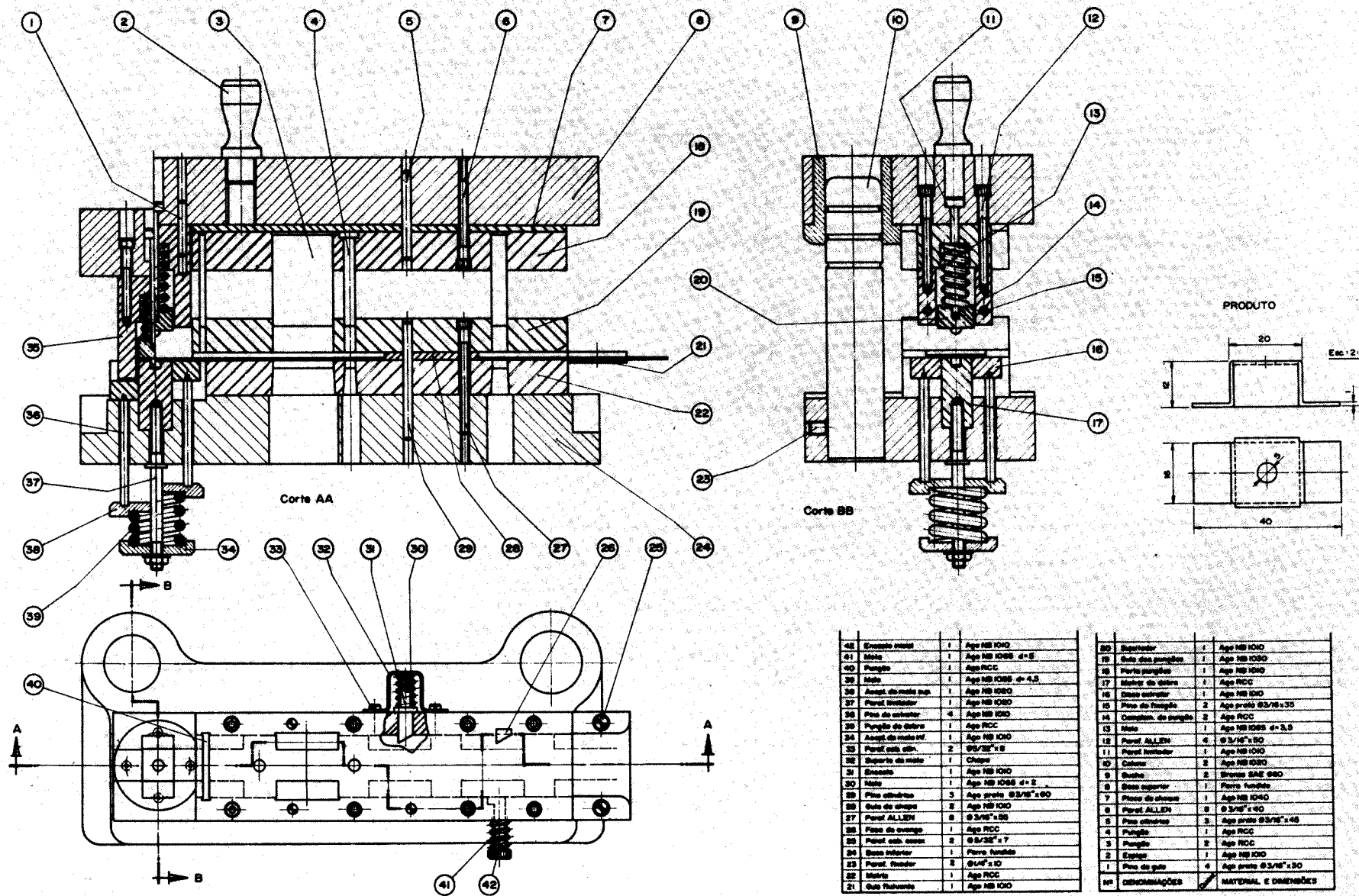

42	Erroto moel	1	Aço HB 1040
41	Mola	1	Aço HB 1088 d=5
40	Punção	1	Aço RCC
39	Mola	1	Aço HB 1088 d=4,5
38	Acopl. do mato sup.	1	Aço HB 1080
37	Paraf. Instalar	1	Aço HB 1080
36	Peça de arator	4	Aço HB 1080
35	Punção de dobra	1	Aço RCC
34	Acopl. do mato inf.	1	Aço HB 1080
33	Paraf. cas. est.	2	Ø5/32" x 8
32	Supporto do mato	1	Chapa
31	Encaixe	1	Aço HB 1080
30	Mola	1	Aço HB 1088 d=2
29	Peça dobrada	3	Aço preto Ø3/16" x 60
28	Chave de chave	2	Aço HB 1080
27	Paraf. ALLEN	8	Ø 3/16" x 20
26	Peça de encaixe	1	Aço RCC
25	Paraf. cas. com.	2	Ø 3/32" x 7
24	Recebo inferior	1	Ferro fundido
23	Paraf. fixador	2	Ø1/4" x 10
22	Mola	1	Aço RCC
21	Sub. flange	1	Aço HB 1080

20	Superfície	1	Aço HB 1080
19	Sub. dos parafusos	1	Aço HB 1080
18	Paraf. parafuso	1	Aço HB 1080
17	Molde de guia	1	Aço RCC
16	Recebo superior	1	Aço HB 1080
15	Peça de flange	2	Aço preto Ø3/16" x 35
14	Componente de punção	2	Aço RCC
13	Mola	1	Aço HB 1088 d=3,5
12	Paraf. ALLEN	6	Ø 3/16" x 50
11	Paraf. Instalar	1	Aço HB 1080
10	Chapa	2	Aço HB 1080
9	Chapa	2	Presso SAE 680
8	Recebo superior	1	Ferro fundido
7	Peça de chave	1	Aço HB 1080
6	Paraf. ALLEN	8	Ø 3/16" x 40
5	Peça dobrada	3	Aço preto Ø3/16" x 40
4	Punção	1	Aço RCC
3	Punção	2	Aço RCC
2	Espiga	1	Aço HB 1080
1	Peça de guia	4	Aço preto Ø3/16" x 30
NP	DESCRIÇÕES		MATERIAL E DIMENSÕES

FERRAMENTA PROGRESSIVA DE CORTE E REPUXO

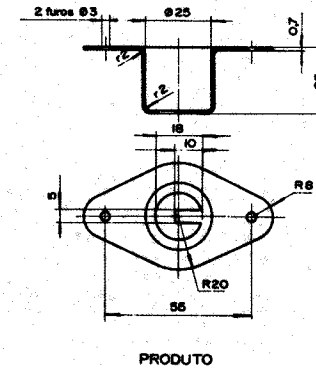
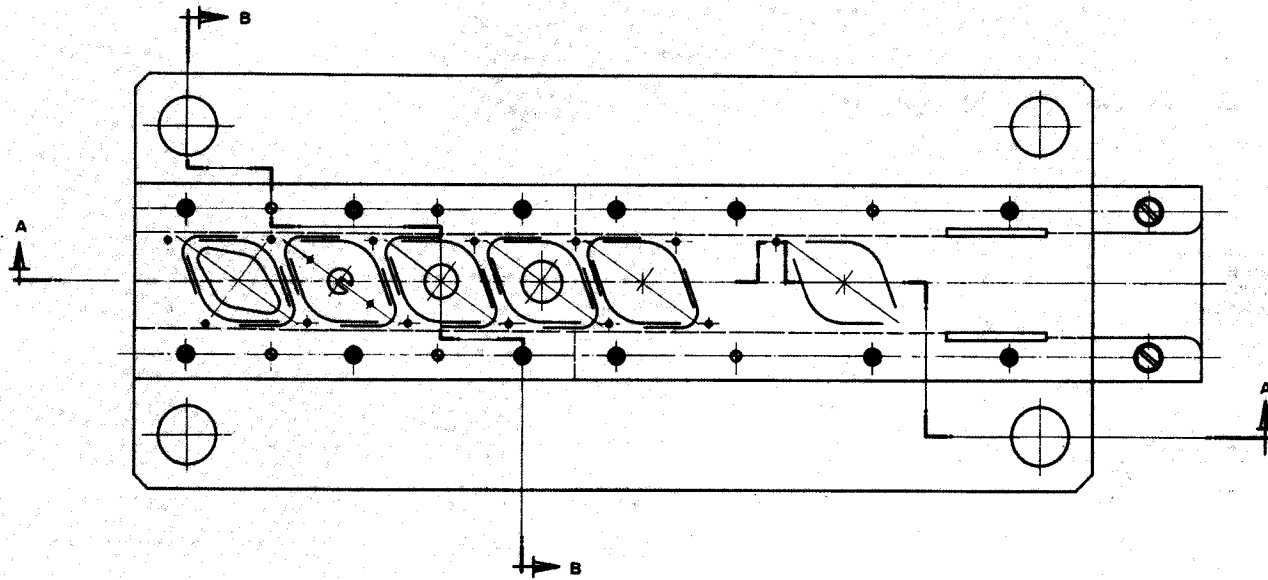
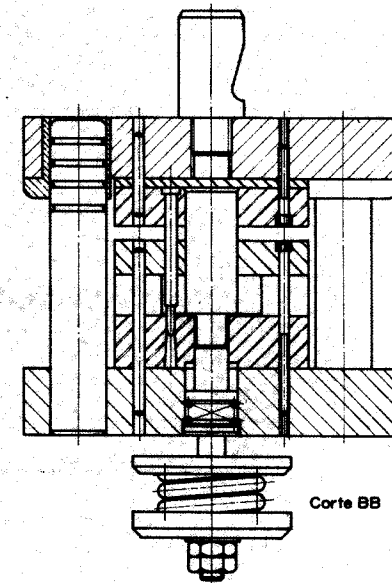
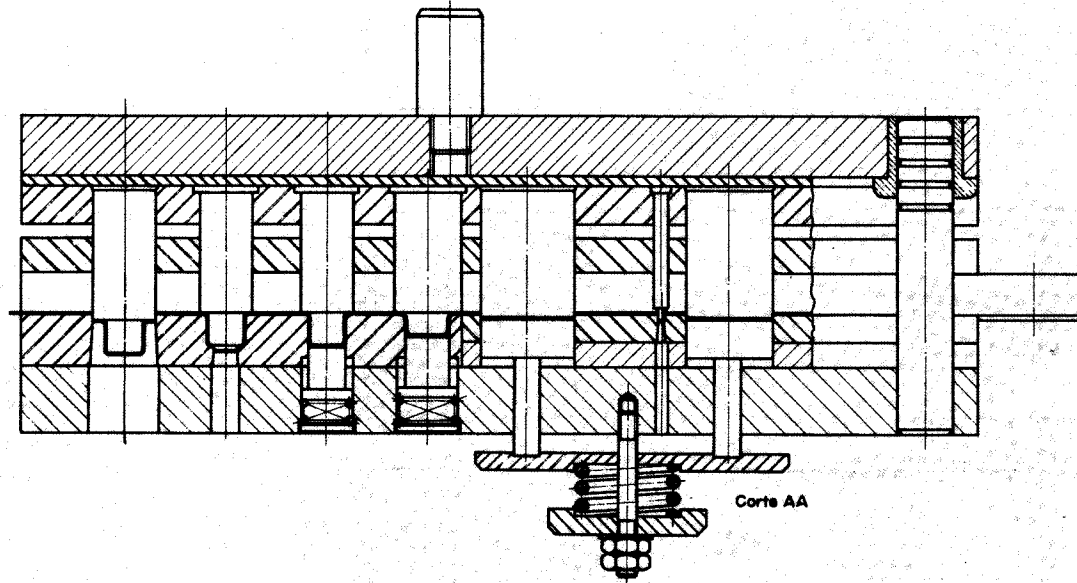

FERRAMENTA PROGRESSIVA DE CORTE E REPUXO

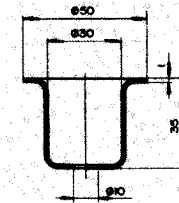
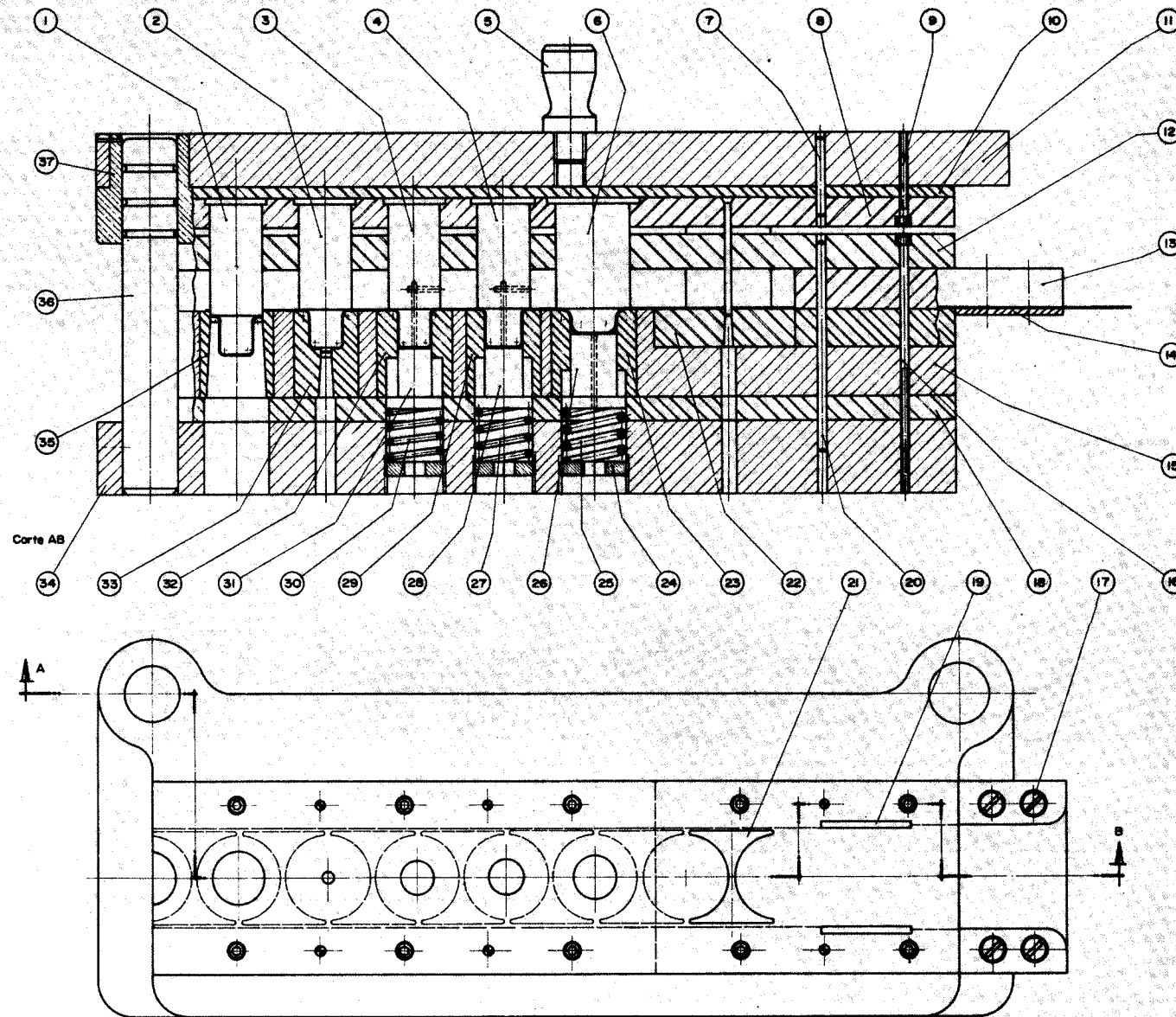

PRODUTO

37	Matriz	2	Bronzo SAE #60
36	Coluna	2	Aço NB 1020
35	Matriz (reacor. bot.)	1	Aço RCC
34	Busa inferior	1	Ferro fundido
33	Matriz (furo)	1	Aço RCC
32	Matriz (oculinas)	1	Aço RCC
31	Extrator	1	Aço NB 1010
30	Mola	1	Aço NB 10B5 d = 3
29	Matriz (2º repuxo)	1	Aço RCC
28	Extrator	1	Aço NB 1010
27	Mola	1	Aço NB 10B5 d = 3,5
26	Extrator	1	Aço NB 1010
25	Mola	1	Aço NB 10B5 d = 4
24	Tipão a/lastimbo	3	Aço NB 1010
23	Matriz (1º repuxo)	1	Aço RCC
22	Matriz	1	Aço RCC
21	Fuso guia	1	Aço RCC
20	Pino alfinete	6	Aço preto Ø3/16" x 95
19	Fuso de ajuste	1	Aço RCC
18	Placa de choquete	1	Aço NB 1040
17	Paraf. col. escar.	4	Ø1/4" x 22
16	Paraf. ALLEN	10	Ø3/16" x 95
15	Apelo das matrizes	1	Aço NB 1010
14	Guia fixante	1	Aço NB 1010
13	Guia de chape	1	Aço NB 1010
12	Placa ativadora	1	Aço NB 1020
11	Busa superior	1	Ferro fundido
10	Placa de chape	1	Aço NB 1040
9	Paraf. ALLEN	10	Ø3/16" x 30
8	Paraf. punção	1	Aço NB 1010
7	Pino alfinete	6	Aço preto Ø3/16" x 95
6	Parafuso	1	Aço RCC
5	Exatão	1	Aço NB 1020
4	Parafuso	1	Aço RCC
3	Parafuso	1	Aço RCC
2	Parafuso	1	Aço RCC
1	Parafuso	1	Aço RCC
Nº	DESCRIÇÕES	MATERIAL E DIMENSÕES	

FERRAMENTAS DE CUNHA

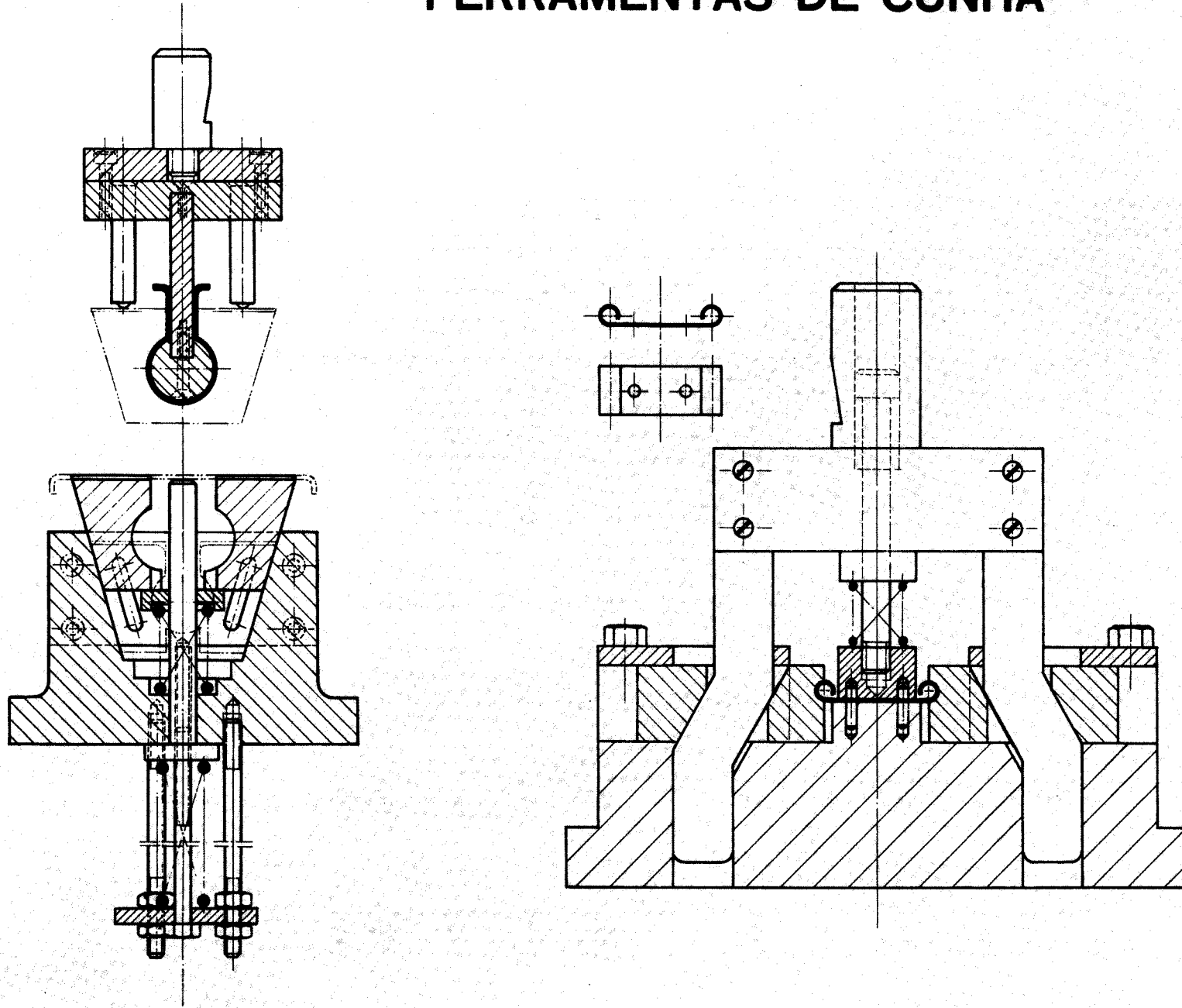

FERRAMENTA PARA FURAÇÃO RADIAL

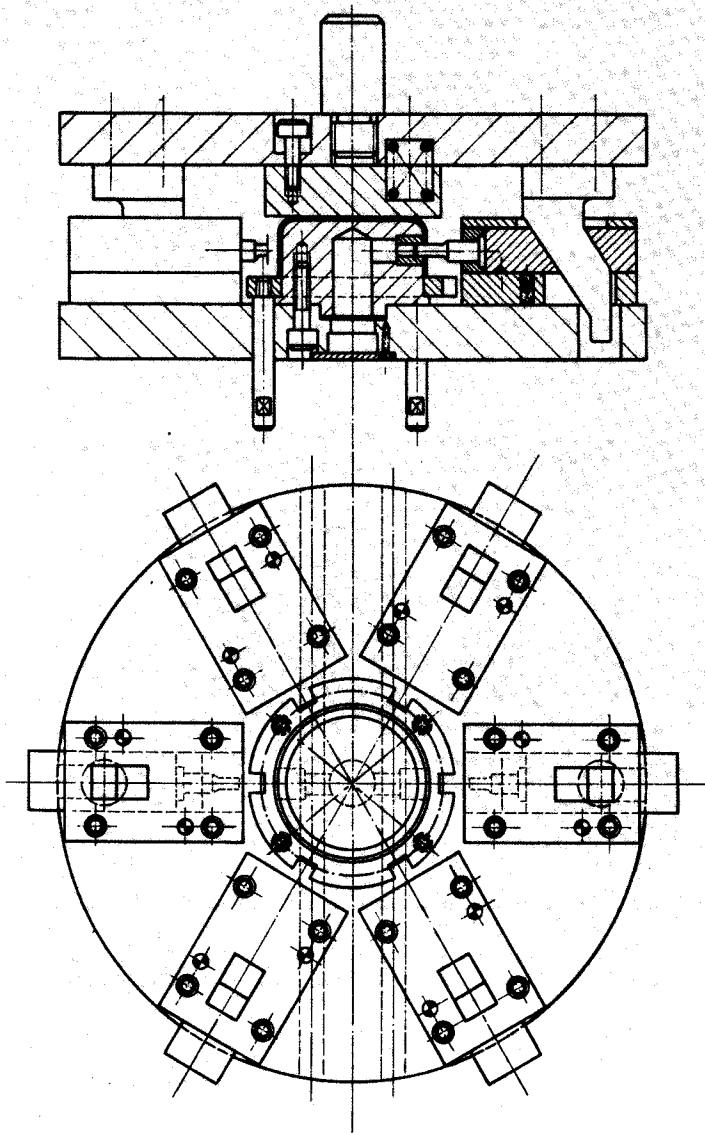

FERRAMENTA PARA FURAÇÃO E DOBRA LATERAL

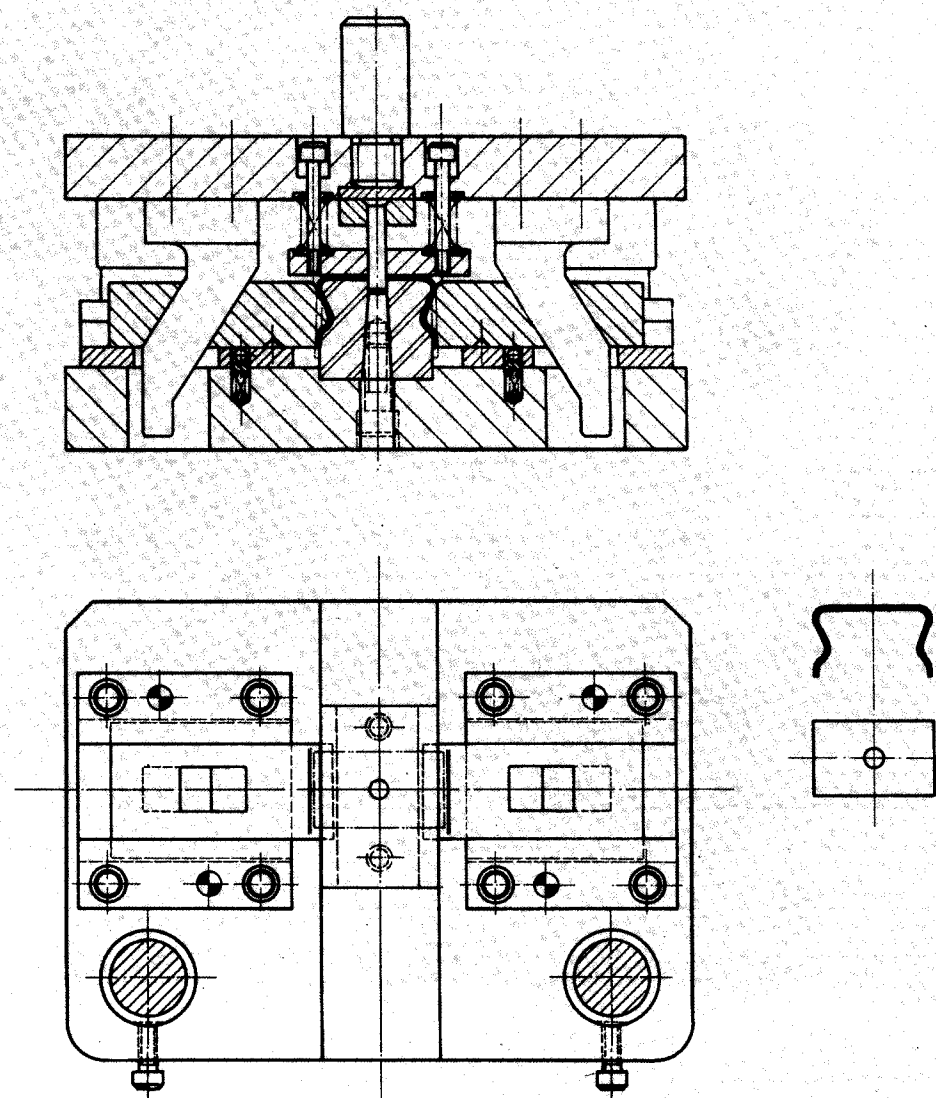

FERRAMENTAS DE DOBRA COM PUNÇÃO OSCILANTE

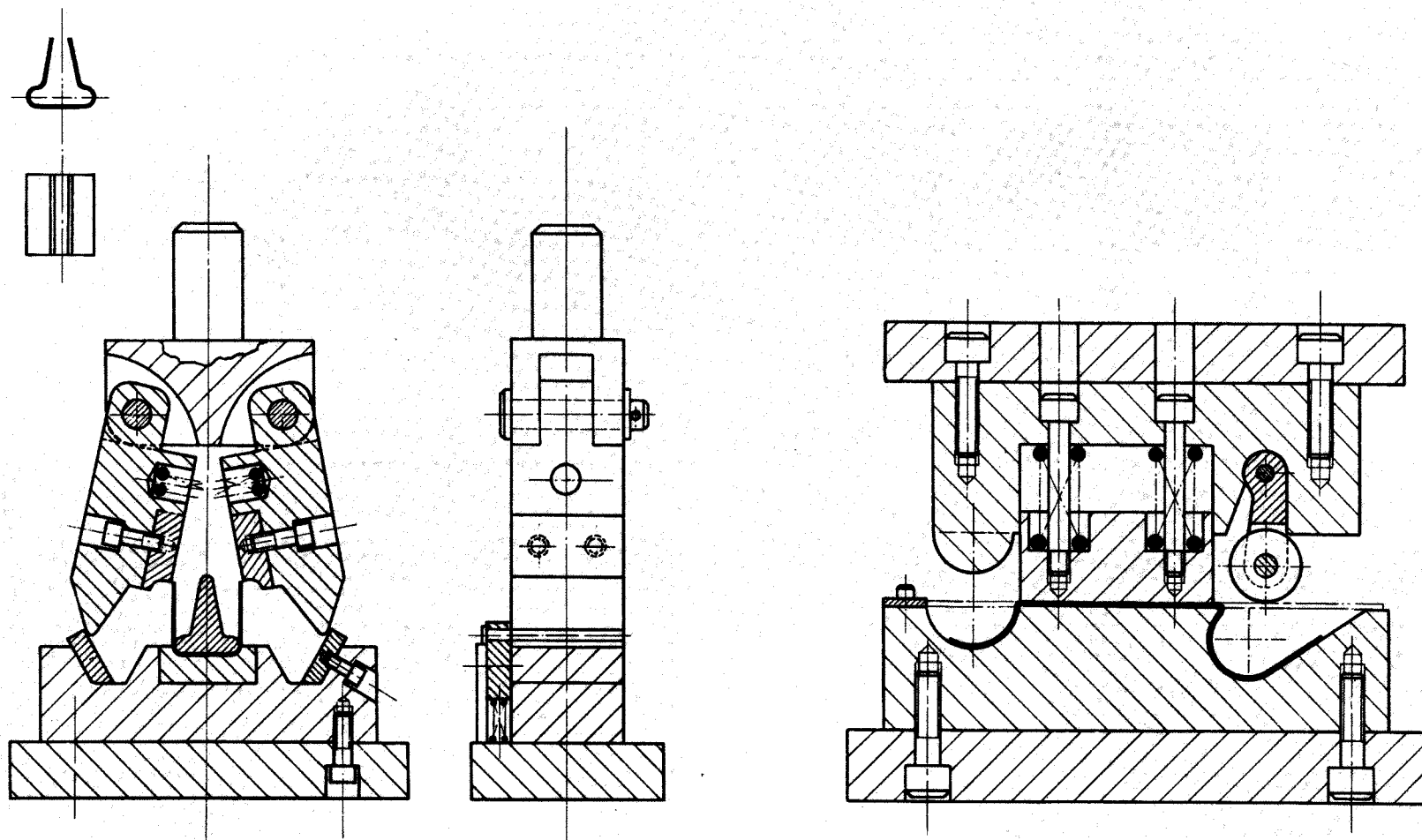

ALIMENTADOR

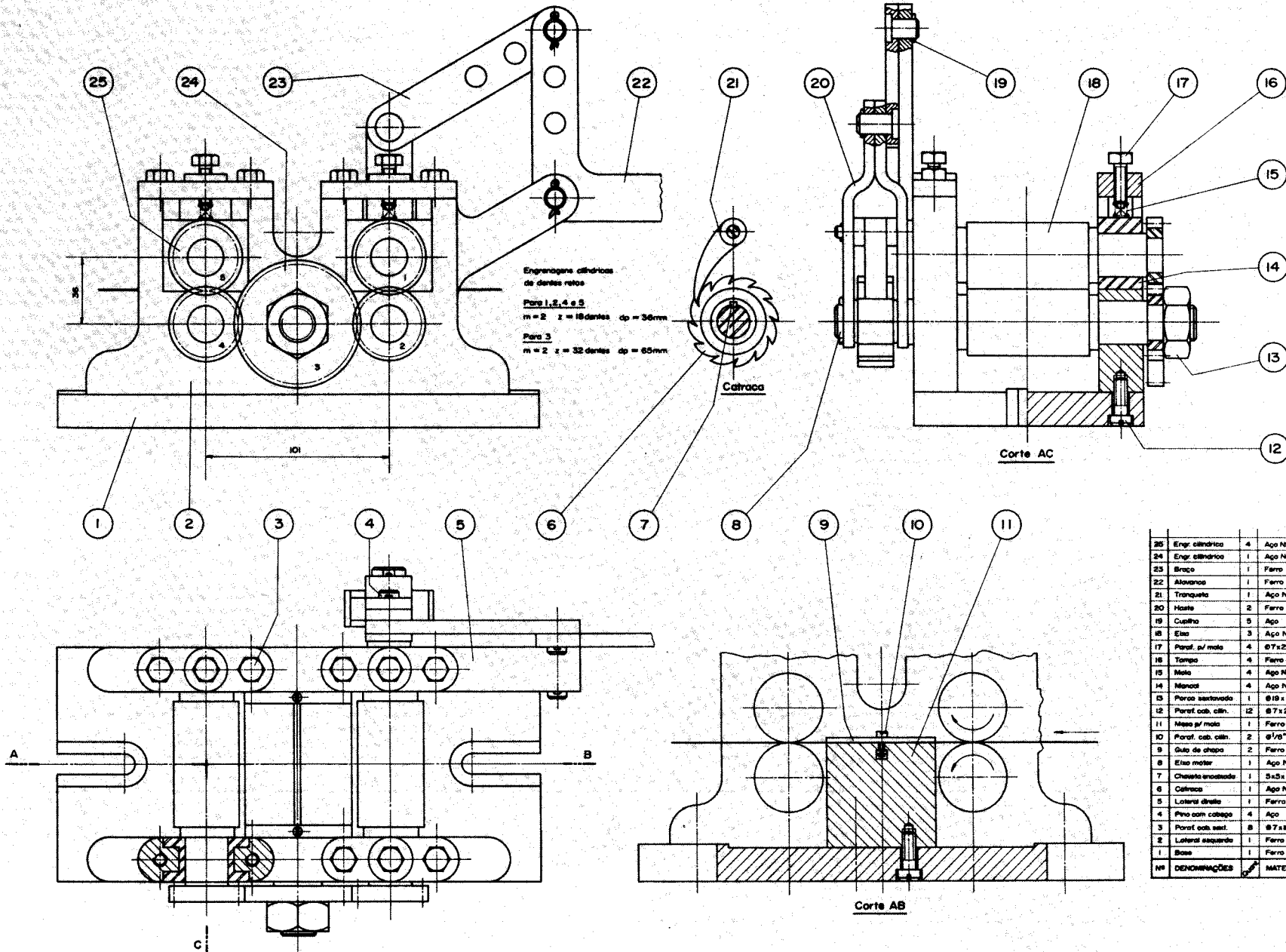

25	Engr. cilíndrica	4	Aço NB 1040
24	Engr. cilíndrica	1	Aço NB 1040
23	Braco	1	Ferro
22	Alavanca	1	Ferro
21	Tranqueta	1	Aço NB 1020
20	Haste	2	Ferro
19	Cupilha	5	Aço
18	Eixo	3	Aço NB 1020
17	Paraf. p/ mofo	4	Ø 7 x 25
16	Tampa	4	Ferro fundido
15	Mola	4	Aço NB p/ mola
14	Mancal	4	Aço NB 1020
13	Paraf. acastorado	1	Ø 18 x 15
12	Paraf. cob. cilin.	12	Ø 7 x 20
11	Mesa p/ mola	1	Ferro fundido
10	Paraf. cob. cilin.	2	Ø 1/8" x 10,5
9	Gua de chapão	2	Ferro
8	Eixo motor	1	Aço NB 1020
7	Chaveta anelada	1	5x5 x 24
6	Catraca	1	Aço NB 1020
5	Lateral direita	1	Ferro fundido
4	Pino com cotopelo	4	Aço
3	Paraf. cob. sext.	8	Ø 7 x 18
2	Lateral esquerda	1	Ferro fundido
1	Base	1	Ferro fundido
Nº	DENOMINAÇÕES		MATERIAL E DIMENSÕES

MOLDE PARA PLÁSTICO

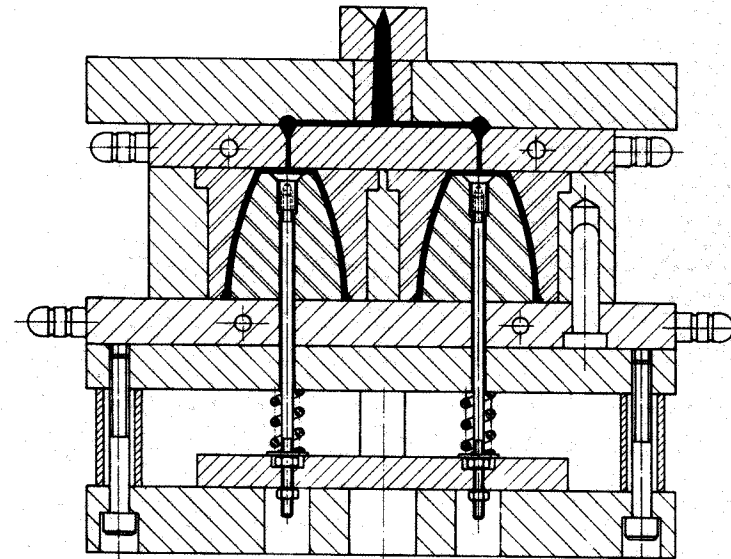
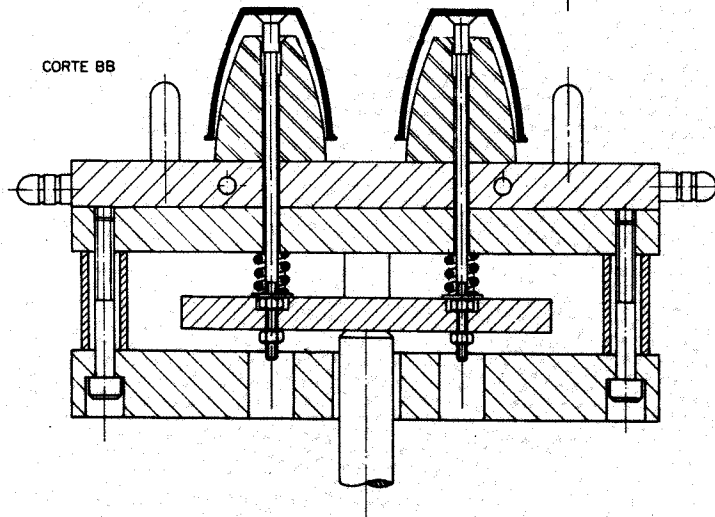
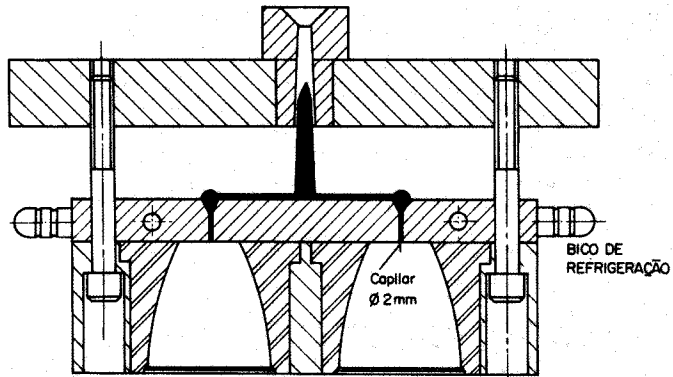
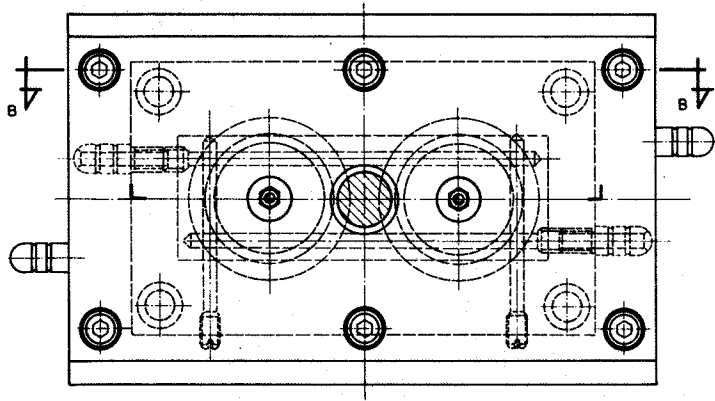

CORTE AA

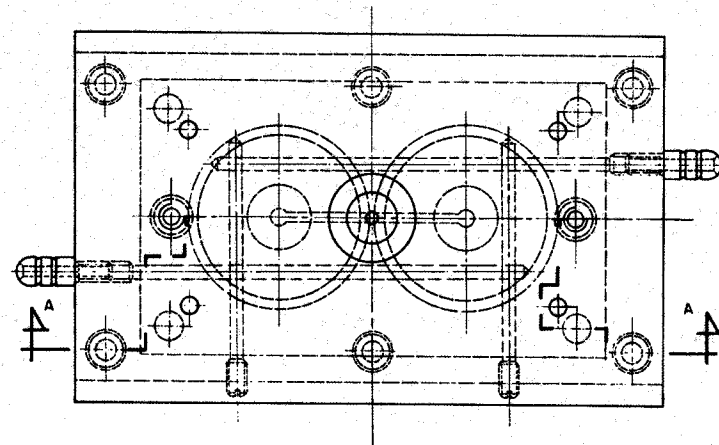

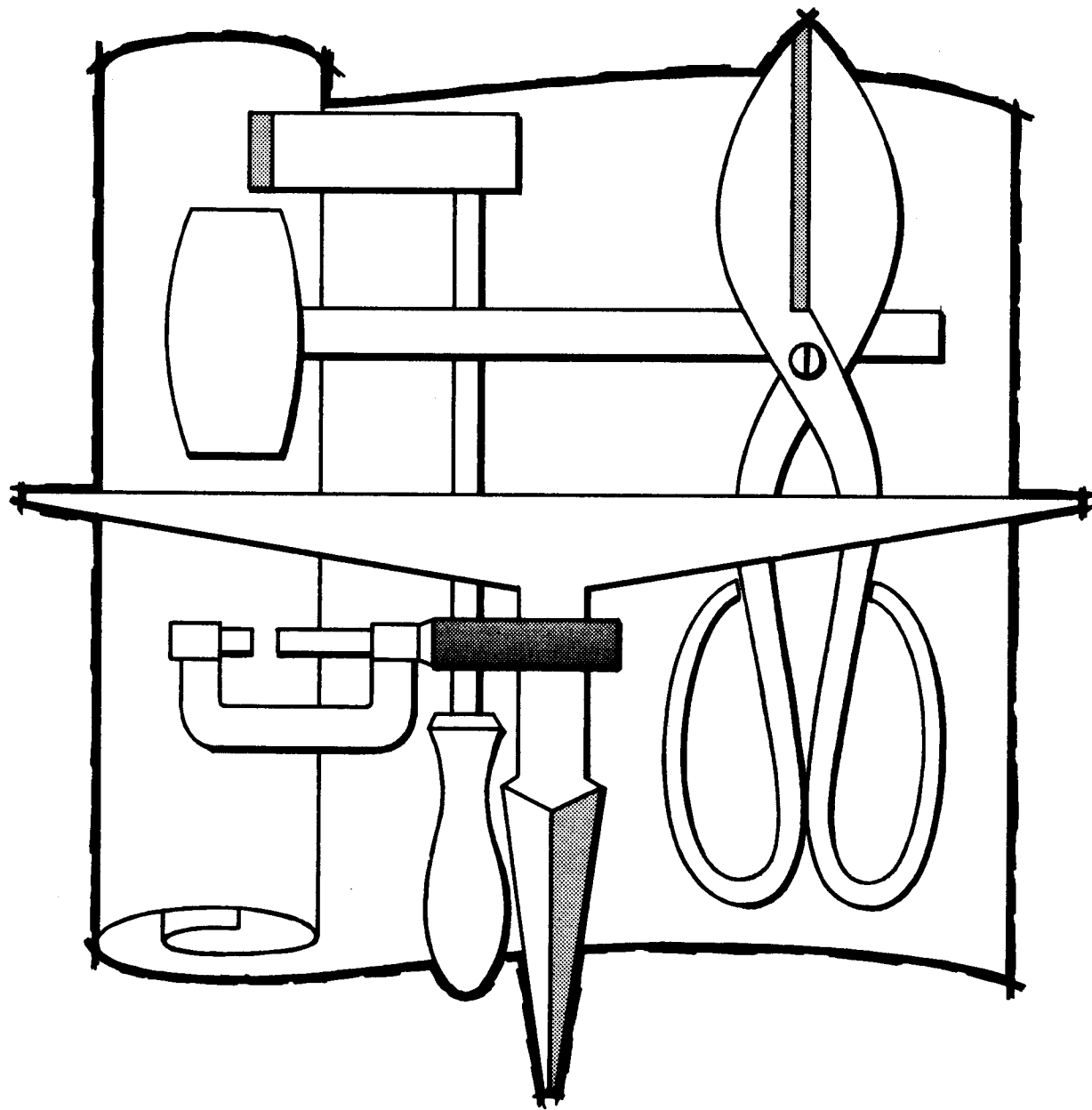

8 funilaria e caldeiraria

intersecções de
sólidos e
planificação
de superfícies

CHAPAS:

ARREMATES EMENDAS

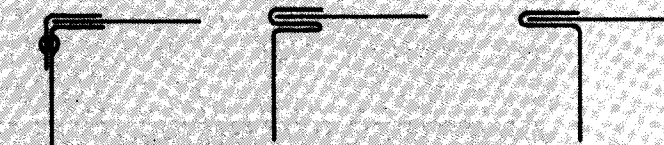
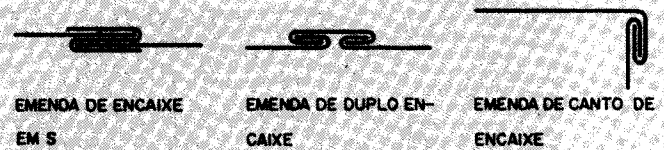
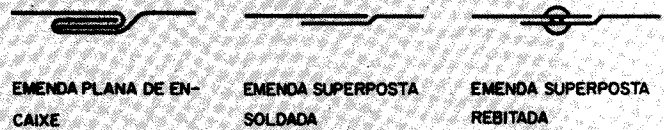
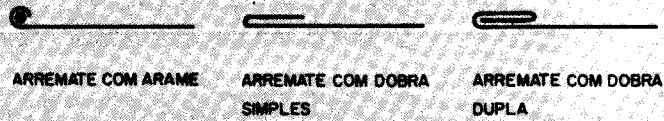

EMENDAS PARA ABERTURAS LATERAIS

DESENVOLVIMENTOS

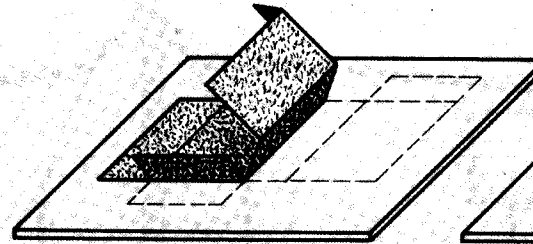

PRISMA

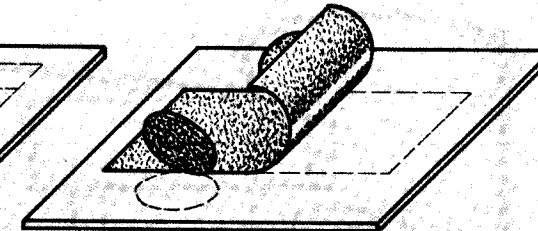

CILINDRO

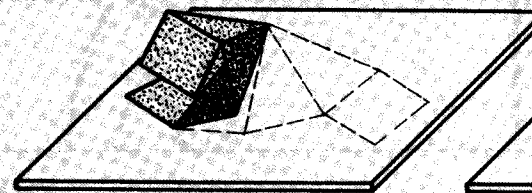

PIRÂMIDE

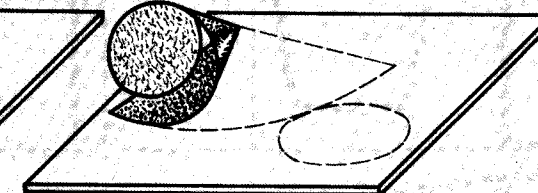

CONE

INTERSECÇÃO

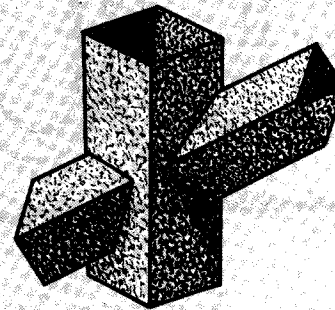

PRISMAS

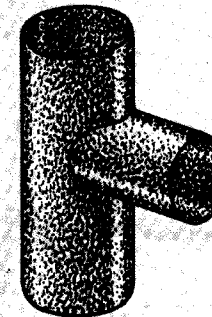

CILINDROS

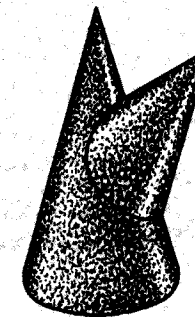

CONES

PRISMA RETO DE SECÇÃO RETANGULAR

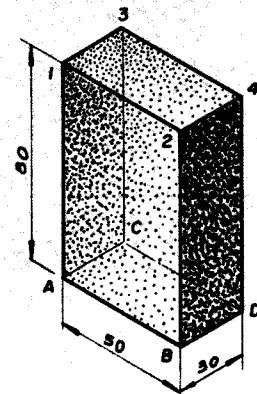
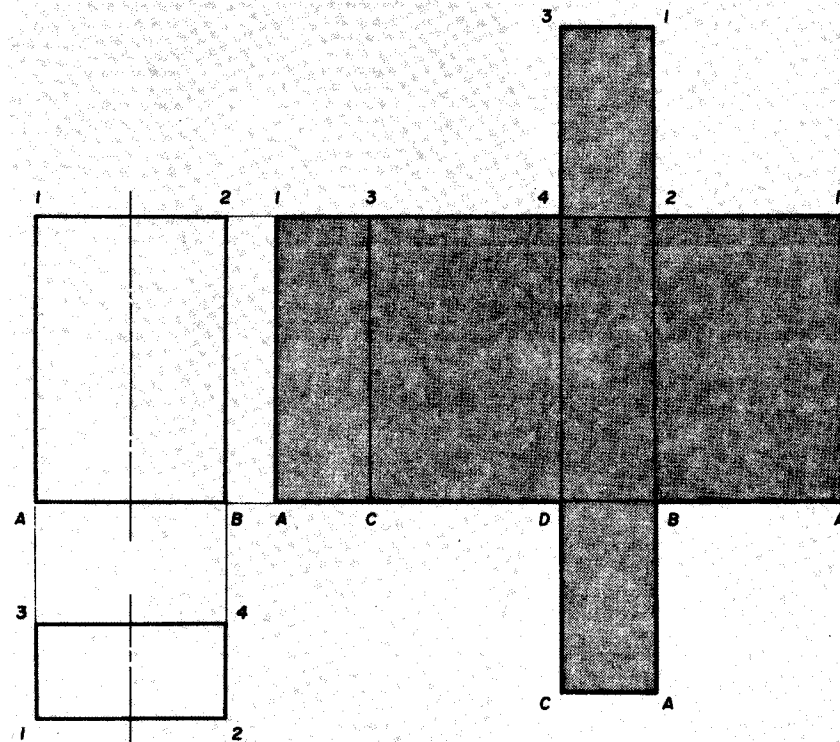

TRONCO DE PRISMA RETO DE SECÇÃO RETANGULAR

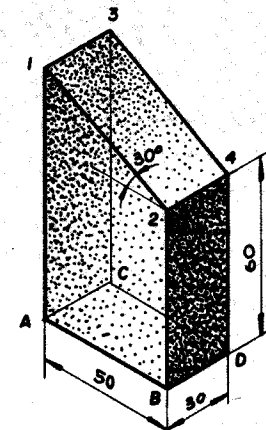
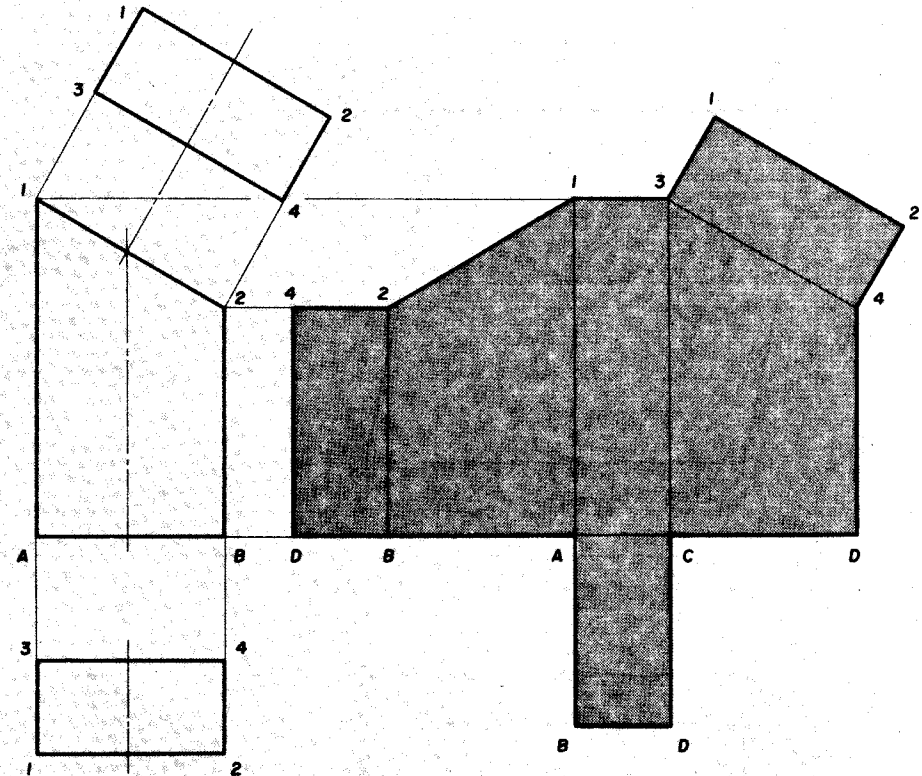

PRISMA INCLINADO DE BASE RETANGULAR

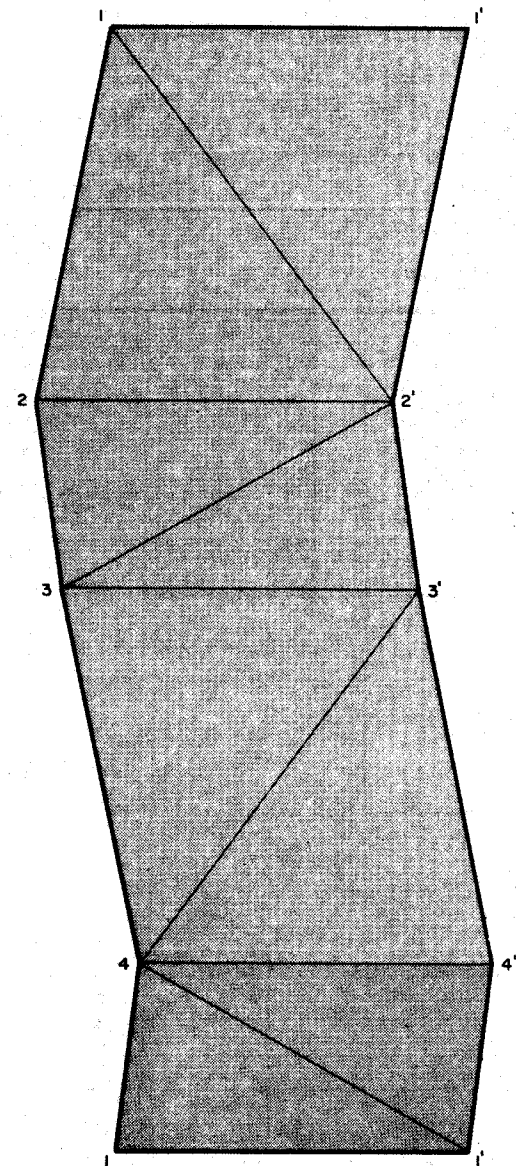
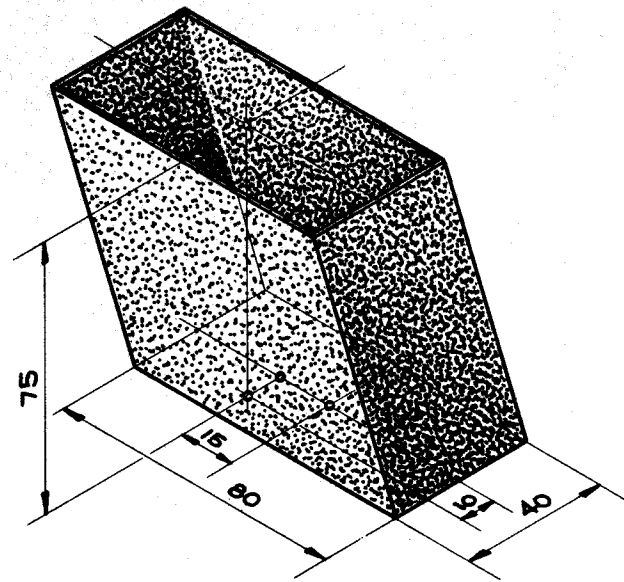
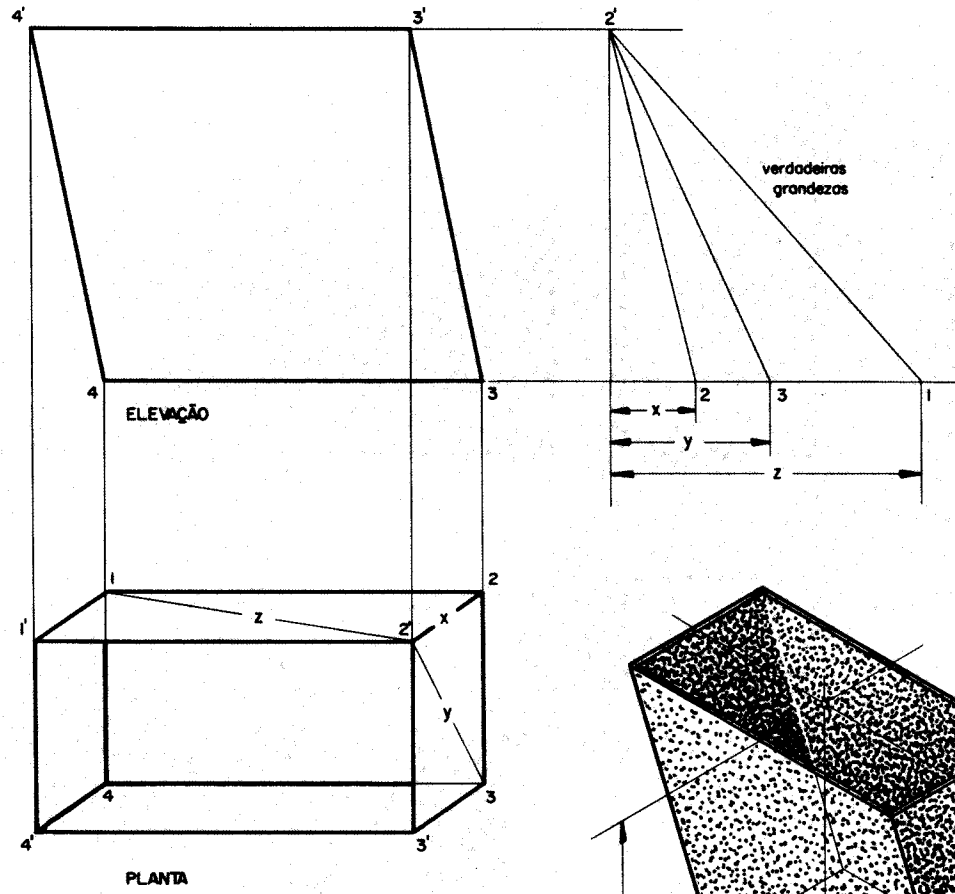

CLINDRO RETO

TRONCO DE CILINDRO RETO

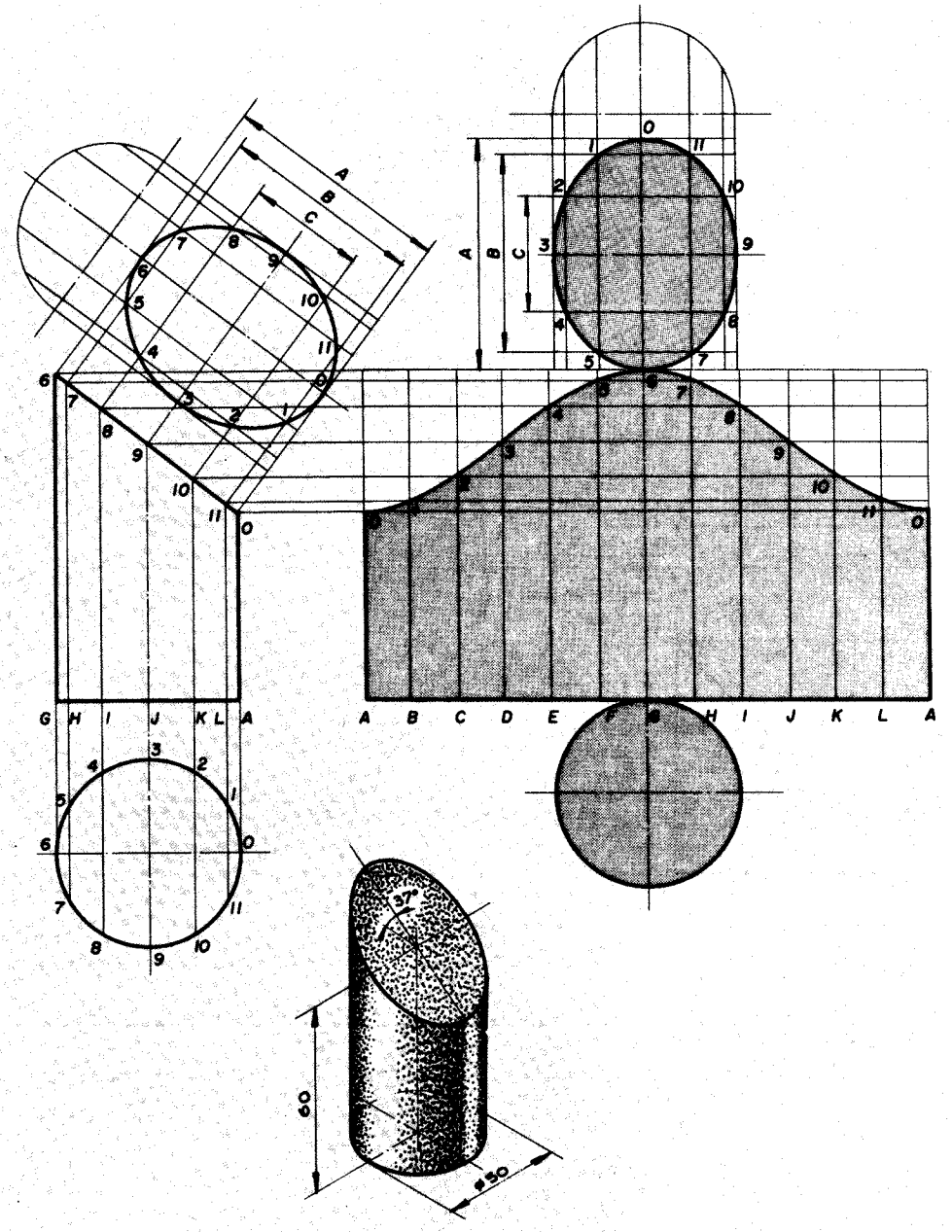
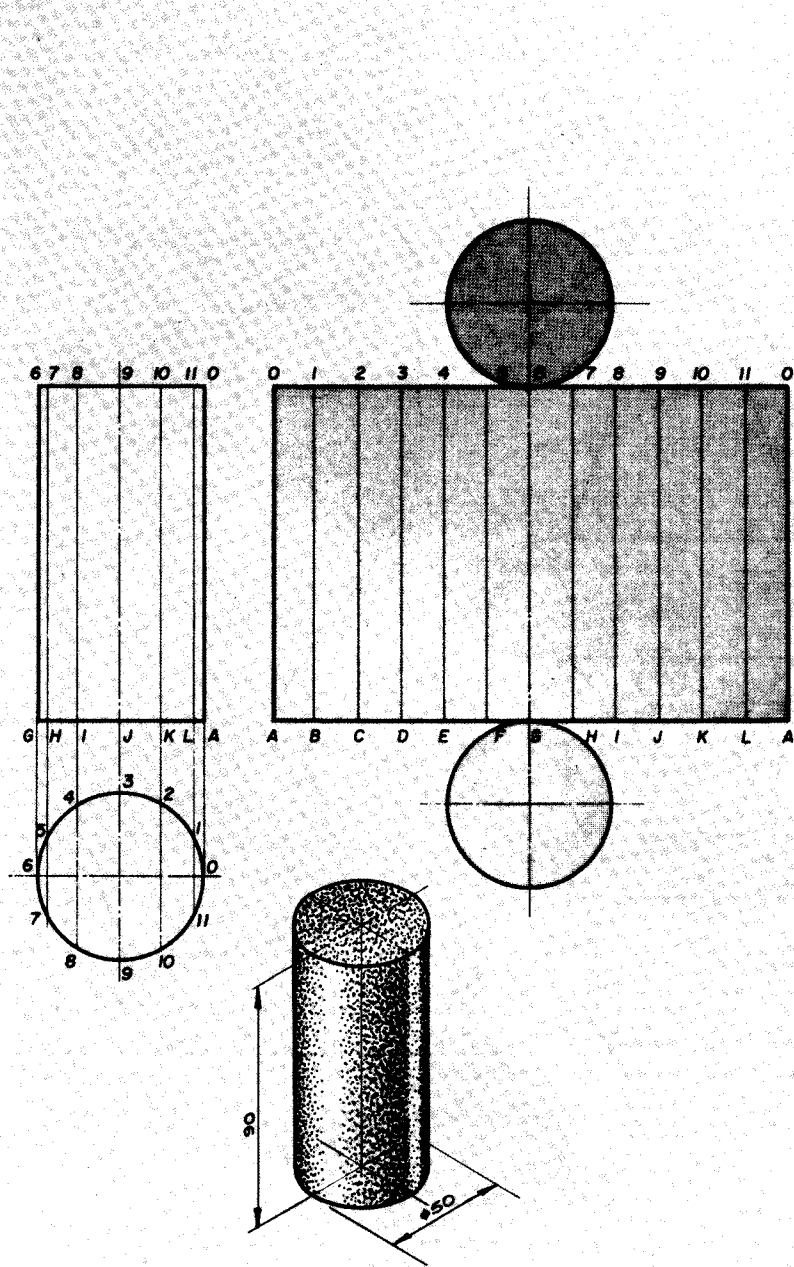

PIRÂMIDE RETA DE BASE QUADRADA

TRONCO DE PIRÂMIDE RETA DE BASE QUADRADA

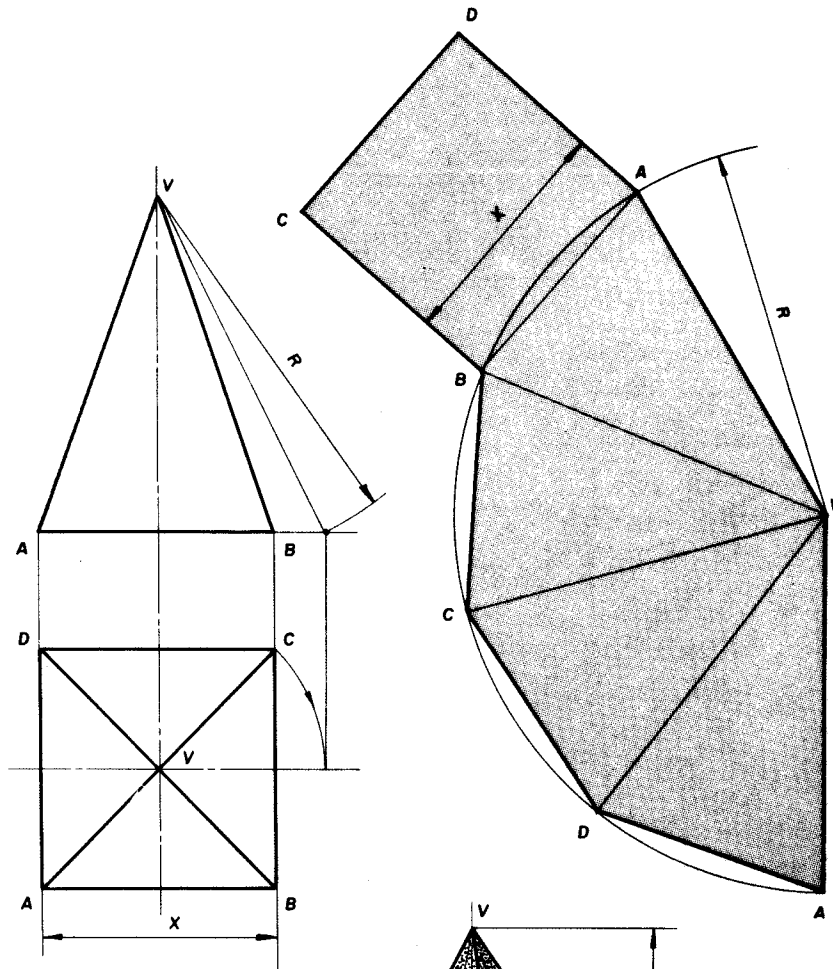

R = verdadeira grandeza da aresta

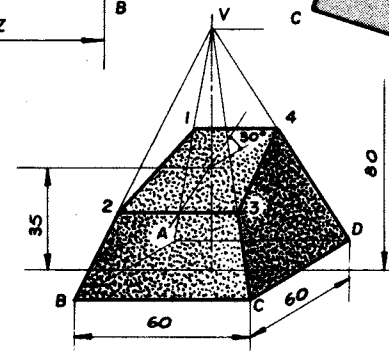
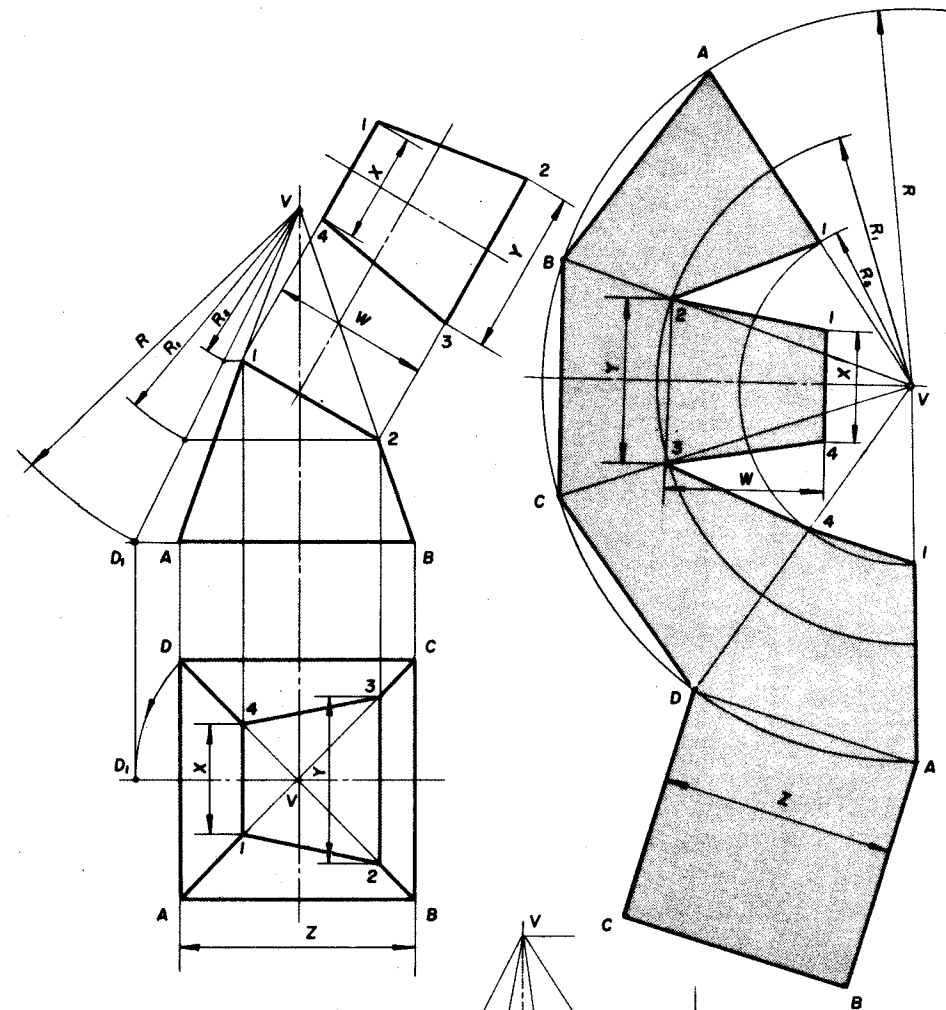
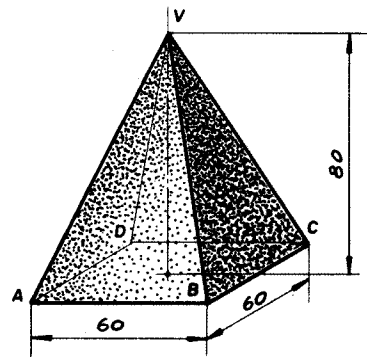

TRONCO DE PIRÂMIDE RETA DE BASE HEXAGONAL

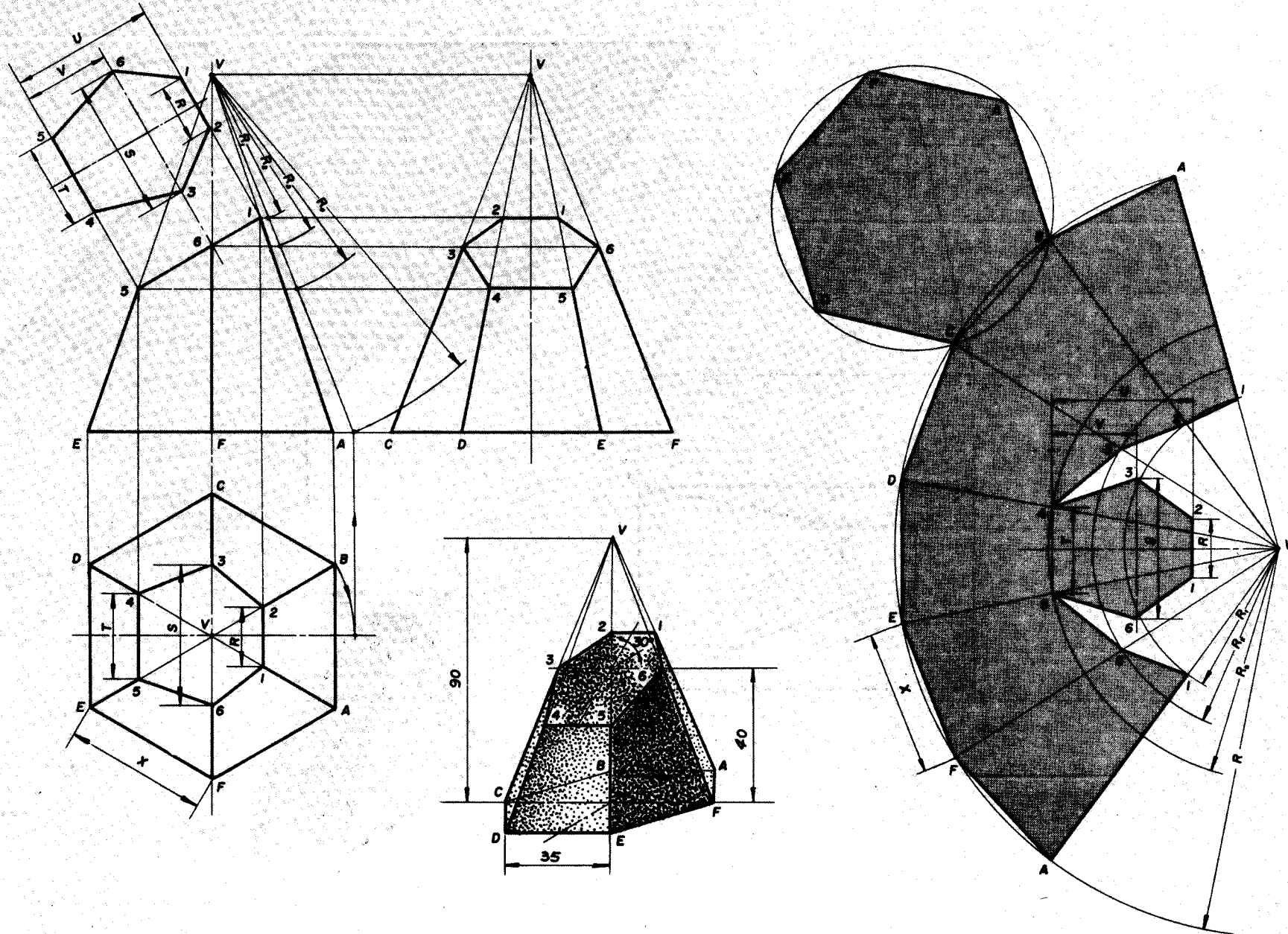

TRONCO DE PIRÂMIDE OBLÍQUA DE BASE RETANGULAR

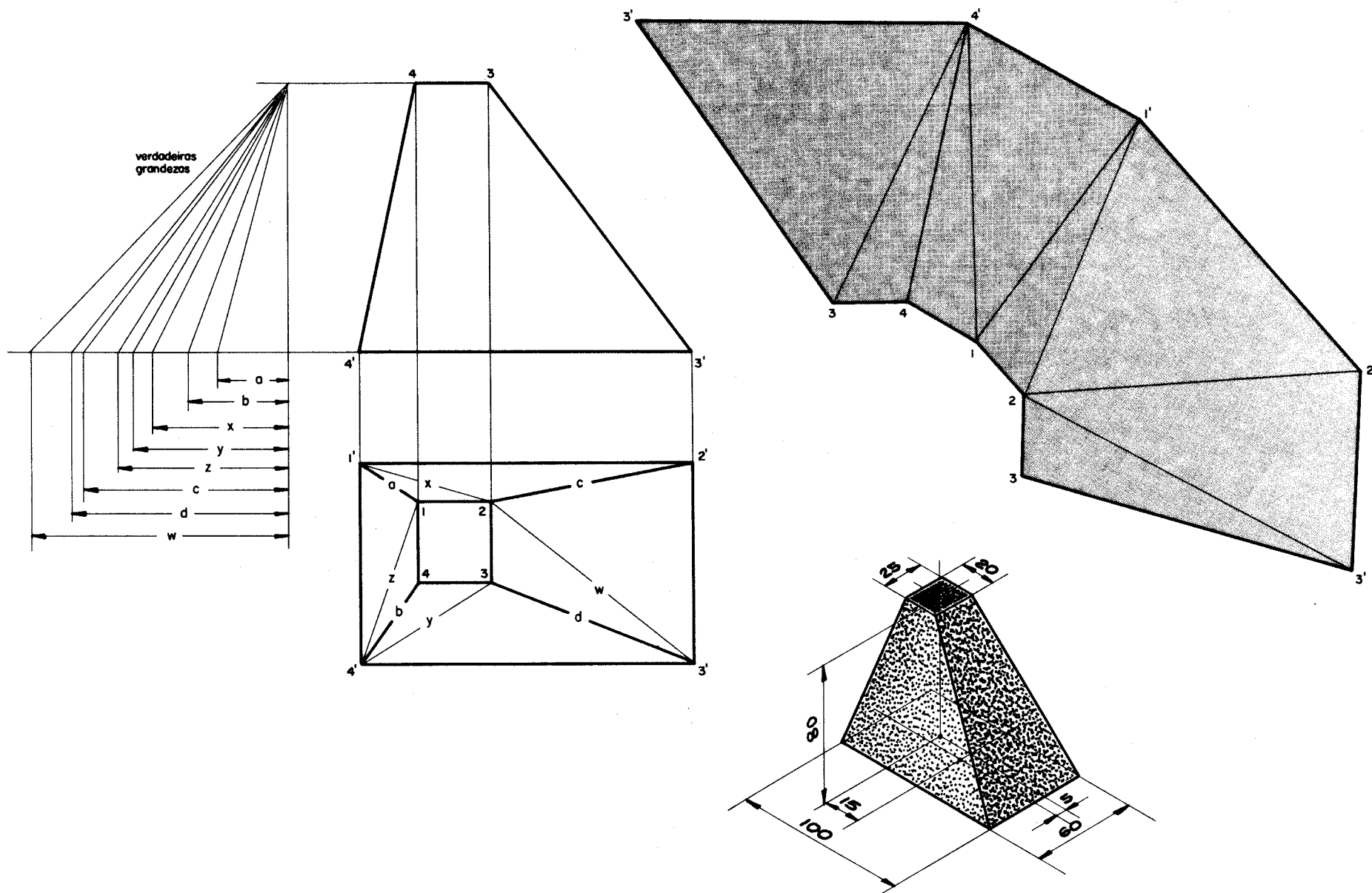

CONE CIRCULAR RETO

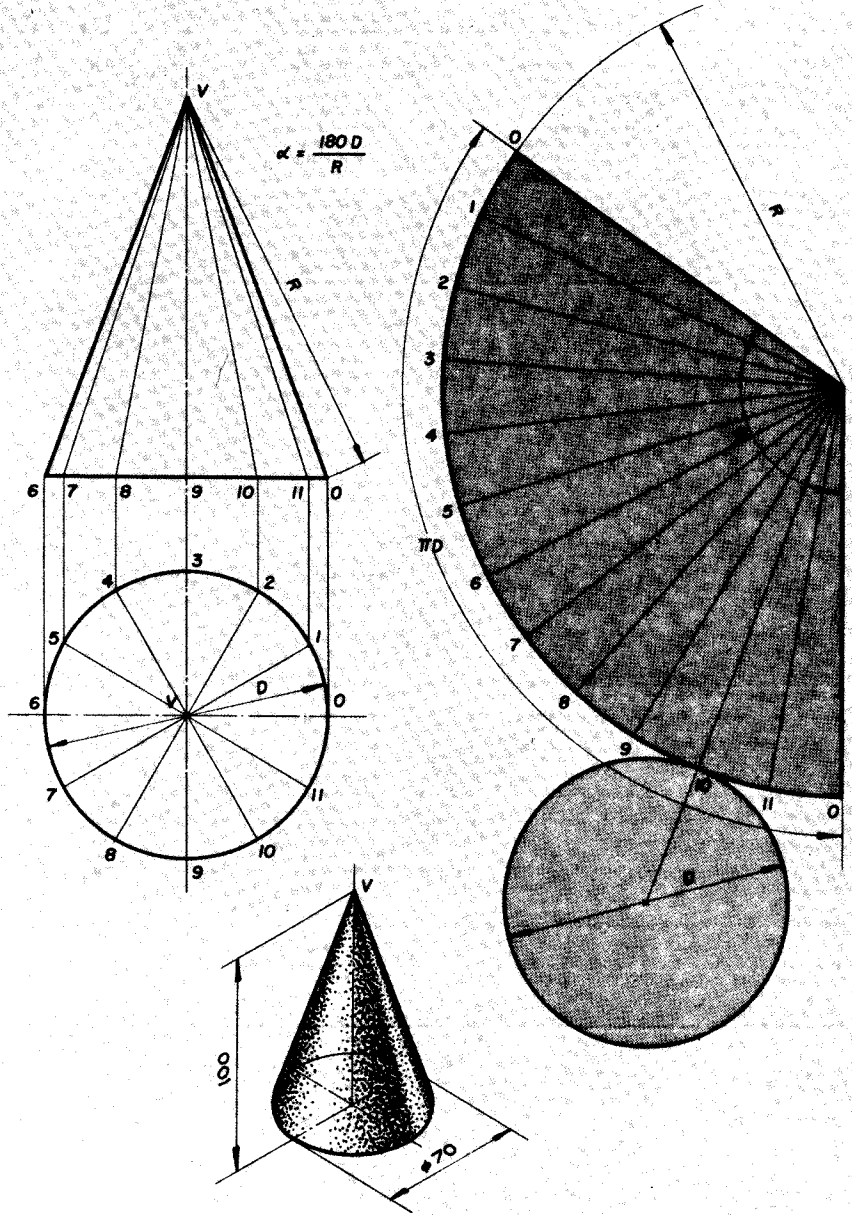

TRONCO DE CONE CIRCULAR RETO

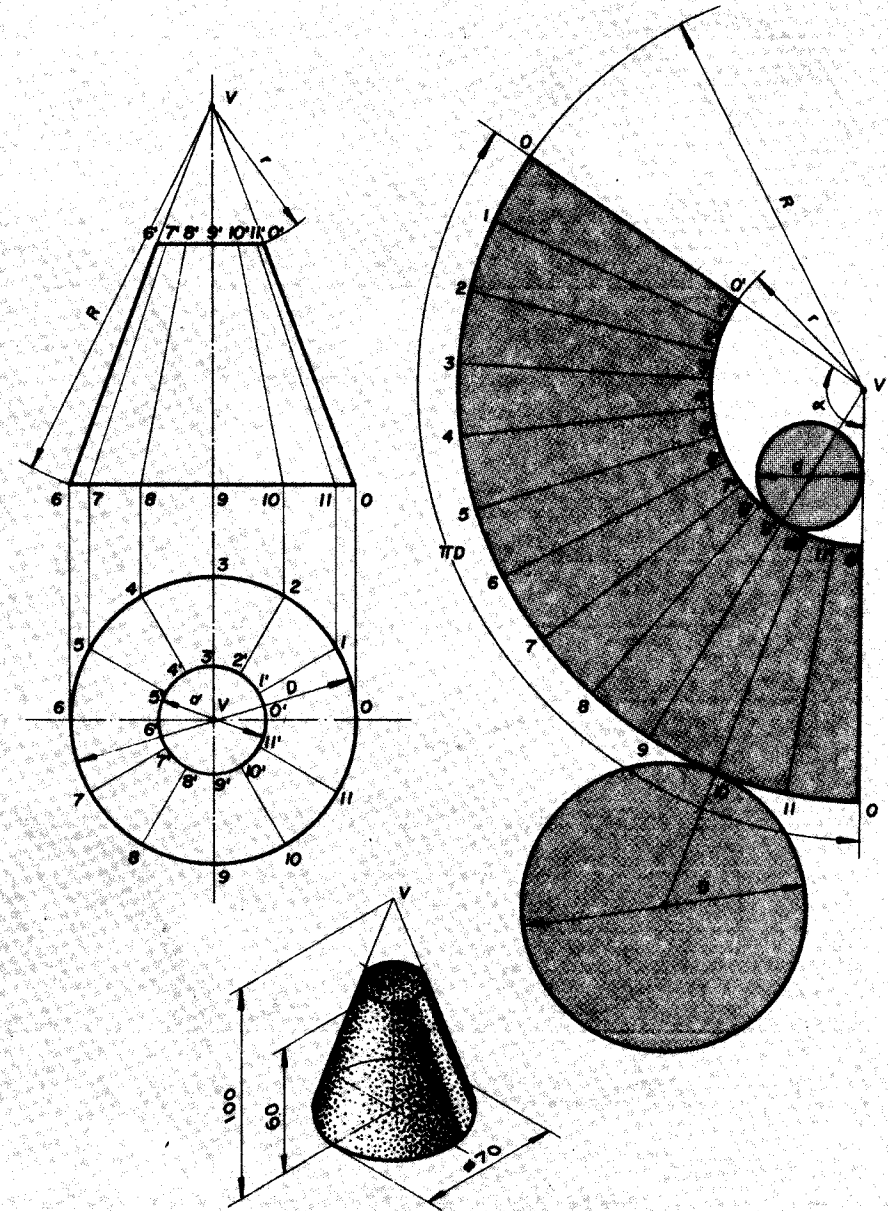

TRONCO DE CONE CIRCULAR RETO COM BASE SUPERIOR OBLÍQUA

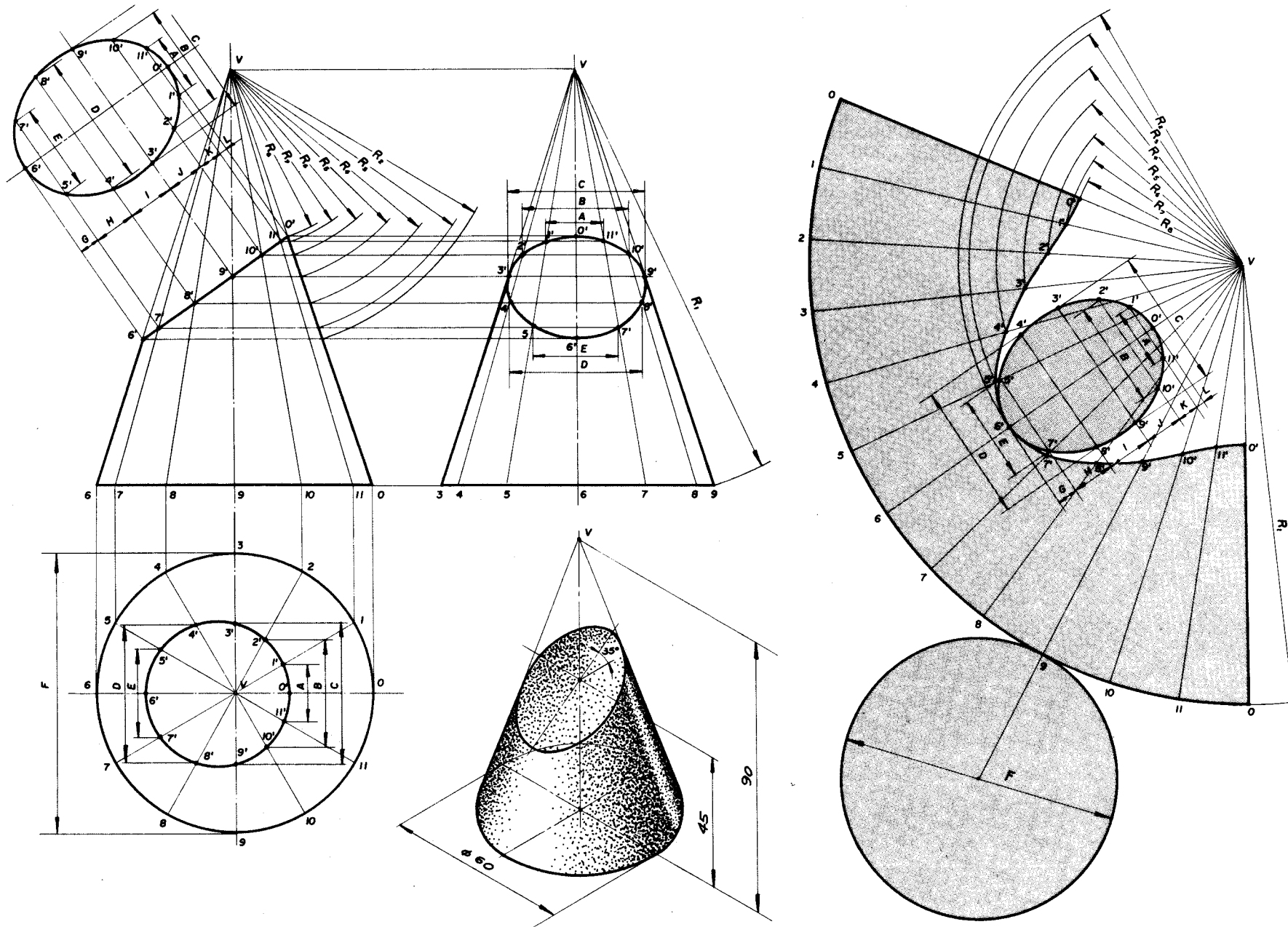

TRONCO DE CONE CIRCULAR RETO COM BASE INFERIOR OBLÍQUA

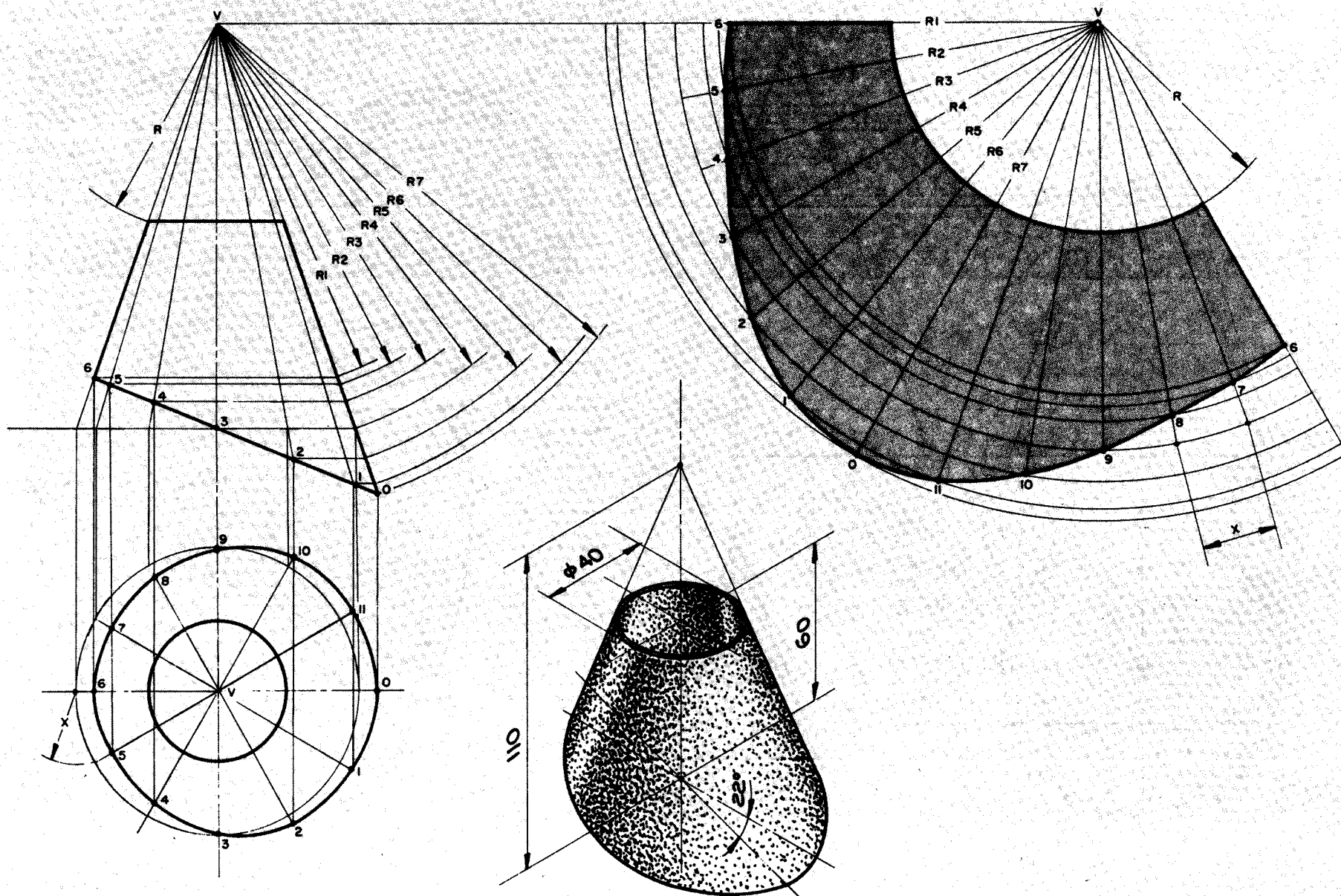

CONE CIRCULAR RETO SECCIONADO PARALELAMENTE AO EIXO

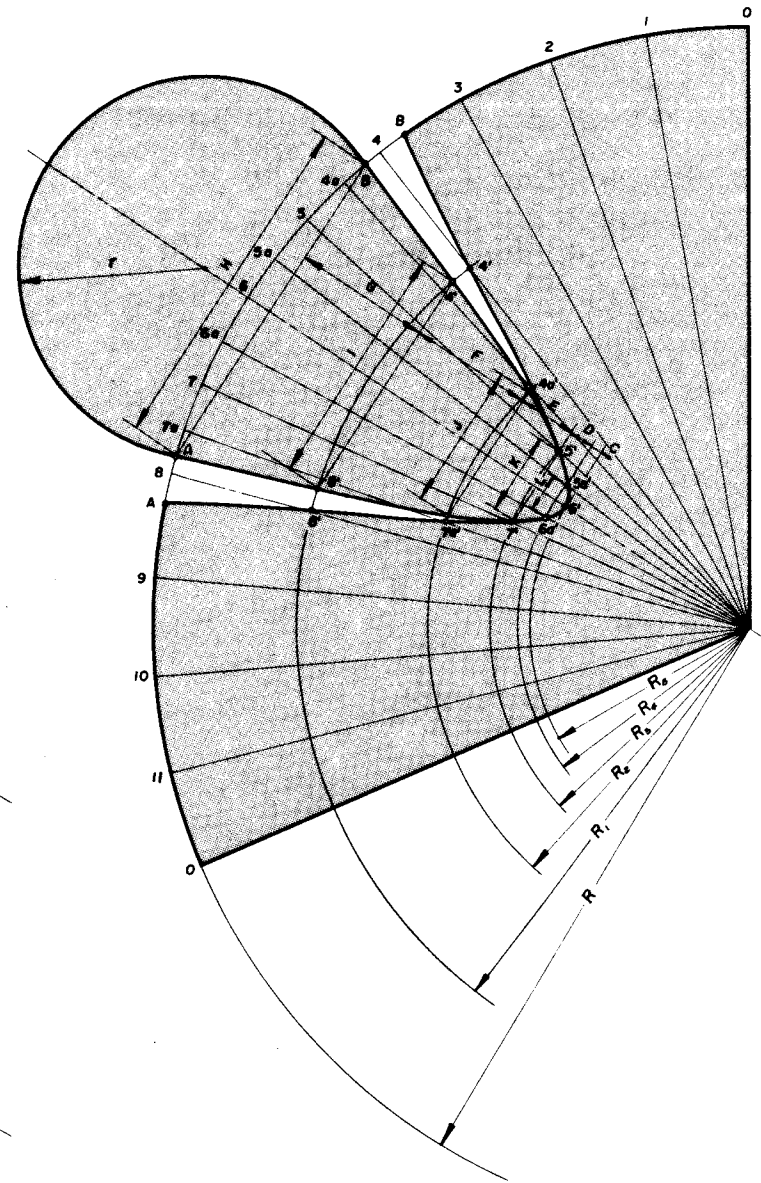
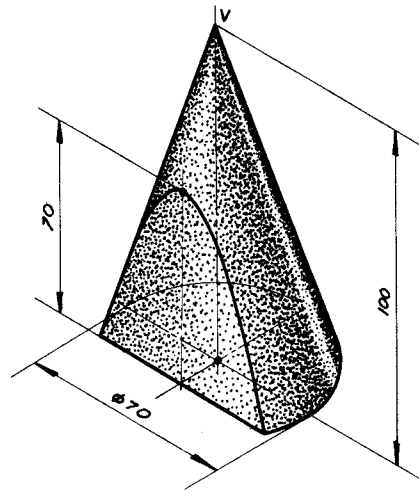
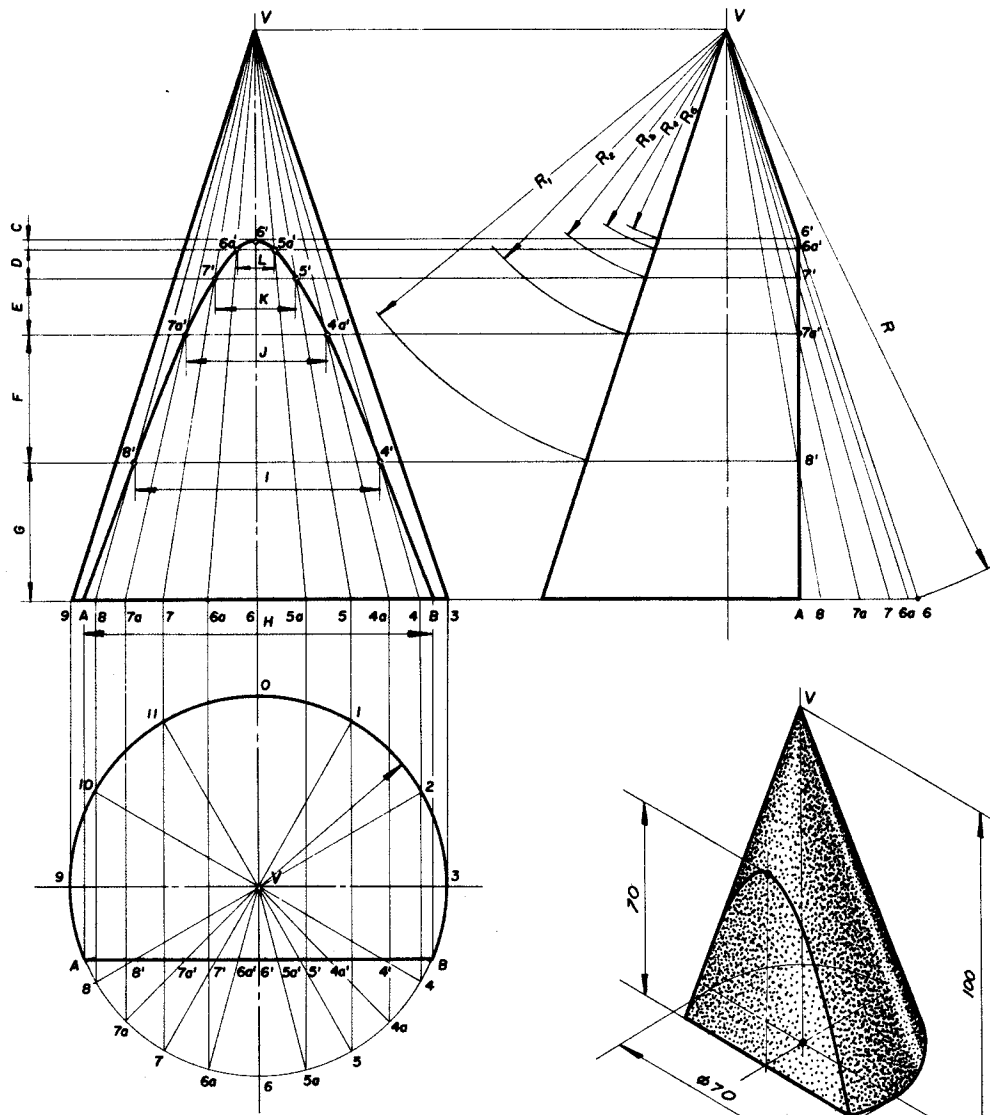

CONE CIRCULAR RETO SECCIONADO PELO VÉRTICE

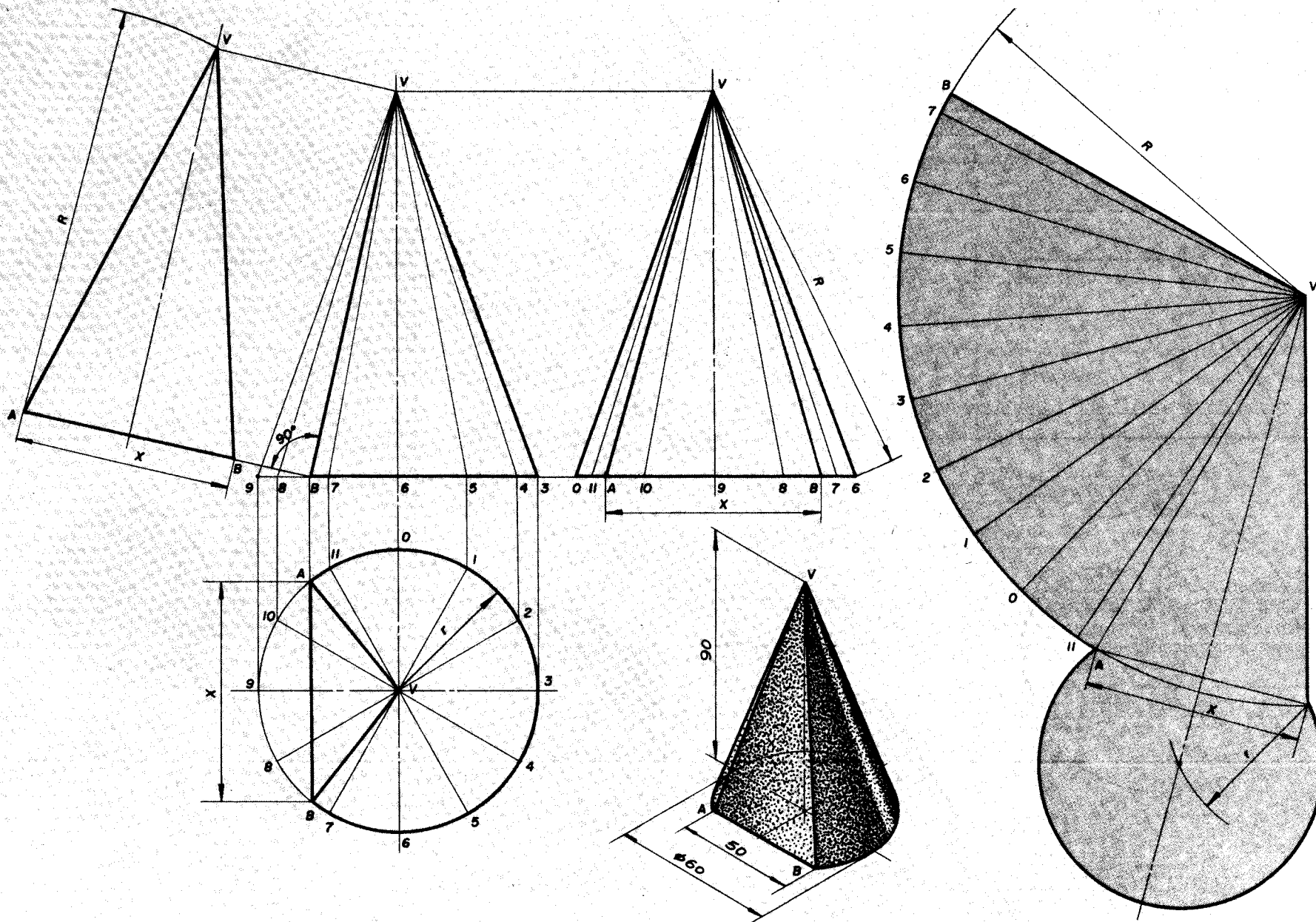

TRONCO DE CONE CIRCULAR OBLÍQUO I

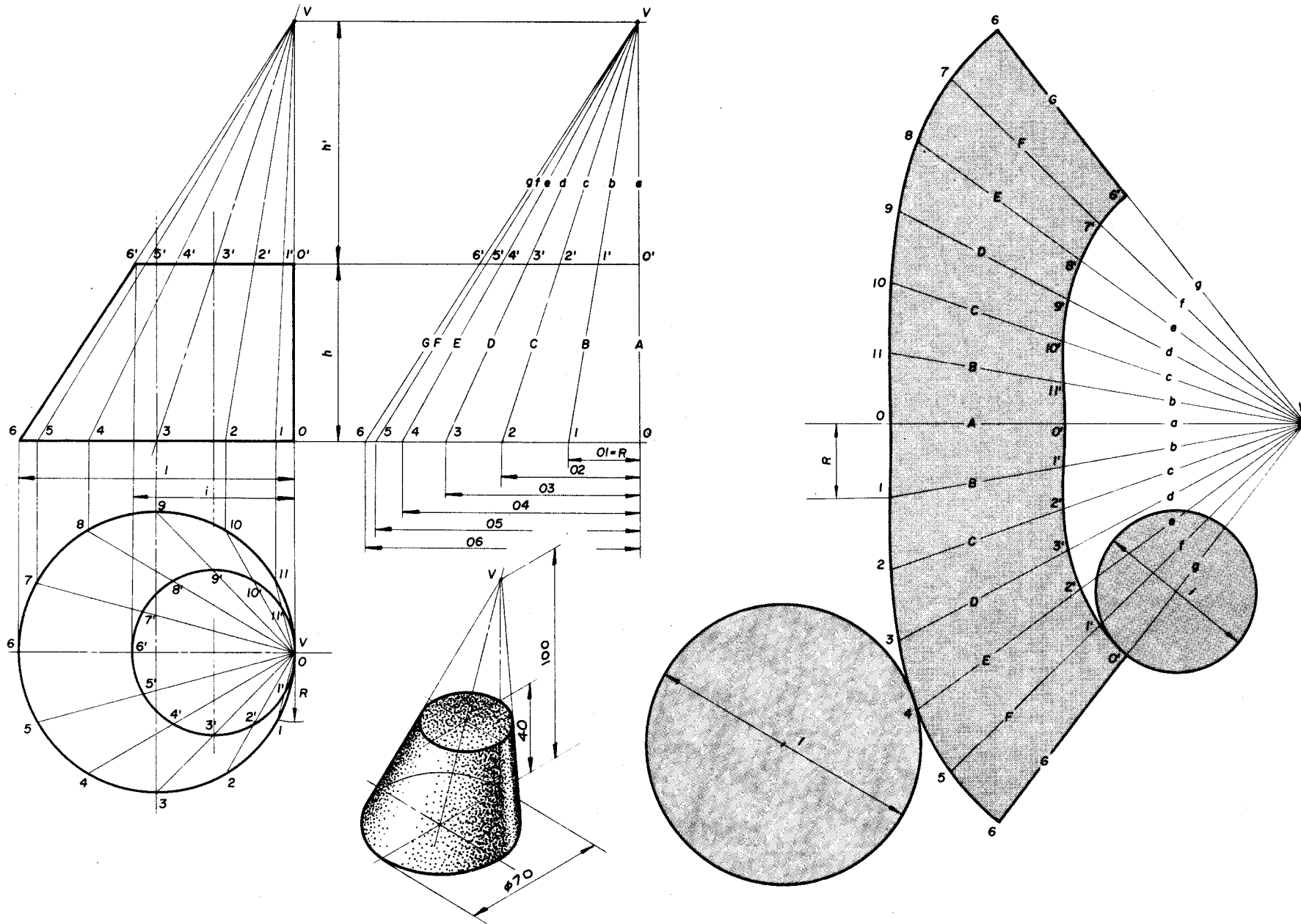

TRONCO DE CONE CIRCULAR OBLÍQUO II

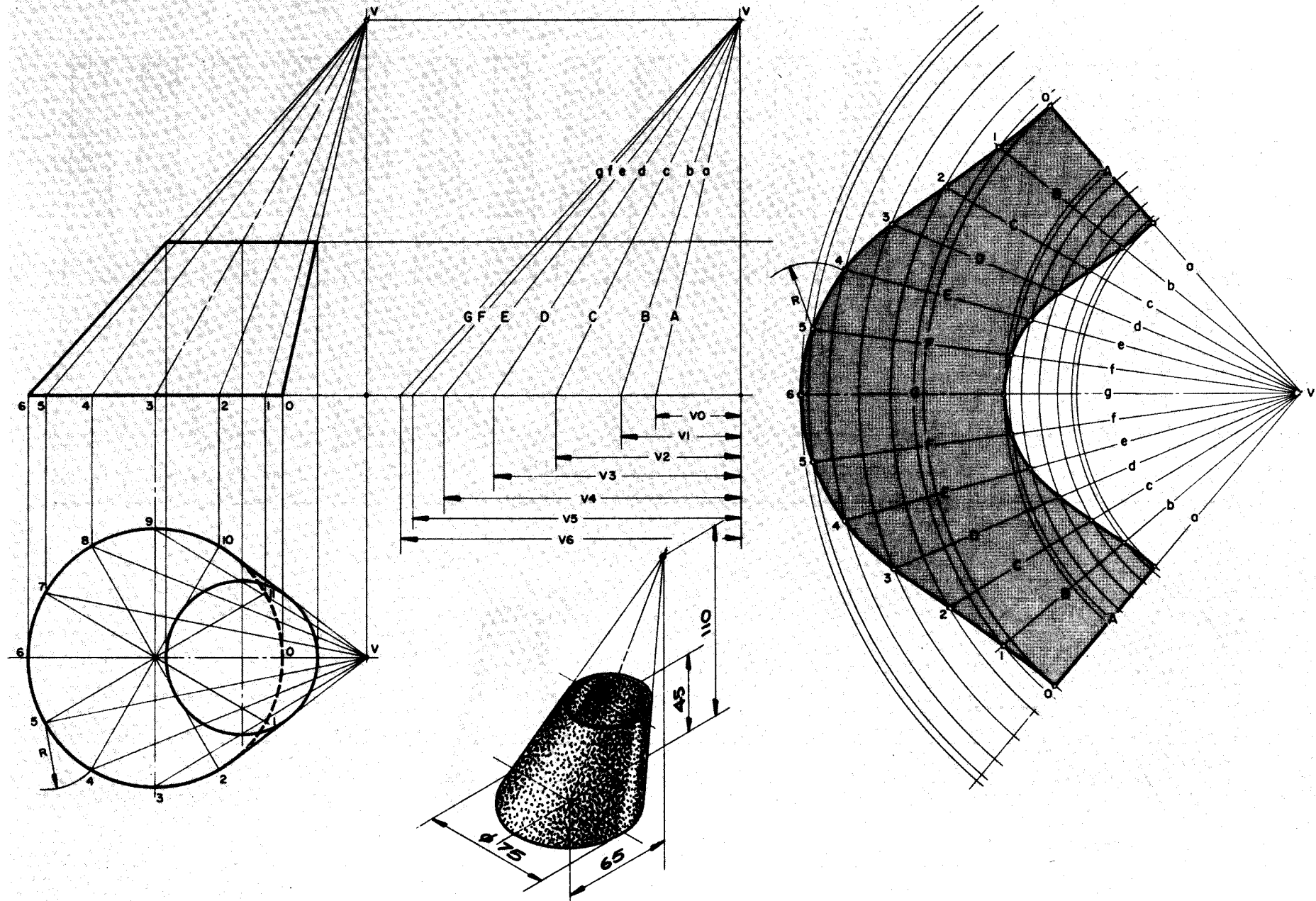

REDUÇÃO CONCÊNTRICA DE DUTO REDONDO PARA REDONDO

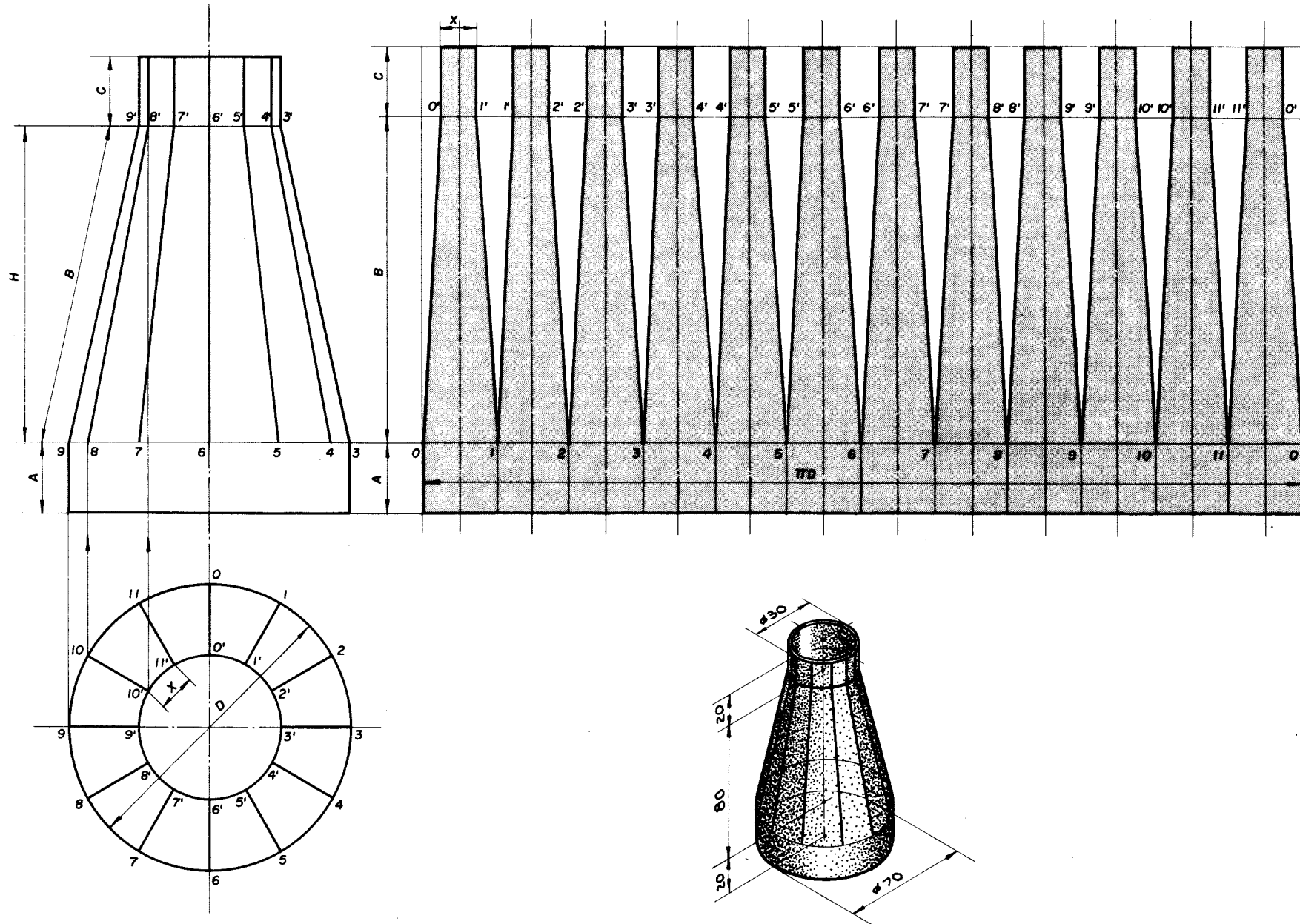

REDUÇÃO EXCÊNTRICA DE DUTO REDONDO PARA REDONDO

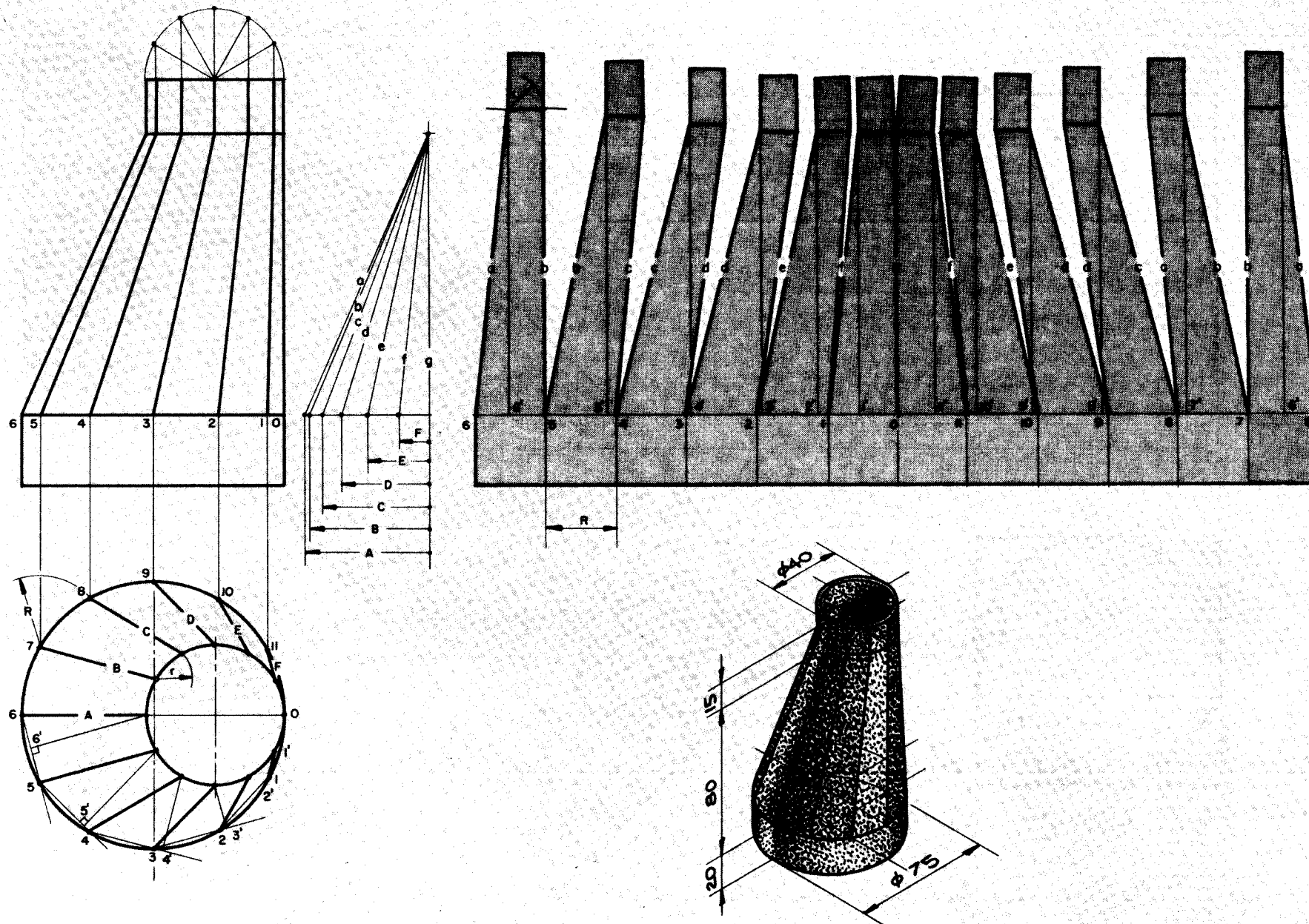

TRANSIÇÃO DE DUTO QUADRADO PARA REDONDO

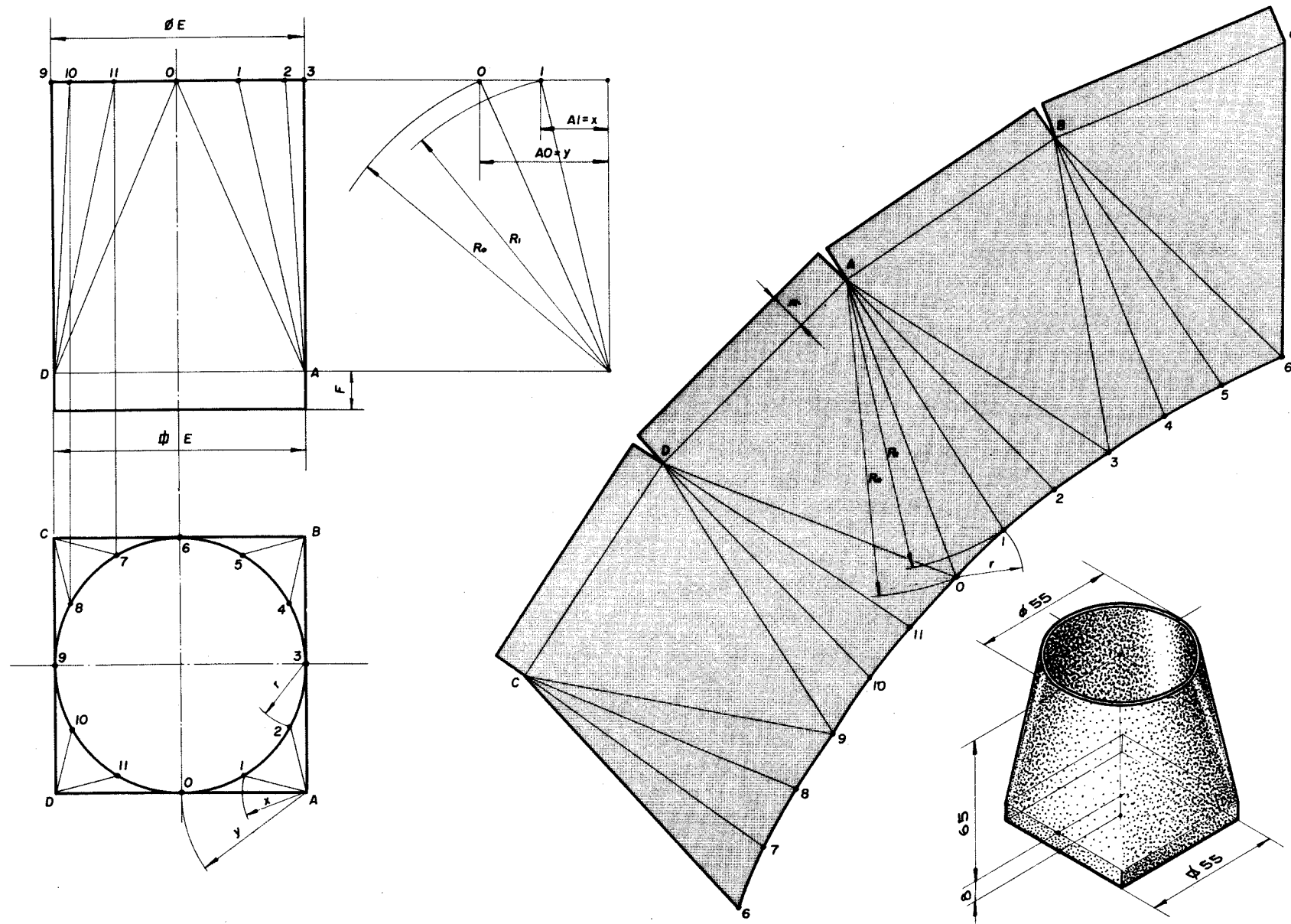

TRANSIÇÃO COM REDUÇÃO CONCÊNTRICA DE DUTO RETANGULAR PARA REDONDO

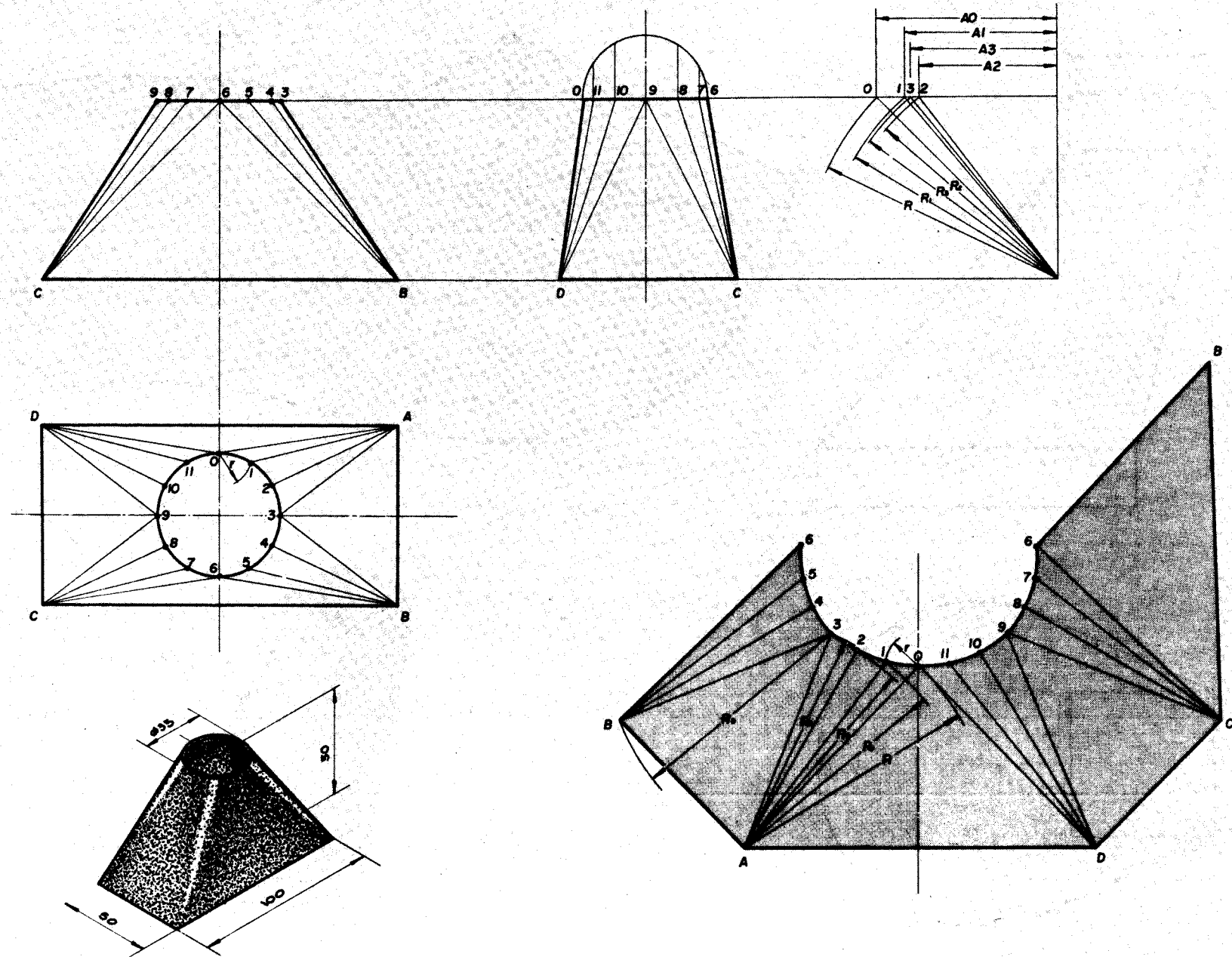

TRANSIÇÃO COM REDUÇÃO DE DUTO REDONDO PARA QUADRADO COM DESVIO PARALELO

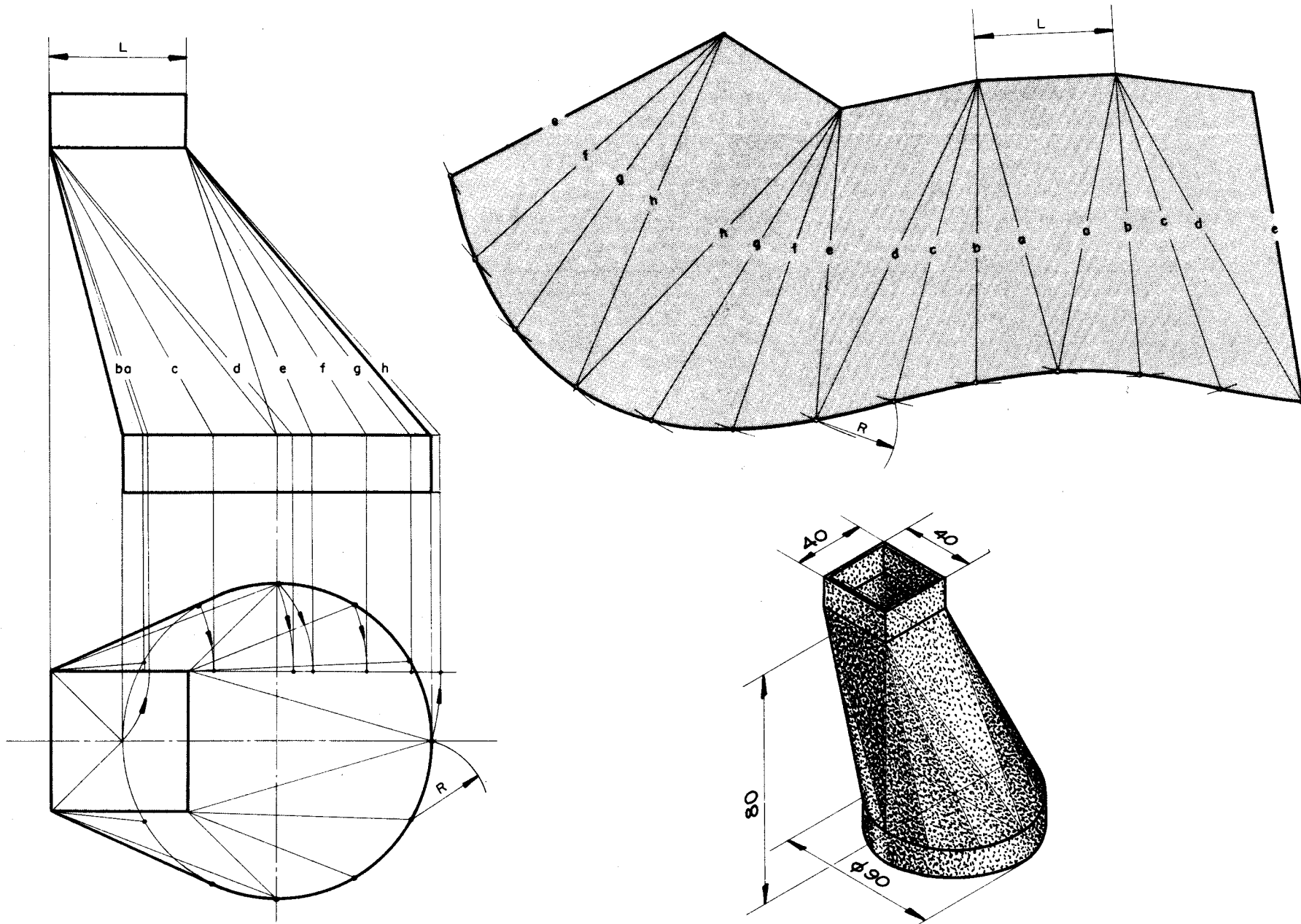

TRANSIÇÃO ANGULAR À 90° DE DUTO REDONDO PARA RETANGULAR

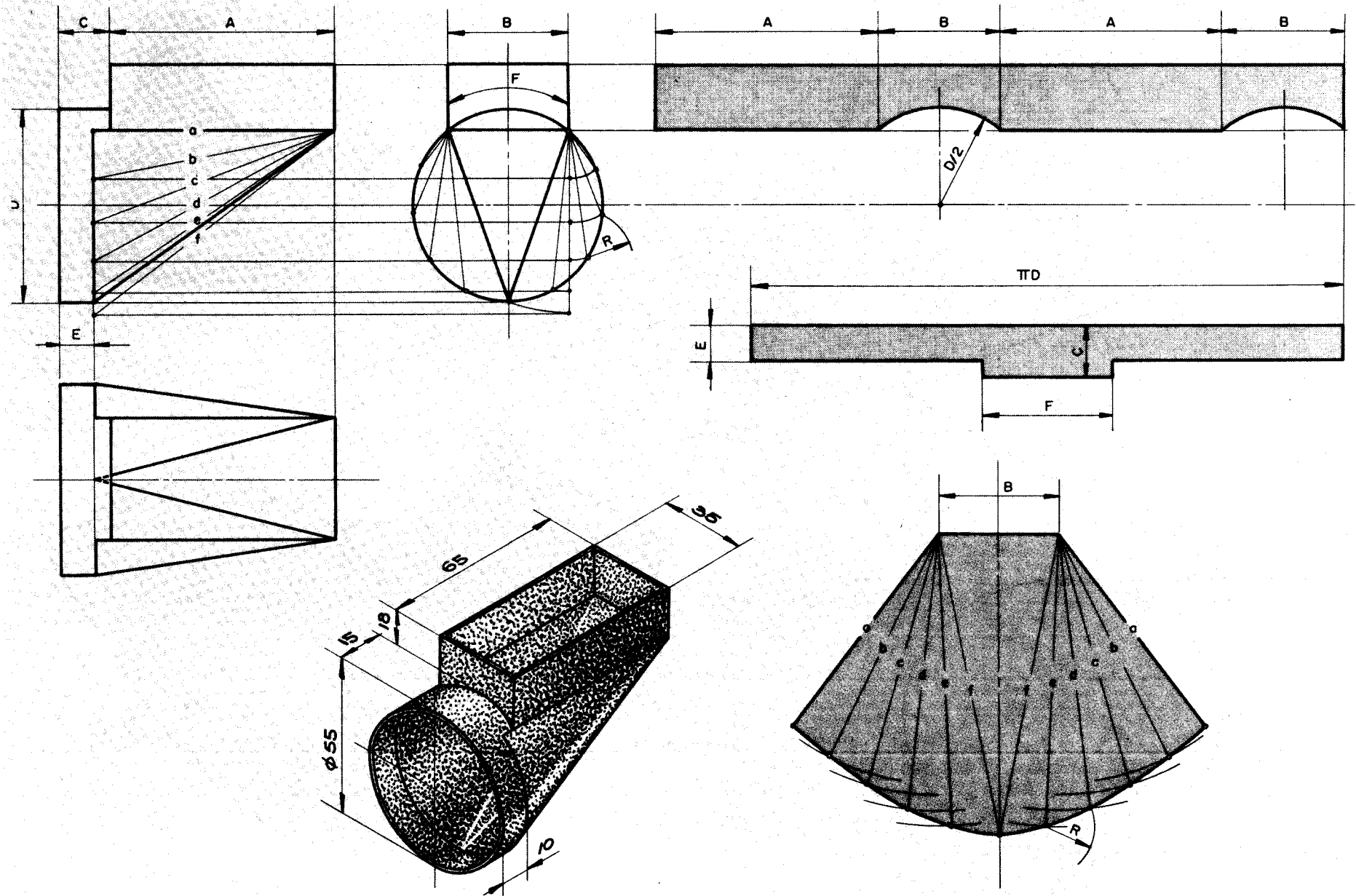

TRANSIÇÃO COM REDUÇÃO DE DUTO REDONDO PARA REDONDO COM DESVIO ANGULAR

(MÉTODO APROXIMADO)

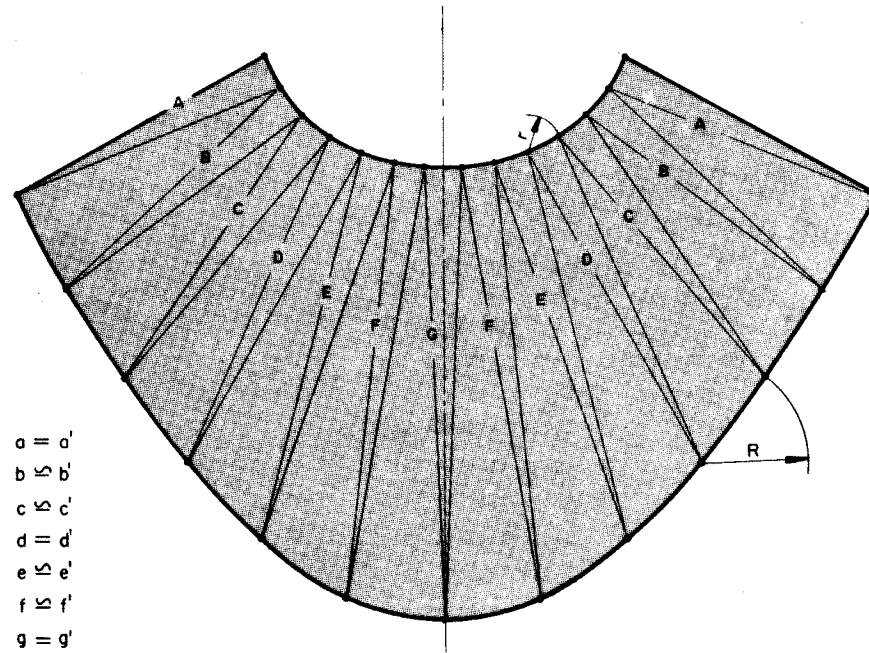
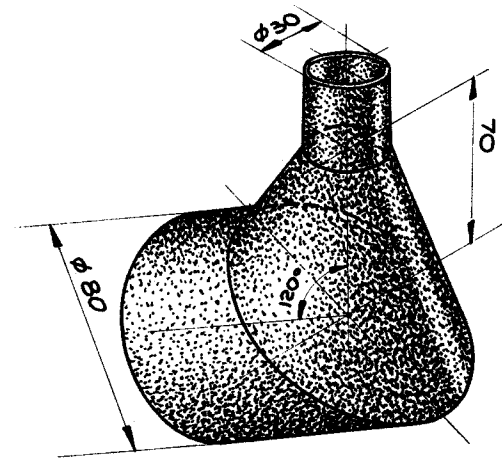
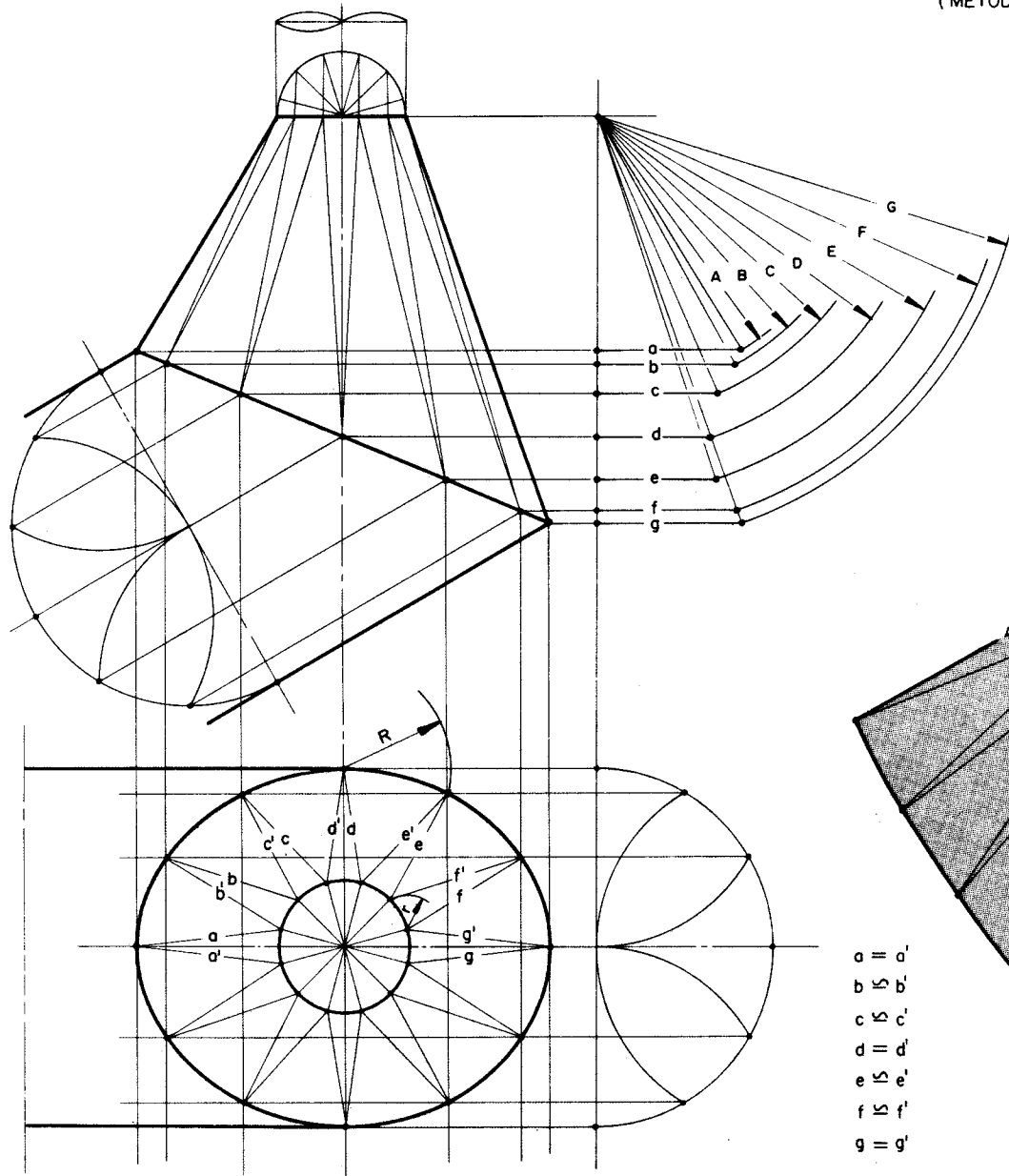

- a || a'
- b || b'
- c || c'
- d || d'
- e || e'
- f || f'
- g || g'

TRANSIÇÃO COM REDUÇÃO DE DUTO REDONDO PARA OVAL COM DESVIO PARARELO

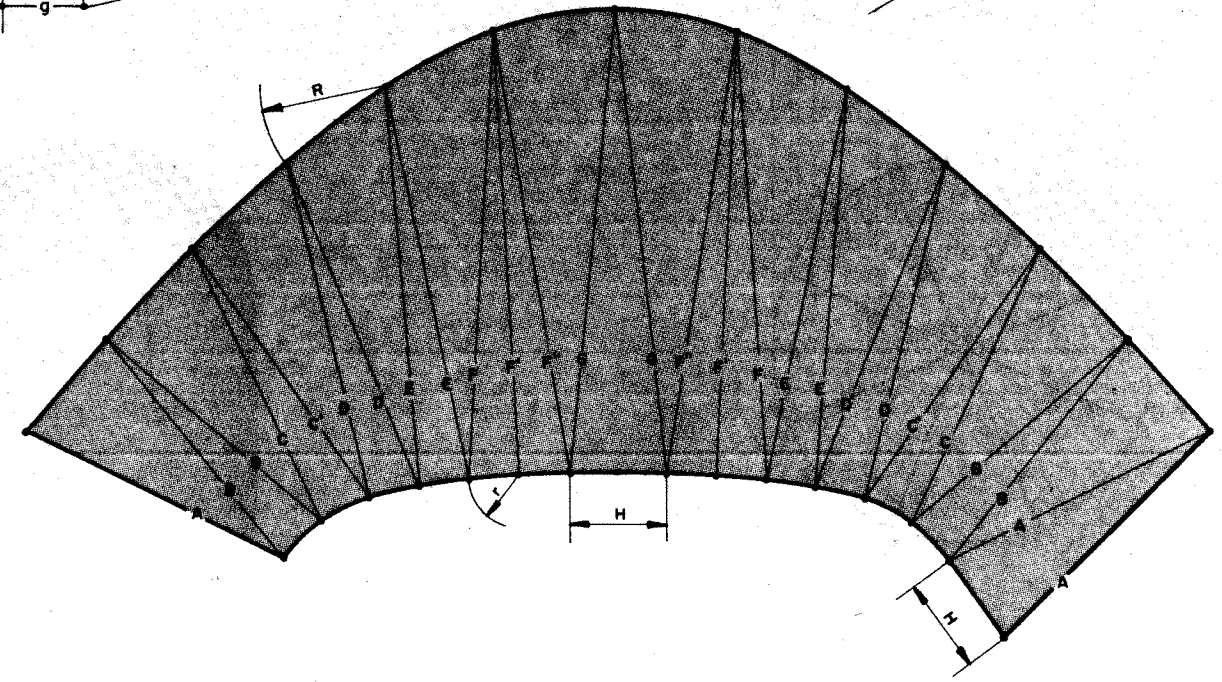
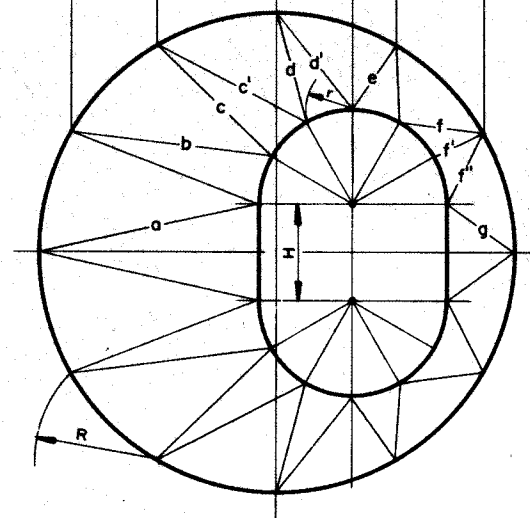
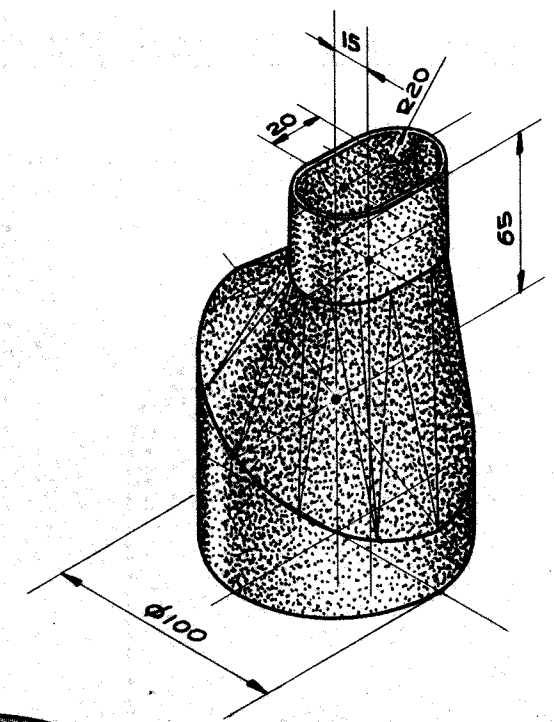
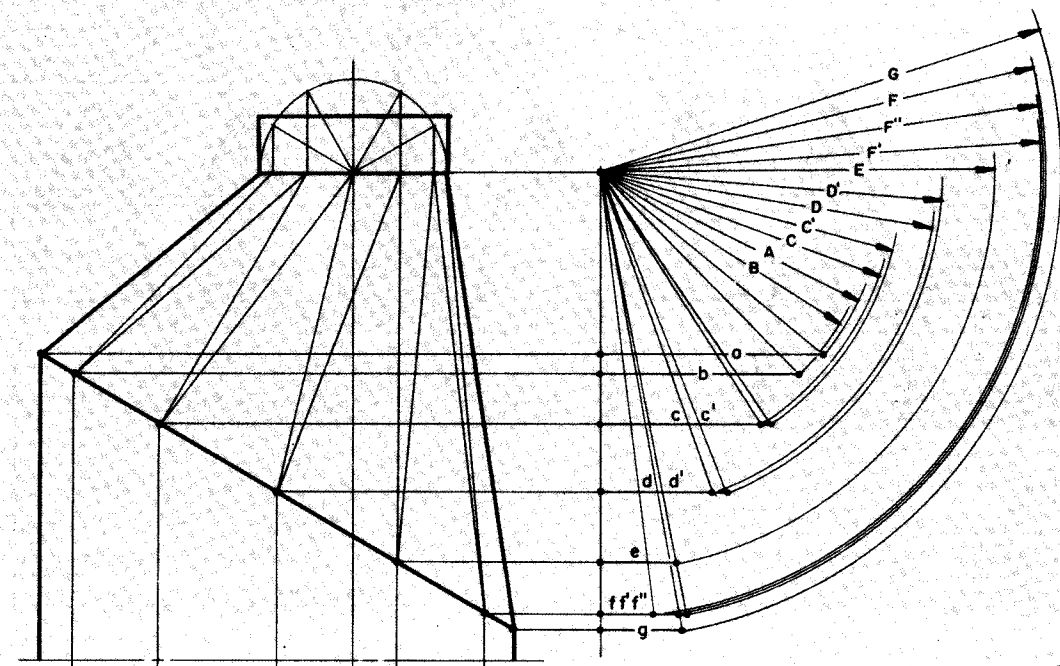

FECHAMENTO ESFÉRICO DE DUTO REDONDO

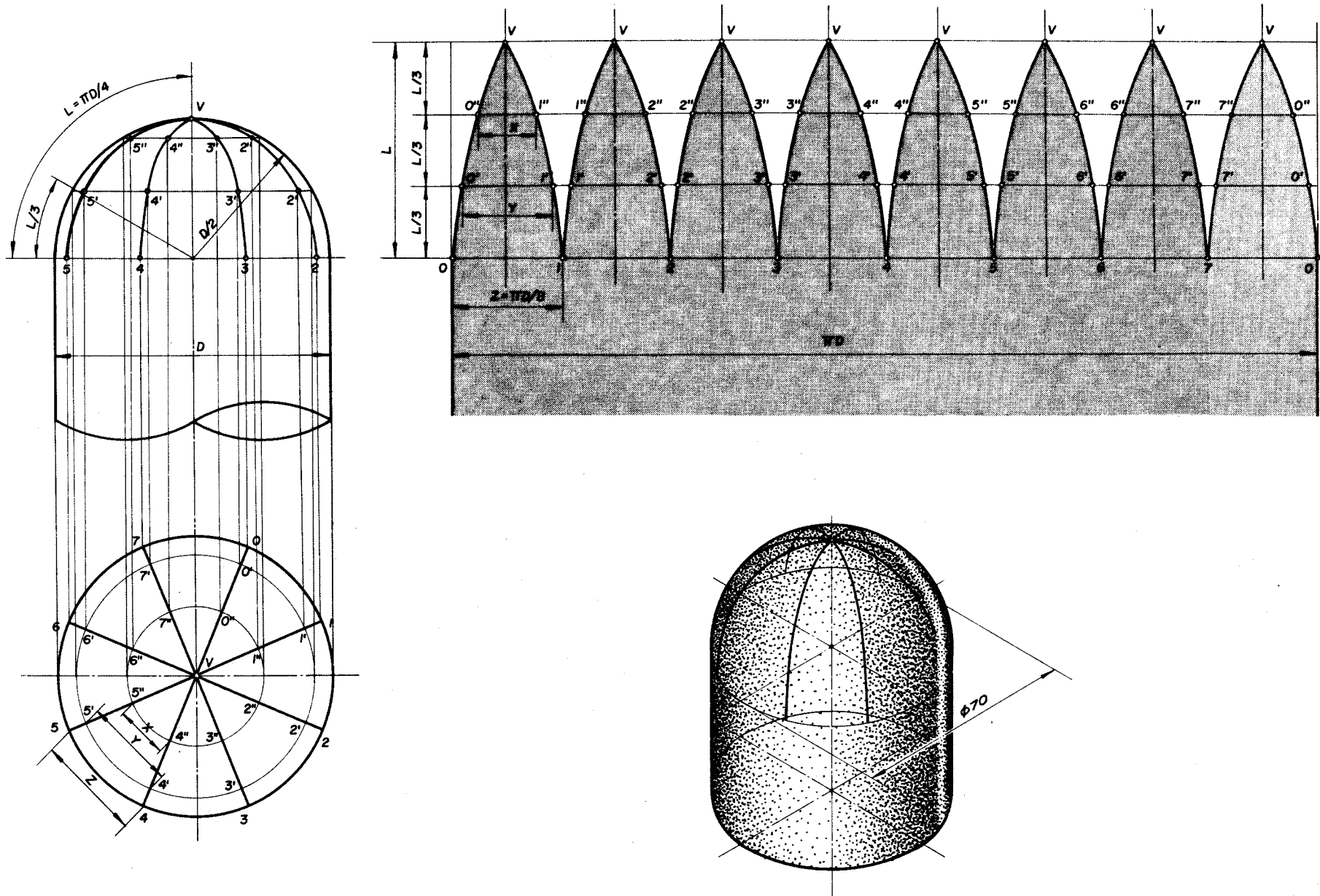

ESFERA

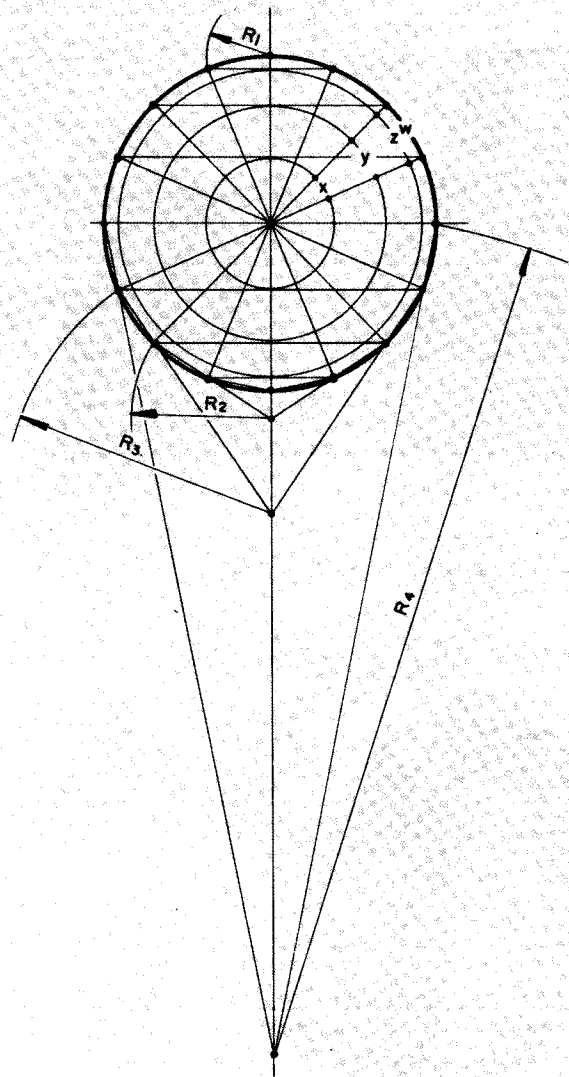

PROCESSO DAS ZONAS

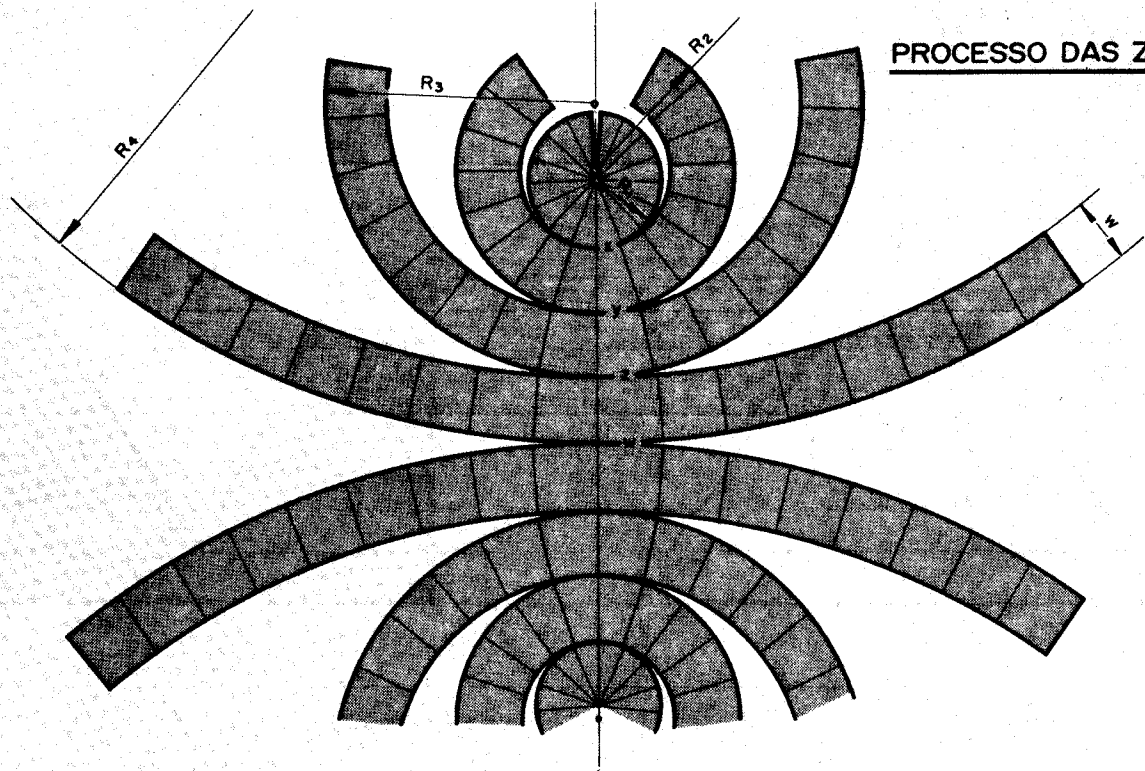

PROCESSO DOS FUSOS

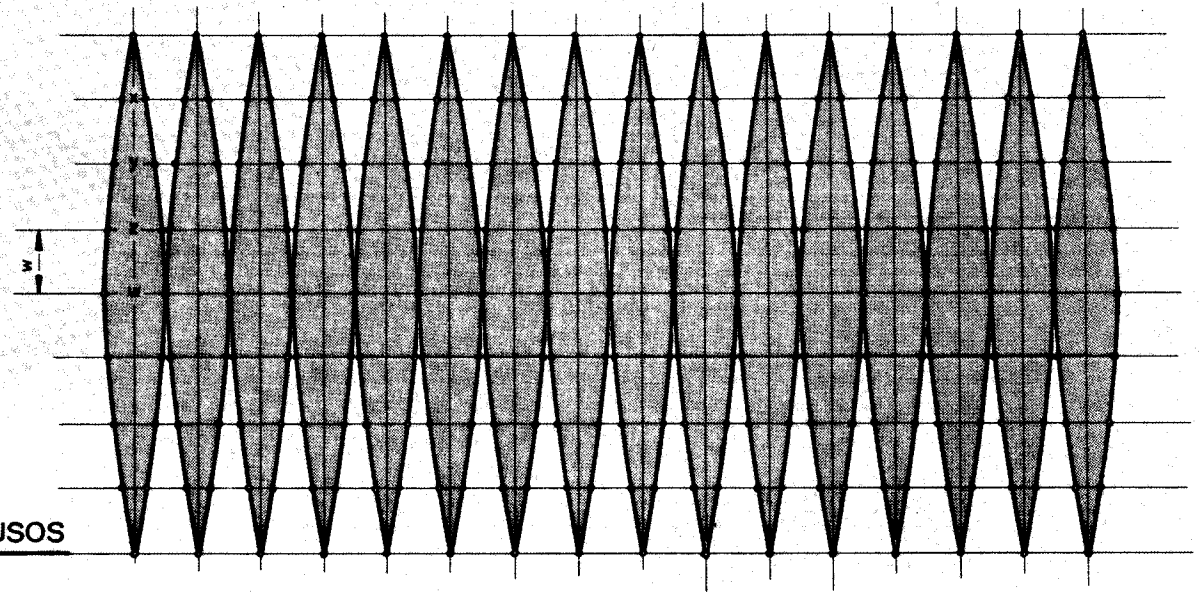

COIFA

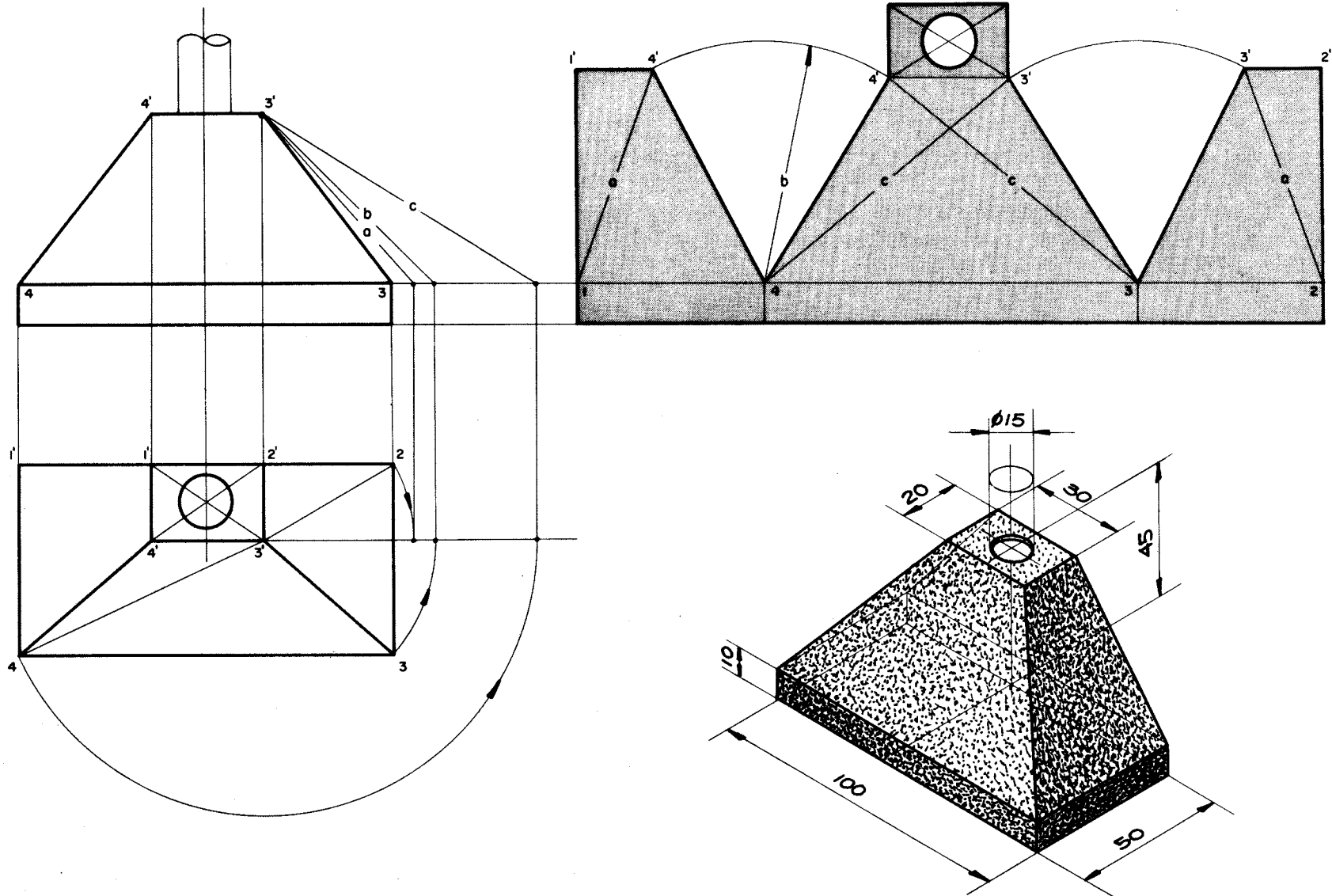

RECIPIENTE DE BASE ELÍPTICA

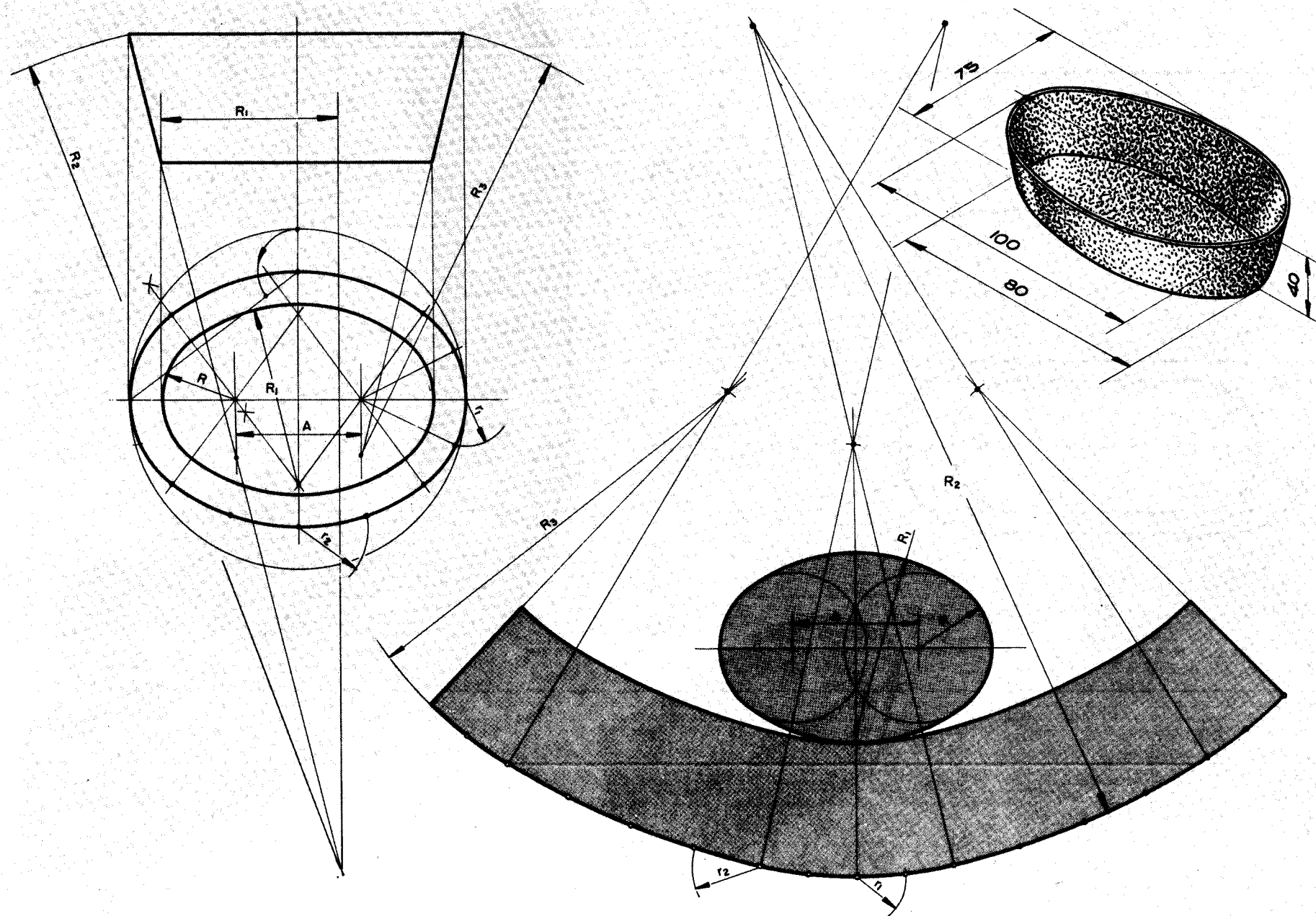

BANHEIRA

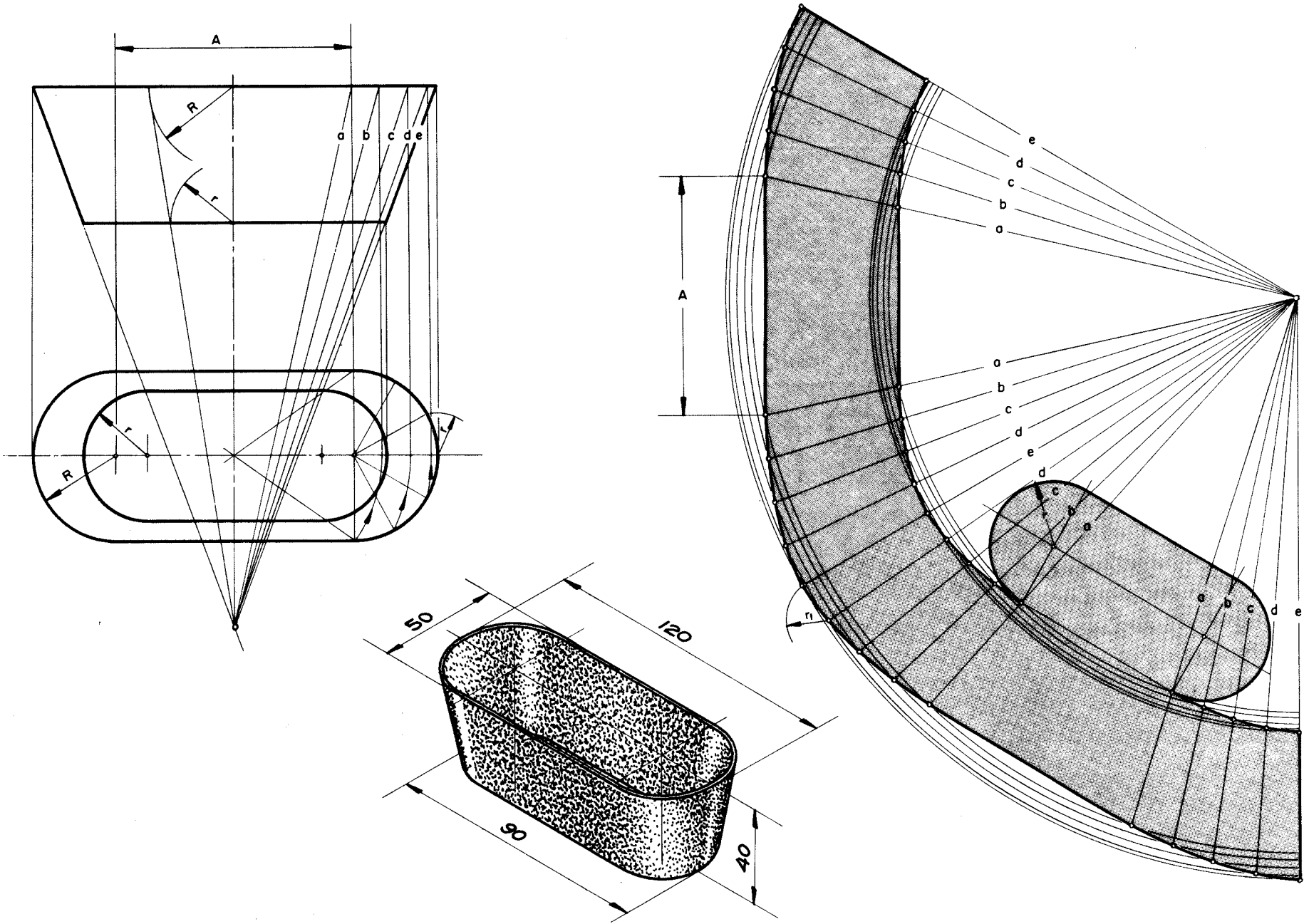

CALHA

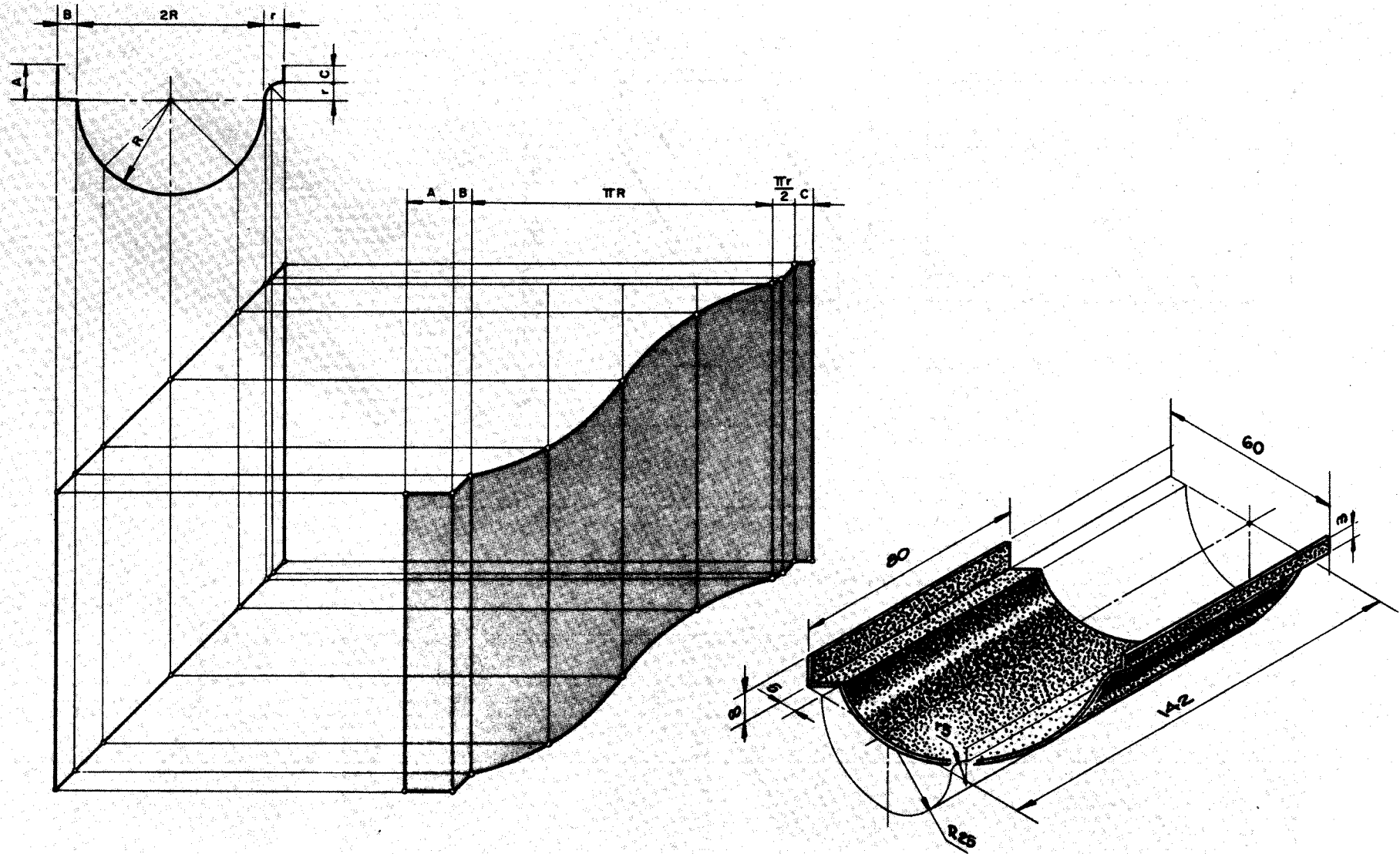

DESVIO PARALELO DE DUTOS RETANGULARES

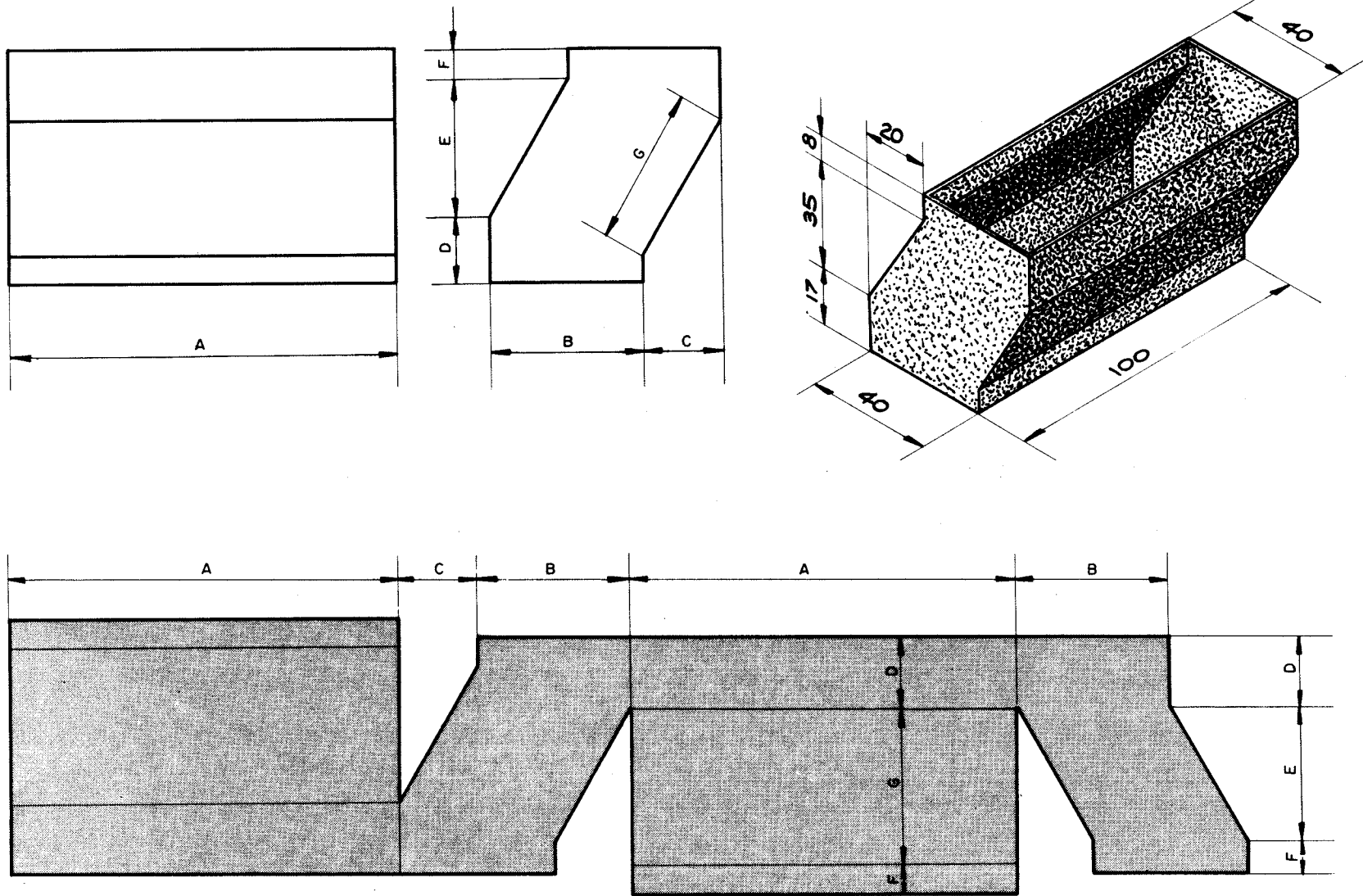

DESVIO ANGULAR

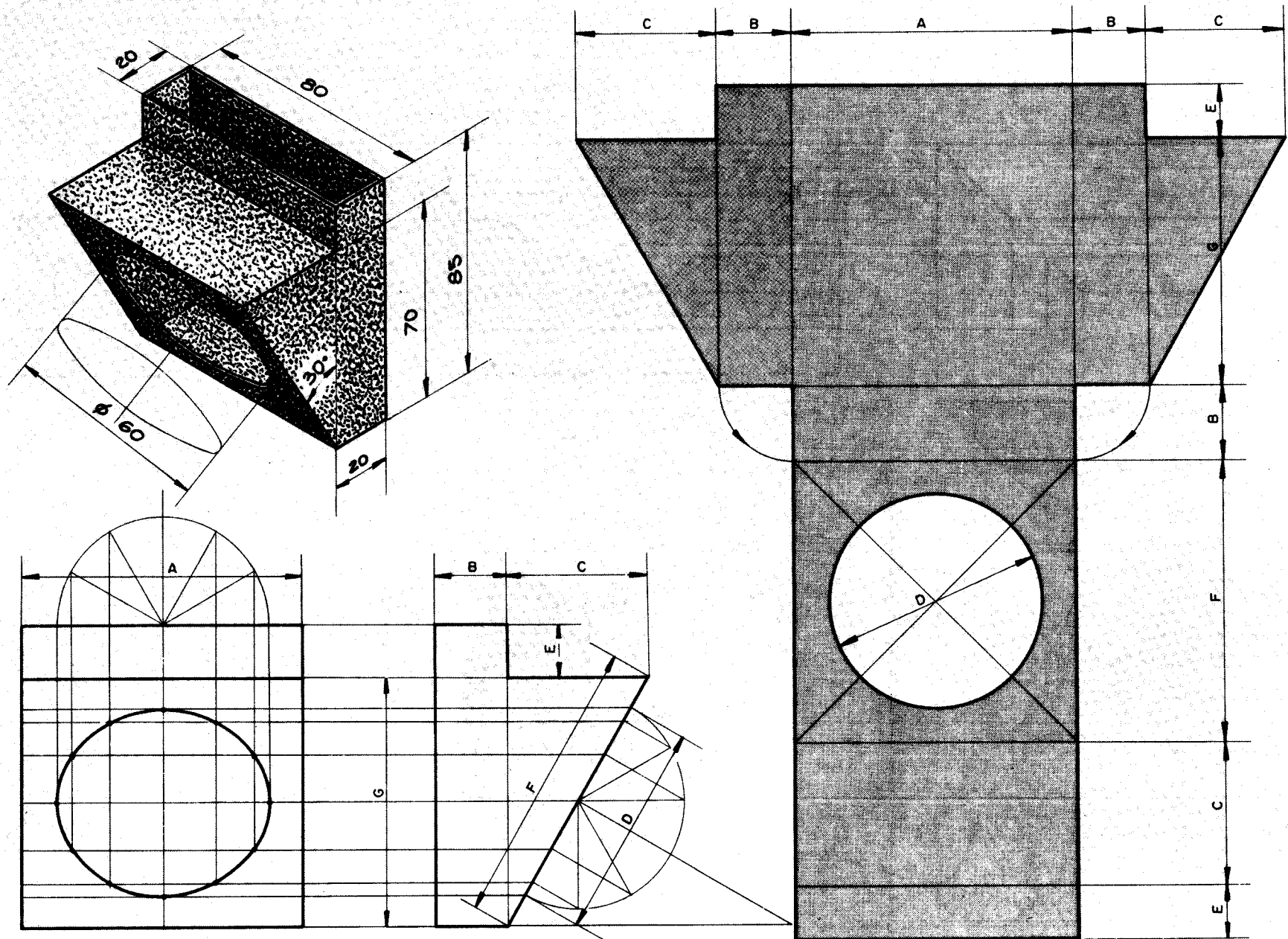

MOLDURA

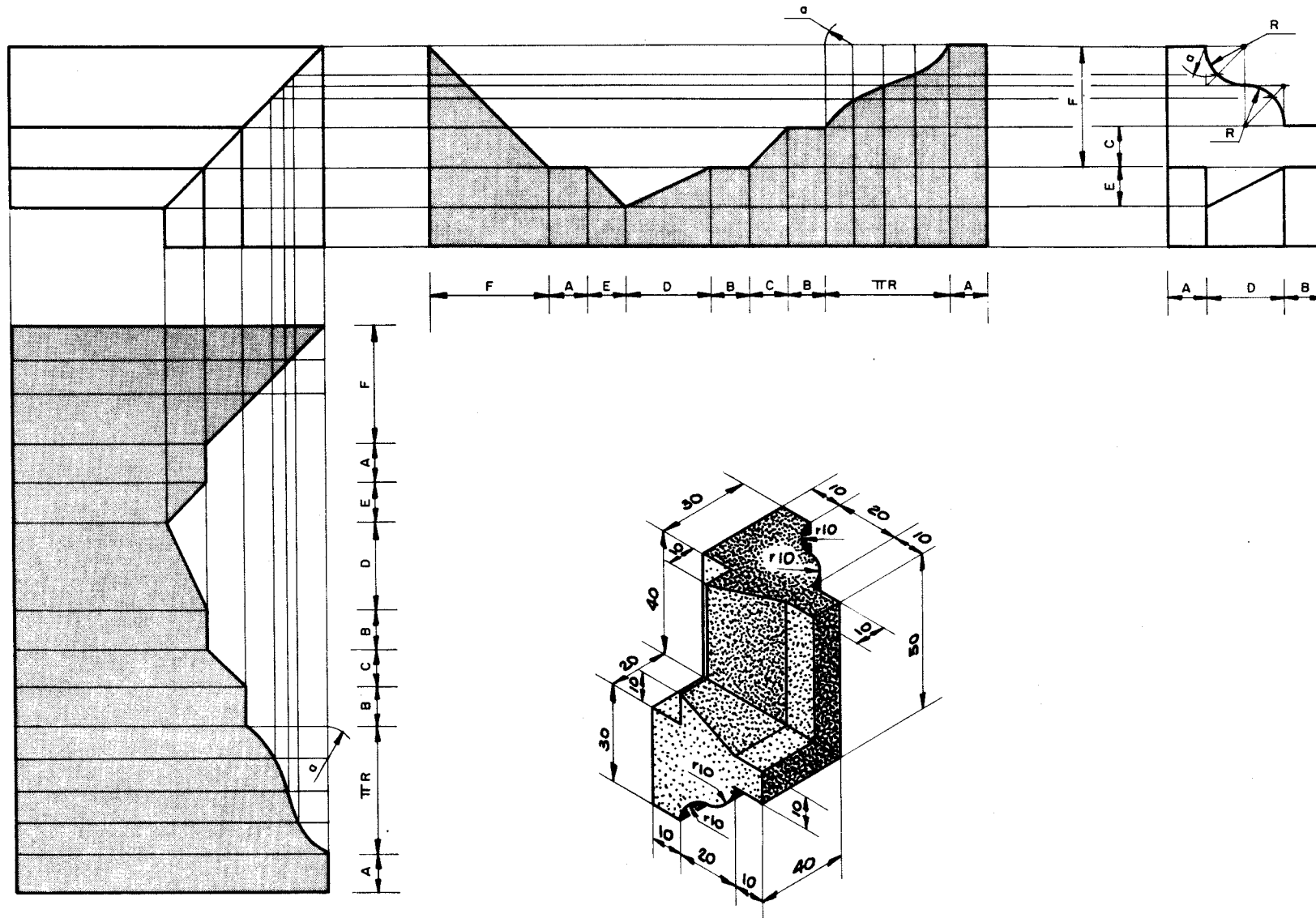

INTERSECÇÃO PERPENDICULAR DE DUTOS QUADRADOS

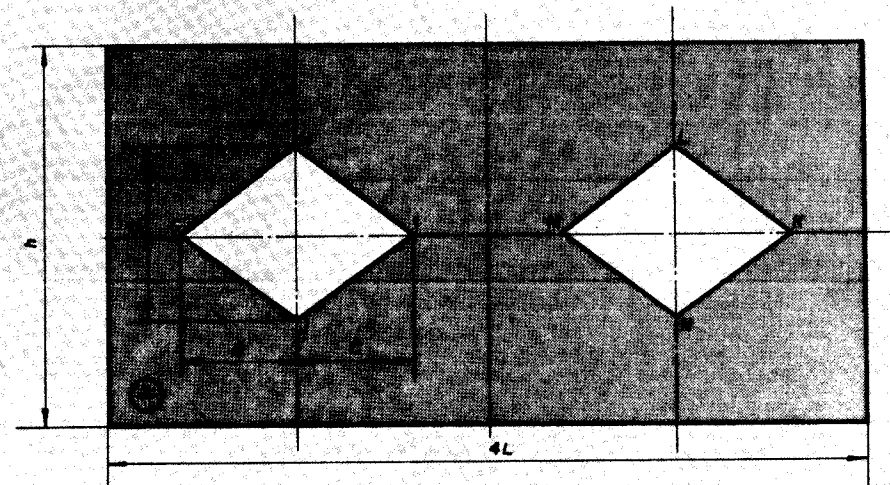
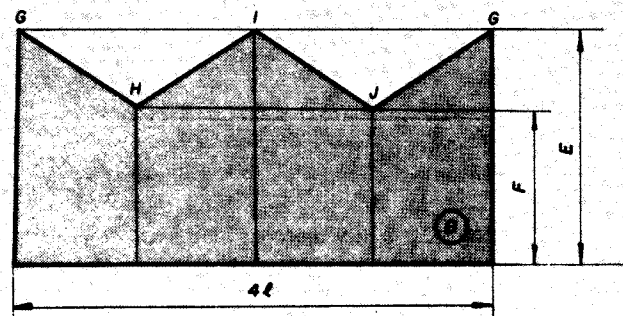
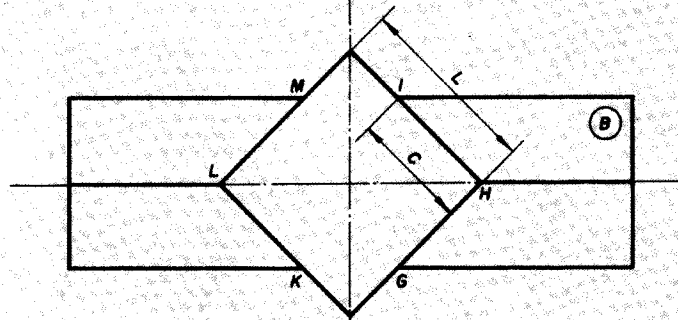
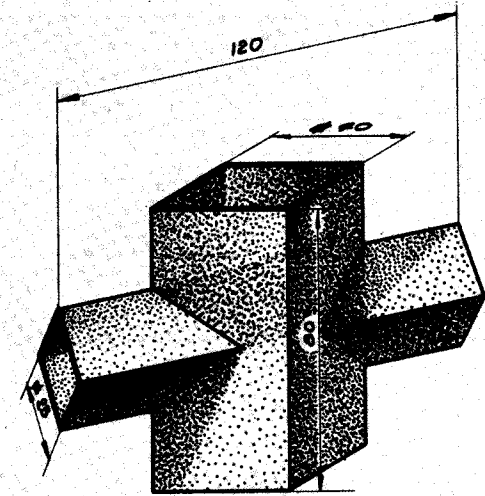
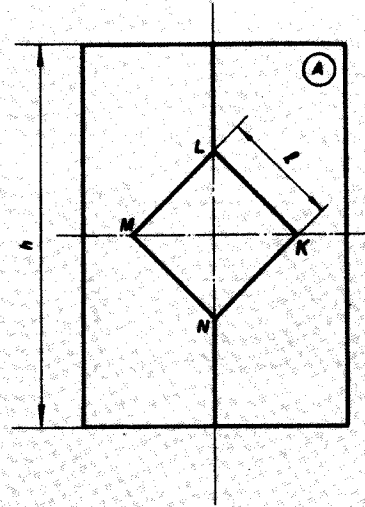
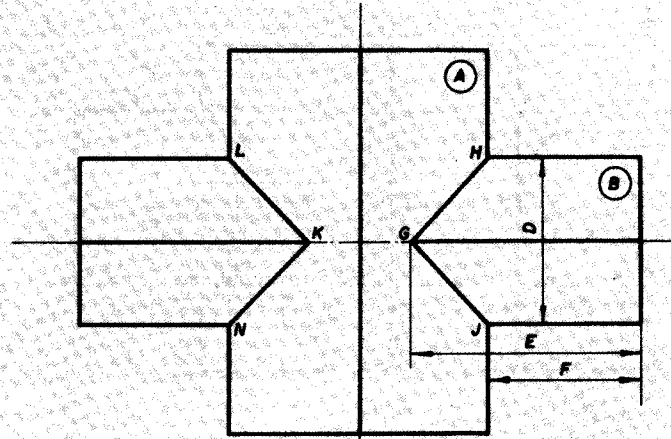

INTERSECÇÃO PERPENDICULAR DE DUTOS REDONDOS COM DIÂMETROS IGUAIS

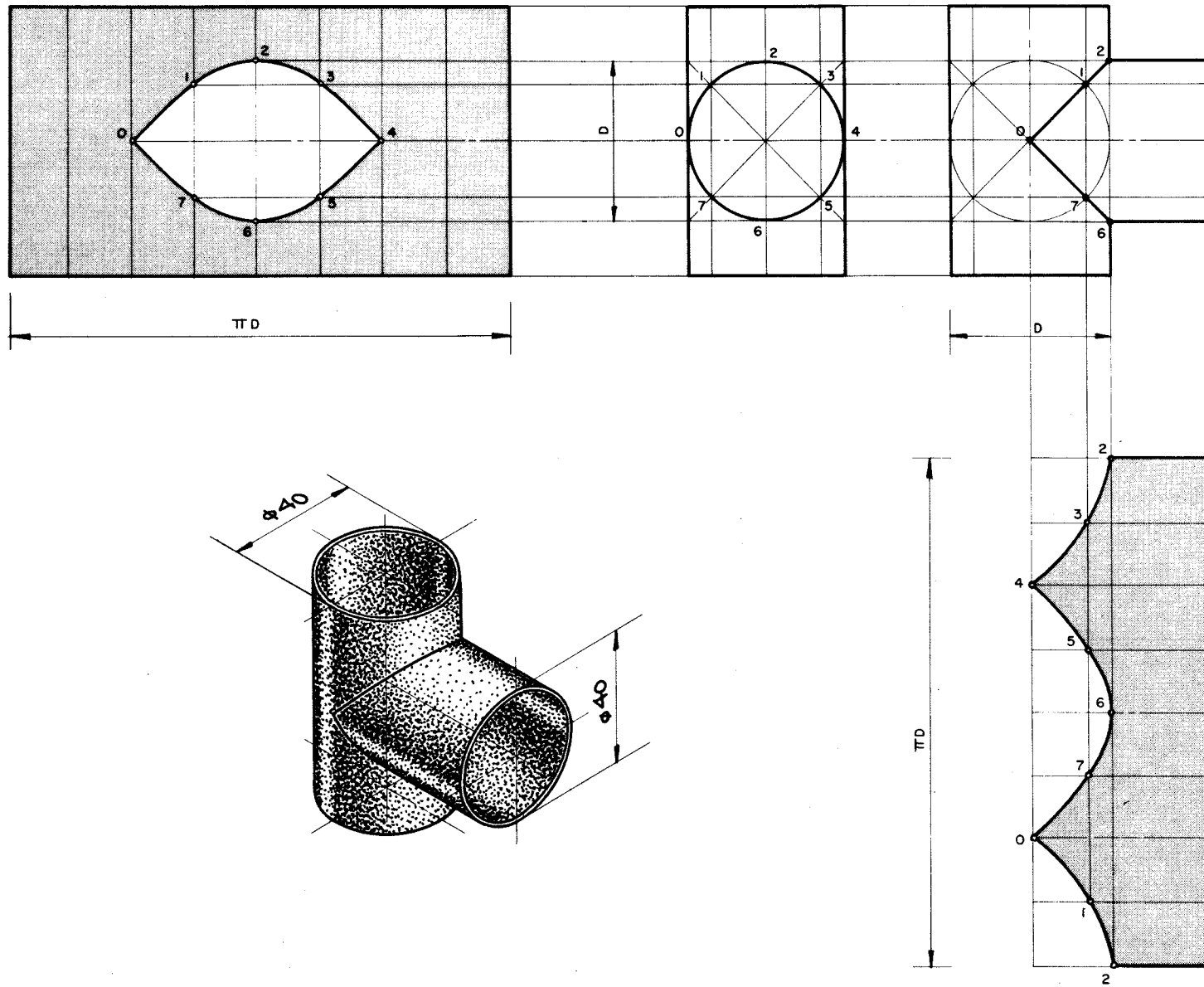

INTERSECÇÃO PERPENDICULAR DE DUTOS REDONDOS COM DIÂMETROS DIFERENTES

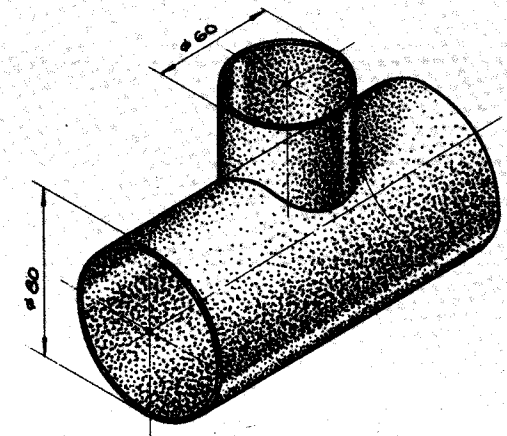
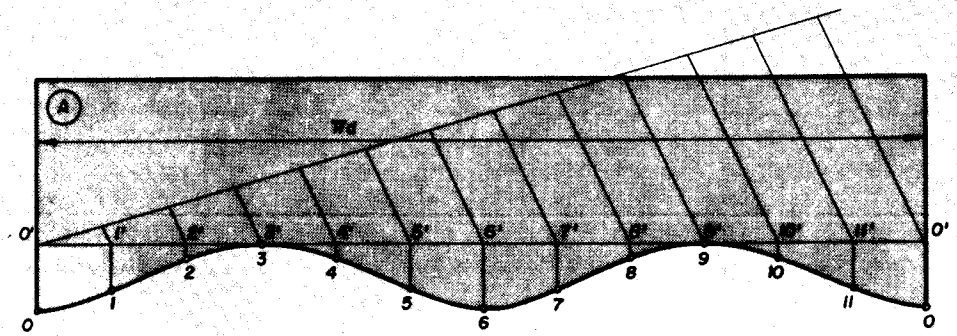
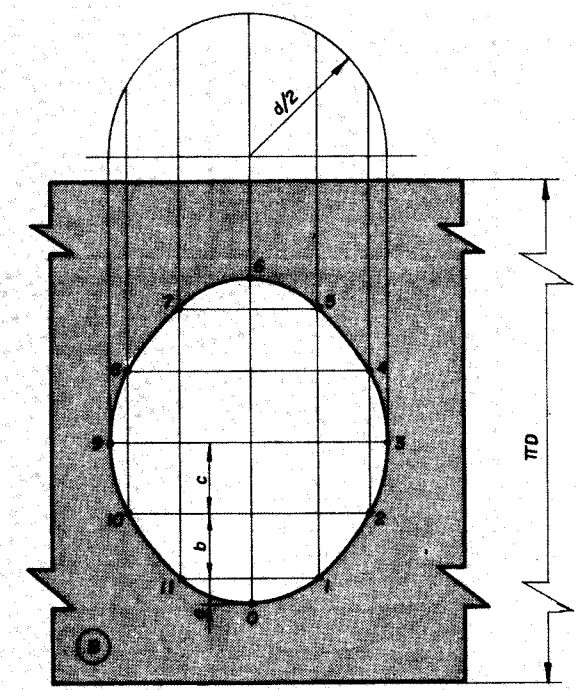
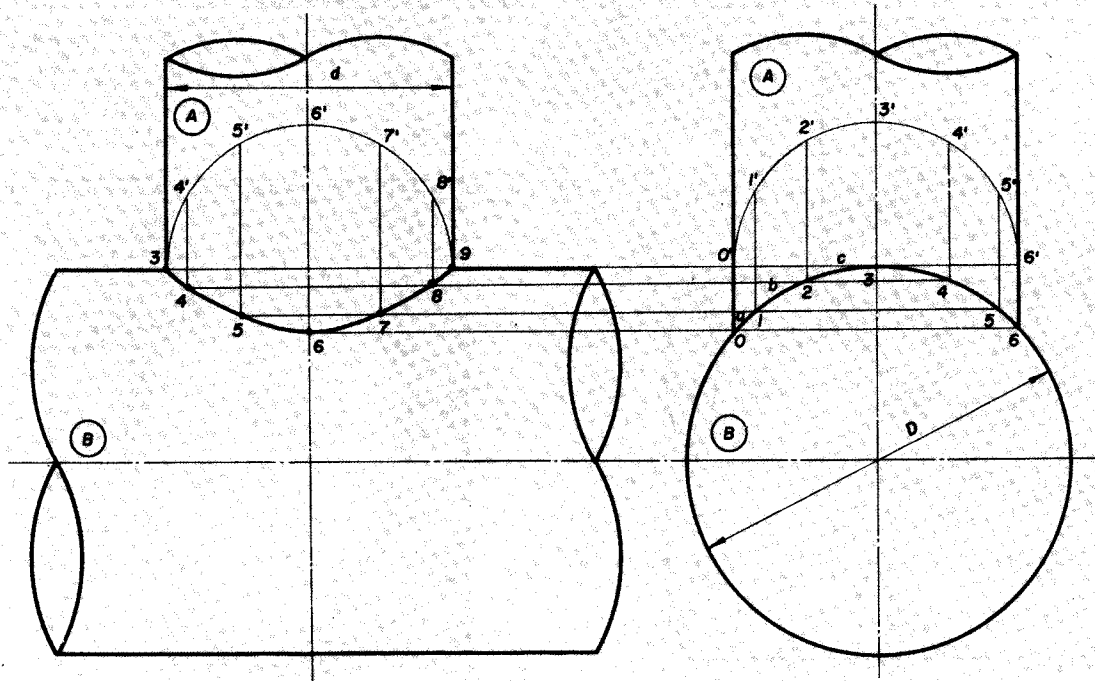

INTERSECÇÃO ORTOGONAL DE DUTOS REDONDOS

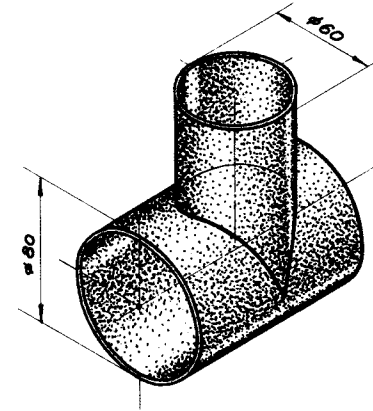
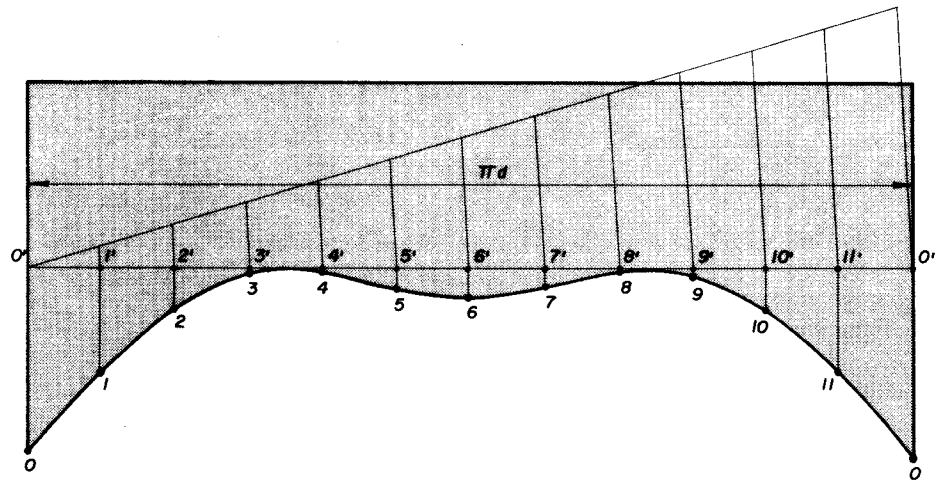
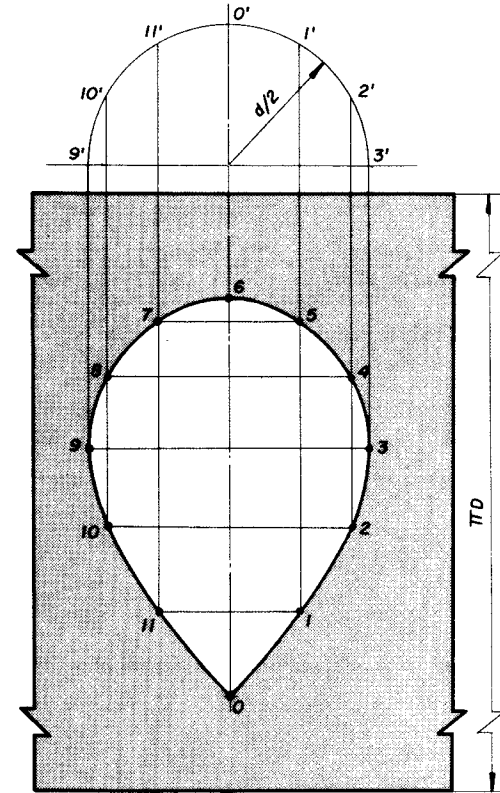
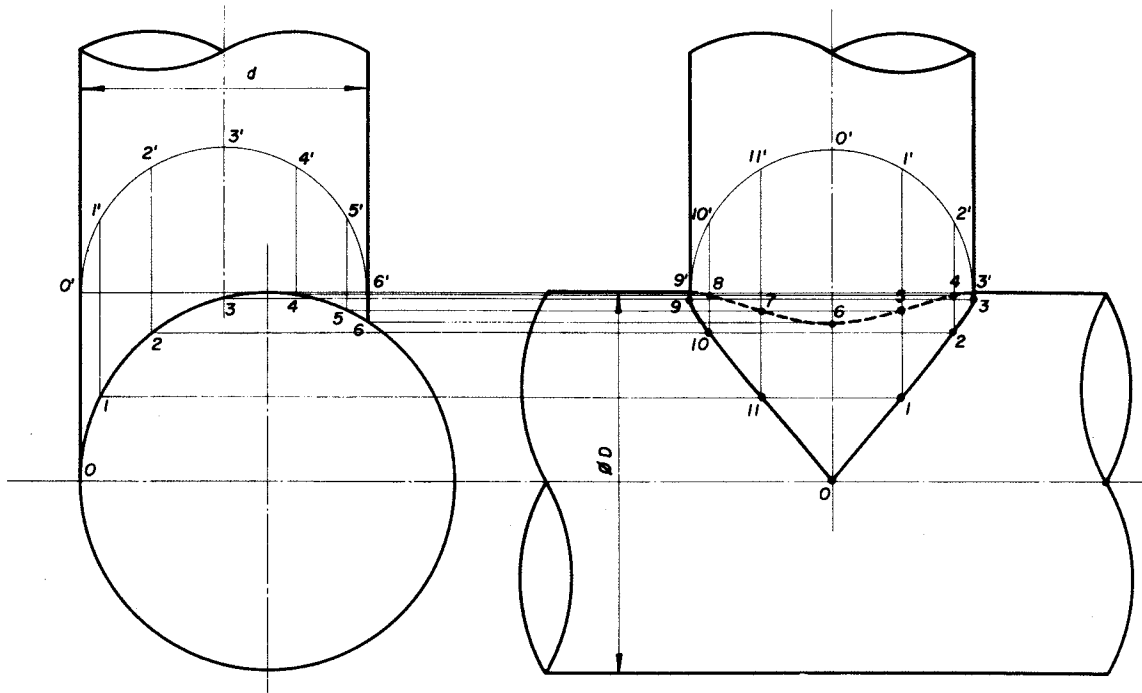

INTERSECÇÃO OBLÍQUA DE DUTOS REDONDOS COM DIÂMETROS DIFERENTES

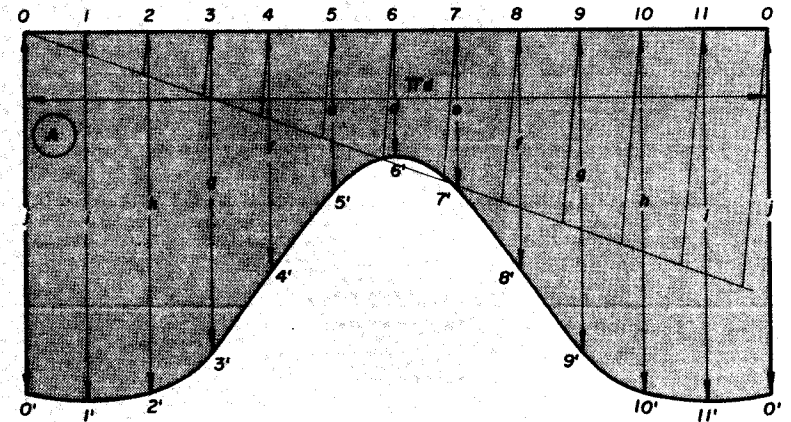
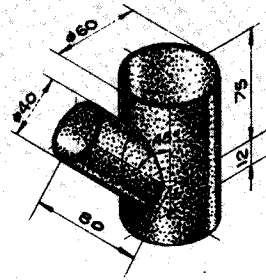
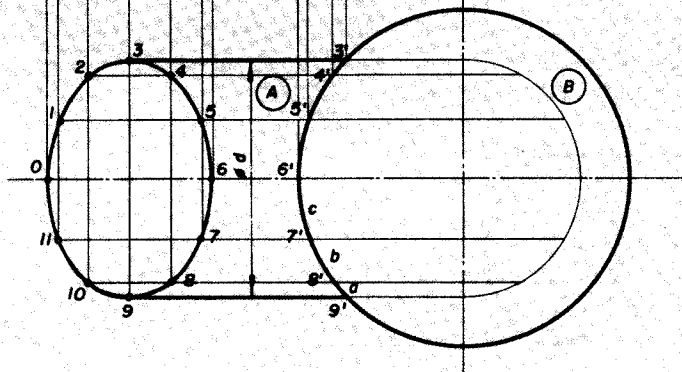
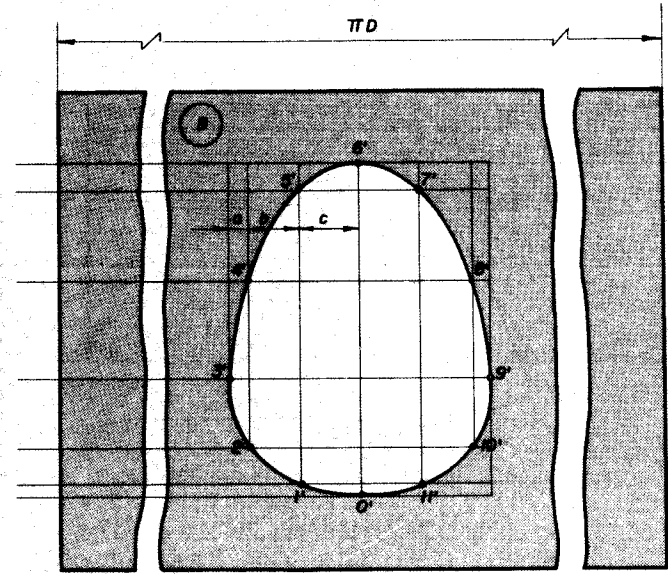
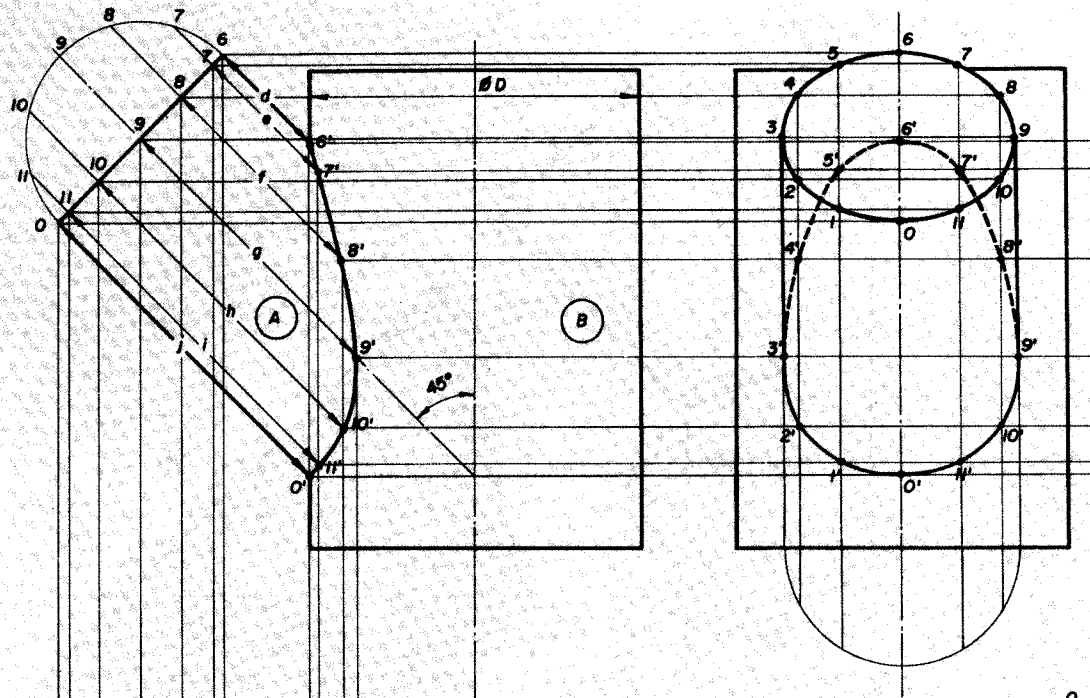

INTERSECÇÃO OBLÍQUA DE DUTOS REDONDOS COM DIÂMETROS IGUAIS

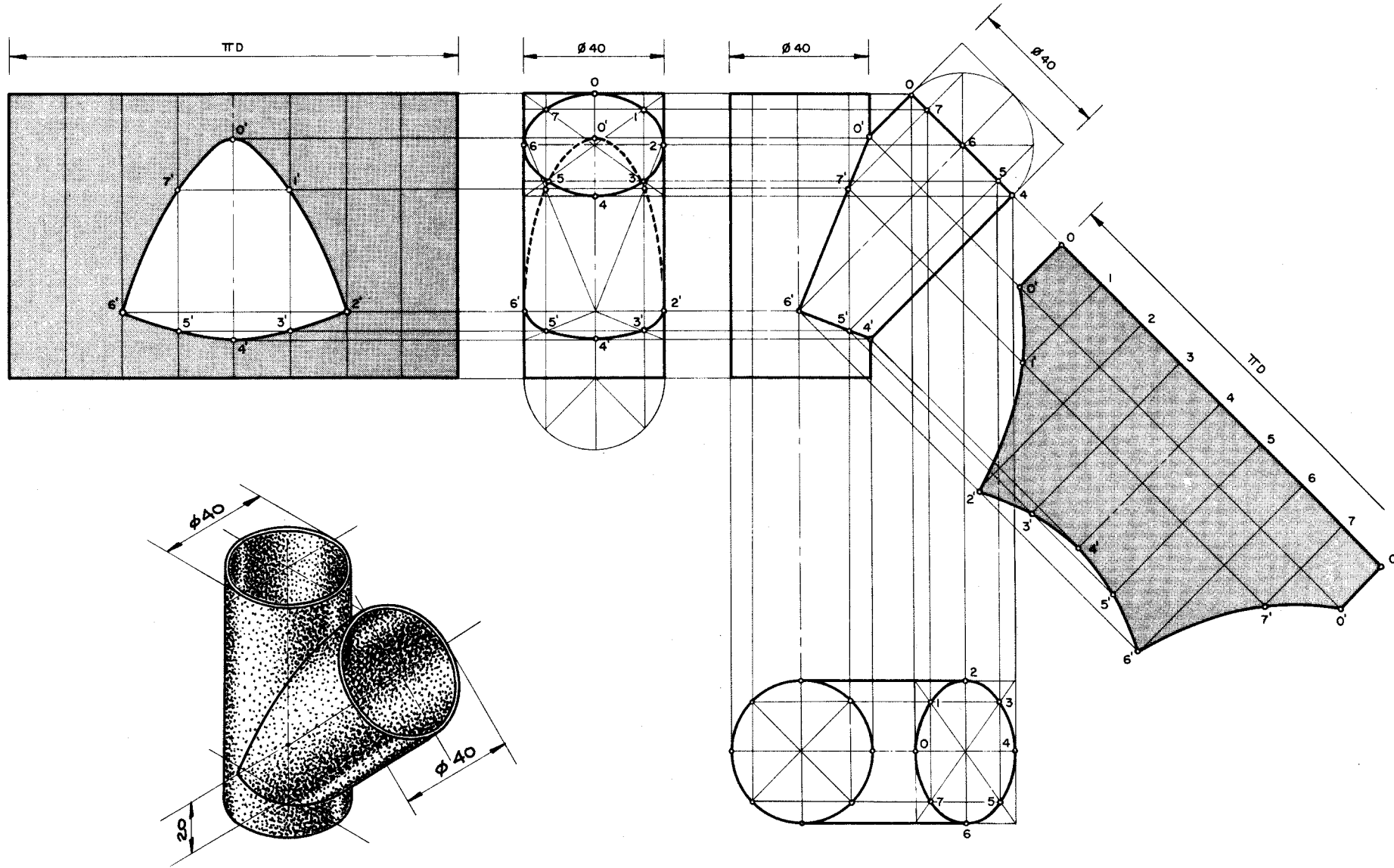

BIFURCAÇÃO SIMÉTRICA DE DUTOS REDONDOS

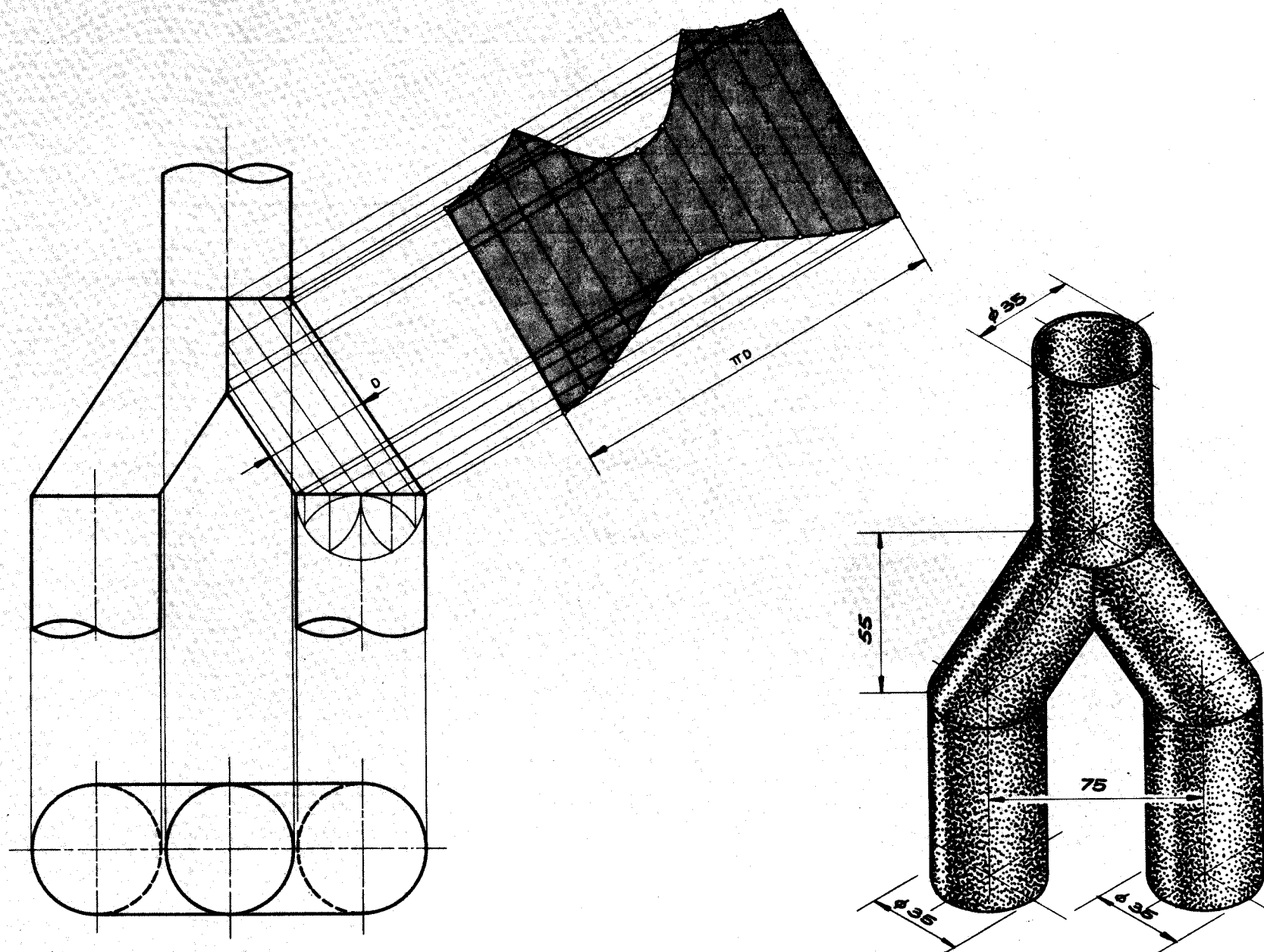

INTERSECÇÃO DE TRÊS DUTOS REDONDOS COM DIÂMETROS IGUAIS

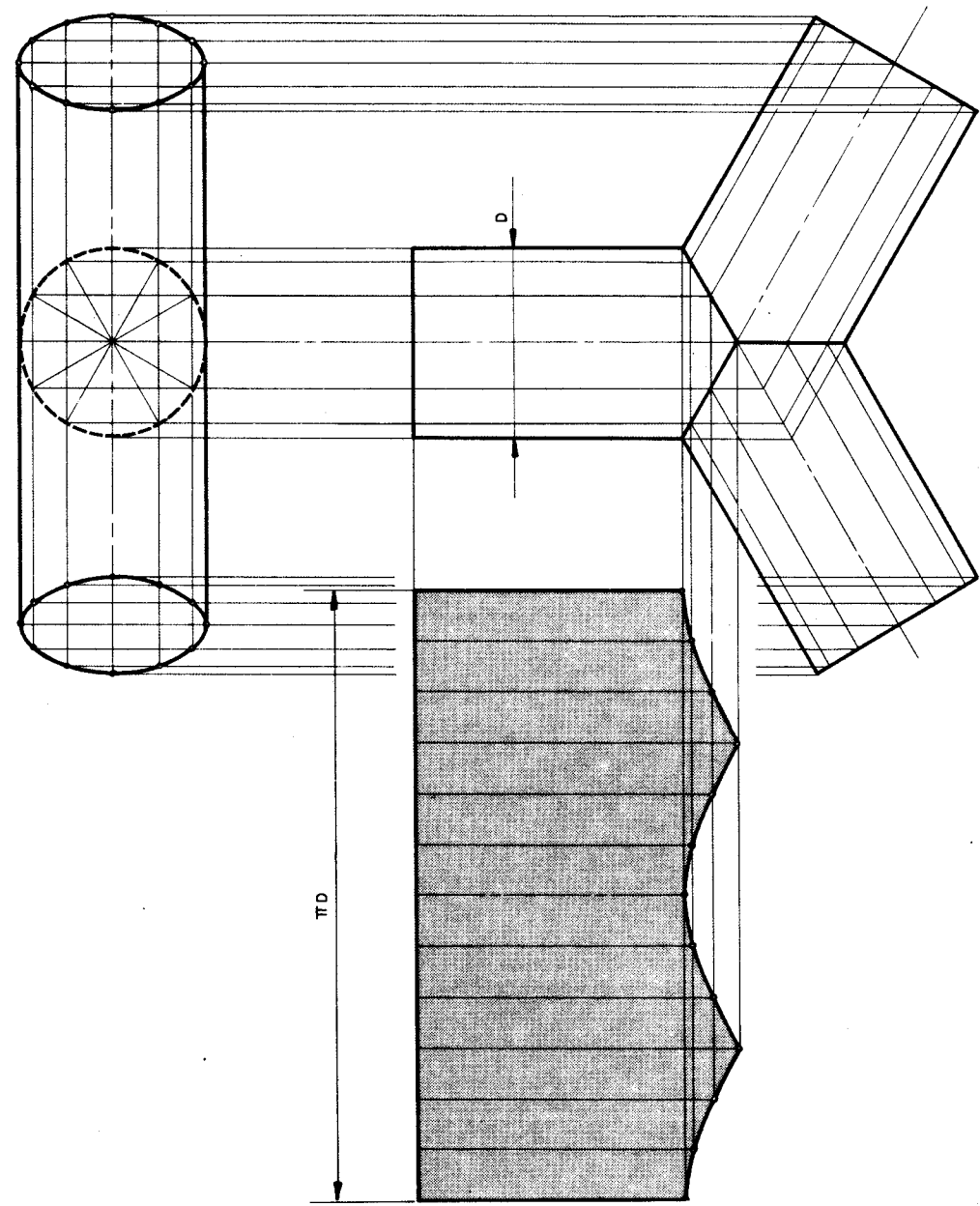
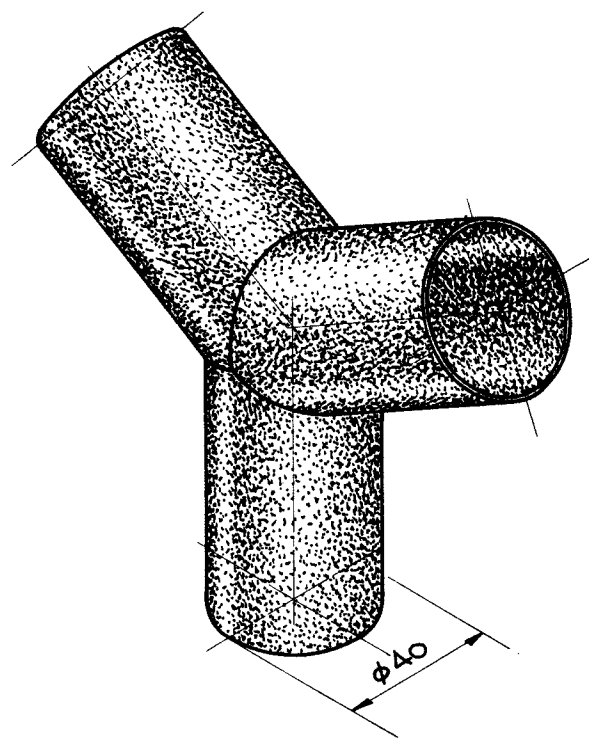

REDUÇÃO COM BIFURCAÇÃO SIMÉTRICA DE DUTOS REDONDOS

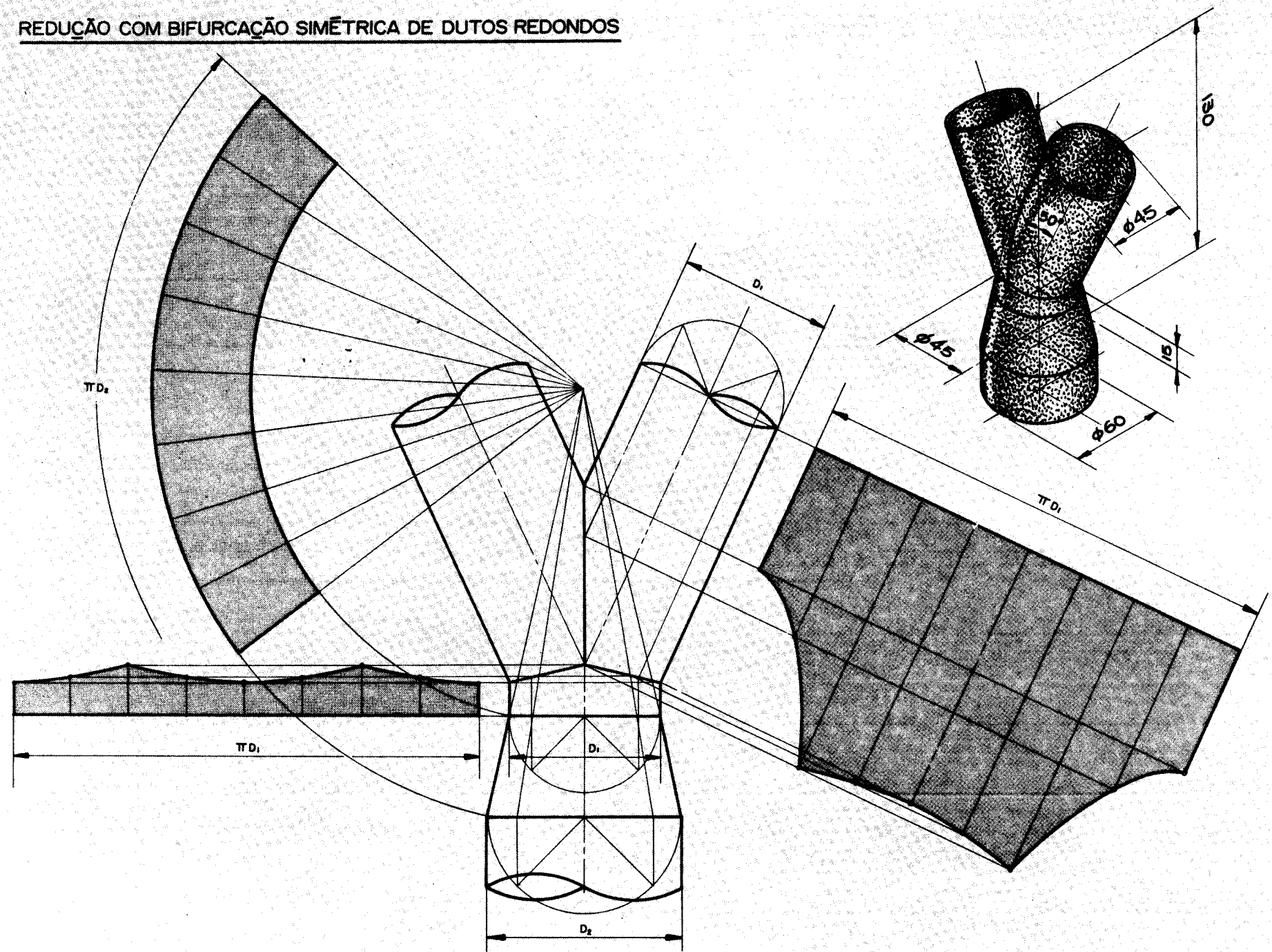

INTERSECÇÃO PERPENDICULAR DE UM CONE RETO COM UM DUTO REDONDO

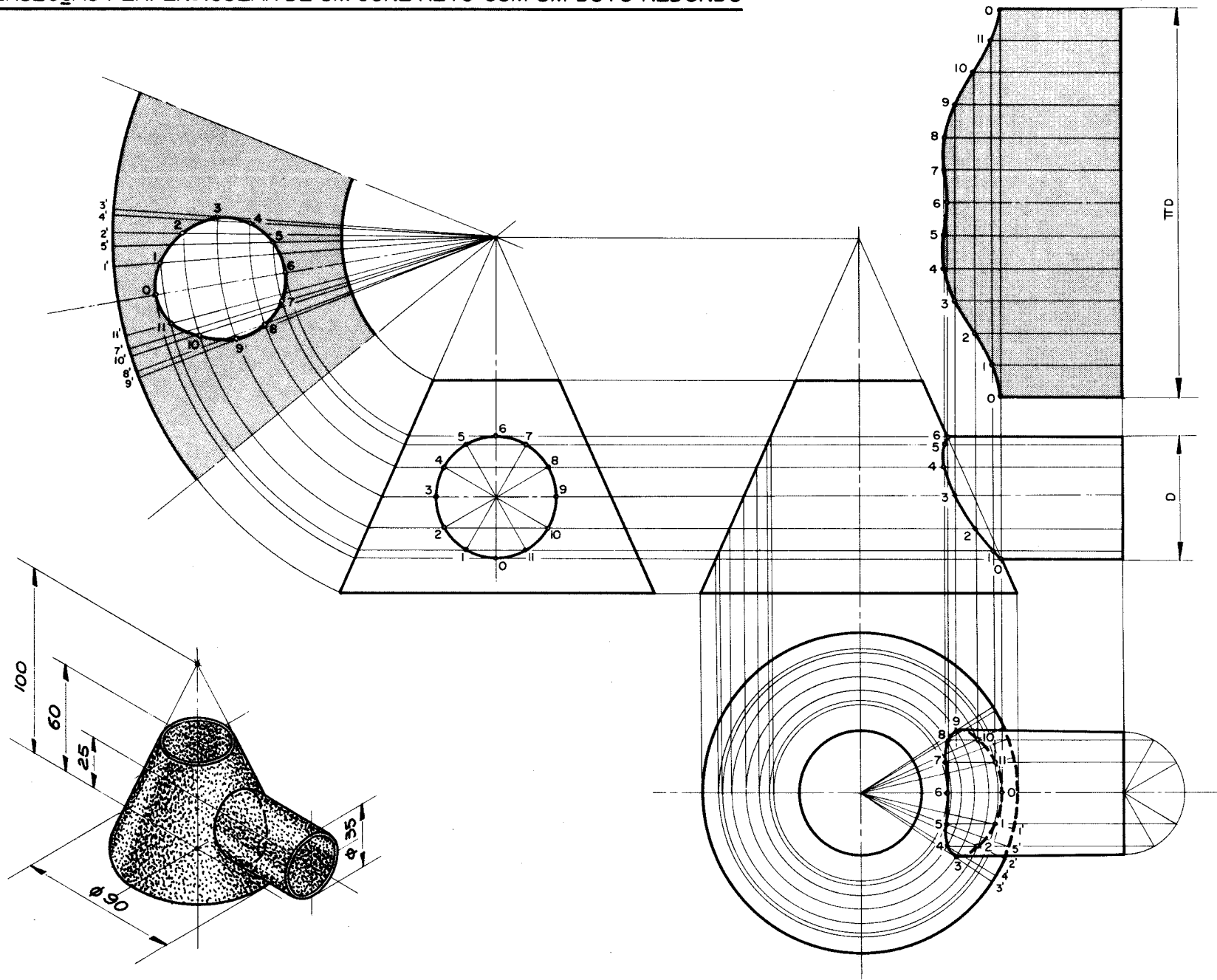

INTERSECÇÃO PARALELA DE UM CONE RETO COM UM DUTO REDONDO

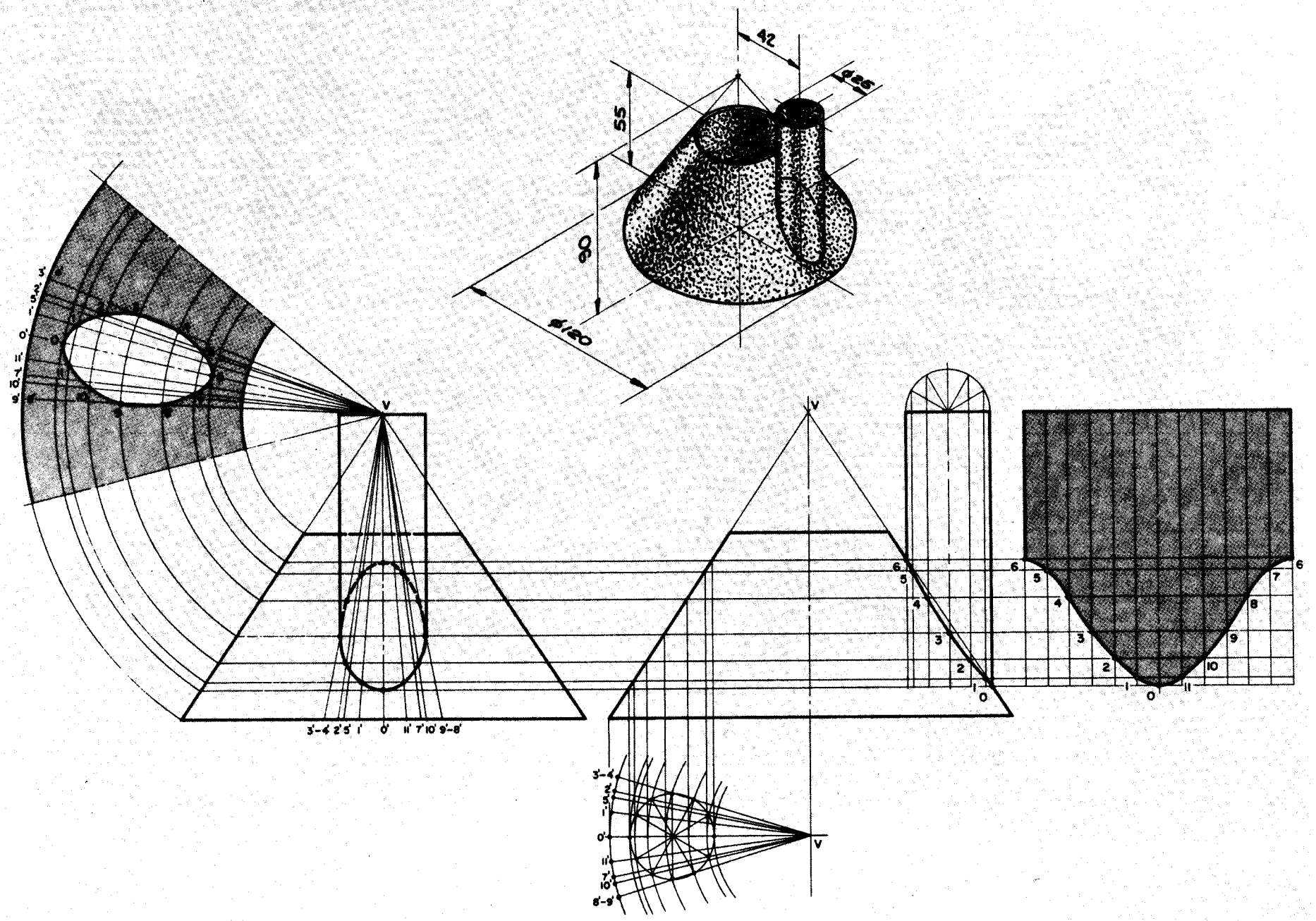

INTERSECÇÃO OBLÍQUA DE UM CONE RETO COM UM DUTO REDONDO

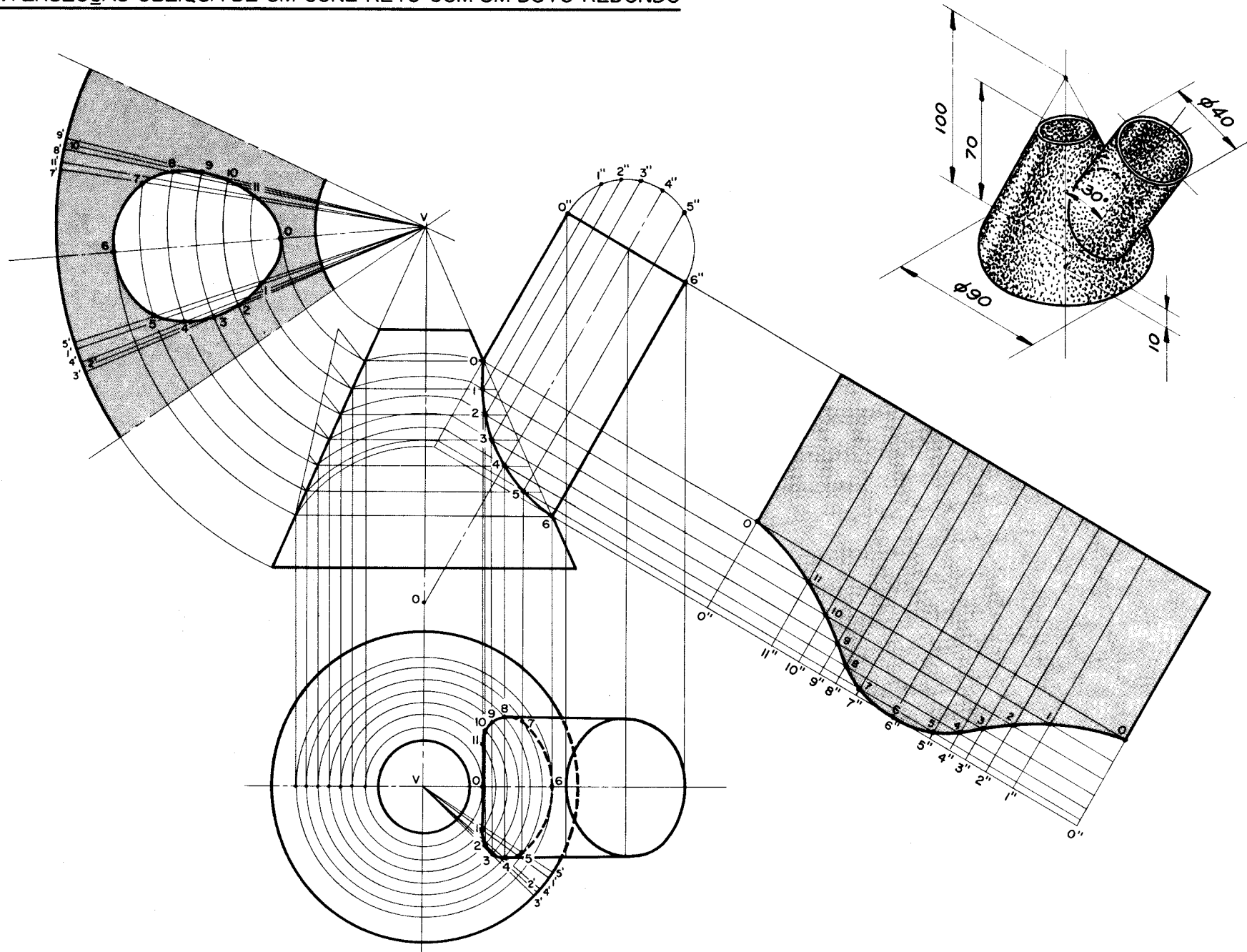

INTERSECÇÃO OBLÍQUA DE DOIS CONES

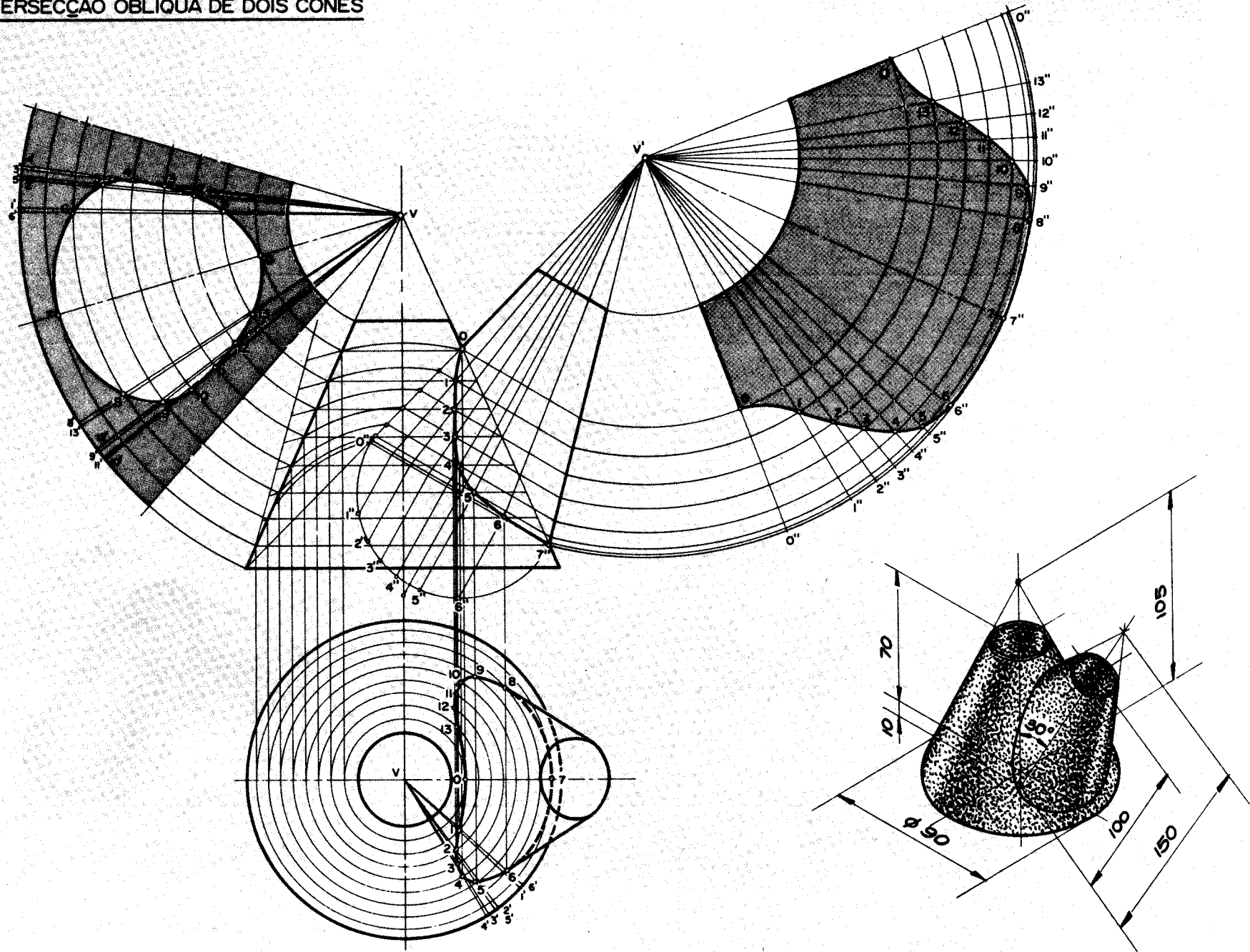

BIFURCAÇÃO SIMÉTRICA COM REDUÇÃO

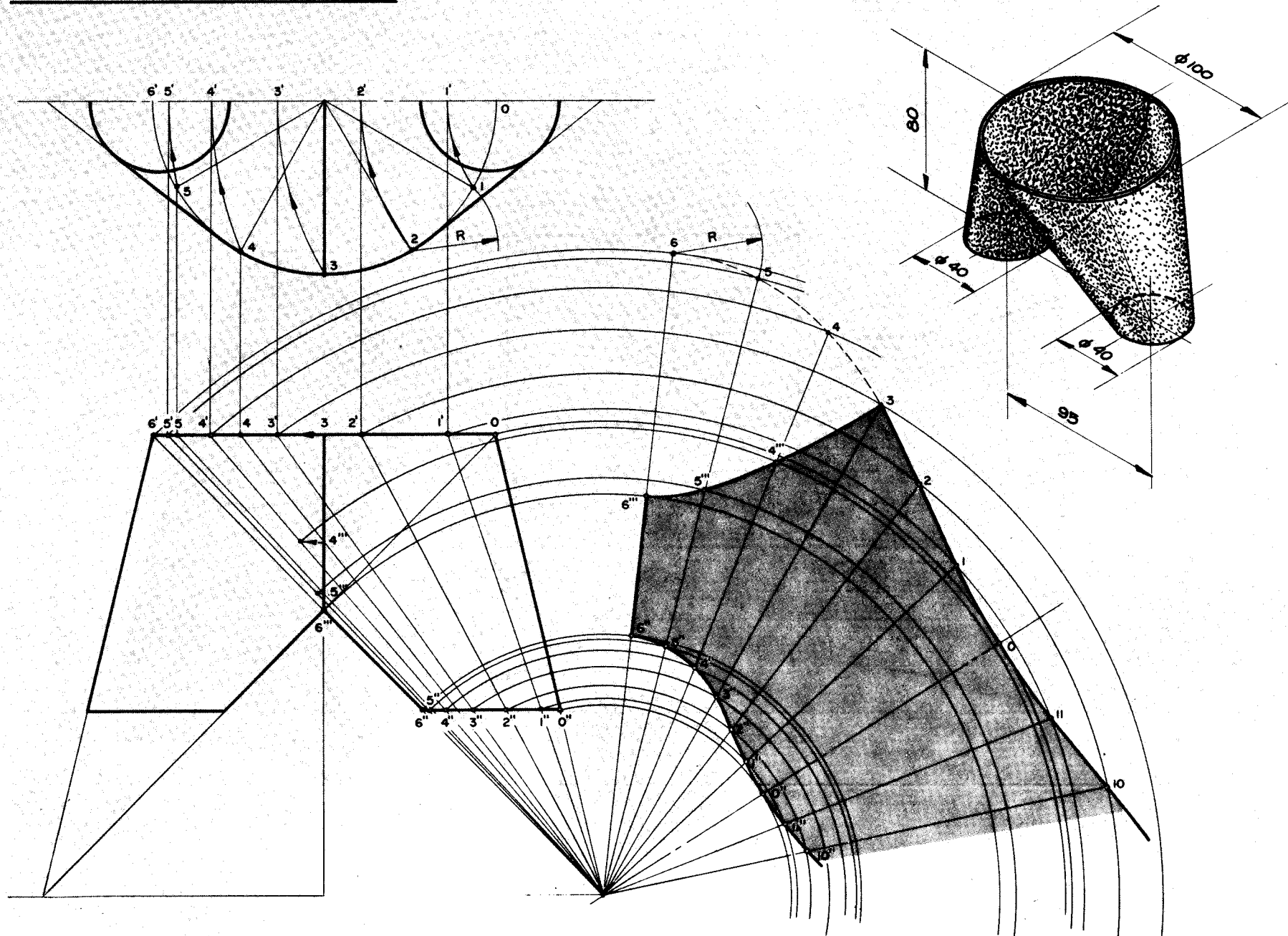

BIFURCAÇÃO ASSIMÉTRICA COM REDUÇÃO

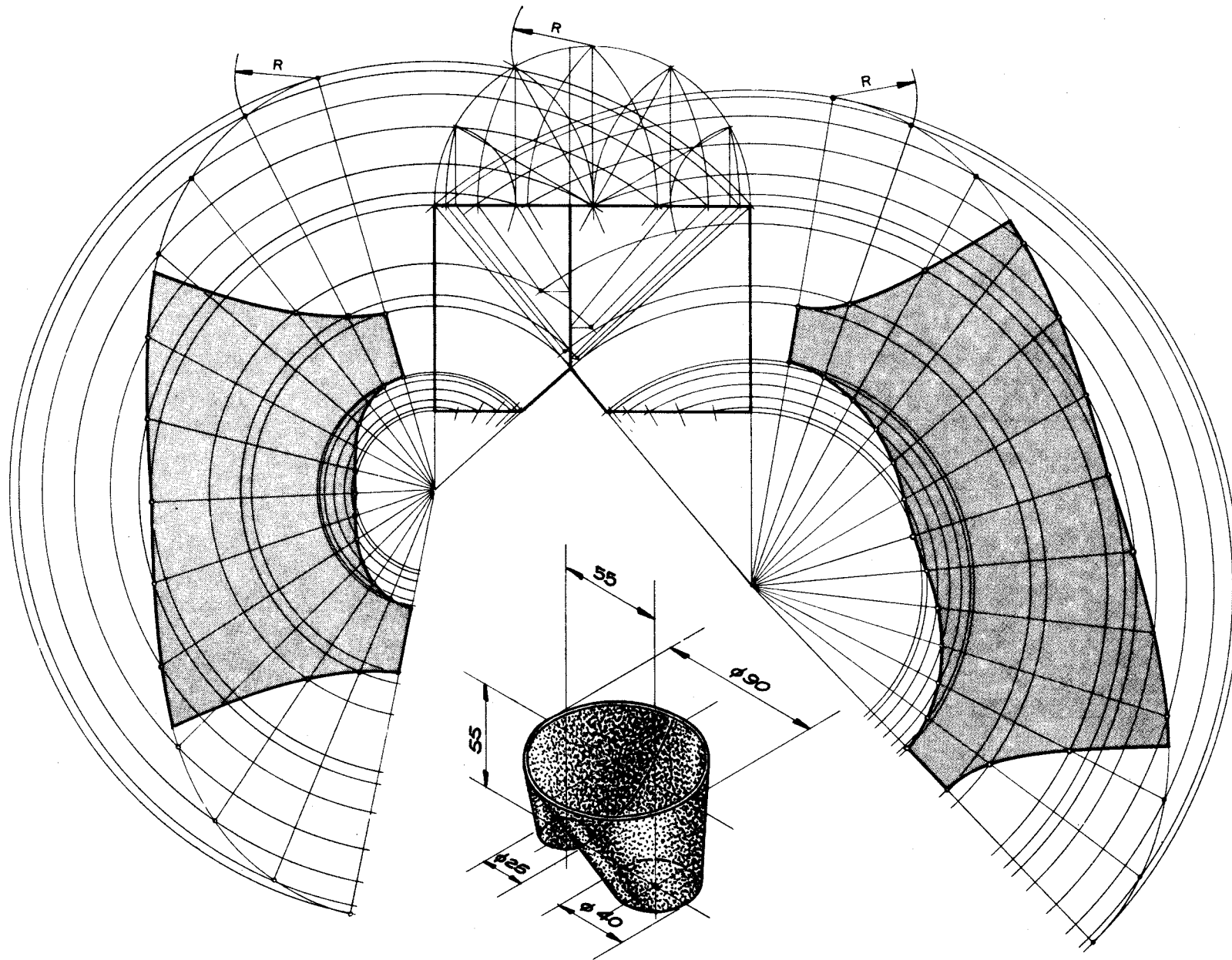

CURVA A 45° DE TRÊS SETORES

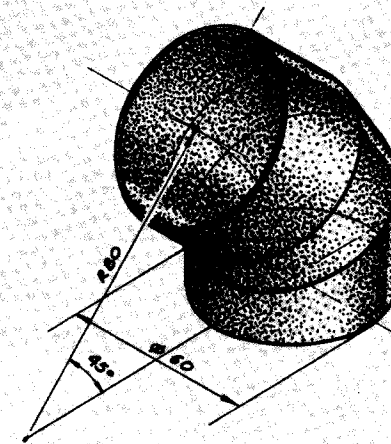
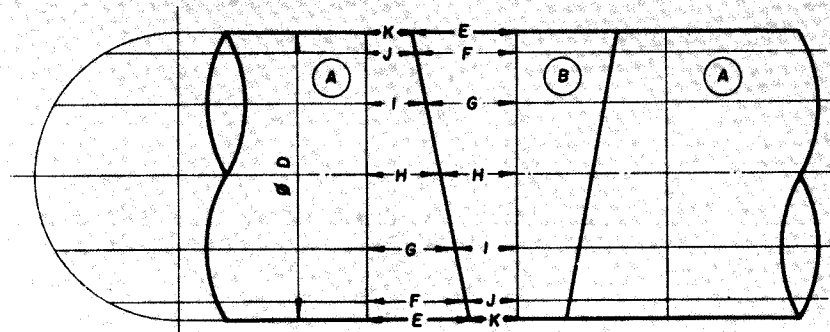
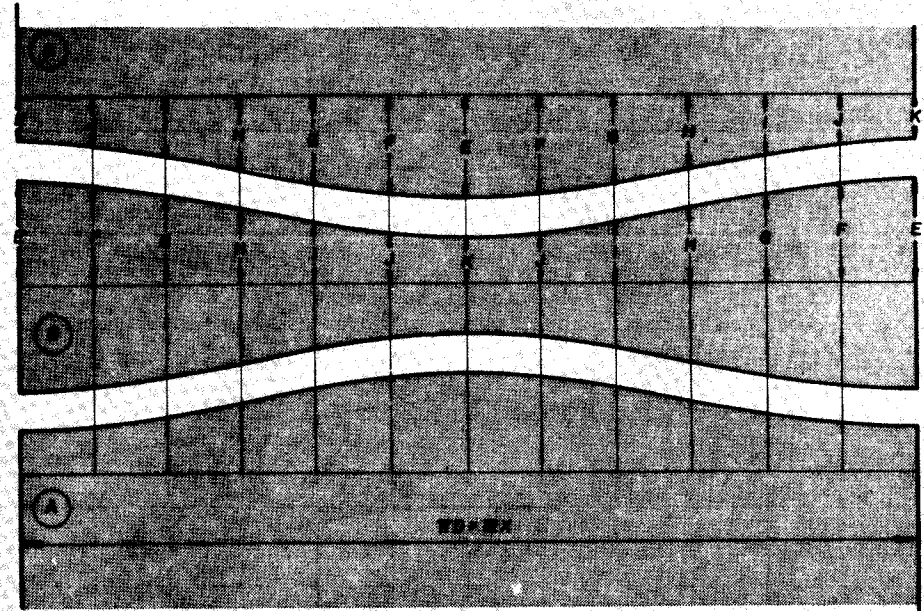
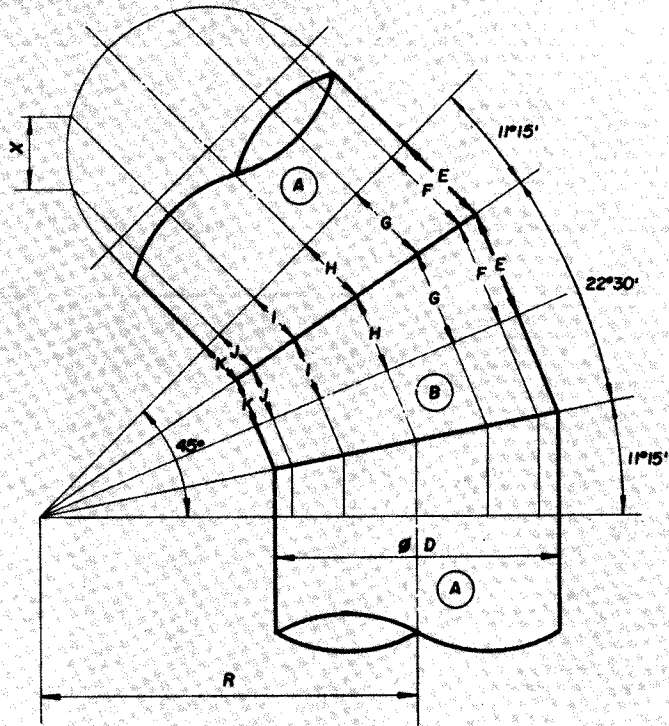

COTOVELO DE 5 SETORES

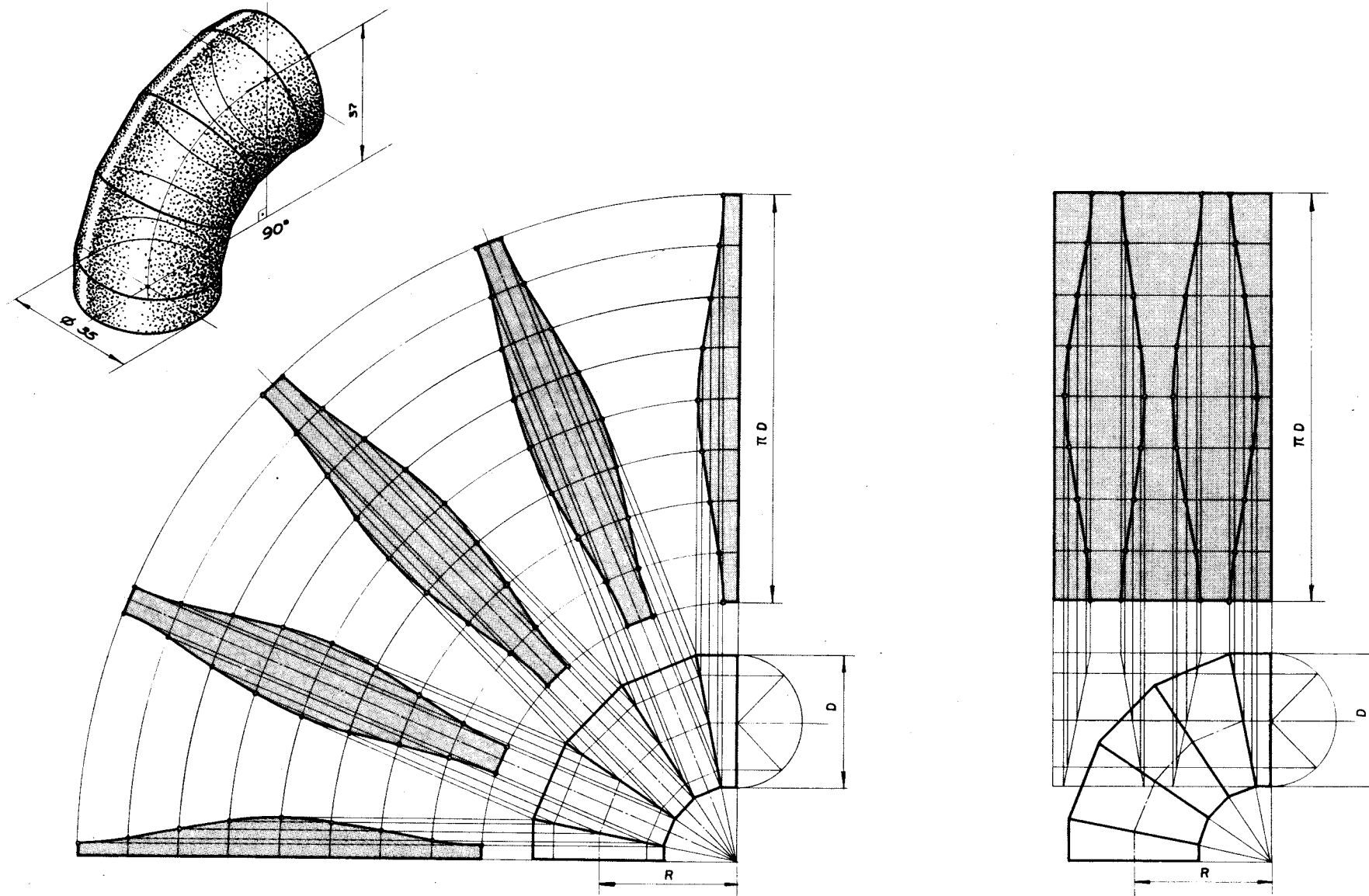

REDUÇÃO CÔNICA EM COTOVELO (5 PARTES)

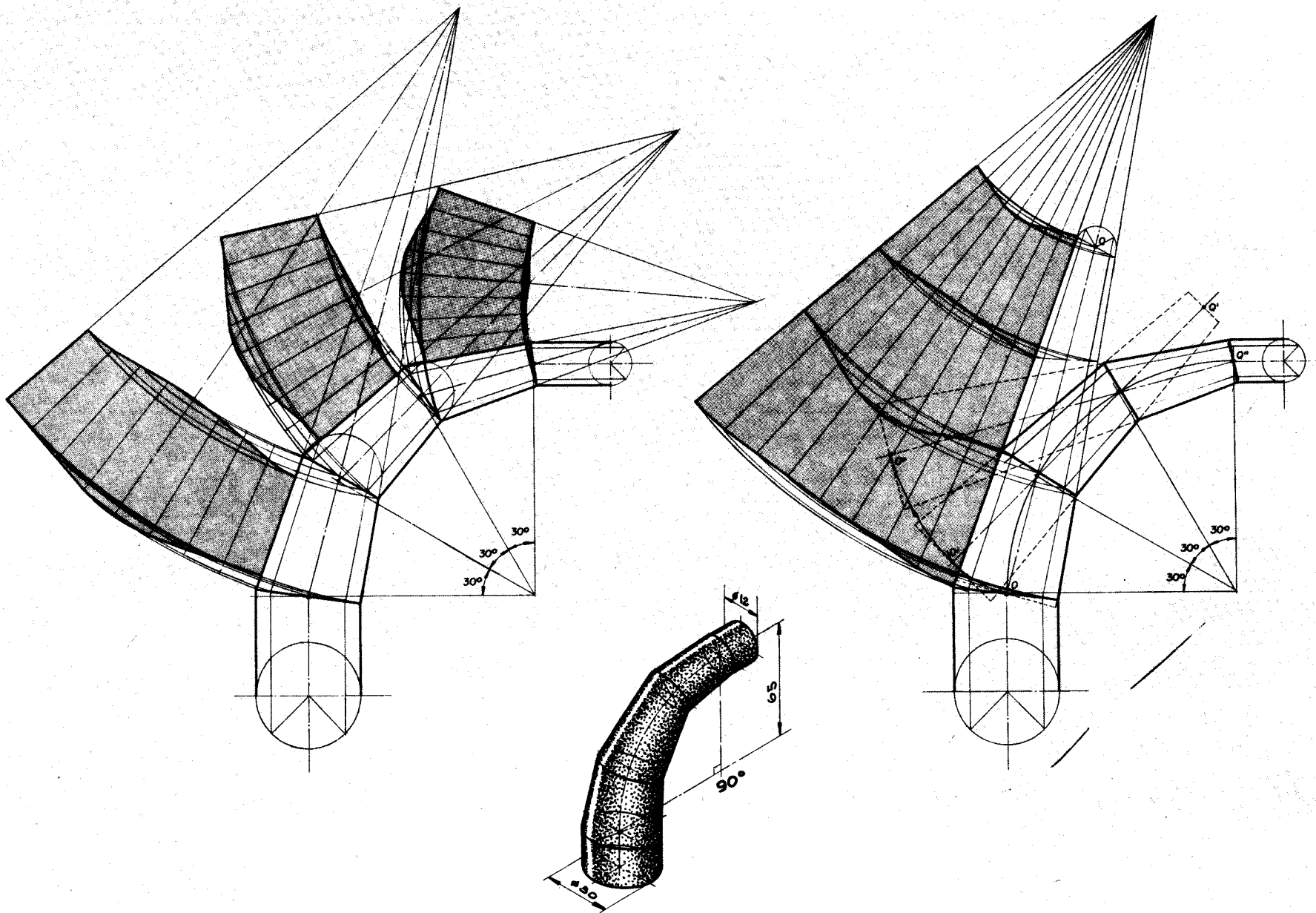

**índice
alfabetico**

A

Acabamento e trabalho superficial	
— indicação	6-28
Alavanca de comando	7-10
Ajustes	6-72
Ar condicionado	7-138
Armazenagem e vaporização de gás liquefeito de petróleo	7-142
Alimentador	7-155

B

Bombinha de óleo	7-30
Bomba de água	7-41
Biela	7-46
Balancim	7-127

C

Construções fundamentais	2-1
Curvas: cônicas	2-7
hélices	2-8
cíclicas	2-9
Conicidade e indicação	6-29
pinos e contrapinos	6-31
chavetas e linguetas	6-33
Correias	
— esticadores	6-55
Correntes	6-56
rodas para corrente	6-57
esticadores de corrente	6-58
Catracas	6-61
Cames	6-62
Chapas, Aremates, Emendas, Desenvolvimentos	8-0
Chave de grifo	7-11
Chave roquete	7-13
Compressor de palheta	7-33
Contra-ponta giratória	7-65
Caixa de direção	7-125

D

Desenhos Técnicos:	
— Classificação	6-2
— Seqüência do traçado	
— de concordâncias	6-3

— de desenho a lápis	6-6
— de desenho a tinta	6-7
— exemplos	6-8
Dispositivos de fixação	6-65
Dispositivos de furar anéis	7-1
Distribuição de óleo de queima	7-143

E

Engrenagens:

Cilíndricas:

— de dentes retos	6-78
— de dentes retos - sistema Pitch	6-80
— de dentes retos e cremalheira	6-82
— de dentes helicoidais	6-86

Cônicas:

— seqüência do traçado	6-88
— a 90°	6-89
— a 90° - Sistema Pich	6-91
— a 75° - Sistema Pich	6-93
— a 120° - Sistema Pich	6-95
— Coroa e rosca sem-fim	6-97

Helicoidais:

— de eixos ortogonais	6-99
— de eixos reversos	6-101
— seqüência do traçado	6-103

Engrenamentos

— a ciclóides	6-106
— a evolventes	6-106

Esticadores

de correia	6-55
de corrente	6-58
Eixo Cadan	6-68
Engraxadeiras	6-70
Extrator	7-7

Cortes e secções	5-7
Rupturas	5-10
Representação simplificada	5-10
Sinais	5-13
Cotas	5-13
Recomendações	5-21
Tipos de reforços	5-21
Alfabeto grego	5-27

O

Odontógrafo de Grant	6-105
--------------------------------	-------

P

Projeções ortogonais:

● Norma europeia	3-1
– exemplos	3-2
– representação	3-5
– peças inclinadas	3-7
– exemplo	3-8
● Norma norte americana	
– métodos	3-11
– comparação	3-12

Perspectiva:

– exata	4-1
– aproximadas	4-2
– de circunferências	4-3
– de peças irregulares	4-6
– escolha	4-7
– posição	4-8
– Seqüência do traçado	4-9
– Cavaleira	4-12
– Isométrica	4-13
– Bimétrica	4-14
– Exemplos	4-15
– Sombreada	4-16
– Croquis	4-19

Porcas e parafusos	6-20
– proporções	6-21
– tipos de porcas	6-22
– arruelas e dispositivos de segurança	6-23
– exemplos de aplicação	6-24
– especiais	6-26
– símbolos	6-27
Pinos e contra-pinos	6-31
Polias	6-53
Polia variável	7-53
Pistão	7-44
Ponte rolante acionada por corrente	7-93
Prensa	
– excêntrica	7-129
– excêntrica de 20 t.	7-130
Plaina limadora	7-132
Pá de hélice de avião	7-133
Planificação	
– prisma reto de secção retangular	8-1
– tronco de prisma reto de secção retangular	8-1
– prisma inclinado de base retangular	8-2
– cilindro reto	8-3
– tronco de cilindro reto	8-3
– pirâmide reta de base quadrada	8-4
– tronco de pirâmide de base quadrada	8-4
– tronco de pirâmide de base hexagonal	8-5
– tronco de pirâmide oblíqua de base retangular	8-6
– cone circular reto	8-7
– tronco de cone circular reto	8-7
– tronco de cone circular reto com base superior oblíqua	8-8
– tronco de cone circular reto com base inferior oblíqua	8-9
– cone circular reto seccionado paralelamente ao eixo	8-10
– cone circular reto seccionado pelo vértice	8-11
– tronco de cone circular oblíquo I	8-12
– tronco de cone circular oblíquo II	8-13

– redução concêntrica de duto redondo para redondo . . .	8-14	● intersecção perpendicular de um cone com um duto re-	
– redução excêntrica de duto redondo para redondo . . .	8-15	dondo	8-40
– transição do duto quadrado para redondo	8-16	● intersecção paralela de um cone reto com um duto redondo	8-41
– transição com redução concêntrica de duto retangular		● intersecção oblíqua de um cone reto com um duto redondo	8-42
para redondo	8-17	● intersecção oblíqua de dois cones	8-43
– transição com redução de duto redondo para quadrado		● bifurcação simétrica	
com desvio paralelo	8-18	– com aumento	8-44
– transição angular a 90° de duto redondo para retangular	8-19	– com redução	8-45
– transição com redução de duto redondo para redondo		● bifurcação assimétrica	
com desvio angular	8-20	– com redução	8-46
– transição com redução de duto redondo para oval com		● curva de 45° de três setores	8-47
desvio paralelo	8-21	● cotovelo de 5 setores	8-48
– fechamento esférico de duto redondo	8-22	● redução cônica em cotovelo	8-49
– esfera	8-23		
– coifa	8-24	Q	
– recipiente de base elíptica	8-25		
– banheira	8-26	R	
– calha	8-27	Rebites	6-37
– desvio paralelo de dutos retangulares	8-28	– Aplicação	6-38
– desvio angular	8-29	– Especiais	6-39
– moldura	8-30	– Rebitagem de caldeiraria	6-40
– intersecção perpendicular de dutos quadrados	8-31	– Estruturas rebitadas	6-41
● intersecção:		– Símbolos	6-42
– perpendicular de dutos redondos	8-31	Rolamentos:	
– com diâmetros iguais	8-32	– Tipos	6-74
– com diâmetros diferentes	8-33	– Fixação e vedação	6-76
– ortogonal de dutos redondos	8-34	– Aplicação	6-77
– oblíqua de dutos redondos		Rodízio giratório	7-62
– com diâmetros diferentes	8-35	Roscas:	
– com diâmetros iguais	8-36	– Tipos	6-15
● bifurcação simétrica de dutos redondos	8-37	– Inclinação	6-16
● intersecção de três dutos redondos		– Traçado	6-17
– com diâmetros iguais	8-38	– Seqüência do traçado	6-18
● redução com bifurcação simétrica de dutos redondos	8-39	– Aplicação	6-19

Redutor:

— do transportador helicoidal	7-110
— de velocidade	7-119
— de rosca sem-fim	7-122
Registro de gaveta	7-134
Refrigeração	7-139

S

Soldas:

— Símbolos	6-43
— a arco elétrico ou a gás	6-45
— Normas - Especificações dos Cordões de solda.	6-46
— exemplos	6-48
— com resistência elétrica	6-49
— exemplos	6-50
— comparação	6-51
— exemplos de aplicação	6-52
Sarrilho para 250 kg	7-79

T

Trabalho superficial	
— indicação	6-28
Tolerâncias e ajustes	6-72
Torninho mecânico	7-2
Torninho paralelo	7-3
Tesourão de bancada	7-24
Tuchos para válvula	7-52
Transportador aéreo	7-86
Trole acionado por corrente	7-88
Trole elétrico	7-92
Talha manual para 1500 kg	7-98
Transportador de correia	7-101
— de caneca	7-103
— helicoidal	7-107

U

Uniões:

— efeito de cunha	6-34
— eixos ranhurados	6-35
— juntas	6-66

V

Volantes e manivelas	6-64
Válvula de segurança	7-29
Variador de velocidade	7-55
— tipos	7-58