

Moldes Sólidos 2 cavidades

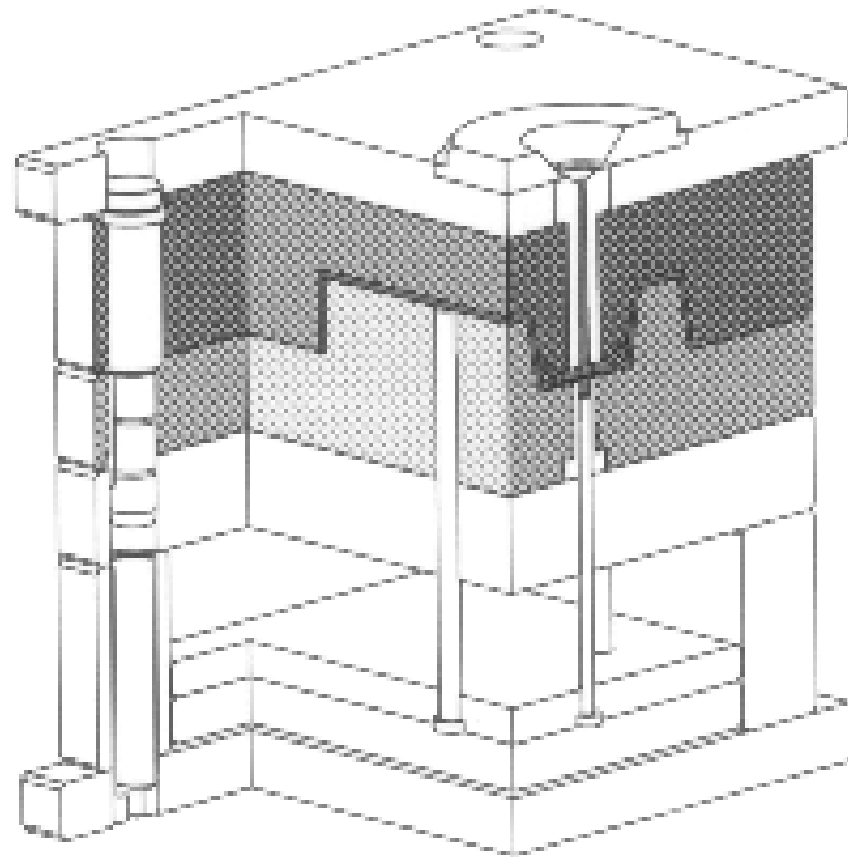

Molde Sólido Multicavidades

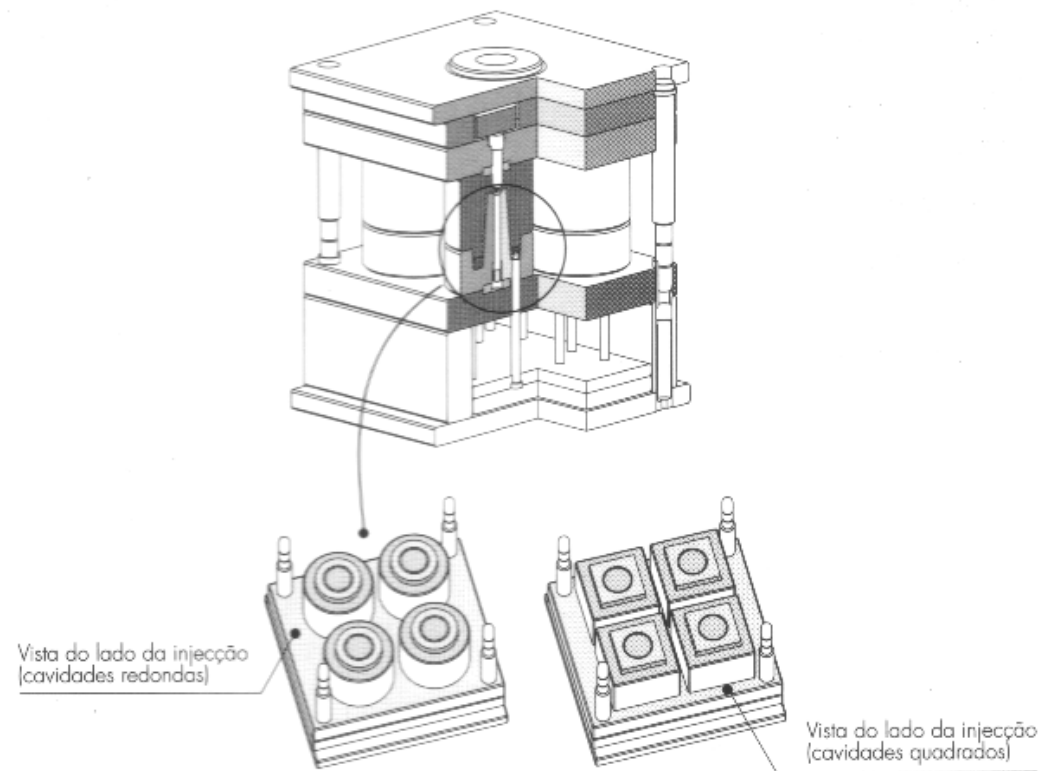

Moldes Estruturados (em caixa e aro)

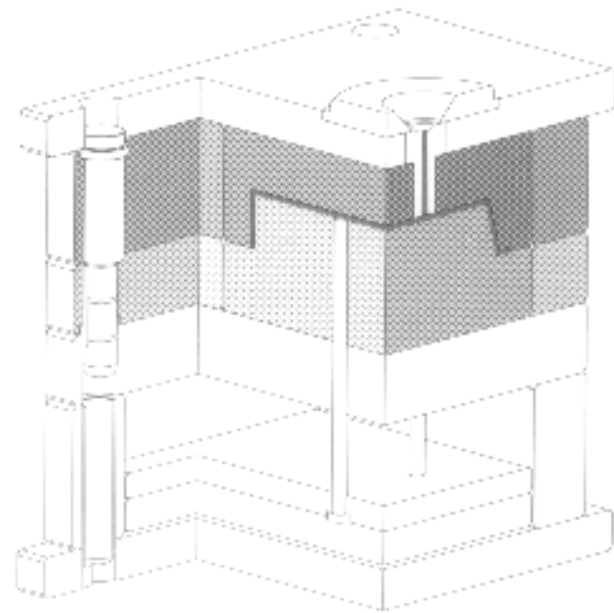
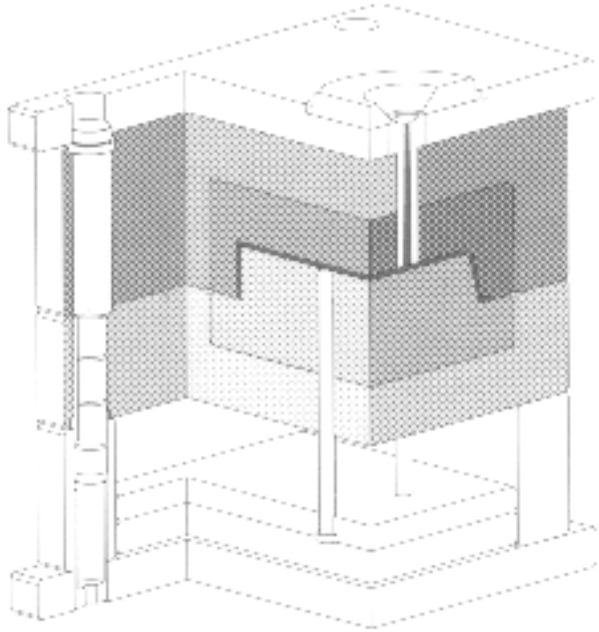

Moldes Estruturados com cavidades cilíndricas

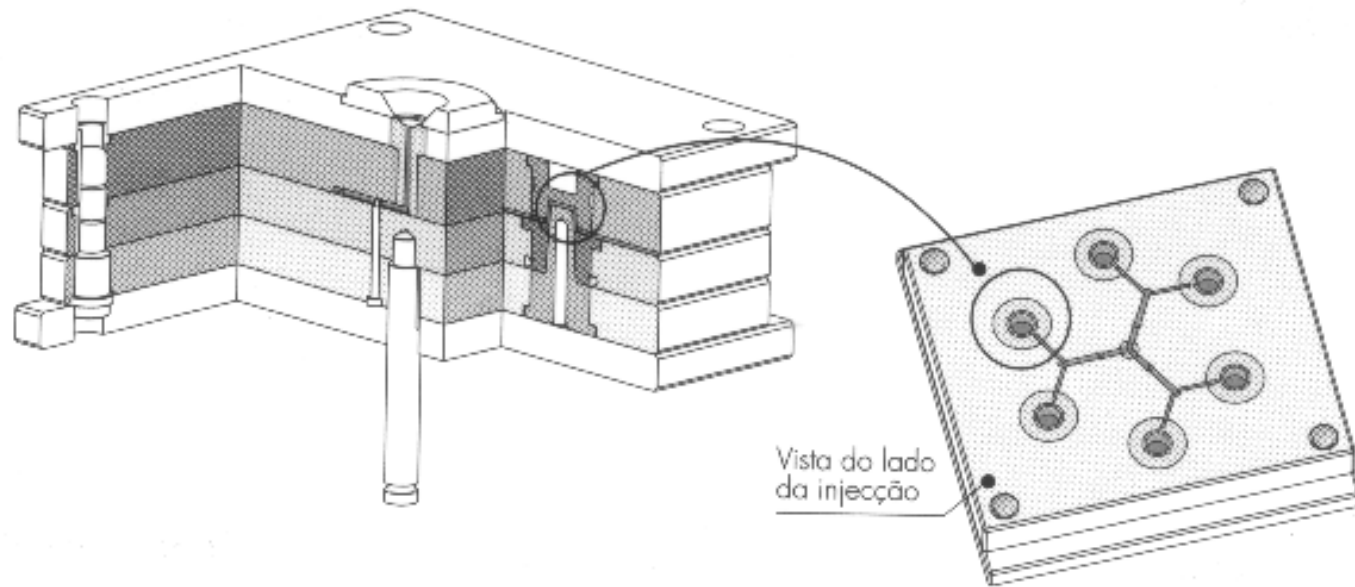

Molde Estruturado de 3 placas com canais frios com bico da máquina dentro do molde

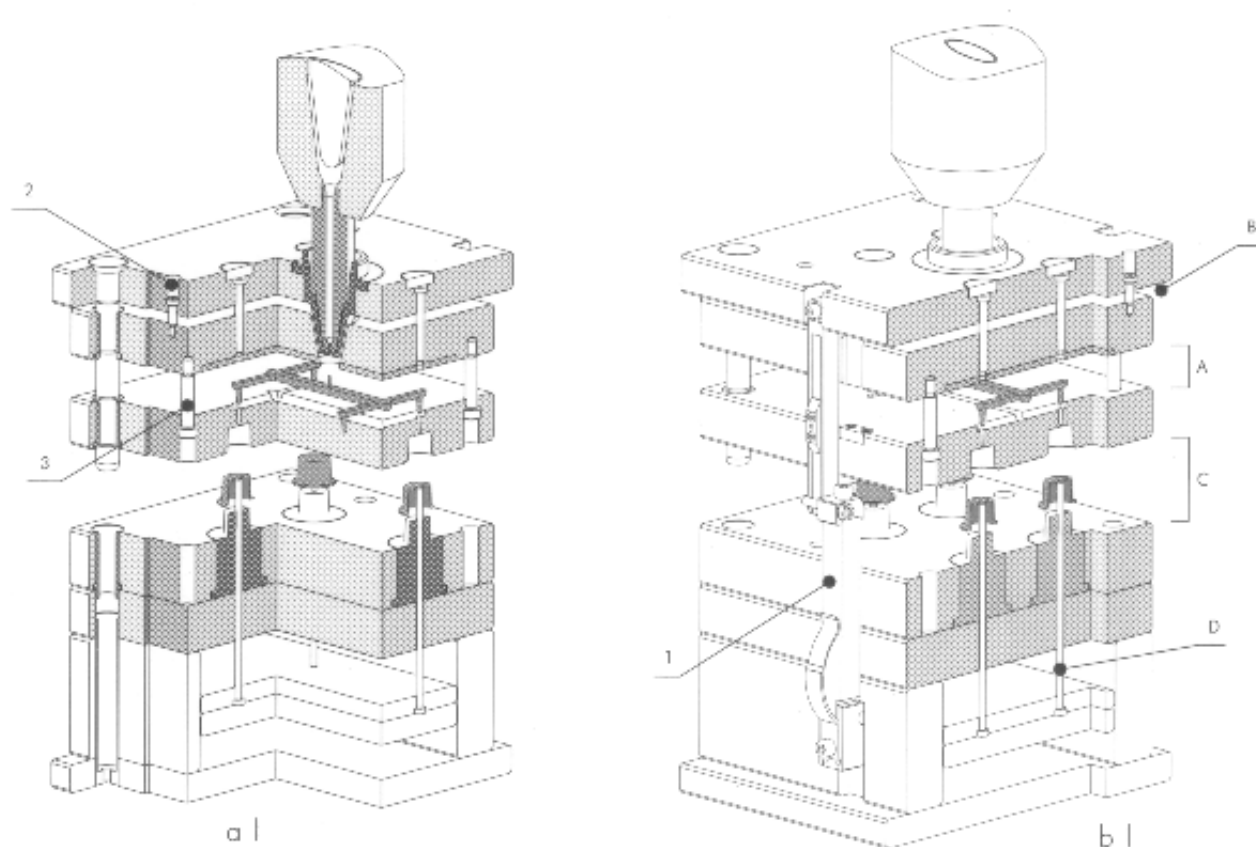

Molde de três placas com canais frios com bicos quentes

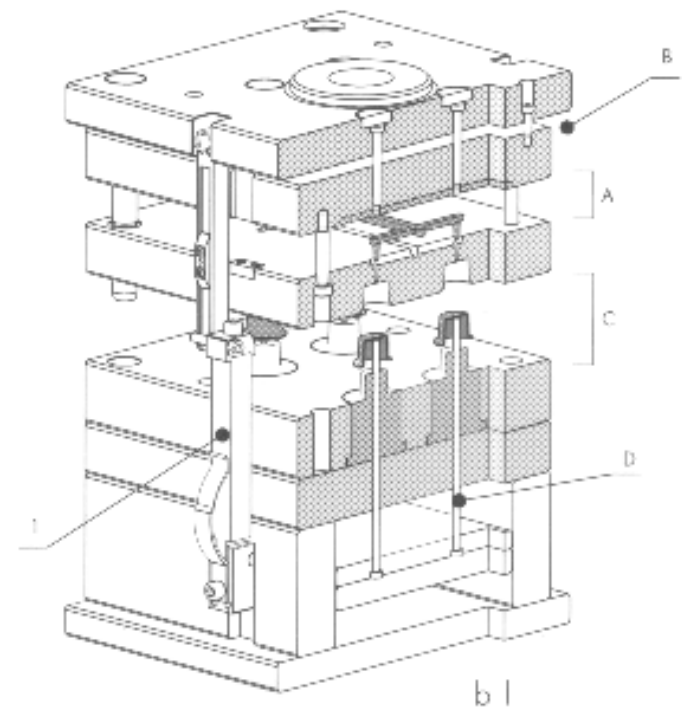
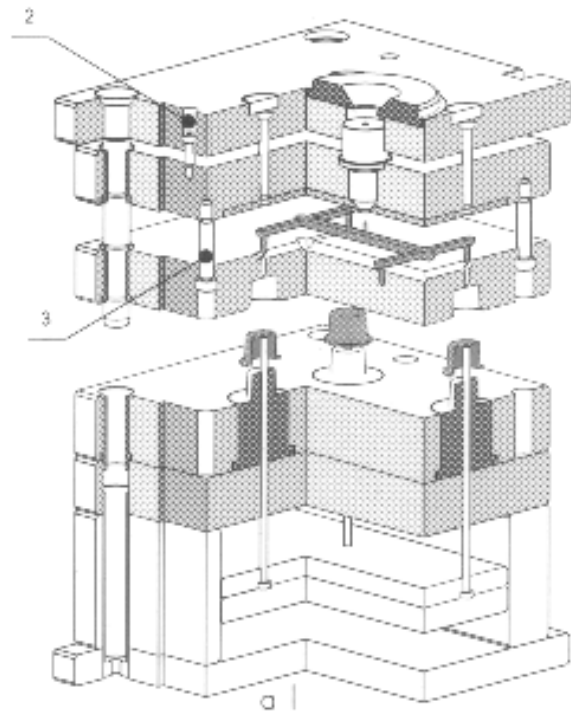

Molde mini canal de injeção

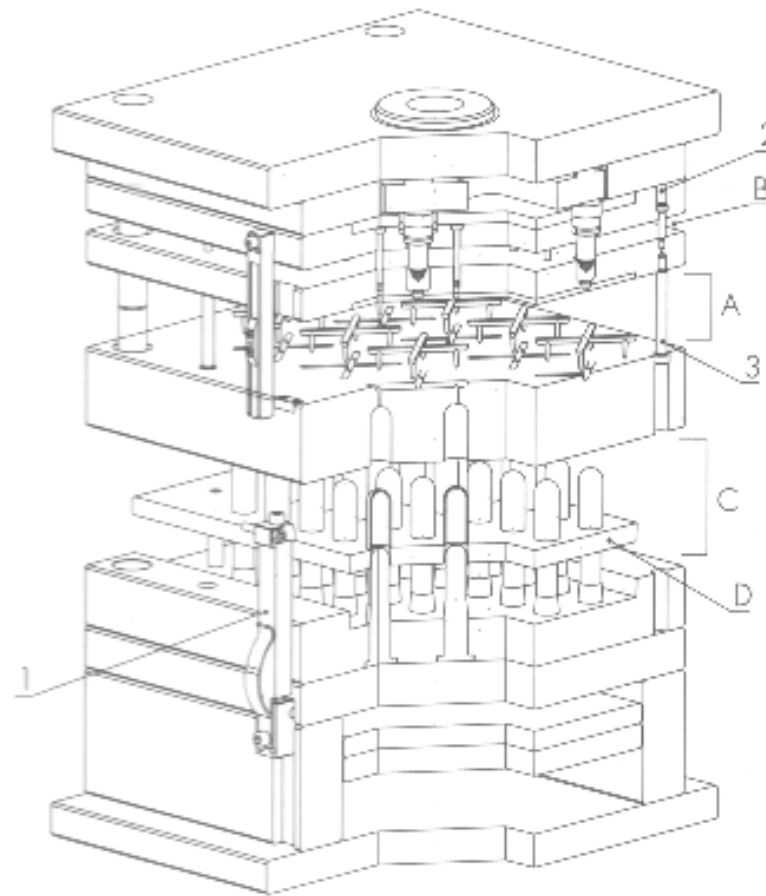

Molde Família

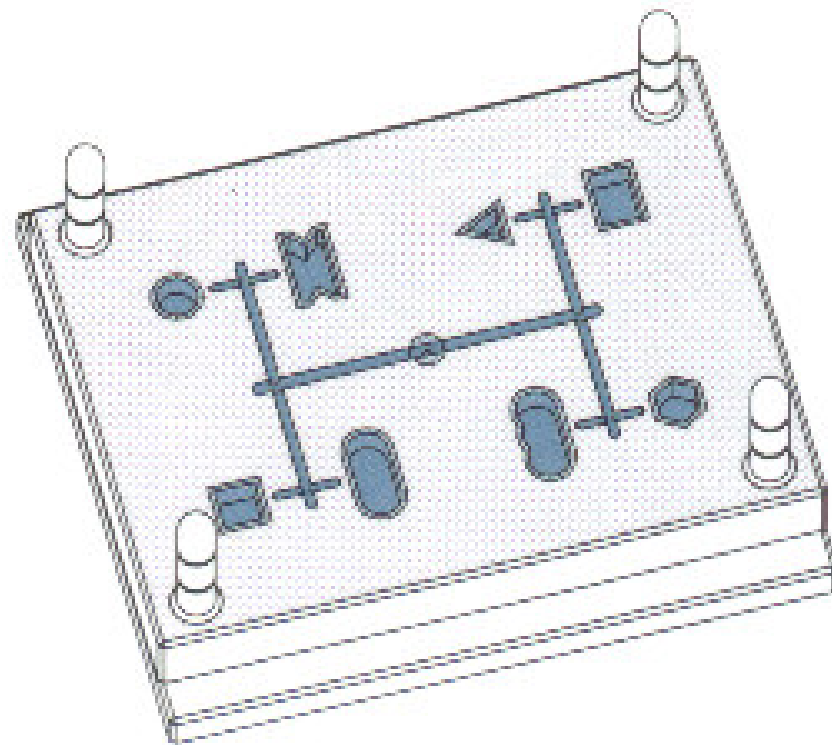

Molde com cremalheira

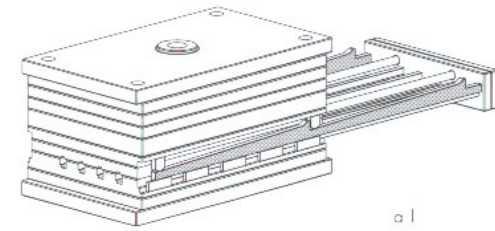

a)

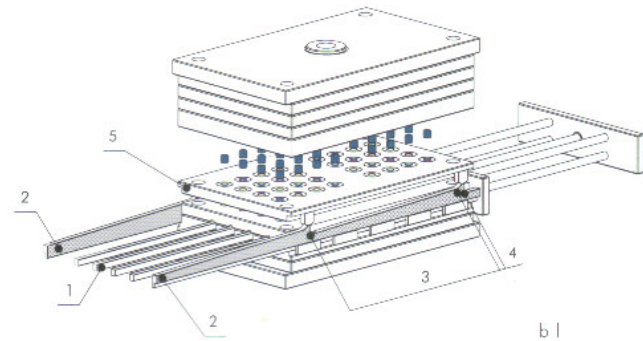

b)

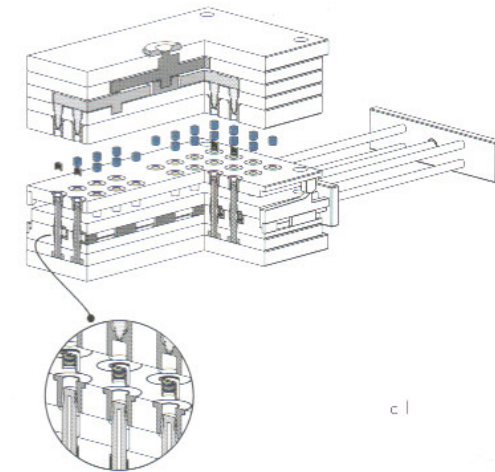

c)

Molde em andares (Sandwich)

